

# 2240 Tractor (S/N-349999L)



JOHN DEERE

## TECHNICAL MANUAL 2240 Tractor (S/N-349999L)

TM4301 (01Aug75) English

**John Deere Tractor Works**  
**TM4301 (01Aug75)**

LITHO IN U.S.A.  
ENGLISH



# Tractor 2240

Technical Manual  
TM-4301 (Aug-75)

*All information, illustrations and specifications contained in this technical manual are based on the latest information available at the time of publication. The right is reserved to make changes at any time without notice.*

Copyright© 1975  
DEERE & COMPANY  
Moline, Illinois  
All rights reserved

*Litho in U.S.A.*

**GENERAL 10**

**ENGINE 20**

**FUEL SYSTEM 30**

**ELECTRICAL SYSTEM 40**

**POWER TRAIN 50**

**STEERING AND BRAKES 60**

**HYDRAULIC SYSTEM 70**

**MISCELLANEOUS 80**

## INTRODUCTION

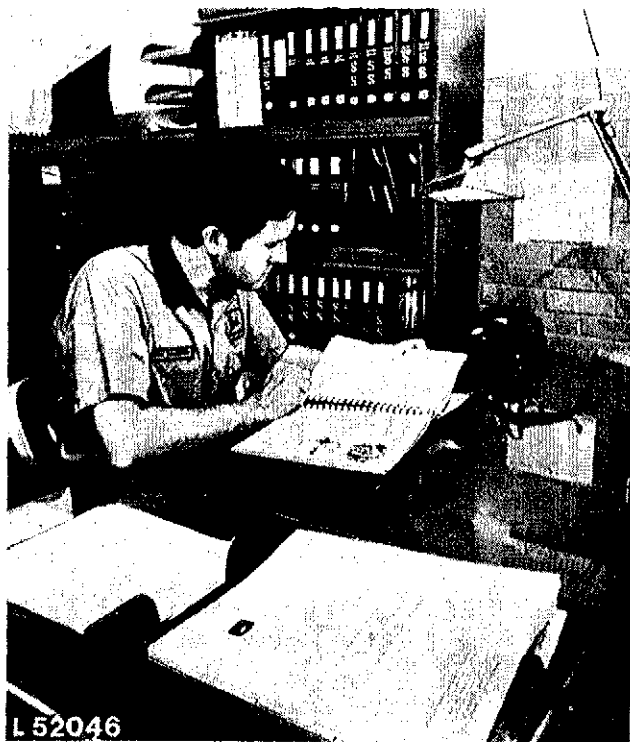

*Use FOS Manuals for Reference*

This technical manual is part of a twin concept of service:

- FOS Manuals — for reference
- Technical Manuals — for actual service

The two kinds of manuals work as a team to give you both the general background and technical details of shop service.

*Fundamentals of Service (FOS) Manuals* cover basic theory of operation, fundamentals of trouble shooting, general maintenance, and basic types of failures and their causes. FOS Manuals are for training new personnel and for reference by the experienced technician.

*Technical Manuals* are concise service guides for a specific machine. Technical Manuals are on-the-job guides containing only the vital information needed by an experienced technician.



When any serviceman should refer to a FOS Manual for more information, a FOS symbol like the one at the left is used in the TM to identify the reference.



*Use Technical Manuals for Actual Service*

Some features of this technical manual:

- Table of contents at front of whole Manual
- Contents at front of each Section
- Exploded views showing parts relationship
- Photos showing service techniques
- Specifications at end of each Group
- Special tools at end of each Group

This technical manual was planned and written for you — an experienced technician. Keep it in a permanent binder in the shop where it is handy. Refer to it whenever in doubt about correct service procedures or specifications.

Using the technical manual as a guide will reduce error and costly delay. It will also assure you the best in finished service work.



This safety alert symbol indicates important safety messages in this manual. When you see this symbol, be alert to the possibility of personal injury and carefully read the message that follows.

# Section 10 GENERAL

## CONTENTS OF THIS SECTION

### GROUP 5 — SPECIFICATIONS

	Page
Serial numbers . . . . .	5-2
Model numbers . . . . .	5-2
Engine . . . . .	5-2
Engine clutch . . . . .	5-2
Electrical system . . . . .	5-2
Transmission . . . . .	5-3
Hi-Lo shift unit . . . . .	5-3
Differential and final drives . . . . .	5-3
Differential lock . . . . .	5-3
PTO . . . . .	5-3
Hydraulic system . . . . .	5-3
Power steering . . . . .	5-3
Manual steering . . . . .	5-3
Hydraulic brakes . . . . .	5-3
Capacities . . . . .	5-3
Travel speeds . . . . .	5-3
Front and rear wheels . . . . .	5-3
Dimensions and weights . . . . .	5-3

### GROUP 10 — PREDELIVERY, DELIVERY AND AFTER-SALES INSPEC- TIONS

Predelivery inspection . . . . .	10-1
Delivery inspection . . . . .	10-4
After-sales inspection . . . . .	10-4

### GROUP 15 — LUBRICATION AND PERIODIC SERVICE

	Page
Lubrication and periodic service . . . . .	15-1

### GROUP 20 — ENGINE AND TRACTOR TUNE-UP

General information . . . . .	20-1
Preliminary engine testing . . . . .	20-1
Engine tune-up . . . . .	20-2
Checking engine performance . . . . .	20-3
Tractor tune up . . . . .	20-3
Standard torques . . . . .	20-5

### GROUP 25 — TRACTOR SEPARATION

Separating between engine and tractor front end . . . . .	25-1
Removing and installing engine . . . . .	25-3
Removal and installation of clutch housing . . . . .	25-5
Removal and installation of final drives . . . . .	25-7
Removal and installation of rockshaft . . . . .	25-8
Torques for hardware . . . . .	25-9
Special tools . . . . .	25-10

# Group 5 SPECIFICATIONS

## SERIAL NUMBERS

The engine serial number is stamped into the name plate at the lower right of the cylinder block.

*NOTE: If ordering engine parts, indicate all digits of the serial number on the name plate.*

The name plate showing the tractor serial number is located on the right-hand side of the front support.

*NOTE: If ordering tractor parts, (excluding engine parts), indicate all digits of the serial number on the name plate.*

## MODEL NUMBERS

The injection pump, injection nozzles, the alternator, starting motor and the hydraulic pump have model numbers to facilitate identification of different makes of a given unit.

## SPECIFICATIONS

### ENGINE

Number of cylinders	3
Cylinder liner bore	106.5 mm (4.19 in.)
Stroke	110 mm (4.33 in.)
Displacement	2940 cm <sup>3</sup> (179 cu.in.)
Compression ratio	
(-271533CD)	16.2 : 1
(271534CD-)	16.8 : 1
Maximum torque at	
1300 rpm	188 Nm (138 ft.lbs.)
Firing order	1 - 2 - 3
Valve clearance (engine hot or cold)	
Intake valve	0.35 mm (0.014 in.)
Exhaust valve	0.45 mm (0.018 in.)

Fast idle	2650 rpm
Slow idle	650 rpm
Working speed range	1500 to 2500 rpm
PTO power*	37 kW (50 HP)
(at 2500 rpm engine speed and 650 rpm powershaft speed)	

### ENGINE CLUTCH

Dual-stage dry disk clutch, foot-operated (on tractors with continuous running PTO)

Single-stage dry disk clutch with torsion damper (isolator), foot-operated (on tractors with independent PTO)

### ELECTRICAL SYSTEM

Batteries	2 x 12 volts, 55 ampere-hours
or	1 x 12 volts, 55 ampere-hours
Starting motor	12 volts, 3 kW (4 HP)
Alternator	14 volts, 28 amps.
Battery terminal grounded	negative

\* With the engine run in (more than 100 hours of operation) and having reached operating temperature (engine and transmission); measured by means of a dynamometer. Permissible variation  $\pm 5\%$ .

TRANSMISSION

Type . . . . . Collar shift

Gear selections . . . . . 8 forward and 4 reverse

Shifting . . . . . 4 speeds each in high, low, and reverse ranges. Park lock included.

HI-LO SHIFT UNIT

Hydraulically controlled reduction gear which can be shifted under load, with "wet" multiple disk clutch and "wet" multiple disk brake. Allows reduction of the individual gear speeds by 21 %.

DIFFERENTIAL AND FINAL DRIVES

Planetary reduction gear and differential with spiral bevel gears.

DIFFERENTIAL LOCK

Hand or foot operated; spring-loaded out of engagement.

PTO

Type . . . . . Rear 540 rpm continuous-running or independent

Power Shaft Speeds

Engine Speed in rpm	PTO shaft speed in rpm
650	169
2067	538
2075	540
2500	650
2650	689

HYDRAULIC SYSTEM

Closed center, constant pressure system; also includes rockshaft, power steering and selective control valves.

Stand by oil pressure . . . . . 15 304 to 15 718 kPa  
 (153 to 157 bar)  
 (2220 to 2280 psi)

Pump . . . . . 8-piston pump driven by the engine

POWER STEERING

The steering system is a "closed center" type incorporated by the hydraulic system and supplied with oil by the hydraulic pump. It is connected to the front wheels by means of a steering linkage.

MANUAL STEERING

The manual steering is a recirculating ball bearing, worm and nut type. A number of steel balls between ball nut and steering wheel shaft provide for positive engagement of steering wheel and steering linkage.

HYDRAULIC BRAKES

The disk brakes run in an oil bath and are hydraulically controlled.

CAPACITIES

	Ltr.	US.gals.
Fuel tank . . . . .	62.5	16.5
Cooling system . . . . .	10.0	2.6
Engine crankcase incl. filter . . . . .	7.0	1.8
Transmission-hydraulic system		
Dry system . . . . .	36.0	9.5
At service intervals . . . . .	28.0	7.4
Belt pulley . . . . .	1	0.3

TRAVEL SPEEDS

See Operator's Manual

FRONT AND REAR WHEELS

For tire sizes, treads, inflation pressure and weights see Operator's Manual.

DIMENSIONS AND WEIGHTS

See Operator's Manual.

## Group 25

# TRACTOR SEPARATION

### SEPARATING BETWEEN ENGINE AND TRACTOR FRONT END

#### REMOVAL

For safety disconnect ground straps from batteries.

Remove front end weights (if equipped).

Remove radiator cap and fuel tank cap. Remove radiator side grille screens and hood. Install radiator and fuel tank caps. Remove tool box and side frames.

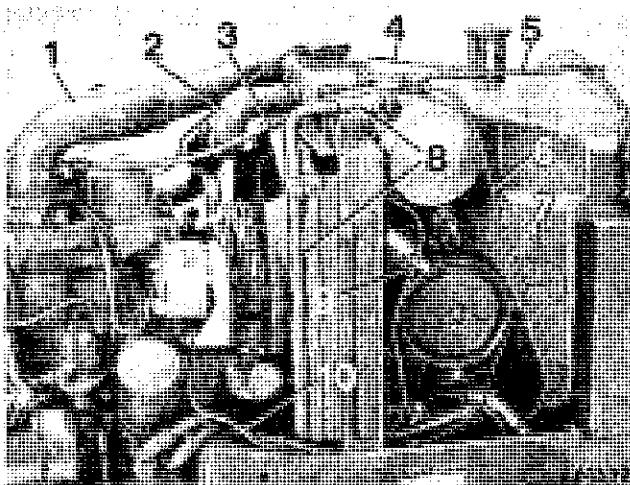

Fig. 1 — Separating between Tractor Front End and Engine

- |                           |   |
|---------------------------|---|
| 1 Air intake pipe         | 7 Cable of fuel gauge sending unit                |
| 2 Upper water hose        | 8 Return oil line                                 |
| 3 Leak-off and bleed line | 9 Cable of air cleaner restriction warning switch |
| 4 Fuel return line        | 10 Fuel inlet line, tank to fuel transfer pump    |
| 5 Support rod             |   |
| 6 Leak-off and bleed line |   |

Disconnect air intake pipe (see 1, fig. 1) at engine intake manifold and at air cleaner.

Disconnect leak-off and bleed lines 3 and 6 at hydraulic oil reservoir.

Remove support rod 5 at top of radiator. Disconnect fuel return line 4 at fuel tank.

Disconnect cable 9 at air cleaner restriction warning switch and disconnect cable 7 at fuel gauge sending unit.

Drain coolant and disconnect upper and lower water hoses at radiator.

*Only on tractors equipped with oil cooler:* Remove hose elbow between hydraulic oil reservoir and oil cooler at oil cooler end. Disconnect return oil line at bottom of oil cooler.

*Only on tractors without oil cooler:* Disconnect return oil line 8 at top and bottom hose and remove.

*NOTE: Plug lines and openings immediately with plugs or caps to prevent loss of oil and entering of dirt into the system.*

Remove screws securing fan shroud to radiator and slide over fan to the rear.

Remove screws securing radiator to front axle support and lift out radiator to the left of tractor.

Close fuel shut-off valve at bottom of fuel tank.

Disconnect fuel inlet line 10 at fuel tank and fuel transfer pump. Remove transfer pump and fuel inlet line.

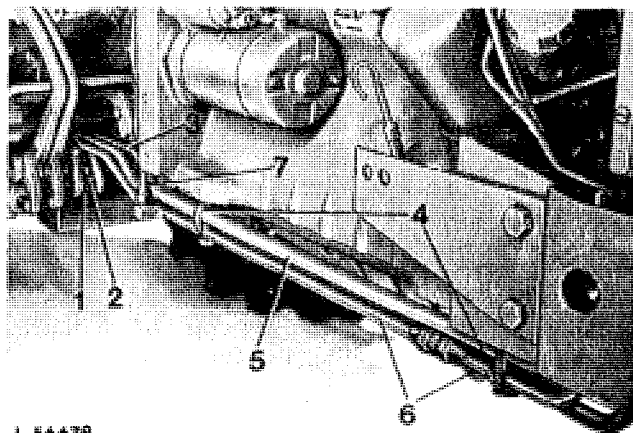

Fig. 2 — Disconnecting Hydraulic Lines

- 1 Retainer
- 2 Cap screw
- 3 Return line to transmission case
- 4 Clamps
- 5 Hydraulic pump inlet line
- 6 Hydraulic pump pressure line
- 7 Power steering pressure line

Remove both clamps (see 4, fig. 2).

Unscrew cap screw 2 and remove retainer 1 which supports the hydraulic pump inlet line 5 and return line 3 of oil cooler or oil reservoir (if not equipped with oil cooler).

*On tractors not equipped with Hi-Lo transmission and independent PTO:* Take care that the check valve installed in hydraulic pump inlet line 5 is not lost when the inlet line is removed.

Remove power steering pressure line 7 (if equipped).

Disconnect pressure line 6 at union.

Disconnect drag link at bell crank.

Remove clamping screw of hydraulic pump drive shaft.

Place a support stand under clutch housing.

Insert wooden blocks between front axle and front support to prevent the latter from tipping sideways.

Attach JDG-9 support stand to front support.

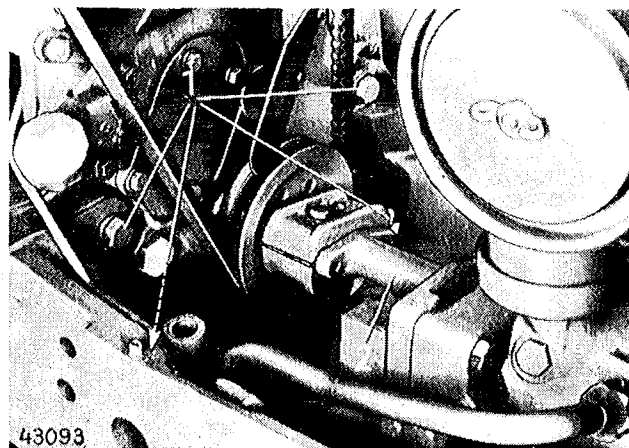

Fig. 3 — Attaching Points of Tractor Front End

- 1 Attaching screws of front axle support
- 2 Hydraulic pump drive shaft

Remove cap screws (see 1, fig. 3) of front support and both cap screws located at the rear of front support and separate front end from engine. Take measures to prevent front of tractor from tipping forwards (drain fuel tank if it contains too much fuel or support front end of tractor).

#### INSTALLATION

Make sure woodruff key is installed in shaft of hydraulic pump.

Move tractor front end toward engine.

Engage pump shaft in hydraulic pump drive shaft and at the same time slide oil return line and hydraulic pump inlet line into clutch housing bores (making sure both seal rings have been installed) and tighten both lines (see fig. 2). Tighten cap screw (see 2, fig. 2) of retainer 1 to the specified torque.

**IMPORTANT:** On tractors not equipped with Hi-Lo unit and independent PTO: Ensure check valve is inserted in hydraulic pump inlet line before it is installed.

Attach front end of tractor to engine. Tighten cap screws to specified torque. Tighten hydraulic pump drive shaft clamping screw to specified torque.

*NOTE:* Do not tighten clamping screw of hydraulic pump drive shaft until tractor front end is secured to engine.

Install fuel transfer pump and connect fuel lines.

Remove JDG-9 support stand.



Make sure transfer pump inlet line is behind and below fuel pressure line.

Open fuel tank shut-off valve.

Connect cable to fuel gauge sending unit and to air cleaner restriction warning switch.

Lift and slide radiator into location from the left side of tractor. Slide fan shroud forward over radiator and secure with screws. Secure radiator to front axle support. Install upper and lower water hoses.

*Only on tractors equipped with oil cooler:* Connect hose elbow between hydraulic oil reservoir and oil cooler at top of oil cooler and return line at bottom of oil cooler.

*Only on tractors not equipped with oil cooler:* Connect oil line to oil reservoir and tighten both hose clamps.

Connect leak-off and bleed lines to hydraulic reservoir.

Connect hydraulic pump pressure line and install line spacers and clamps (see fig. 2).

Connect air intake pipe at manifold and air cleaner.

Attach drag link to bell crank and tighten slotted nut to specified torque.

Install hood and radiator side grille screens.

Fill radiator with clear, soft water, adding an anti-freeze and rust inhibitor mixture (see operator's manual).

Connect battery ground straps.

**IMPORTANT:** Always connect ground straps to negative(-) pole of batteries.

Start engine and check fuel lines, hydraulic lines and water hoses for leaks.

## REMOVING AND INSTALLING ENGINE

*NOTE: For most engine service operations the engine need not be removed. However, if the crankshaft has to be removed or in case of major overhaul, remove engine.*

### REMOVAL

For safety disconnect ground straps from batteries.

Separate tractor front end from engine, as explained previously.

Disconnect cables between alternator and regulator by removing three-terminal plug at alternator. Disconnect red cable at terminal B+ of alternator.

Disconnect all cables 4 at starting motor (see fig. 4). Disconnect oil pressure warning switch cable 3.

Disconnect flexible shaft 2 of speed-hour meter at clutch housing and camshaft. If necessary, replace gasket.

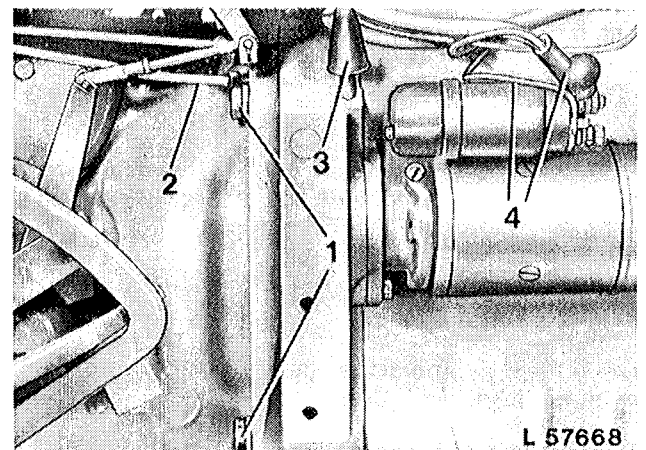

Fig. 4 — Separating between Engine and Clutch Housing, R.H. Side

- 1 Engine attaching points
- 2 Flexible shaft of speed-hour meter
- 3 Oil pressure warning switch
- 4 Starter cables

*On tractors equipped with starting fluid aid:*  
Disconnect starting fluid line at intake manifold.

Remove bleed line of hydraulic oil reservoir from clamp at rocker arm cover.

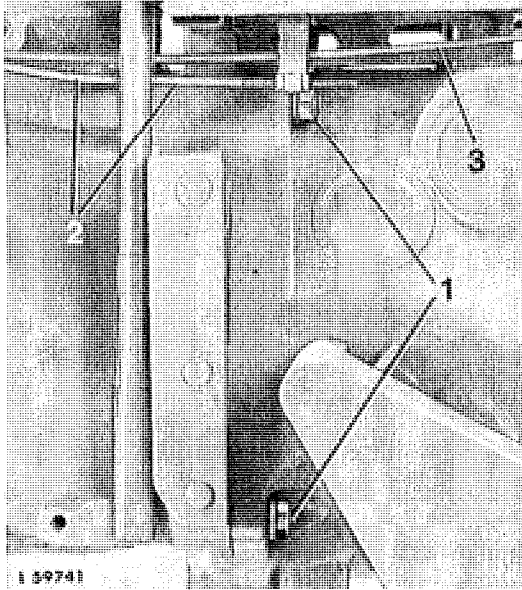

Fig. 5 — Separating between Engine and Clutch Housing, L. H. Side

- 1 Engine attaching points
- 2 Speed control rod
- 3 Shut-off cable

Disconnect speed control rod 2 (fig. 5) and shut-off cable 3 at fuel injection pump.

*On tractors with underneath muffler:* Remove muffler.

Disconnect temperature gauge sensing bulb from cylinder head.

Remove left dash panel as well as both batteries.

Remove cap screws attaching cowl to flywheel housing.

Attach JD 244-1 and 244-2 engine lifting eyes to cylinder head and attach engine to a suitable hoist.

Remove cap screws and nut (see fig. 4 and 5) attaching flywheel housing to clutch housing.

Remove engine by means of the hoist.

**IMPORTANT:** Move engine properly in line with drive shaft and hollow drive shaft until these shafts come free of the engine dual stage clutch disks, or free of clutch disk and torsion damper if tractor is equipped with a single stage clutch.

#### INSTALLATION

Align engine properly with drive shaft and hollow drive shaft. Move engine towards rear of tractor. Align splines of both shafts with splines of clutch disks (tractor with dual-stage clutch), or (if equipped with a single-stage clutch) with splines of clutch disk and torsion damper. Align screw holes of flywheel housing with holes in clutch housing. Slide engine evenly toward clutch housing, inserting both dowels of flywheel housing in bores of clutch housing, until engine fully contacts clutch housing.

**IMPORTANT:** Make sure flywheel housing is flush against clutch housing before tightening cap screws and hex. nut to specified torque.

Attach cowl to flywheel housing.

Connect speed control rod and shut-off cable to fuel injection pump.

Insert flexible tube of coolant temperature gauge in cylinder head and tighten retaining screw.

Connect three-terminal plug at alternator, and red cable to alternator terminal B+.

Connect cables to starting motor.

Connect cable to oil pressure warning switch.

Install both batteries.

**IMPORTANT:** Connect starter cable to positive poles of batteries.

Lubricate gasket of flexible speed-hour meter shaft and attach shaft to clutch housing (see 2, fig. 4). Make sure driving tab of flexible shaft engages in slot of camshaft. Do not tighten excessively to avoid damage to the gasket resulting in leakage.

*On tractors equipped with starting fluid aid:*  
Connect starting fluid line to intake manifold.

*On tractors equipped with underneath muffler:*  
Install muffler.

Secure oil reservoir leak-off and bleed line to rocker arm cover.

Attach tractor front end to engine.

**IMPORTANT:** Connect ground straps of batteries to negative(-) poles.

*NOTE:* If engine has been overhauled, tune up engine as explained in group 20.

## REMOVAL AND INSTALLATION OF CLUTCH HOUSING

*NOTE:* Separating and joining the tractor between engine and clutch housing as well as between clutch housing and transmission case is explained below. Where the tractor is to be separated depends on the individual repair operation. If, e.g., repair work has to be carried out on the transmission, separation between the clutch housing and the transmission case will be sufficient.

### REMOVAL

Disconnect battery ground straps.

Drain transmission oil.

Separate engine from clutch housing as explained under "REMOVING ENGINE"; the tractor front end may remain attached to the engine.

Disconnect drag link at steering arm.

Disconnect hydraulic oil reservoir leak-off and bleed line (see 5, fig. 6) at transmission shift cover.

Remove clamps (see 4, fig. 2), screw 2 and retainer 1 which secure suction line 5 of hydraulic pump and return line 3 of oil cooler or oil reservoir (if not equipped with oil cooler) to front side of clutch housing.

*On tractors not equipped with Hi-Lo transmission and independent PTO:* Take care not to lose check valve installed in hydraulic pump inlet line when latter is removed.

*On tractors equipped with power steering:*  
Disconnect power steering pressure line at unions.

Remove clamp (see 6, fig. 6) and hydraulic pump pressure line 3.

Insert wooden blocks between front axle and front support to prevent front support from tipping sideways.

Attach JDG-9 support stand to tractor front end. Similarly the rear of tractor should be suspended to a suitable hoist or be supported under the transmission case by means of support stand.

Roll engine and tractor front end away from clutch housing.

**IMPORTANT:** Move engine properly in line with drive shaft and hollow drive shaft until these shafts come free of the clutch disks of the engine dual-stage clutch, or on tractors with single-stage clutch, free of clutch disk and torsion damper.

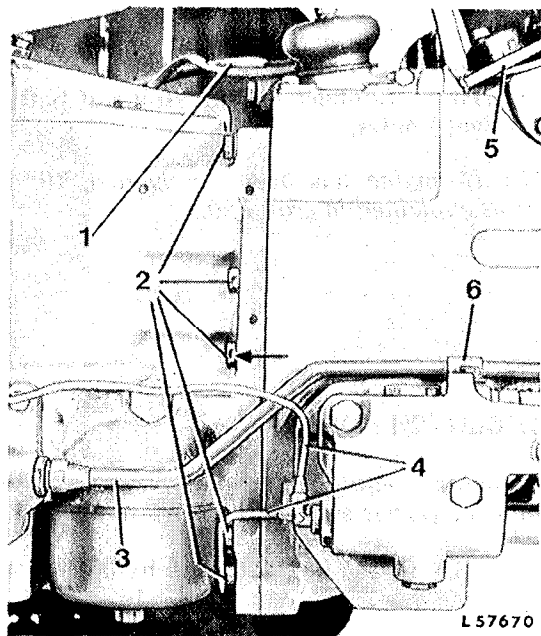

Fig. 6 — Separating between Clutch Housing and Transmission Case, R. H. Side

- |                                |   |
|--------------------------------|---|
| 1 Rear wiring harness          | 5 Hydraulic oil reservoir leak-off and bleed line |
| 2 Attaching screws             | 6 Pipe clamp                                      |
| 3 Hydraulic pump pressure line |   |
| 4 Brake lines                  |   |

Disconnect brake lines (see 4, fig. 6) at brake valve.

Remove transmission shield.

Disconnect rear harness at connector. Disconnect cable at start safety switch.

*On tractors equipped with Hi-Lo shift unit:* Remove cap screws (see 3, fig. 7). Disconnect connecting rod from shaft arm and remove cover 4 complete with shaft.

*On tractors equipped with independent PTO:* Before removing cover (see 4, fig. 7), pull PTO control lever in engaged position. After cover 4 has been removed, do not move PTO control lever otherwise lock balls and springs will drop out of cover.

Remove screws attaching transmission shift cover to clutch housing. Remove transmission shift cover complete with gear shift levers.

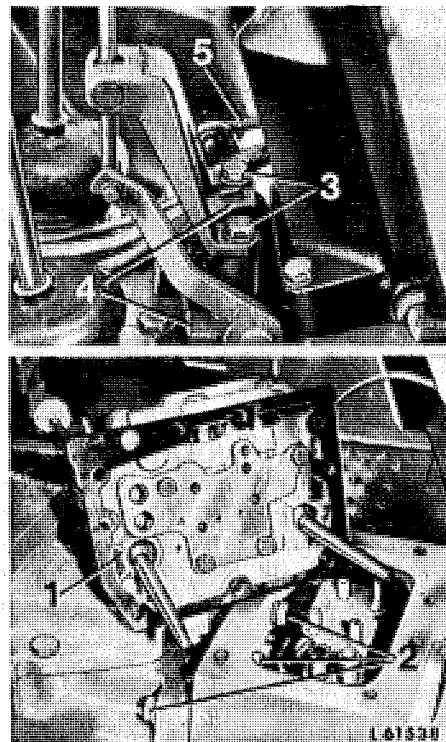

Fig. 7 — Removing Shift Cover

- |                                   |                  |
|-----------------------------------|------------------|
| 1 Shift cover                     | 3 Cap screws     |
| 2 Clutch housing attaching screws | 4 Cover          |
|                                   | 5 Connecting rod |

Remove transmission oil filter.

Remove cap screws 2 (figs. 6 and 7) securing clutch housing to transmission case, and separate clutch housing from transmission case.

Discard seal rings provided between the two housings.

#### INSTALLATION

Install new seal rings in clutch housing front facing transmission case.

Slide clutch housing against transmission case.

Slide PTO drive shaft into needle bearing of clutch housing quill. Mesh PTO gear with hollow PTO drive shaft gear.

Make sure clutch housing is flush against transmission case before tightening cap screws to the specified torque.

*NOTE: Before installing the third (from top) retaining screw at right-hand side of clutch housing (see arrow, fig. 6), coat screw with oil-resistant sealant.*

*NOTE: If clutch housing has also been separated from engine, assemble as explained under "Installation of Engine".*

Insert hydraulic pump inlet line (sec 5; fig. 2) and oil cooler or oil reservoir return line 3 in bore of clutch housing and secure by means of screw and retainer. Tighten screw to the specified torque.

*On tractors not equipped with HIGH-LOW unit and independent PTO: Make sure check valve is inserted in hydraulic pump inlet line before line is installed.*

Install hydraulic pump pressure line.

*On tractors equipped with power steering: Connect power steering pressure line.*

As regards further installation operations reverse removal procedure.

**IMPORTANT:** Connect ground straps of batteries to negative(-) poles.

### REMOVAL AND INSTALLATION OF FINAL DRIVES

#### REMOVAL

*NOTE: The removal of both final drives is explained below. If only one final drive is to be removed, do necessary work only.*

For safety disconnect ground straps at batteries.

Lift up rear of tractor by means of a suitable jack or hoist and remove rear wheels.

**CAUTION:** Support transmission safely to prevent tipping of tractor.

Disconnect rear wiring harness at connector.

Remove rear fender and roll-over guard.

Disconnect brake lines on both final drive housings.

*On tractors equipped with selective control valve(s):* Disconnect hydraulic lines and remove both screws securing bracket to the right-hand final drive housing.

Cover connections and exposed openings with plastic plugs or caps to prevent particles of dirt from entering the system.

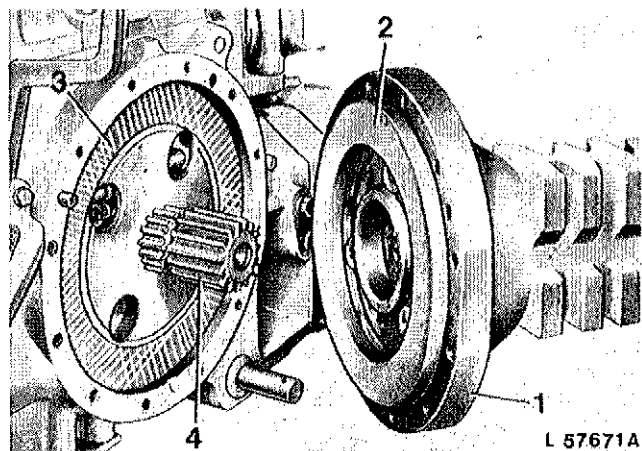

Fig. 8 — Removing Final Drive

- 1 Final drive housing
- 2 Pressure ring
- 3 Brake disk
- 4 Final drive shaft

Remove selective control valve(s).

Attach final drive to hoist. Remove final drive attaching screws. Separate final drive housing from transmission case. Withdraw housing evenly until final drive shaft gear is no longer in mesh with planetary gears of final drive.

## INSTALLATION

*NOTE: If the brake disk was removed, install it with the brass-interwoven upper facing toward brake surface of transmission case.*

Position new gasket between final drive housing and transmission case.

Attach final drive to transmission case by means of a suitable hoist. Make sure final drive shaft gear engages with planetary gears and that the dowels are guided into their respective bores.

Tighten final drive attaching screws to the specified torque.

*On tractors with selective control valve(s):* Attach control valves with bracket to right-hand final drive housing. Connect hydraulic lines.

Connect brake lines and bleed brakes, as explained in section 60, group 15.

Install rear fenders and roll-over guard. Tighten cap screws to specified torque.

Connect rear wiring harness at connector.

Install rear wheels and tighten to the specified torque.

**IMPORTANT:** Connect ground straps to negative(-) poles of batteries.

## REMOVAL AND INSTALLATION OF ROCKSHAFT

### REMOVAL

**IMPORTANT:** Work on the hydraulic system requires extreme care and cleanliness. Minute dirt or foreign particles, scratches, nicks or burrs may put the hydraulic system out of function. Before removing the rockshaft, check hydraulic system for leaks.

For safety, disconnect ground straps from batteries.

Remove transmission shield. Disconnect cable 1 (fig. 9) from start safety switch.

Remove operator's seat. Disconnect both lift links at lift arms.

Disconnect oil return line (see 2, fig. 9) of selective control valves (if equipped) at union on rockshaft.

Remove pressure lines 3 (tractors equipped with selective control valve).

Free rear wiring harness 4.

Disconnect socket cable 5 at connector.

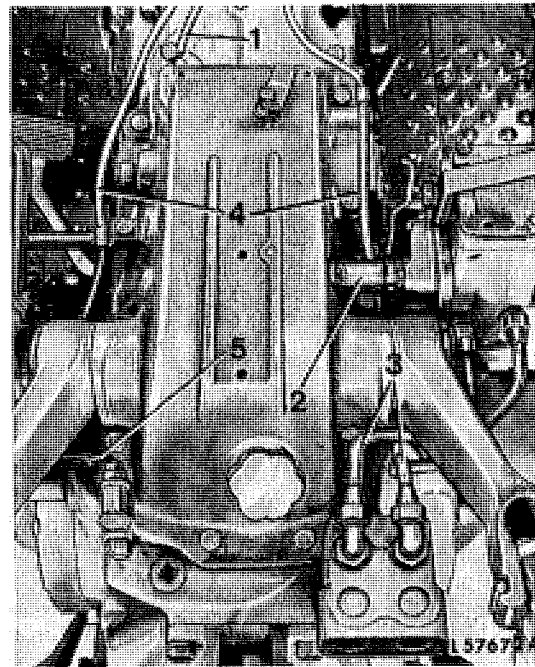

Fig. 9 — Rockshaft, Installed

- |  |                                  |
|--|----------------------------------|
| 1 Cable of start safety switch                                     | 4 Rear wiring harness            |
| 2 Oil return line  | 5 Cable to socket (for handlamp) |
| 3 Pressure lines to coupler (tractor with selective control valve) |                                  |

Move selector lever in position "L" (load control) so that the control linkage roller slides along the cam of the control arm when removing the rockshaft.

Attach engine lifting eye No. JD 244-2 to top of rockshaft housing.

Remove rockshaft attaching screws. Lift rockshaft assembly off transmission case by means of a hoist.

Take care not to damage rear harness.

*NOTE: After removing rockshaft, cover transmission case to prevent foreign particles from falling into the transmission.*

**INSTALLATION**

Use a new gasket between transmission case and rockshaft. Make sure dowels in transmission case and seal ring of oil inlet passage are installed.

Move selector lever in position "L" so that the control linkage with roller can be slid over the cam.

Lift rockshaft on transmission case, using a suitable hoist.

If equipped: Connect oil return line 2 (fig. 9) of selective control valve to rockshaft housing. Install pressure lines 3.

Tighten rockshaft attaching screws to the specified torque.

Connect cable of start safety switch and hand lamp socket.

Secure rear wiring harness 4 to rockshaft. Install transmission shield on transmission case.

Attach lift links to lift arms. Install operator's seat.

For adjustment of rockshaft see section 70, group 20.

**IMPORTANT: Connect ground straps to negative(-) poles of batteries.**

**TORQUES FOR HARDWARE**

Front support to engine, cap screws		
front cap screws (4 used) . . . . .	230 Nm	170 ft.lbs.
rear cap screws (2 used) . . . . .	180 Nm	130 ft.lbs.
Hydraulic pump drive shaft, clamping screw . . . . .	45 Nm	32 ft.lbs.
Drag link to bell crank or steering arm, slotted nut . . . . .	75 Nm	55 ft.lbs.
Clutch housing to engine, cap screws . . . . .	230 Nm	170 ft.lbs.
Clutch housing to transmission, cap screws . . . . .	120 Nm	85 ft.lbs.
Retainer of hydraulic lines to clutch housing, cap screw . . . . .	45 Nm	32 ft.lbs.
Final drive housings to transmission case, cap screws . . . . .	120 Nm	85 ft.lbs.
Roll-over guard cap screws (tighten crosswise)		
1. Step . . . . .	70 Nm	50 ft.lbs.
2. Step . . . . .	400 Nm	300 ft.lbs.
Rockshaft housing to transmission case, cap screws . . . . .	120 Nm	85 ft.lbs.
Rear wheels to rear axle, wheel bolts . . . . .	180 Nm	130 ft.lbs.
Wheel disk to hub (on tractors equipped with rack-and-pinion axle) . . . . .	400 Nm	300 ft.lbs.

\* *NOTE: If cotter pin cannot be inserted when tightening to the specified torque, turn nut to next slot and secure with cotter pin.*

SPECIAL TOOLS

No.	Description	Use
JDG-1*.....	Engine sling .....	Engine removal
JD 244-1* .....	Lifting eye, straight .....	Removing and installing assemblies
JD 244-2* .....	Lifting eye, bent .....	ditto
JDG-9* .....	Support stand .....	Separating tractor

\* SERVICE TOOLS, BOX 314, OWATONNA, MINNESOTA 55060



# Section 20 ENGINE

## CONTENTS OF THIS SECTION

	Page
<b>GROUP 5 — GENERAL INFORMATION, DIAGNOSING MALFUNCTIONS</b>	
General information . . . . .	5-2
Diagnosing malfunctions . . . . .	5-2
<b>GROUP 10 — CYLINDER HEAD AND CAM-SHAFT</b>	
General information . . . . .	10-1
Cylinder head . . . . .	10-1
Removal . . . . .	10-1
Repair . . . . .	10-2
Installation . . . . .	10-4
Adjusting valve clearance . . . . .	10-4
Camshaft . . . . .	10-5
Removal . . . . .	10-5
Repair . . . . .	10-5
Installation . . . . .	10-6
Specifications . . . . .	10-7
Torques for hardware . . . . .	10-8
Special tools . . . . .	10-8
<b>GROUP 15 — CYLINDER BLOCK, LINERS, PISTONS AND CONNECTING RODS</b>	
General information . . . . .	15-1
Removal . . . . .	15-1
Repair . . . . .	15-1
Assembly . . . . .	15-4
Installation . . . . .	15-4
Specifications . . . . .	15-7
Torques for hardware . . . . .	15-8
Engine break-in . . . . .	15-9
Tune-up data . . . . .	15-9
Special tools . . . . .	15-9
<b>GROUP 20 — CRANKSHAFT, MAIN BEARINGS AND FLYWHEEL</b>	
General information . . . . .	20-1
Removal . . . . .	20-1
Repair . . . . .	20-1
Installation . . . . .	20-4
Specifications . . . . .	20-6
Torques for hardware . . . . .	20-7
Special tools . . . . .	20-7
<b>GROUP 25 — TIMING GEAR TRAIN</b>	
General information . . . . .	25-1
Removal . . . . .	25-1
Repair . . . . .	25-2
Installation . . . . .	25-3
Specifications . . . . .	25-5
Torques for hardware . . . . .	25-6
Special tools . . . . .	26-6
<b>GROUP 30 — ENGINE LUBRICATION SYSTEM</b>	
General information . . . . .	30-1
Removal . . . . .	30-2
Oil pump . . . . .	30-2
Oil pressure regulating valve . . . . .	30-2
Oil cooler . . . . .	30-2
Repair . . . . .	30-3
Oil pump . . . . .	30-3
Oil pressure regulating valve . . . . .	30-4
Oil cooler . . . . .	30-4
Oil filter . . . . .	30-4
Installation . . . . .	30-4
Oil pump . . . . .	30-4
Oil pressure regulating valve . . . . .	30-5
Oil cooler . . . . .	30-5
Oil filter . . . . .	30-4
Adjusting engine oil pressure . . . . .	30-5
Specifications . . . . .	30-5
Torques for hardware . . . . .	30-6
Special tools . . . . .	30-6
<b>GROUP 35 — COOLING SYSTEM</b>	
General information . . . . .	35-1
Diagnosing malfunctions . . . . .	35-2
Repair . . . . .	35-2
Radiator . . . . .	35-2
Adjusting fan belt . . . . .	35-2
Water pump . . . . .	35-2
Checking thermostat . . . . .	35-4
Specifications . . . . .	35-5
Torques for hardware . . . . .	35-5
Special tools . . . . .	35-5
<b>GROUP 40 — SPEED CONTROL LINKAGE</b>	
General information . . . . .	40-1
Removal and disassembly . . . . .	40-1
Repair . . . . .	40-3
Assembly and installation . . . . .	40-3
Adjusting speed control linkage . . . . .	40-4
Specifications . . . . .	40-5

## Group 5

# GENERAL INFORMATION, DIAGNOSING MALFUNCTIONS

20

### GENERAL INFORMATION

The tractor is equipped with a 3-cylinder vertical in-line, valve-in-head, 4-cycle Diesel engine with direct fuel injection.

The "wet" cylinder liners can be replaced one at a time. The pistons are of forged aluminium alloy and cam-ground. Each piston has two single, cast-iron compression rings and one oil control ring. All ring grooves are above the piston pin. The case-hardened piston pins are full floating and are held in place by two snap rings each.

The crankshaft is a one-piece, heat-treated, steel forging. It is supported in four replaceable two-piece main bearings machined to close tolerances.

The connecting rods are provided with a bronze bushing and a two-piece, replaceable bearing cap each.

A camshaft supported in the cylinder block controls the valves and drives the fuel transfer pump.

The intake and exhaust valves are supported in the cylinder head. The valve stems slide in bores in the cylinder head. The rocker arm shaft assembly is fitted on top of the cylinder head.

The engine is supplied with lubricating oil by a gear pump. The lubricating oil passes through a full-flow oil filter in the main oil circuit. To ensure engine lubrication, the oil filter is provided with a by-pass valve which opens when the filter element is restricted. Lubrication oil is cooled by means of an oil cooler.

The engine has a pressure cooling system consisting of the radiator, water pump, multi-blade fan and thermostat.

### DIAGNOSING MALFUNCTIONS

#### ENGINE WILL NOT CRANK

Dead batteries

Bad battery connections

Defective key switch or start safety switch

Starting motor solenoid defective

Starting motor defective

#### ENGINE HARD TO START OR WILL NOT START

Loose or corroded battery connections

Low battery output

Excessive resistance in starter circuit

Too high viscosity crankcase oil

Water, dirt or air in fuel system

Fuel filter restricted

Stuck shut-off knob

Dirty or faulty fuel injection nozzles

Defective injection pump

Defective fuel transfer pump

Shut-off valve at fuel tank closed

Injection pump out of time

#### ENGINE RUNS IRREGULARLY OR STALLS FREQUENTLY

Coolant temperature too low

Insufficient fuel supply

Injection nozzles defective or leaking	LACK OF ENGINE POWER
Fuel filter or fuel lines restricted	Air cleaner restricted or dirty
Defective fuel transfer pump	Excessive resistance in air intake system
Incorrect engine timing	Fuel filter restricted
Improper valve clearance	Defective fuel transfer pump
Cylinder head gasket leaking	Defective fuel injection pump
Worn or broken compression rings	Defective fuel injection nozzles
Valves stuck or burned	Improper crankcase oil
Exhaust system restricted	Engine overheated
Engine compression too low	Engine clutch drags
Engine overheated	Defective cylinder head gasket
Defective fuel injection pump	Lobes of camshaft worn
ENGINE MISSES	Improper valve clearance
Water in fuel	Improper valve timing
Mixture of gasoline and Diesel fuel	Burnt, damaged or stuck valves
Air in fuel system	Worn valve springs
Defective fuel injection nozzles	Incorrect engine timing
Defective fuel injection pump	Piston rings and cylinder liners excessively worn
Fuel injection nozzles improperly installed	Engine compression too low
Leaking fuel injection nozzle seals	Improper coolant temperature
Engine overheated	ENGINE OVERHEATS
Lobes of camshaft worn	Lack of coolant in cooling system
Worn valve springs	Radiator core and/or side grille screens dirty
Worn or defective fuel transfer pump	Loose or defective fan belt
Detonation or pre-ignition	Defective thermostat
Incorrect engine timing	Cooling system limed up
Engine compression too low	Engine overloaded
Improper valve clearance	Fuel injection pump delivers too much fuel
Burned, damaged or stuck valves	Damaged cylinder head gasket

Incorrect engine timing

Defective water pump

Too low crankcase oil level

Defective radiator cap

#### HIGH OIL CONSUMPTION

Oil control rings worn or broken

Scored cylinder liners or pistons

Excessive resistance in air intake system

Oil flow through oil passages restricted

Worn valve guides or stems

Too low viscosity crankcase oil

Excessive oil pressure

Piston ring grooves excessively worn

Piston rings sticking in ring grooves

Insufficient piston ring tension

Piston ring gaps not staggered

Excessive main or connecting rod bearing clearance

Crankcase oil level too high

External oil leaks

Front and rear crankshaft oil seal faulty

#### LOW OIL PRESSURE

Low crankcase oil level

Leakage at internal oil passage

Defective oil pump

Excessive main and/or connecting rod bearing clearance

Improper regulating valve adjustment

Improper crankcase oil

Defective oil pressure warning switch or indicator light

#### HIGH OIL PRESSURE

Stuck or improperly adjusted regulating valve

Stuck or damaged filter by-pass valve

#### EXCESSIVE FUEL CONSUMPTION

Engine overloaded

Compression too low

Leaks in fuel system

Air cleaner restricted or dirty

Fuel injection nozzles dirty or faulty

Fuel injection pump defective (delivers too much fuel)

Incorrect engine timing

#### BLACK OR GREY EXHAUST SMOKE

Excess fuel

Engine overloaded

Air cleaner restricted or dirty

Defective muffler (causing back-pressure)

Fuel injection nozzles dirty or faulty

Incorrect engine timing

#### WHITE EXHAUST SMOKE

Engine compression too low

Defective fuel injection nozzle

Incorrect engine timing

Thermostat defective

#### COOLANT IN CRANKCASE

Cylinder head gasket defective

Cylinder head or block cracked

Cylinder liner seals leaking



**Download the full PDF manual instantly.**

**Our customer service e-mail:**

**[aservicemanualpdf@yahoo.com](mailto:aservicemanualpdf@yahoo.com)**