

TM2328 Energy Wood Harvester 1490D

TECHNICAL MANUAL TM2328

TM2328 15JAN05 (ENGLISH)

For complete service information also see:

1490D Operator's Manual	OMF069420
Deere engine 6068 HTJ77 Manual	CTM 104
Fuel system Manual for 4,5 and 6.8 l diesel engines	CTM 331
TMC Workshop	OMF064497
Timbermatic 700 / 900	OMF069483

**Worldwide Construction
And Forestry Division**

Introduction

Foreword

This manual is written for an experienced technician. Essential tools required in performing certain service work are identified in this manual and are recommended for use.

Live with safety: Read the safety messages in the introduction of this manual and the cautions presented throughout the text of the manual.

: This is the safety-alert symbol. When you see this symbol on the machine or in this manual, be alert to the potential for personal injury.

This technical manual is concise guide for specific machine type. This is on-the-job guide containing only the vital information needed for diagnosis, analysis, testing, and repair.

Fundamental service information is available from other sources covering basic theory of operation, fundamentals of troubleshooting, general maintenance, and basic type of failures and their causes.

OUTJ003,0000344 -19-22JAN01-1/1

Serial Numbers

This Manual covers the following range of Forwarders serial numbers:

- WJ1490D002012...

JK11466,0000003 -19-14AUG03-1/1

John Deere Contact Information

Please, contact our web site: www.johndeere.com.

EL62757,000015B -19-19APR02-1/1

Contents

SECTION 00—General Information

- Group 0010—Safety features
- Group 0020—Safety - General Safety Precautions
- Group 0030—Safety - Operating Precautions
- Group 0040—Safety - Maintenance Precautions
- Group 0050—Specifications - General
- Group 0051—Specifications - Base Machine
- Group 0052—Specifications - Power Train
- Group 0053—Specifications - Hydraulics
- Group 0054—Specifications - Tires
- Group 0054—Specifications - Booms
- Group 0055—Specifications - Maintenance
- Group 0056—Specifications - Fluids and Lubricants
- Group 0057—Transporting and Towing

SECTION 01—Wheels

- Group 0110—Wheels Service

SECTION 02—Power Train

- Group 0210—Theory of Operation
- Group 0220—Transfer case (High / Low Gear)
- Group 0230—Drive shaft
- Group 0235—Drive Lines Troubleshooting
- Group 0240—Axles / Bogie
- Group 0245—NAF Service Manuals and Repair instructions
- Group 0250—Brakes - General
- Group 0255— Brakes - Service
- Group 0256—Brake Hydraulics Troubleshooting

SECTION 03—Hydraulic systems

- Group 0310—General
- Group 0315—Hydraulic Cooling System Troubleshooting
- Group 0320—Drive Hydraulics Service
- Group 0325—Checking and Adjusting Drive Hydraulics
- Group 0326—Hydrostatic Drive System Troubleshooting
- Group 0327—Hydrostatic Drive Pump Troubleshooting
- Group 0328—Hydrostatic Drive Motor Troubleshooting
- Group 0330—Work Hydraulics
- Group 0335—Work Hydraulics Service

- Group 0340—Work Hydraulics Checking and Adjusting
- Group 0350—Hydraulic Cylinders
- Group 0380—Hydraulic System - Appendix Manuals

SECTION 031—Hydraulic Diagrams

- Group 031-1—Hydraulic Diagrams

SECTION 04—Engine

- Group 0410—Engine mounting and dismounting
- Group 0420—Engine
- Group 0430—Engine Troubleshooting

SECTION 16—Electrical-System

- Group 1610—Main Electrical System
- Group 1630—Electrical Sensors
- Group 1640—Control Systems
- Group 1660—Alternator
- Group 1680—Starter Motor

SECTION 1615—Electrical Schematics

- Group 1615-1—Electrical Schematics

SECTION 17—Frames

- Group 1710—Frame installation
- Group 1720—Frame Hinge
- Group 1730—Service - Frame Joint
- Group 1740— Service - Frame Brake
- Group 1750—Operational Checks
- Group 1760—Steering

SECTION 18—Cabin

- Group 1810—Cabin Environment
- Group 1820— Cabin Service
- Group 1830—Cab Tilt Hydraulics Troubleshooting

SECTION 19—Heating and Air Conditioning System

- Group 1910—General
- Group 1920—Air Conditioning / Heater Components
- Group 1930—Diagnosing Air Conditioning / Heater System

Continued on next page

00

01

02

03

031

04

16

1615

17

18

00 **SECTION 37 —Boom**

- Group 3710— Boom - General
- Group 3720—Boom - Installation
- Group 3730—Boom Parts- Removal and Installation
- 01 Group 3740—Boom Components - Removal and installation
- Group 3750—Boom - Diagnostic Information
- Group 3760—Boom - Overall maintenance

02 **SECTION 38—Decking Blade**

- Group 3810—General
- Group 3820— Removal and Installation
- Group 3830—Service
- Group 3840—Diagnostic information

03 **SECTION 40—Grapple**

- Group 4010—Theory of Operation
- Group 4020—Removal and Installation
- Group 4030—Grapple Service
- Group 4040—Grapple Rotator
- Group 4050—Diagnostics

031 **SECTION 44—Bundler Unit**

- Group 4410— General
- Group 4420—Componets
- Group 4430—Diagnostic Information
- Group 4440—Overall maintenance
- 04 Group 4450-1—Repairs - Saw Unit
- Group 4450-2—Repairs - Twine magazine
- Group 4450-3—Repairs - Compactor Units
- Group 4450-4—Repairs - Swing Unit
- Group 4450-5—Repairs - Feed motor
- 16 Group 4450-6—Repairs - Sensors

SECTION 45—Tool Drawings

- Group 4510—Dealer Fabricated Tools

1615 **SECTION 80—Optional Equipments**

- Group 8010— Engine Preheater
- Group 8030—Fire Extinguisher
- Group 8040—Tropical Kit
- Group 8050—Extra fuel tank

Section 00 General Information

Contents

	Page		Page
Group 0010—Safety features			
Decals and Signs	00-0010-1	Use Proper Tools	00-0040-4
1490D Safety Features	00-0010-2	Support Machine Properly	00-0040-4
Driving and Service	00-0010-3	Shut Down Engine, Disconnect Battery Cable	00-0040-5
Group 0020—Safety - General Safety Precautions			
General	00-0020-1	Service Cooling System Safely	00-0040-5
Recognize Safety Information	00-0020-1	Prevent Battery Explosions	00-0040-5
Understand Signal Words	00-0020-1	Prevent Acid Burns	00-0040-6
Prepare for Emergencies	00-0020-2	Replacing the Xenon Worklamp	00-0040-7
Wear Protective Clothing	00-0020-2	Start Only from Operator's Seat	00-0040-7
Handle Fluids Safely—Avoid Fires	00-0020-3	Beware of Exhaust Fumes	00-0040-8
Handle Chemical Products Safely	00-0020-3	Avoid High Pressure Fluids	00-0040-8
Replace Safety Signs	00-0020-4	Avoid Heating near Pressurized Fluid Lines	00-0040-9
Maintain Safety Cabin	00-0020-4	Make Welding Repairs Safely	00-0040-9
Use of Radio-transmitters	00-0020-5	Service Tires Safely	00-0040-10
Group 0030—Safety - Operating Precautions			
Inspect machine	00-0030-1	Refueling and Servicing Fuel System	00-0040-10
Attach Do not Operate Tag	00-0030-1	Dispose of Waste Properly	00-0040-11
Prevent Machine Runaway	00-0030-2	Group 0050—Specifications - General	
Use Handholds and Steps	00-0030-2	Use Proper Tools	00-0050-1
Secondary exit	00-0030-3	General Component Locator	00-0050-2
Handle Starting Fluid Safely	00-0030-4	Machine Dimensions	00-0050-3
Pay Attention to Bystanders	00-0030-4	Bundler Unit Dimensions	00-0050-4
Carry no passengers	00-0030-5	Group 0051—Specifications - Base Machine	
Use Seat Belts	00-0030-5	Base Machine Engine	00-0051-1
Avoid Risks under Difficult Conditions	00-0030-5	Electrical System	00-0051-1
Stop Working if Machine Gives an Alarm	00-0030-6	Group 0052—Specifications - Power Train	
Keep Danger Zone Clear	00-0030-6	Transfer Case	00-0052-1
Precautions During the Sawing	00-0030-7	Axles/Bogies	00-0052-1
Loading the Machine	00-0030-7	Brakes	00-0052-2
Avoid Crush Points	00-0030-7	Group 0053—Specifications - Hydraulics	
Power Cables	00-0030-8	Hydrostatic System Pressures	00-0053-1
Driving/Transporting on Public Roads	00-0030-9	Hydrostatic Drive Pump	00-0053-1
Ensure Safety before Driving on Frozen Water	00-0030-9	Hydrostatic Drive Motor	00-0053-2
Fire Prevention	00-0030-10	Hydraulic System Specifications	00-0053-2
What To Do If the Machine Catches Fire	00-0030-11	Work Pump	00-0053-3
Group 0040—Safety - Maintenance Precautions			
General	00-0040-1	Hydraulic Tank and Filter Specifications	00-0053-3
Precautions while maintaining the Bundler Unit	00-0040-2	Steering	00-0053-4
Securing the Service Position	00-0040-3	Steering and Decking Blade Cylinders	00-0053-4
Use Proper Clothing	00-0040-3	Auxiliary Valve Specifications	00-0053-4

Continued on next page

Page

Multifunction Valve Specification00-0053-5
 Boom valve specifications00-0053-5

Group 0054—Specifications - Tires

General00-0054-1
 Tire pressure00-0054-1

Group 0054—Specifications - Booms

Boom CF51000-0054-1
 Rotator and Grapple00-0054-1

Group 0055—Specifications - Maintenance

Tightening Torque for Bolted Joints00-0055-1
 Unified Inch Bolt and Cap Screw Torque
 Values00-0055-3
 Metric Bolt and Cap Screw Torque
 Values00-0055-5
 Service Recommendations for O-Ring
 Boss Fittings00-0055-6
 Service Recommendations for Flat Face
 O-Ring Seal Fittings00-0055-8
 Service Recommendations For Inch
 Series Four Bolt Flange Fittings00-0055-9
 Service Recommendations for Metric
 Series Four Bolt Flange Fitting00-0055-10
 Metric Flanged Head00-0055-11
 O-ring Fittings00-0055-12
 SAE Code 61 and 62 Flanges00-0055-13
 Tapered Pipe Treads (NPTF and NPT)00-0055-14
 Flare Fittings00-0055-15



**Group 0056—Specifications - Fluids and
 Lubricants**

Recommended Lubricants and Fluids00-0056-1
 Capacities00-0056-2
 Diesel Fuel00-0056-3
 Engine Oil00-0056-6
 Coolant00-0056-7
 Hydraulic oil00-0056-8
 Gear oil00-0056-8
 Saw chain oil00-0056-9
 Brake fluid00-0056-9
 Cab lift pump00-0056-9
 Grease00-0056-9
 Lubricant Storage00-0056-10



Group 0057—Transporting and Towing

Prepare the machine for the
 Transportation00-0057-1

Decals and Signs

		Manufactured by John Deere Forestry Oy P.O.Box 474 FIN-33101 TAMPERE FINLAND			
Type	John Deere 1490D				
Serial No.	WJ1490D002				
Year	200				
Engine power	129	kW			
Typical weight	GW: 20700	kg	BW: 22500	kg	
F635422					

CF510	_____
WJOCF	_____
Year / Vuosi	_____

		Manufactured by John Deere Forestry Oy P.O.Box 474 FIN-33101 TAMPERE FINLAND			
Type	John Deere B380				
Serial No.	WJB380X0002				
Year	200				
Engine power	_____	kW			
Typical weight	7000	kg			
F628792					

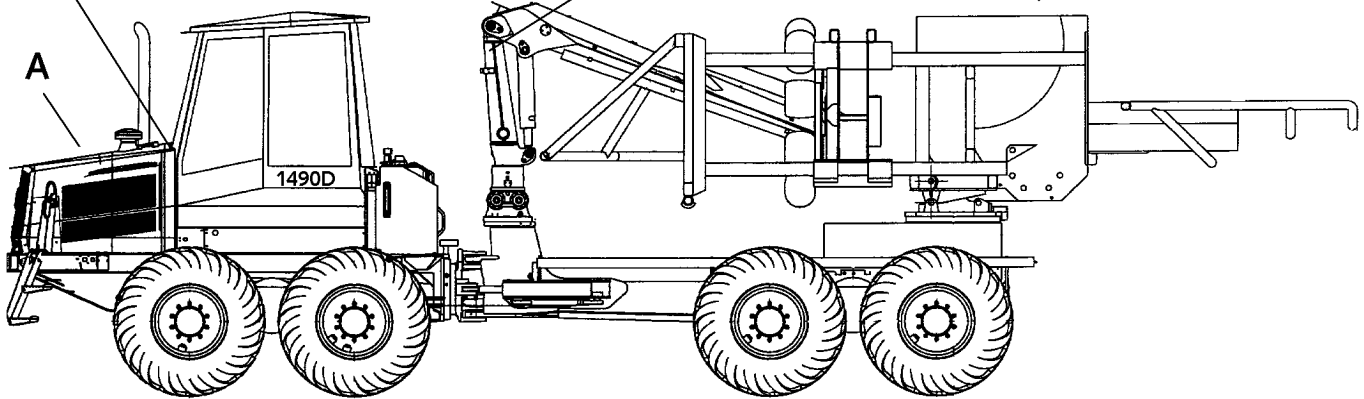

A—Serial number
On the front frame, on the
right side of the machine

T164204 -UN-31MAY05

EL62757,00001E5 -19-22APR02-1/1

1490D Safety Features

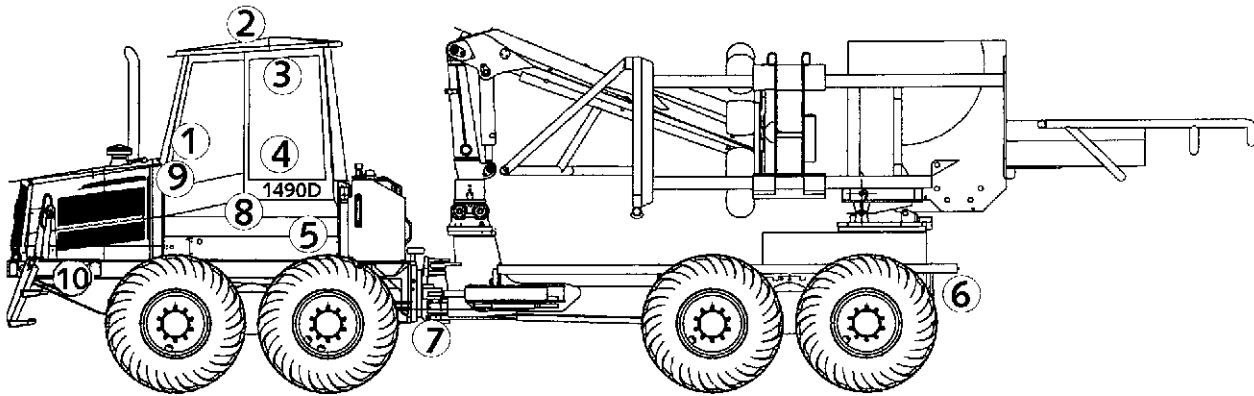

T164206 -UN-20JAN03

- 1—Secondary exit. The right-hand cap window can be used as a secondary exit from the cab.
- 2—ROPS. Integrated rollover and operator protective structures fully enclose and protect the operator
- 3—Central warning light and alarms (+buzzer). Alarm when malfunctions occur.

- 4—Seat safety switch. No function can be engaged before somebody sits on the seat.
- 5—Safety signs. Warn and give safety information for the operator.
- 6—Back-up alarm (opt). Alerts bystanders when machine is reversing.

- 7—Frame brake. Locks the horizontal hinge of the machine.
- 8—Hand-held fire extinguishers and fire extinguisher system (opt.)

- 9—Emergency stop Stops the machine and engages the parking brake.
- 10—Stairs, anti-slips on the steps, handrails. Help to climb into the machine.

Please remember, the Operator is the key to preventing accidents.

OUTJ003,00005CF -19-10MAY01-1/1

Driving and Service

The machine may only be used or repaired by personnel who have received training that is approved by John Deere.

IMPORTANT: Do not let an untrained person operate the machine.

- Carry no passengers. The vehicle is provided and approved with seating for the operator only.
- Use the handrails and steps provided when mounting and dismounting from the machine. Do not climb onto the machine in any other fashion.
- The machine must not be operated by anyone under the influence of alcohol or drugs.
- Avoid operating the machine if you are tired or ill, as there is a greater risk of accident. Take sufficient breaks and observe local regulations on working hours.

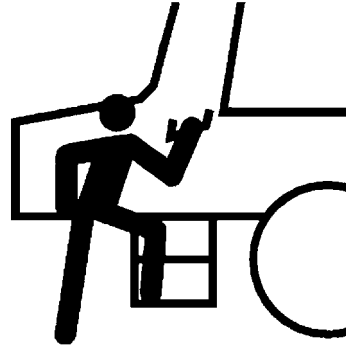

T1152788 -UN-20MAR02

EL62757,000015F -19-19APR02-1/1

General

IMPORTANT: See Group 0030 for tightening torques. See also enclosed NAF and Rexroth manuals for detailed service instructions

IMPORTANT: Cleanliness procedures must be observed when working on any hydraulic component in order to prevent contamination of the hydraulic and hydrostatic systems.

Failure to follow these procedures may lead to equipment damage.

Use an air hose and wire brush to remove any loose dirt and debris from the outside of the motor before starting any work.

Plug all ports to prevent contamination.

JK11466,0000078 -19-03JAN03-1/1

03
0320
1

Essential Tools

NOTE: Order tools according to information given in the U.S. SERVICEGARD™ Catalog or from the European Microfiche Tool Catalog (MTC).

Drive motor

SERVICEGARD is a trademark of Deere & Company

OUTJ003,0000313 -19-18JAN01-1/8

Driver, Drive Shaft Seal Part Number N/A

Used to press fit Drive Shaft Seal on Hydrostatic Drive Motor.

OUTJ003,0000313 -19-18JAN01-2/8

Drive Pump

Continued on next page

OUTJ003,0000313 -19-18JAN01-3/8

Drive Hydraulics Service

Driver, Drive Shaft Seal Part Number N/A

Used to press fit Drive Shaft Seal on Hydrostatic Drive Pump.

OUTJ003,0000313 -19-18JAN01-4/8

Spring Preloading Cylinder Part number N/A

Used to preload spring while installing retaining rings on Hydrostatic Drive Pump Control Piston

OUTJ003,0000313 -19-18JAN01-5/8

Rotary Group Assembly Tool Part Number N/A

Used to position cylinder during installation of Rotary Group in Hydrostatic Drive Pump housing.

OUTJ003,0000313 -19-18JAN01-6/8

Connecting Hose

Used to connect Ports X1 and X2 during Mechanical Centering of Hydrostatic Drive Pump procedure.

OUTJ003,0000313 -19-18JAN01-7/8

OUTJ003,0000313 -19-18JAN01-8/8

Service Equipment

Drive Motor

NOTE: Order tools according to information given in the U.S. SERVICEGARD™ Catalog or from the European Microfiche Tool Catalog (MTC). Some tools may be available from a local supplier.

SERVICEGARD is a trademark of Deere & Company

OUTJ003,0000314 -19-18JAN01-1/6

Gauge 5.0 MPa (1000 psi)

Used to measure hydraulic pressures at test ports.

OUTJ003,0000314 -19-18JAN01-2/6

Continued on next page

03
0320
2

Drive Hydraulics Service

NOTE: See Section 00, group 0020 for all specifications

Drive Pump

NOTE: Order tools according to information given in the U.S. SERVICEGARD™ Catalog or from the European Microfiche Tool Catalog (MTC). Some tools may be available from a local supplier.

SERVICEGARD is a trademark of Deere & Company

OUTJ003,0000314 -19-18JAN01-3/6

Two Gauges 60 MPa (9000 psi)

To measure hydraulic pressure at test port.

OUTJ003,0000314 -19-18JAN01-4/6

03
0320
3

Gauge 5.0 MPa (1000 psi)

To measure hydraulic pressure at test port.

OUTJ003,0000314 -19-18JAN01-5/6

OUTJ003,0000314 -19-18JAN01-6/6

Renew the pressure filter of the drive hydraulic system

1. Lift the cabin. The transmission filter is located above the transmission pump.
2. Turn filter counterclockwise to remove.
3. Clean mounting surface. Apply thin film of oil to gasket of new filter.
4. Install new filter. Turn the filter by hand until the seal makes contact with the base. Use a filter wrench to turn the filter 30° further.
5. Start engine. Check for leaks around the filter base. Tighten filter only enough to stop leaks.
6. Stop engine.
7. Check oil level at sight glass on hydraulic tank. Add oil, if necessary. See Section 6-1, for recommended hydraulic fluids.

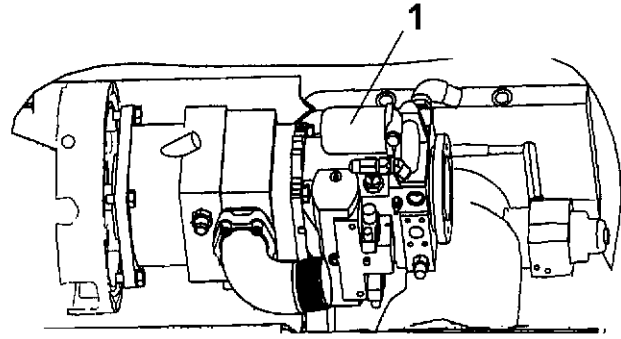

1—Pressure filter

T188481 -JUN-13MAR03

EL62757,0000117 -19-10APR02-1/1

Drive Motor Removal And Installation

CAUTION: Ensure that the engine is stopped and the main switch is in the 'OFF' position. Remove handle from the main switch before disconnecting any hydraulic components. Securely block the wheels to prevent machine movement. Failure to observe proper safety precautions can lead to risk of personal injury.

NOTE: Following service instructions are general only. For detailed instructions for each Forwarder model, see group 0020 page 13 and enclosed Rexroth manuals.

To remove the Hydrostatic Drive Motor:

1. Tag and disconnect the hoses from the hydrostatic drive motor.
2. Attach a suitable lifting device to the Hydrostatic Drive Motor.

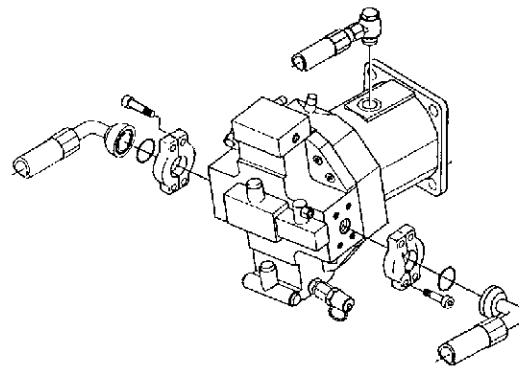

Hydrostatic Drive Motor, Hoses

T138834 -JUN-29AUG01

Continued on next page

OUTJ003,0000304 -19-18JAN01-1/3

- To remove the hydrostatic motor from the transfer case, remove the four socket head capscrews and slide the motor back 75 mm (3") to clear the spline. When the bolts are removed, ensure that the motor is adequately supported at all times to prevent damage to the spline and seals.

To install the hydrostatic Drive Motor:

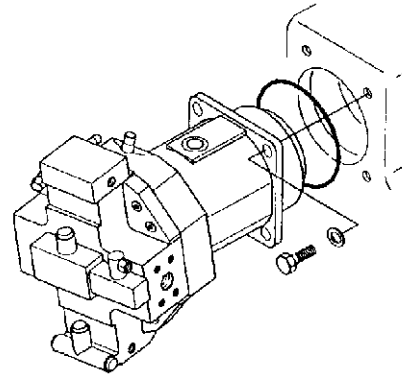

Hydrostatic Drive Motor Removal

T138835 -JUN-29AUG01

03
0320
5

OUTJ003,0000304 -19-18JAN01-2/3

- Replace O-ring before assembly.

Attach the hydrostatic motor to the transfer case with the four socket head capscrews. Tighten screws to specified torque.

- Connect the hoses to the hydrostatic motor.

NOTE: After re-installing or replacing motor, see *Hydrostatic Drive Motor Start-up procedure in Section 03, Group 0320 page 47.*

- 1—Drive Pressure Hose
- 2—Drive Pressure Hose
- 3—Case Drain Hose

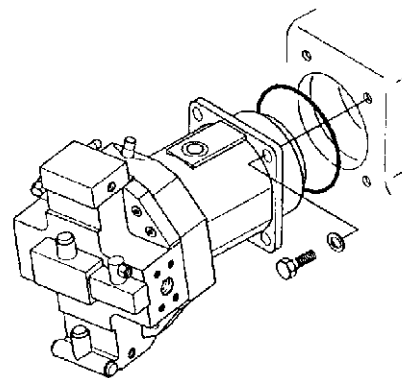

Hydrostatic drive motor Installation

T138835 -JUN-29AUG01

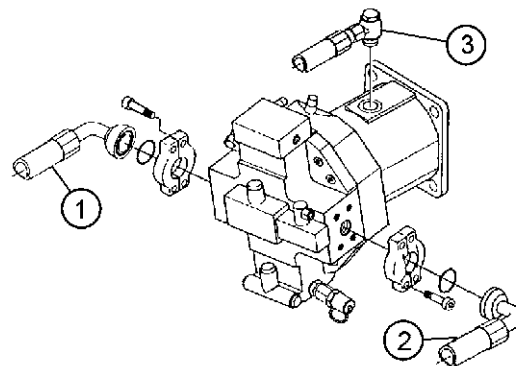

Hydrostatic Drive Motor Hoses

T138837 -JUN-29AUG01

OUTJ003,0000304 -19-18JAN01-3/3

Servicing Drive Motor

Drive Shaft Seals Replacement

- 1—Retaining Ring
- 2—Shim
- 3—Drive Shaft Seal

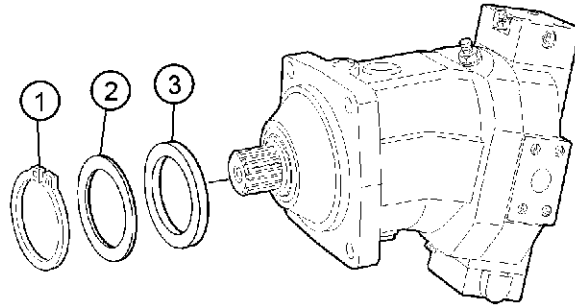

Hydrostatic Drive Motor, Drive Shaft Seal, Shim, Retaining Ring

T138838 -UN-29AUG01

JK11466,00000CE -19-09APR03-1/9

1. Protect the spline by wrapping it with tape.

Remove the retaining ring and shim.

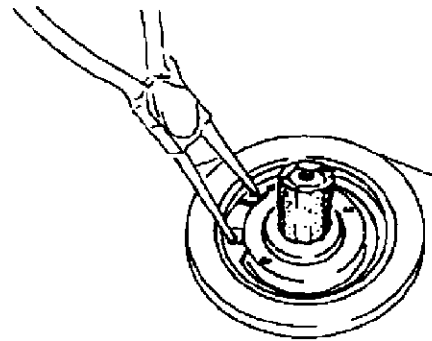

Drive Shaft, Retaining Ring, Pliers

T138839 -UN-29AUG01

Continued on next page

JK11466,00000CE -19-09APR03-2/9

2. Insert two sheet metal screws into the rubber showing at the two holes in the metal backing of the seal. Use the screws as handles to lift out the seal.

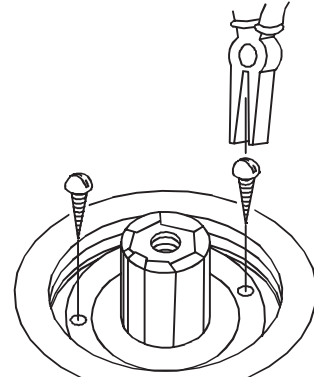

Drive Shaft Seal, Screws, Pliers

T138750 -JUN-20JUL01

03
0320
7

JK11466,00000CE -19-09APR03-3/9

3. Use Seal Driver to press in new seal.

NOTE: Mark the seal depth on the bushing before pressing in the seal.

4. Install the retaining ring and shim.

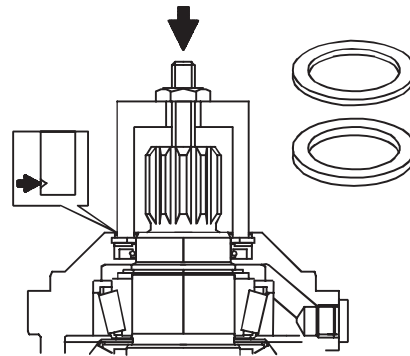

Continued on next page

JK11466,00000CE -19-09APR03-4/9

T138804 -JUN-20JUL01

Constant Pressure Control Valve or Valve Seals Replacement

1. Remove mounting screws to remove valve.

NOTE: Use care when removing valve. Valve is under spring load.

Note the length of the adjustment screw.

NOTE: Do not remove adjustment screw.

2. Replace the o-ring.

3. Lubricate the alignment pin with grease. Install pin on valve.

4. Install valve on Hydrostatic Drive Motor.

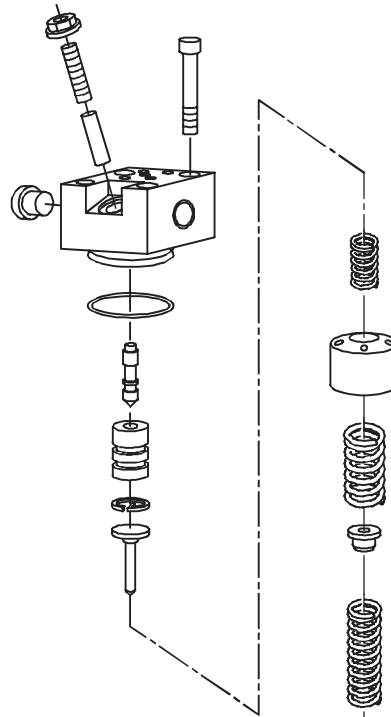

Constant pressure control valve, O-ring

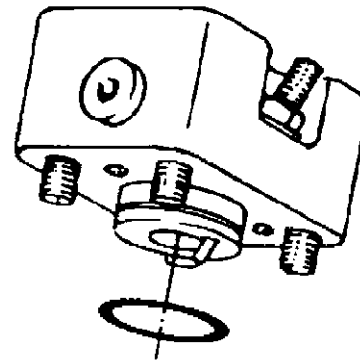

Constant Pressure Control Valve

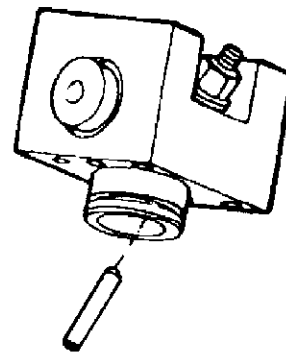

T138843 -UN-20JUL01

T138844 -UN-29AUG01

T138845 -UN-29AUG01

Continued on next page

JK11466,00000CE -19-09APR03-5/9

03
0320
8

Port Plate Seal Replacement

NOTE: In order to disassemble the motor, the rotary group must be swiveled to line up with the output shaft (zero position).

1. Measure and record the setting of the Displacement Limiter Adjustment Screws.

- 1—Minimum Displacement Limiter Screw
- 2—Maximum Displacement Limiter Screw

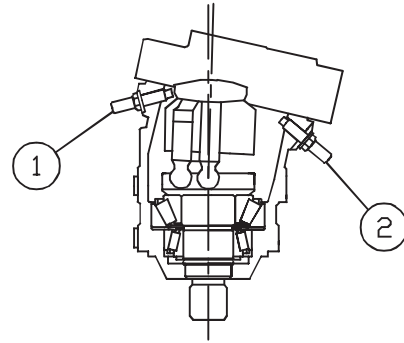

Hydrostatic Drive Motor Section View, Displacement Limiter Screws

T138846 -JUN-20JUL01

03
0320
9

JK11466,00000CE -19-09APR03-6/9

2. Remove the Minimum Displacement Limiter Screw and plug the port.

Remove the Maximum Displacement Limiter Adjustment Screw.

3. Install a long screw in the maximum displacement limiter port and swivel the rotary group to the zero position.

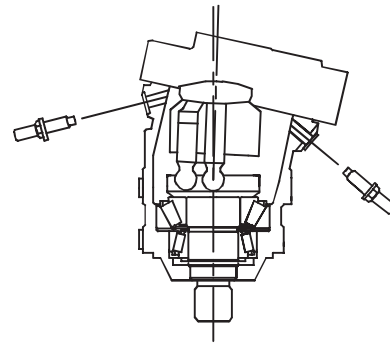

Hydrostatic Drive Motor Section View, Displacement Limiter Screws Removal

T138847 -JUN-20JUL01

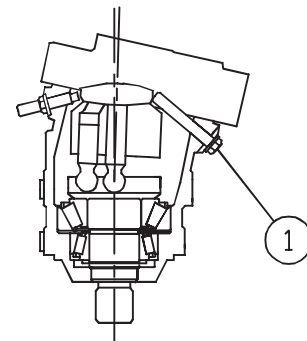

Hydrostatic Drive Motor Section View, Long Screw, Swivel Rotary Group

T138850 -JUN-20JUL01

Continued on next page

JK11466,00000CE -19-09APR03-7/9

4. Mark the position of the port plate to ease re-assembly.

Remove the mounting screws.

Remove the port plate.

5. Replace the o-ring. Apply a coating of grease to new o-ring to hold it in place.

NOTE: Keep the rotary group vertical. The piston rings should project beyond the cylinder bores.

6. Inspect the sliding surfaces of the control lens and port plate.

7. Install port plate. Use a coating of grease to hold the control lens in position. Install mounting screws.

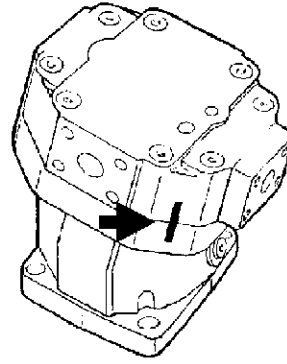

Hydrostatic drive Motor, Alignment Mark

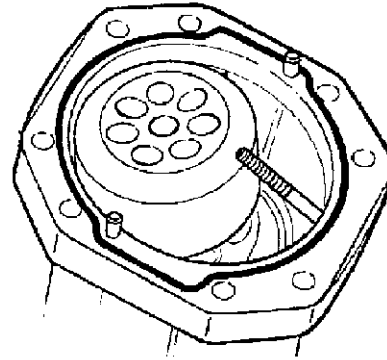

Hydrostatic Drive Motor Housing, Port Plate Removed, Seal

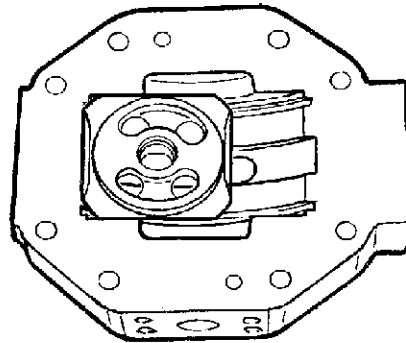

T138851 -UN-29AUG01

T138852 -UN-29AUG01

T138853 -UN-29AUG01

Continued on next page

JK11466,00000CE -19-09APR03-8/9

03
0320
10

8. Install Minimum Displacement Limiter. Confirm that it is installed to the correct depth.

Remove long screw from Maximum Displacement Limiter port. Install Maximum Displacement Limiter. Confirm that it is installed to the correct depth.

NOTE: The start-up procedure should always be followed when the hydrostatic pump or motor has been removed or replaced.

See the *Hydrostatic Pump and Motor Start-up Procedure* in Group 0320.

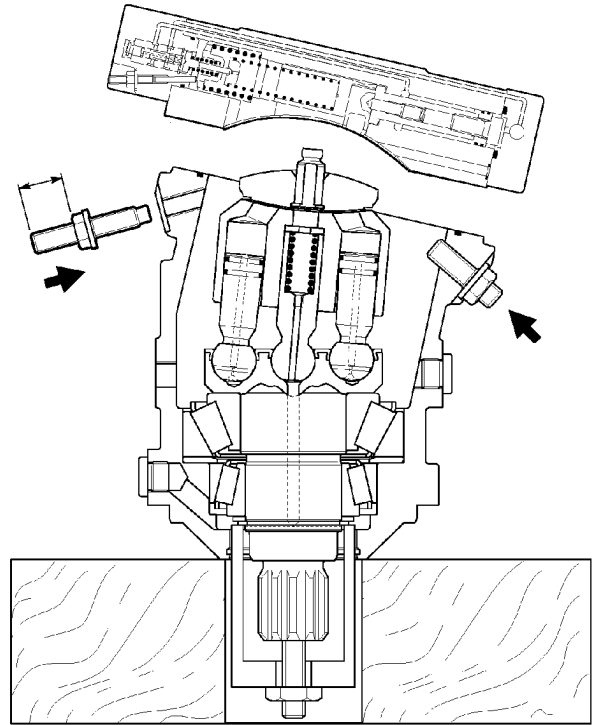

Hydrostatic Drive Motor Section View, Displacement Limiter Installation

T138864 -JUN-29AUG01

03
0320
11

Drive Pump Removal and Installation

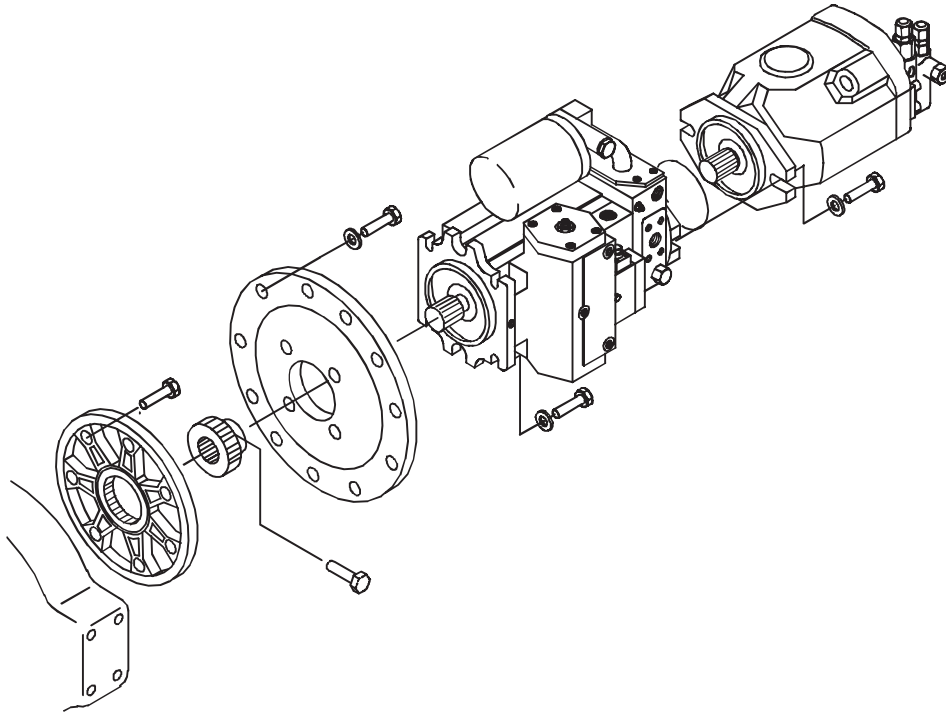

Coupling, Hydrostatic Drive Pump, Work Pump

IMPORTANT: Cleanliness procedures must be observed when working on any hydraulic component in order to prevent contamination of the hydraulic and hydrostatic systems.

Failure to follow these procedures may lead to equipment damage.

The hydrostatic drive pump and the working pump are removed from the machine as an assembly. See Section 02, Group Drive Coupling Removal and Installation, for details.

It is recommended that the machine be completely washed down before removal begins.

Tag all hoses before removal to ease re-assembly.

Cap hoses and plug ports.

The hydrostatic pump must be taken to a hydraulic repair shop for repair where all the tools and expertise are available.

T138747 -UN-20JUL01

OUTJ003,00002E6 -19-17JAN01-1/1

Servicing Drive Pump

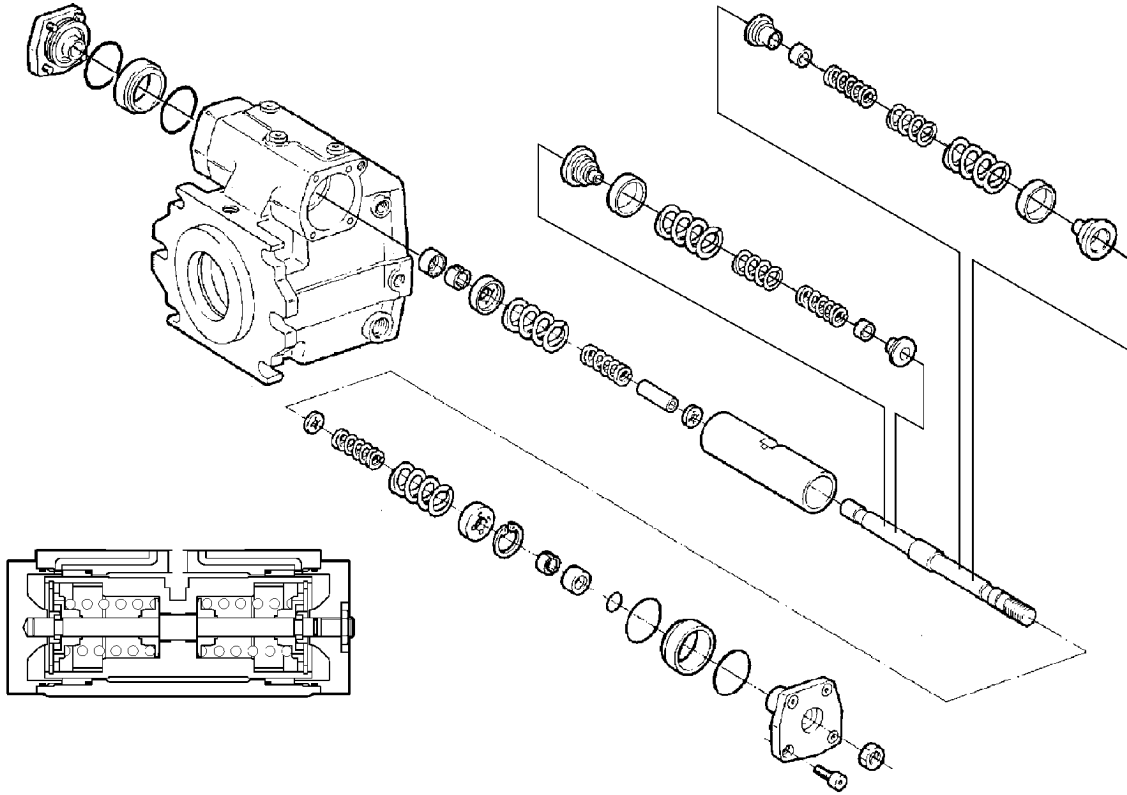

An example of drive pump assembly

JK11466,00000CF -19-09APR03-1/78

03
0320
13

T138784 -UN-13AUG01

Drive Shaft Seal Replacement

- 1—Retaining Ring
- 2—Drive Shaft Seal

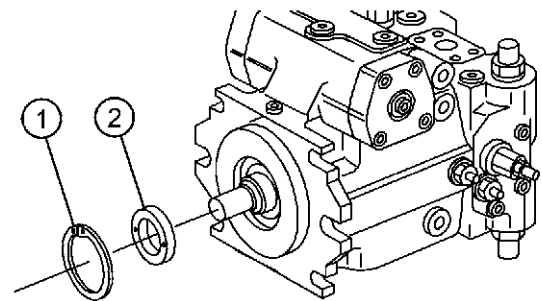

Hydrostatic Drive Pump - Drive Shaft Seal

T138748 -UN-13AUG01

Continued on next page

JK11466,00000CF -19-09APR03-2/78

1. Protect the drive shaft spline by wrapping it with tape.
2. Use pliers to remove the retaining ring.

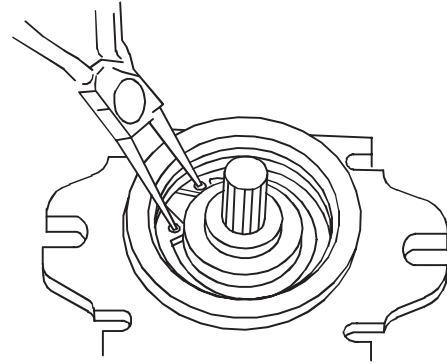

Retaining Ring Removal

T138749 -UN-20JUL01

JK11466.00000CF -19-09APR03-3/78

3. Insert two sheet metal screws into the rubber showing at the two holes in the metal backing of the seal. Use the screws as handles to lift out the seal.

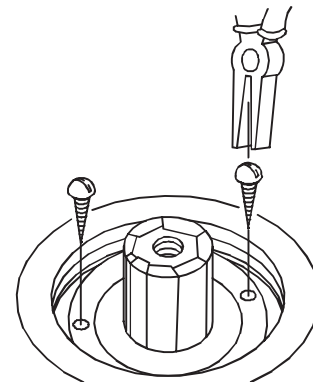

Drive Shaft Seal Removal

T138750 -UN-20JUL01

Continued on next page

JK11466.00000CF -19-09APR03-4/78

4. Use seal driver to press in the new seal.

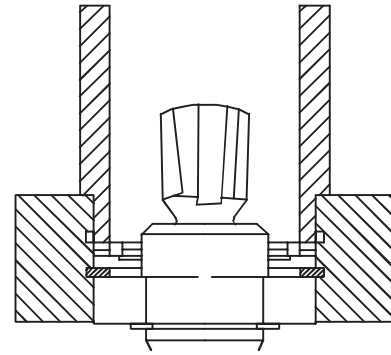

Drive Shaft Seal Installation

T138751 -JUN-20JUL01

03
0320
15

JK11466,00000CF -19-09APR03-5/78

5. Use pliers to install the retaining ring.

6. Remove the tape from the drive shaft spline.

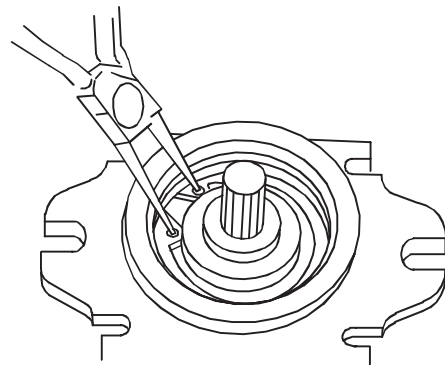

Retaining Ring Installation

T138749 -JUN-20JUL01

Continued on next page

JK11466,00000CF -19-09APR03-6/78

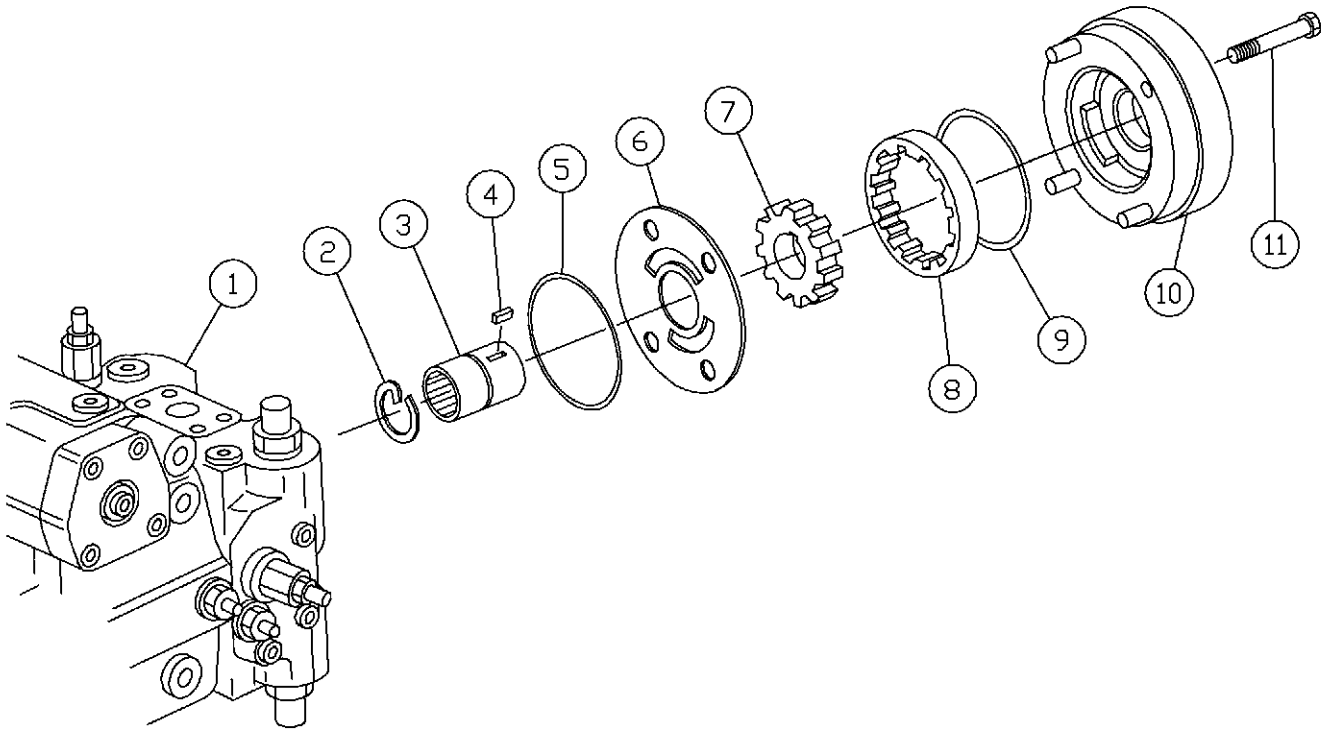

Charge Pump

- | | | | |
|--------------------------|---------------|---------------|------------|
| 1—Hydrostatic Drive Pump | 4—Key | 7—Pinion Gear | 10—Housing |
| 2—Retaining Ring | 5—O-ring | 8—Driven Gear | 11—Screw |
| 3—Pinion Gear Shaft | 6—Valve Plate | 9—O-ring | |

Charge Pump

JK11466.00000CF -19-09APR03-7/78

1. Mark the position of the cover plate to ease re-assembly.
2. Remove the mounting screws.
3. Pry off the cover.
4. Remove and discard the seals.

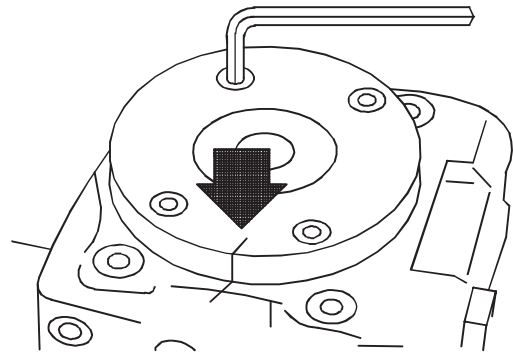

Charge Pump Hosing Alignment Mark

Continued on next page

JK11466.00000CF -19-09APR03-8/78



Download the full PDF manual instantly.

Our customer service e-mail:

aservicemanualpdf@yahoo.com