

# 335, 375, 385, 435 and 535 Round Balers



## TECHNICAL MANUAL 335, 375, 385, 435 and 535 Round Balers

TM1472 (06NOV95) English

**John Deere Ottumwa Works**  
**TM1472 (06NOV95)**

LITHO IN U.S.A.  
ENGLISH



# Contents

## SECTION 10—GENERAL

- Group 05—Safety
- Group 10—Specifications
- Group 15—General Information
- Group 20—Lubrication

## SECTION 20—Drive Train

- Group 05—General Information
- Group 10—Diagnosing Malfunctions
- Group 15—Drive Train Protection
- Group 20—PTO Hookup
- Group 25—Gear Case Repair
- Group 30—Rolls and Roll Drives

## SECTION 30—HYDRAULICS

- Group 05—General Information
- Group 10—Diagnosing Malfunctions
- Group 15—335, 375 and 385 Hydraulic System and Tests
- Group 20—335, 375 and 385 Tensioning Valve Repair
- Group 25—335, 375 and 385 Hydra-Selector Valve
- Group 30—435 and 535 Hydraulic System and Tests
- Group 35—435 and 535 Single Spool Valve
- Group 40—Cylinders

## SECTION 40—TWINE MECHANISM

- Group 05—Diagnosing Malfunctions
- Group 10—335, 375 and 385 Twine Wrap System
- Group 15—435 and 535 Automatic Twine Wrap System

## SECTION 50—SURFACE WRAP SYSTEM (SERIAL NO. —CC010000)

- Group 05—Diagnosing Malfunctions
- Group 10—Diagnosing Malfunctions
- Group 15—Surface Wrap Repair

## SECTION 51—SURFACE WRAP SYSTEM (SERIAL NO. 880001— )

- Group 05—General Information
- Group 10—Diagnosing Malfunctions
- Group 15—Surface Wrap Repair

## SECTION 60—ELECTRICAL

- Group 05—General Information
- Group 10—Diagnosing Malfunctions
- Group 15—435/535 Electrical Diagnostics
- Group 20—Tests and Adjustments
- Group 25—Electrical Diagrams

## SECTION 70—PICKUP

- Group 05—Diagnosing Malfunctions
- Group 10—Pickup Repair

## SECTION 80—MISCELLANEOUS

- Group 05—Wheel Repair
- Group 10—Gate Repair
- Group 15—335 and 375 Tension Arm Repair
- Group 16—385 Tension Arm Repair
- Group 20—435 and 535 Tension Arm Repair
- Group 25—Tongue
- Group 30—Belt Repair
- Group 35—Main Frame Repair

## Index

*All information, illustrations and specifications in this manual are based on the latest information available at the time of publication. The right is reserved to make changes at any time without notice.*

TM1472-19-06NOV95

COPYRIGHT© 1995  
DEERE & COMPANY  
Moline, Illinois

All rights reserved  
A John Deere ILLUSTRATION™ Manual  
Previous Editions  
Copyright 1993, 1992, 1989 Deere & Company

# Section 10 GENERAL

10

## Contents

|  | Page    |
|--|---------|
| <b>Group 05—Safety</b> .....               | 10-05-1 |
| <b>Group 10—Specifications</b>             |         |
| 335, 375 and 385 Round Balers .....        | 10-10-1 |
| 435 and 535 Round Balers .....             | 10-10-3 |
| Cap Screw Torque Values .....              | 10-10-5 |
| <b>Group 15—General Information</b>        |         |
| 335, 375 and 385 Baler Description .....   | 10-15-1 |
| 435 and 535 Baler Description .....        | 10-15-1 |
| <b>Group 20—Lubrication</b>                |         |
| Before Lubrication .....                   | 10-20-1 |
| Extreme Pressure Grease .....              | 10-20-1 |
| Gear Oil .....                             | 10-20-2 |
| Twine Wrap System .....                    | 10-20-2 |
| Alternative and Synthetic Lubricants ..... | 10-20-3 |

### HANDLE FLUIDS SAFELY—AVOID FIRES

When you work around fuel, do not smoke or work near heaters or other fire hazards.

Store flammable fluids away from fire hazards. Do not incinerate or puncture pressurized containers.

Make sure machine is clean of trash, grease, and debris.

Do not store oily rags; they can ignite and burn spontaneously.



DX,FLAME -19-04JUN90

10  
05  
-JUN-23AUG88  
TS227

### PREPARE FOR EMERGENCIES

Be prepared if a fire starts.

Keep a first aid kit and fire extinguisher handy.

Keep emergency numbers for doctors, ambulance service, hospital, and fire department near your telephone.

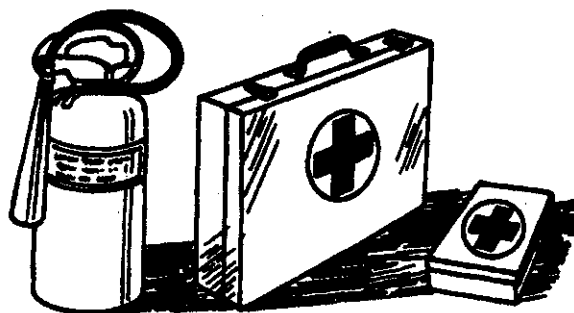

DX,FIRE2 -19-03MAR93

-JUN-23AUG88  
TS291

### AVOID HIGH-PRESSURE FLUIDS

Escaping fluid under pressure can penetrate the skin causing serious injury.

Avoid the hazard by relieving pressure before disconnecting hydraulic or other lines. Tighten all connections before applying pressure.

Search for leaks with a piece of cardboard. Protect hands and body from high pressure fluids.

If an accident occurs, see a doctor immediately. Any fluid injected into the skin must be surgically removed within a few hours or gangrene may result. Doctors unfamiliar with this type of injury should reference a knowledgeable medical source. Such information is available from Deere & Company Medical Department in Moline, Illinois, U.S.A.

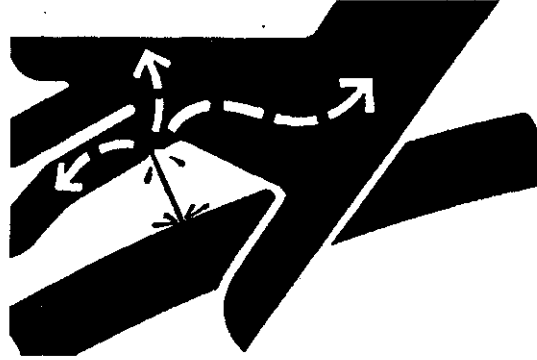

X9811 -JUN-23AUG88

DX,FLUID -19-03MAR93

### SUPPORT MACHINE PROPERLY

Always lower the attachment or implement to the ground before you work on the machine. If you must work on a lifted machine or attachment, securely support the machine or attachment.

Do not support the machine on cinder blocks, hollow tiles, or props that may crumble under continuous load. Do not work under a machine that is supported solely by a jack. Follow recommended procedures in this manual.

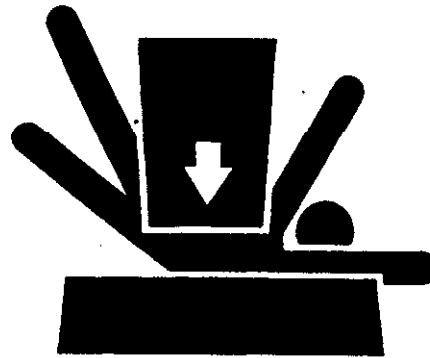

TS229 -JUN-23AUG88

DX,LOWER -19-04JUN90

### WEAR PROTECTIVE CLOTHING

Wear close fitting clothing and safety equipment appropriate to the job.

Prolonged exposure to loud noise can cause impairment or loss of hearing.

Wear a suitable hearing protective device such as earmuffs or earplugs to protect against objectionable or uncomfortable loud noises.

Operating equipment safely requires the full attention of the operator. Do not wear radio or music headphones while operating machine.

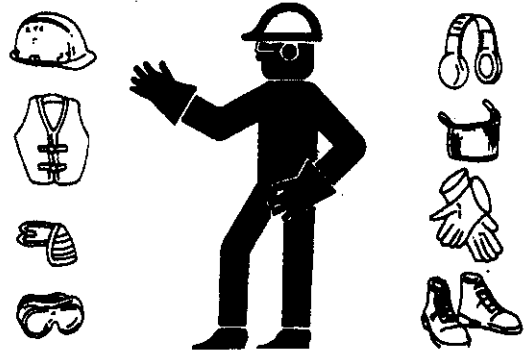

DX,WEAR -19-10SEP90

3375  
-JUN-23AUG88  
TS206

### SERVICE MACHINES SAFELY

Tie long hair behind your head. Do not wear a necktie, scarf, loose clothing, or necklace when you work near machine tools or moving parts. If these items were to get caught, severe injury could result.

Remove rings and other jewelry to prevent electrical shorts and entanglement in moving parts.

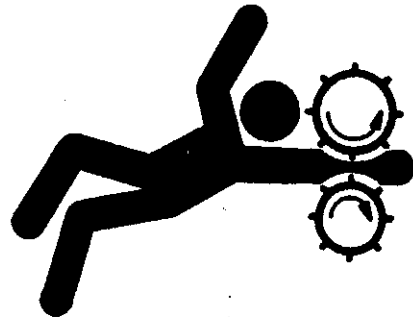

DX,LOOSE -19-04JUN90

-JUN-23AUG88  
TS228

### WORK IN VENTILATED AREA

Engine exhaust fumes can cause sickness or death. If it is necessary to run an engine in an enclosed area, remove the exhaust fumes from the area with an exhaust pipe extension.

If you do not have an exhaust pipe extension, open the doors and get outside air into the area.

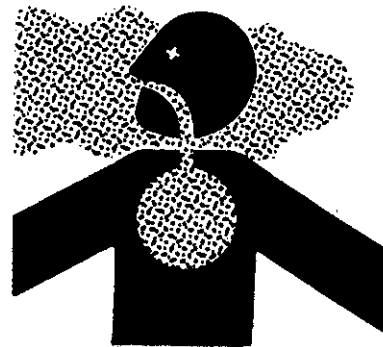

DX,AIR -19-04JUN90

-JUN-23AUG88  
TS220

### ILLUMINATE WORK AREA SAFELY

10  
05  
4

Illuminate your work area adequately but safely. Use a portable safety light for working inside or under the machine. Make sure the bulb is enclosed by a wire cage. The hot filament of an accidentally broken bulb can ignite spilled fuel or oil.



DX,LIGHT -19-04JUN90

TS223 -JUN-23AUG88

### REPLACE SAFETY SIGNS

Replace missing or damaged safety signs. See the machine operator's manual for correct safety sign placement.

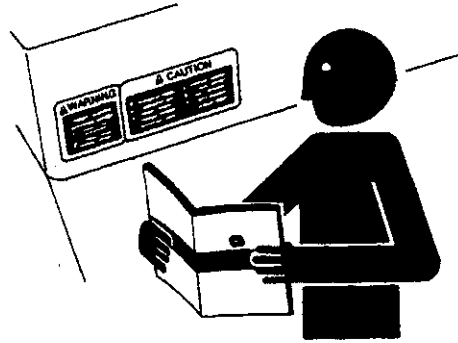

DX,SIGNS1 -19-04JUN90

TS201 -JUN-23AUG88

### USE PROPER LIFTING EQUIPMENT

Lifting heavy components incorrectly can cause severe injury or machine damage.

Follow recommended procedure for removal and installation of components in the manual.

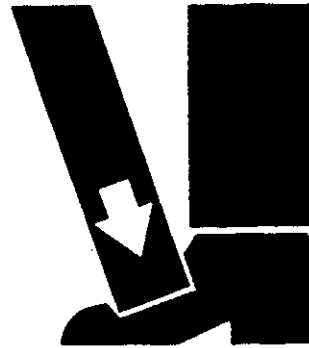

DX,LIFT -19-04JUN90

TS226 -JUN-23AUG88

**SPECIFICATIONS**

| Item  | Measurement   | Specification                               |
|---|---------------|---|
| Shear Bolt (335-375-385)<br>1/4 x 2 in. Grade 8 | Torque        | 18 N·m (13 lb-ft)                           |
| Drive Slip Clutch (435-535):                    |               |   |
| 540 RPM   | Spring Length | 35 mm (1-3/8 in.) from end coil-to-end coil |
| 1000 RPM  | Spring Length | 41 mm (1-5/8 in.) from end coil-to-end coil |

EX.1472.2015,A -19-11MAR93

**SHEAR BOLT REPLACEMENT**  
**(335—375—385)**

When replacing shear bolt, use only a 1/4 x 2-in., grade 8 cap screw and lock nut (A).

**IMPORTANT: Tighten lock nut (A) to 18 N·m (13 lb-ft).**

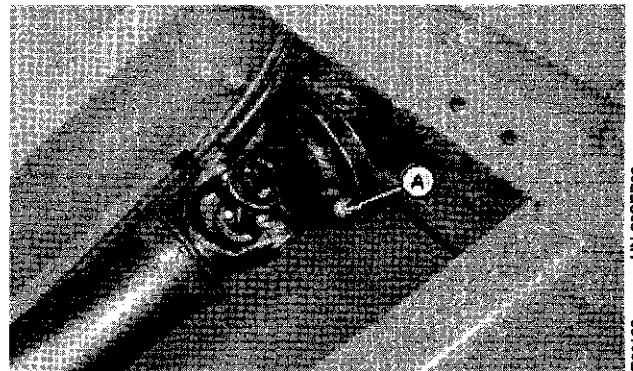

EX.1472.2015,B -19-11MAR93

20  
15

E26163 -UN-20SEP98



**USE CORRECT SHEAR BOLT  
(335—375—385)**

Use shear bolts specified. Shank (A) of shear bolt must extend through shear plane (B).

*NOTE: Use of shorter bolts than those specified will place threads in shear plane resulting in bolts being sheared at lower values, and more often.*

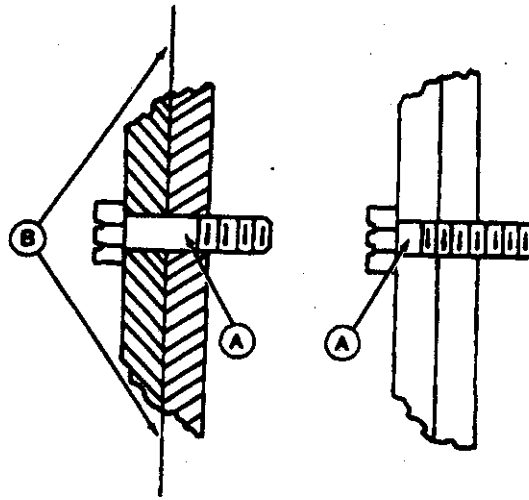

Correct

Wrong

EX,1472,2015,C -19-11MAR93

E27750 -19-07APP89

20  
15  
2

**DISASSEMBLE DRIVELINE SHEAR BOLT  
HUB (335—375—385)**

1. Remove plug (A).
2. Fill opening with solvent.

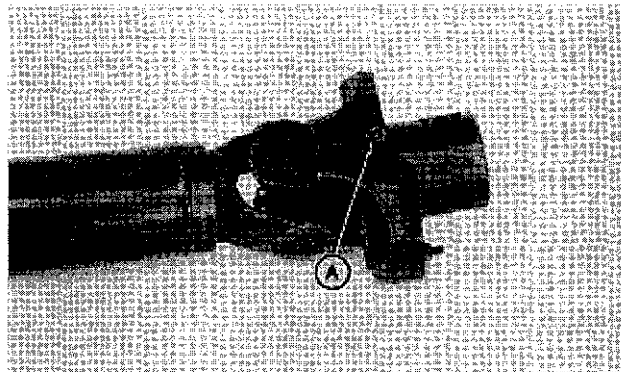

EX,1472,2015,D -19-11MAR93

E27753 -JUN-20SEP88

3. Remove shear bolt (A).
4. Turn driveline over and rotate hub (B).
5. Thirty-one ball bearings (C) should come out.
6. Remove hub (B).

- A—Shear Bolt
- B—Hub
- C—Ball Bearings
- D—Plug

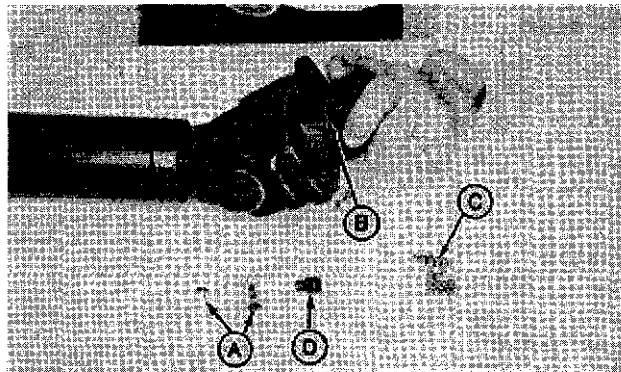

EX,1472,2015,E -19-21JUL89

E27754 -JUN-20SEP88

## INSPECT DRIVELINE

Check hub (A) for galling and excessive wear.

Check bearings and guides for breakage.

Check bearing and cross assemblies for looseness and wear.

Clean all parts before assembling.

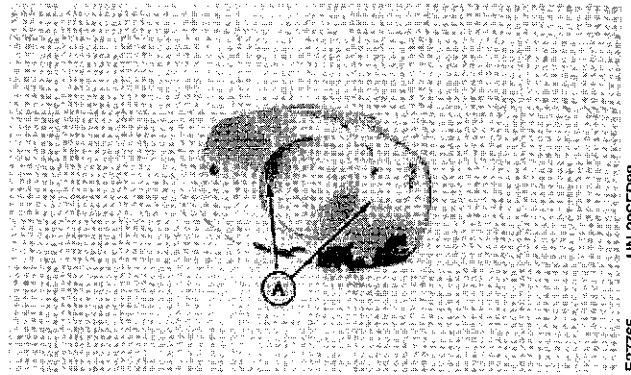

EX,1472,2015,F -19-11MAR93

E27765 -UN-20SEP88 20 15 3

## ADJUST DRIVE SLIP CLUTCH (435—535)

Check slip clutch spring length if excessive slipping occurs during operation or if it has been disassembled.

For 540 rpm, the clutch is properly adjusted when dimension (A) is 35 mm (1-3/8 in.) from end coil to end coil.

For 1000 rpm, the clutch is properly adjusted when dimension (A) is 41 mm (1-5/8 in.) from end coil to end coil.

**IMPORTANT:** The slip clutch has been designed to furnish protection to the drive train; overtightening will decrease this protection.

To adjust slip clutch:

1. Shut off tractor engine.
2. Loosen jam nut (B).
3. Turn spring adjusting bolt (C) until proper spring dimension (A) is attained.
4. Tighten jam nut (B).

**NOTE:** For proper operation pressure plate warpage cannot exceed 1.5 mm (1/16 in.).

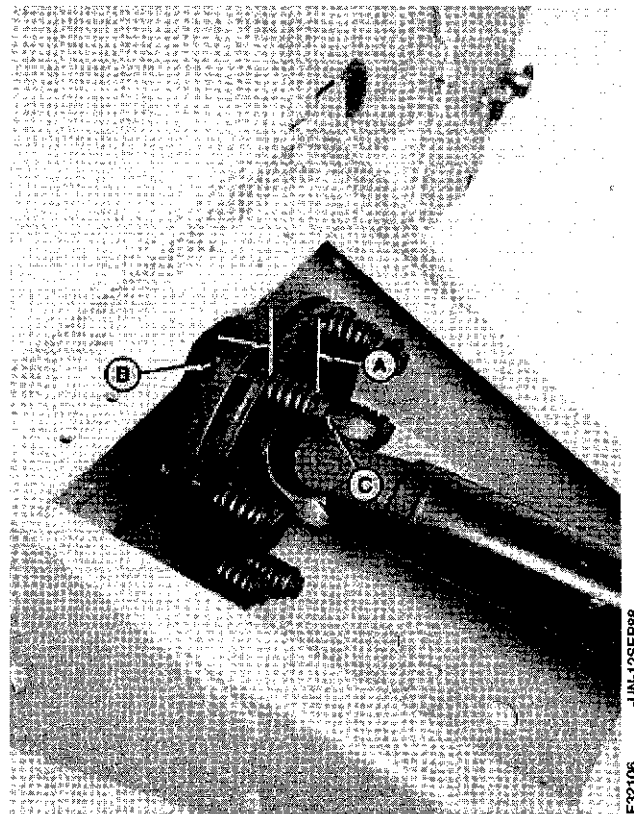

- A—35 mm (1-3/8 in.) 540 rpm  
41 mm (1-5/8 in.) 1000 rpm
- B—Jam Nut
- C—Adjusting Bolt

E32106 -UN-12SEP88

EX,1472,2015,G -19-06NOV95

**SPECIFICATIONS**

| Item       | Measurement | Specification     |
|------------|-------------|-------------------|
| Shear Bolt | Torque      | 18 N·m (13 lb-ft) |

EX,1472,2020,U -19-11MAR93

20  
20  
1

**REMOVE CONSTANT VELOCITY DRIVELINE  
(435—535)**

1. Remove two lock nuts and cap screws (A).

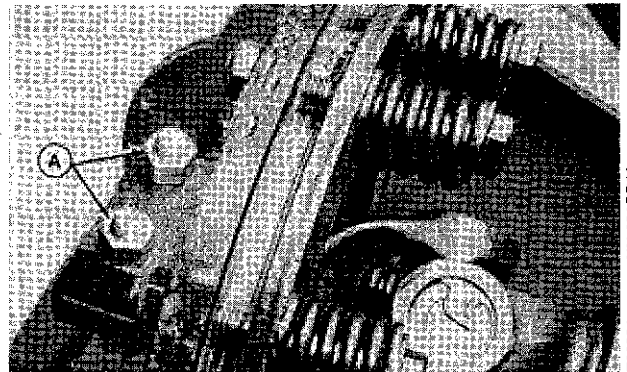

-UN-20APR89  
E32804

EX,1472,2020,A -19-11MAR93

**REMOVE CONSTANT VELOCITY DRIVELINE  
(335—375—385)**

1. Remove lock nut, cap screw (A) and driveline (B).
2. Separate the two halves for ease in handling.

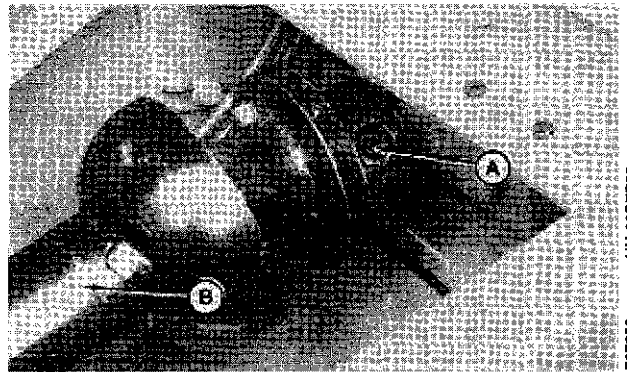

-UN-20SEP88  
E27752

EX,1472,2020,B -19-11MAR93

**DISASSEMBLE CONSTANT VELOCITY  
DRIVELINE**

1. Remove front half of PTO from rear half.
2. Using a screwdriver, push inward to remove snap ring (A). Remove shield assembly (B). Wipe grease from assembly.

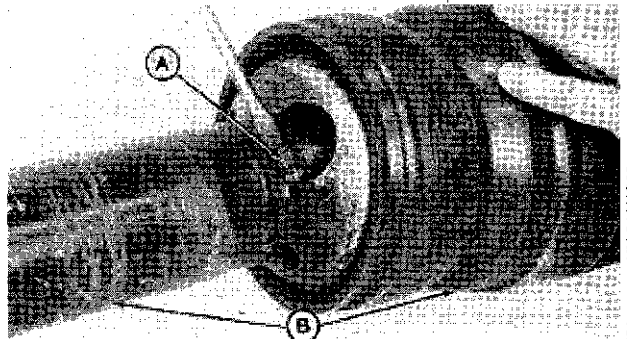

-UN-21AUG89  
E33521

EX,1472,2020,C -19-11MAR93

PTO Hookup/Remove and Replace Front and/or Rear Cross Constant Velocity PTO

3. Remove four snap rings (A).

4. Remove cups (B) from center housing (E). Separate and yoke with cross from center housing.

- A—Snap Ring
- B—Cups
- C—Cross
- D—Yoke
- E—Center Housing

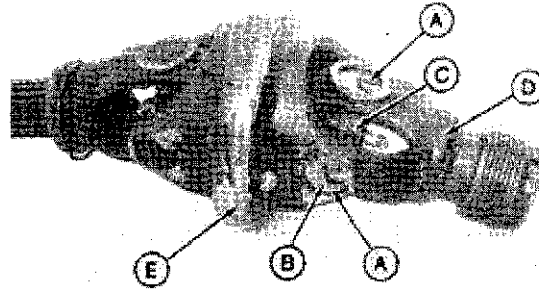

EX,1472,2020,D -19-11AUG89

E33522 -JUN-21AUG89

5. Remove cups (A) and cross (B) from end yoke. Clean center housing and end yoke.

6. Inspect parts (pin and center plate in center housing, cross, and yoke bores) for wear and galling.

7. Check for free operation of slide-lock collar and pawls. Collar and pawls must be free to move.

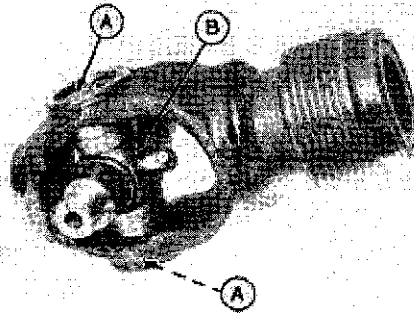

EX,1472,2020,E -19-11AUG89

E33523 -JUN-21AUG89

8. Install lubrication fitting (A) in new cross and align with long leg of cross.

9. Install short legs of cross cups and snap ring in end yoke with fitting pointing away from centering ball (B).

**NOTE:** When installing end yoke in center housing, flat side of ball **MUST** be toward center disk.

10. Pin (C) must be inserted in end yoke ball and flat side of ball (B) must be toward the center disk when installing end yoke in center housing.

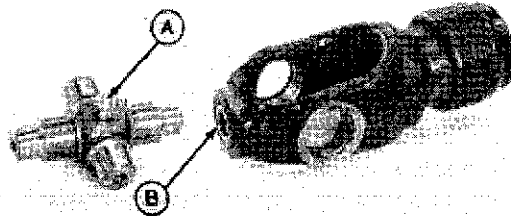

E33524 -JUN-21AUG89

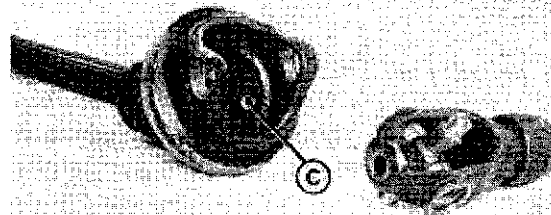

E33525 -JUN-21AUG89

EX,1472,2020,F -19-06NOV95



**Download the full PDF manual instantly.**

**Our customer service e-mail:**

**[aservicemanualpdf@yahoo.com](mailto:aservicemanualpdf@yahoo.com)**