

# 450 and 780 Hydra-Push Manure Spreaders



JOHN DEERE

## TECHNICAL MANUAL 450 and 780 Hydra-Push Manure Spreaders

TM1318 (01JUN87) English

**TM1318 (01JUN87)**

LITHO IN U.S.A. (REVISED)  
ENGLISH



# 450 AND 780 HYDRA-PUSH™ MANURE SPREADERS TECHNICAL MANUAL TM-1318 (JUNE-87)

## SECTION AND GROUP CONTENTS

### SECTION 10—GENERAL INFORMATION

- Group 05—Introduction And Safety
- Group 10—General Specifications
- Group 15—Lubricants
- Group 20—Serial Numbers

### SECTION 20—BEATER DRIVE

- Group 05—General Information
- Group 10—Operational Checks
- Group 15—Driveline Repair
- Group 20—Clutch Repair
- Group 25—Input Shaft Repair
- Group 30—Drive Sprockets and Chain Repair
- Group 35—Beater Side Shaft Repair
- Group 40—Gear Case Repair
- Group 45—Main Beater Repair
- Group 50—Upper Beater Repair

### SECTION 30—HYDRAULICS

- Group 05—General Information
- Group 10—Testing
- Group 15—Secondary Cylinder Repair
- Group 20—Primary Cylinder Repair
- Group 25—Endgate Cylinder Repair
- Group 30—Closed-Center Hydraulic Control Valve  
Repair
- Group 35—Open-Center Hydraulic Control Valve  
Repair

### SECTION 40—MISCELLANEOUS

- Group 05—Wooden Guides and Wiper Seals Repair
- Group 10—Wheels and Axle Repair
- Group 15—Moving Panel Repair
- Group 20—Sliding Floor Repair
- Group 25—Endgate Repair
- Group 30—FRP Panel Repair

*All information, illustrations and specifications contained in this technical manual are based on the latest information available at the time of publication. The right is reserved to make changes at any time without notice.*

COPYRIGHT® 1987  
DEERE & COMPANY  
Moline, Illinois  
All rights reserved  
A JOHN DEERE ILLUSTRATION

W02;;0000 -A 090687

# Section 10 GENERAL INFORMATION

## CONTENTS

	Page
<b>GROUP 05—Introduction And Safety</b>	
Introduction . . . . .	10-05-2
Safety . . . . .	10-05-3
<b>GROUP 10—General Specifications</b>	
Dimensions	
450 Spreader . . . . .	10-10-1
780 Spreader . . . . .	10-10-2
Specifications—450 And 780 Spreader . . . . .	10-10-3
Bolt Torque Chart . . . . .	10-10-5
Tightening O-Ring Fittings . . . . .	10-10-6
Tightening Flare Type Tube Fittings . . . . .	10-10-6
Tightening Pipe Thread Fittings . . . . .	10-10-7
Tightening Flare Type Hose Fittings . . . . .	10-10-7
<b>GROUP 15—Lubricants . . . . .</b>	<b>10-15-1</b>
<b>GROUP 20—Serial Numbers . . . . .</b>	<b>10-20-1</b>

*John Deere 450 Hydra-Push™ Manure Spreader (1980-)*

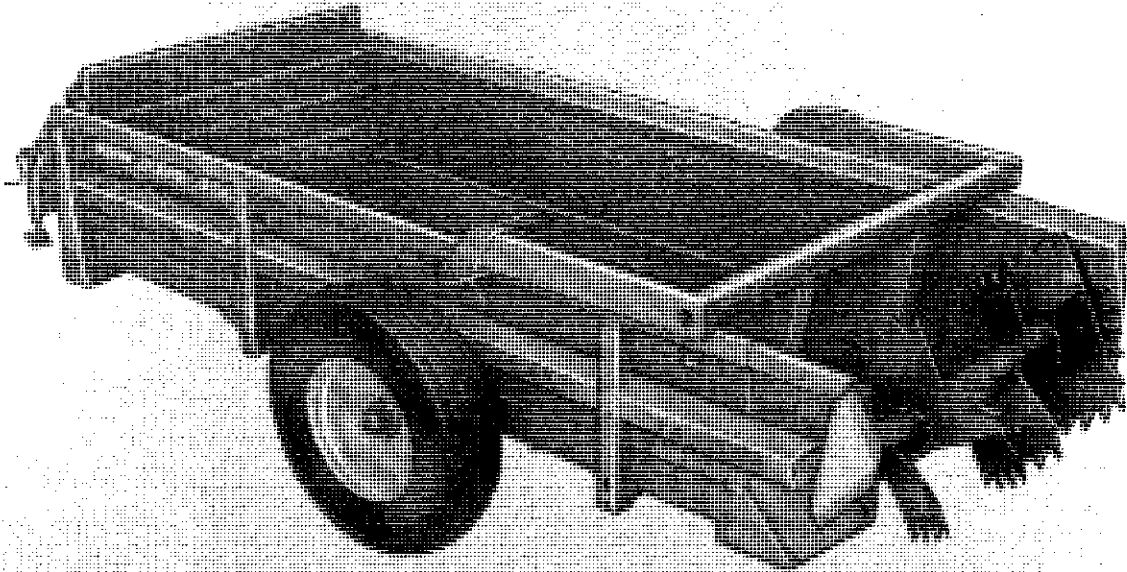

*John Deere 780 Hydra-Push™ Manure Spreader (1984-)*

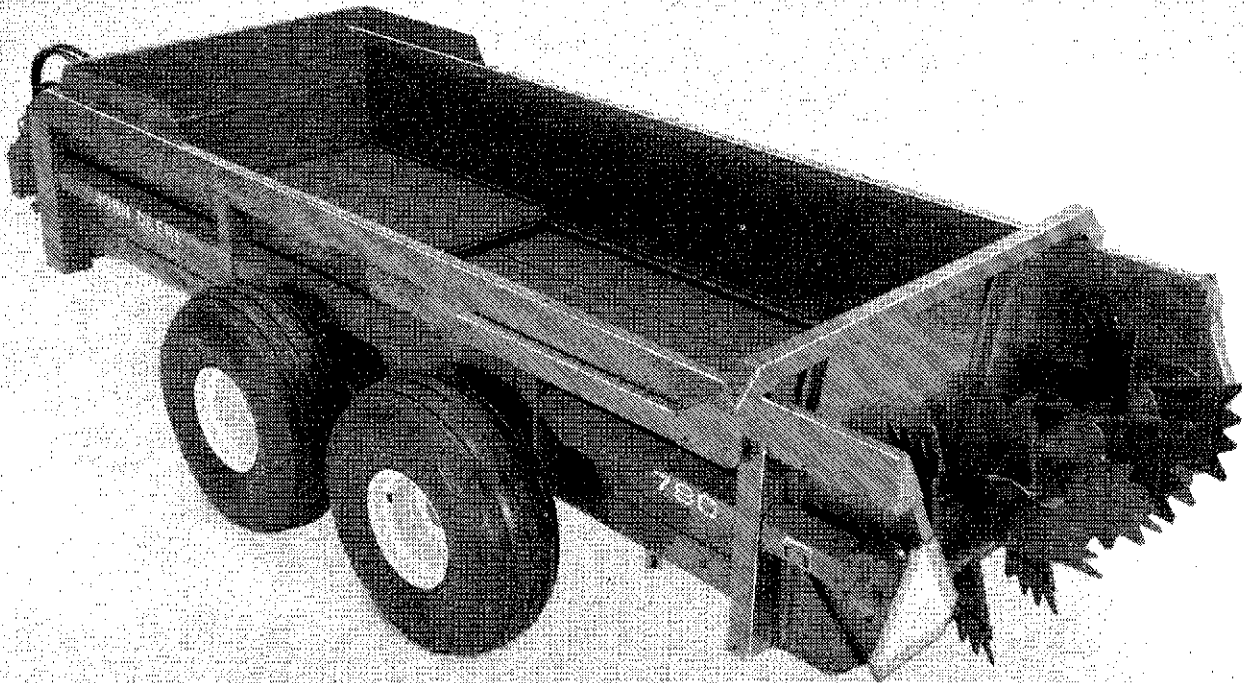

8DA;W12517 5EA;W9965 W02;;1005 -A 120587

## INTRODUCTION

This technical manual is part of a twin concept of service.

### FOS Manuals—reference

### Technical Manuals—machine service

The two kinds of manuals work as a team to give you both the general background and technical details of shop service.

*Fundamentals of Service (FOS) Manuals* cover basic theory of operation, fundamentals of troubleshooting, general maintenance, and basic types of failures and their causes. FOS Manuals are for training new personnel and for reference by experienced technicians.

*Technical Manuals* are concise service guides for specific machines. Technical manuals are on-the-job guides containing only the vital information needed by an experienced service technician.

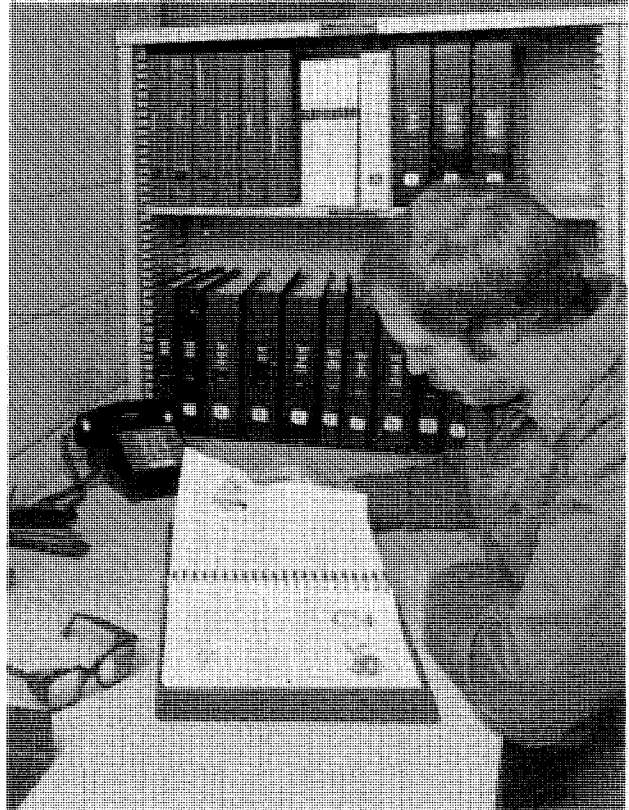

AB6;RW5559 053;INTR01 071085

## FEATURES OF THIS TECHNICAL MANUAL

John Deere ILLUSTRATION format emphasizing illustrations and concise instructions in easy-to-use modules.

Emphasis on diagnosis, analysis, and testing so you can understand the problem and correct it.

Diagnostic information presented with the most logical and easiest to isolate problems first to help you identify the majority of routine failures quickly.

Step-by-step instructions for teardown and assembly.

Summary listing at the beginning of each group of all applicable specifications, wear tolerances, torque values, essential tools, and materials needed to do the job.

An emphasis throughout on safety—so you do the job right without getting hurt.

This technical manual was planned and written for you—an experienced service technician. Keep it in a permanent binder in the shop where it is handy. Refer to it when you need to know correct service procedures or specifications.

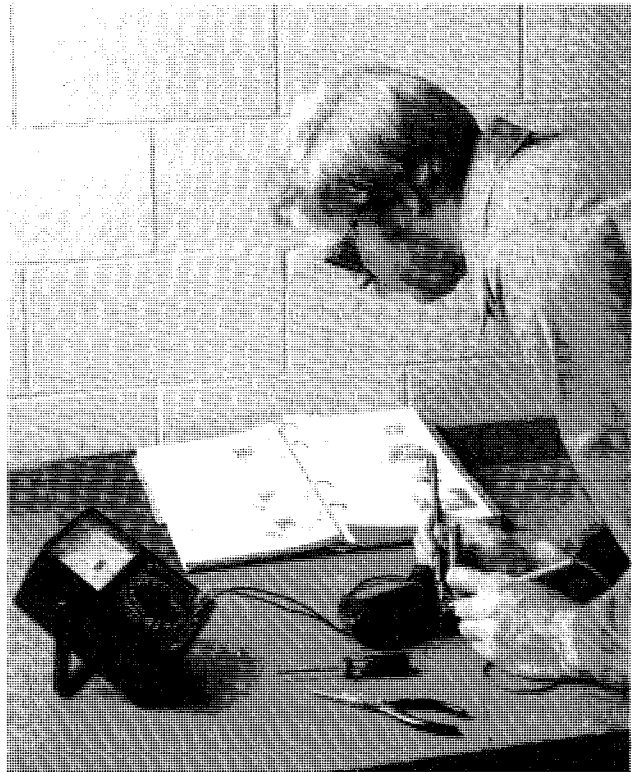

AB6;RW5560 053;INTR03 071085

## SAFETY AND YOU

This is the safety-alert symbol. When you see this symbol on the machine or in this manual, be alert to the potential for personal injury.



AB6;T81389 053;TMSAFE 071085

## PREPARE FOR EMERGENCIES

Be prepared if a fire starts.

Keep a first aid kit and fire extinguishers handy.

Keep emergency numbers for doctors, ambulance service, hospital, and fire department near your telephone.



AB6;TS186 053;FIRE2 080785

## STAY CLEAR OF PTO

Entanglement in rotating driveline can cause serious injury or death.

Keep tractor master shield and driveline shields in place at all times except for special applications as directed in the implement operator's manual.

Wear fairly tight fitting clothing. Stop the engine and be sure PTO driveline is stopped before making adjustments, connections, or cleaning out PTO driven equipment.



AB6;TS198 053;PTO 280186

## WEAR PROTECTIVE CLOTHING

Wear fairly tight clothing. . . . . and safety equipment.



AB6;TS184 053;WEAR2 080785

## PROTECT AGAINST NOISE

Prolonged exposure to loud noise can cause impairment or loss of hearing.

Wear a suitable hearing protective device such as earmuffs (A) or earplugs (B) to protect against objectionable or uncomfortable loud noises.

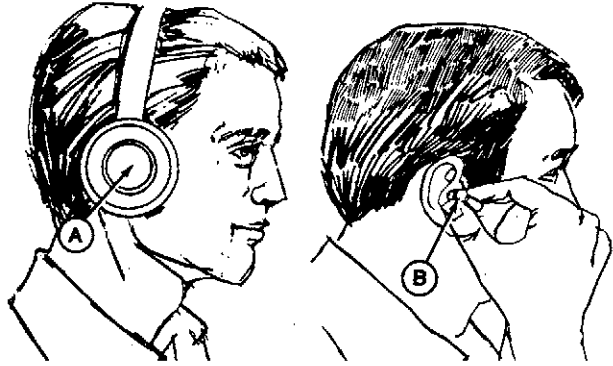

AB6;X7662 053;NOISE 270886

## AVOID HIGH-PRESSURE FLUIDS

Escaping fluid under pressure can penetrate the skin causing serious injury. Relieve pressure before disconnecting hydraulic or other lines. Tighten all connections before applying pressure. Keep hands and body away from pinholes and nozzles which eject fluids under high pressure. Use a piece of cardboard or paper to search for leaks.

If ANY fluid is injected into the skin, it must be surgically removed within a few hours by a doctor familiar with this type injury or gangrene may result.

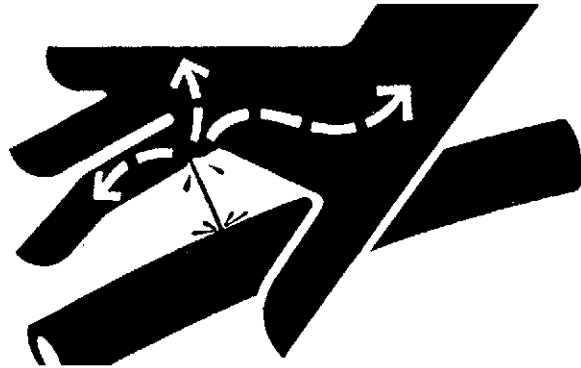

AB6;X9811 053;FLUID. 290186

## USE A SAFETY CHAIN

A safety chain will help control drawn equipment (B) should it accidentally separate from the drawbar (A) while transporting. Using the appropriate adapter parts, attach the chain to the tractor drawbar support or other specified anchor location. Provide only enough slack in the chain to permit turning. See your John Deere dealer for a chain with a strength rating equal to or greater than the gross weight of the towed machine.

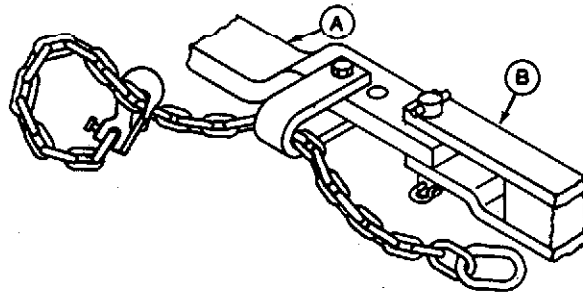

AB6;TS163 053;CHAIN. 290186

## TRANSPORT SPREADER SAFELY

To reduce chance of personal injury, always tow spreader slowly enough to maintain control.

Use extra care when towing spreader at transport speeds.

Do not tow a loaded spreader that weighs more than twice the tractor weight.

To assure adequate braking performance and control, tow only with an agricultural tractor. Safe towing speed depends on weight of tractor and weight of towed load. (See Recommended Maximum Towing Speed in Transporting section of Spreader operator's manual.)

Tow only with an agricultural tractor. Refer to Spreader operator's manual for tractor minimum weight. Never exceed 32 km/h (20 mph).

Use accessory lights and devices for warning to operators of other vehicles.

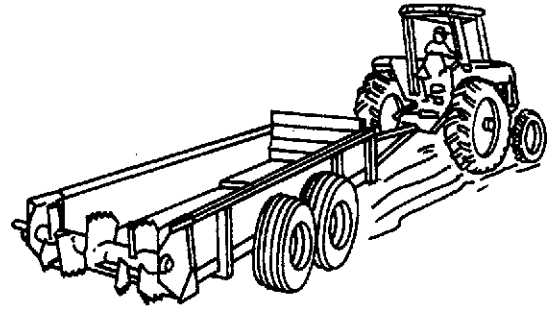

8DA;W13247 W01;;12SY -G 110587

## OPERATE SPREADER SAFELY

Refer to the Spreader operator's manual for operating instructions.

Do not exceed load capacity of the spreader. (See Transporting section of Spreader operator's manual.)

Never enter a spreader while in operation.

Reduce tractor ground speed when turning or traveling on rough terrain.

Avoid traveling over loose fill, rocks, ditches or holes.

When working on inclines or slopes, travel uphill or downhill. Keep tractor in gear when traveling downhill.

Drive slowly through gates and doors.

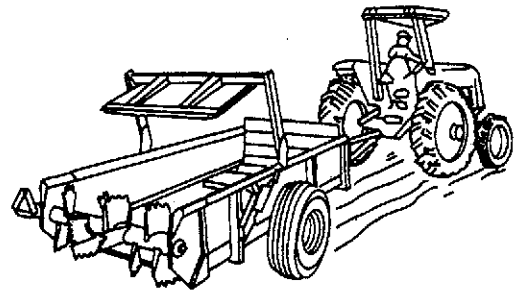

8DA;W12404 W01;;11SY -D 110587



## SERVICE SPREADER SAFELY

Help prevent personal injury caused by unexpected movement of the machine. If spreader is connected to tractor, disengage PTO, engage parking brake and/or place transmission in "PARK", shut off engine, and remove key. If spreader is detached, block wheels and use safety stands.

Replace all shields after lubricating or servicing.

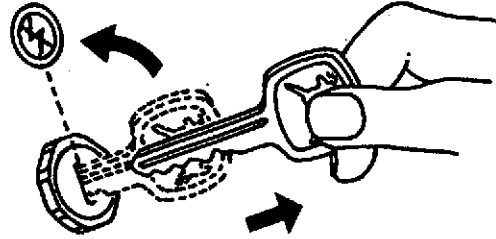

8DA;W9765 W01;;125Y -K 050387

## KEEP SERVICE AREA CLEAN

Keep the service area clean and dry; wet or oily floors are slippery. Wet spots can be dangerous when working with electrical equipment.

Be sure all electrical outlets and tools are properly grounded.

Use adequate light for the job at hand.



5EA;W9966 W02;;1005 -E 150187

## SERVICE TIRES SAFELY

Failure to follow proper procedures when mounting a tire on a wheel or rim can produce an explosion which may result in serious injury or death. Do not attempt to mount a tire unless you have the proper equipment and experience to perform the job. Have it done by your John Deere dealer or a qualified tire repair service.

When sealing tire beads on rims, never exceed 35 psi (241 kPa) (2.4 bar) or maximum inflation pressures specified by tire manufacturers for mounting tires. Inflation beyond this maximum pressure may break the bead, or even the rim, with dangerous explosive force. If both beads are not seated when the maximum recommended pressure is reached, deflate, reposition tire, relubricate bead and reinflate.

- A—Use a Safety Cage if Available.
- B—Do Not Stand Over Tire. Use a Clip-on Chuck and Extension Hose.

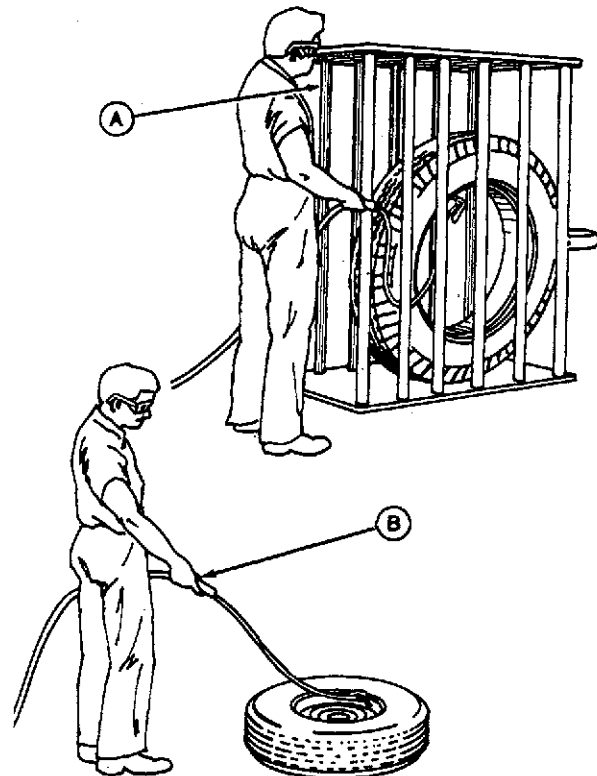

AB6;TS123 053;TIRE 160486

**DIMENSIONS-450 SPREADER**

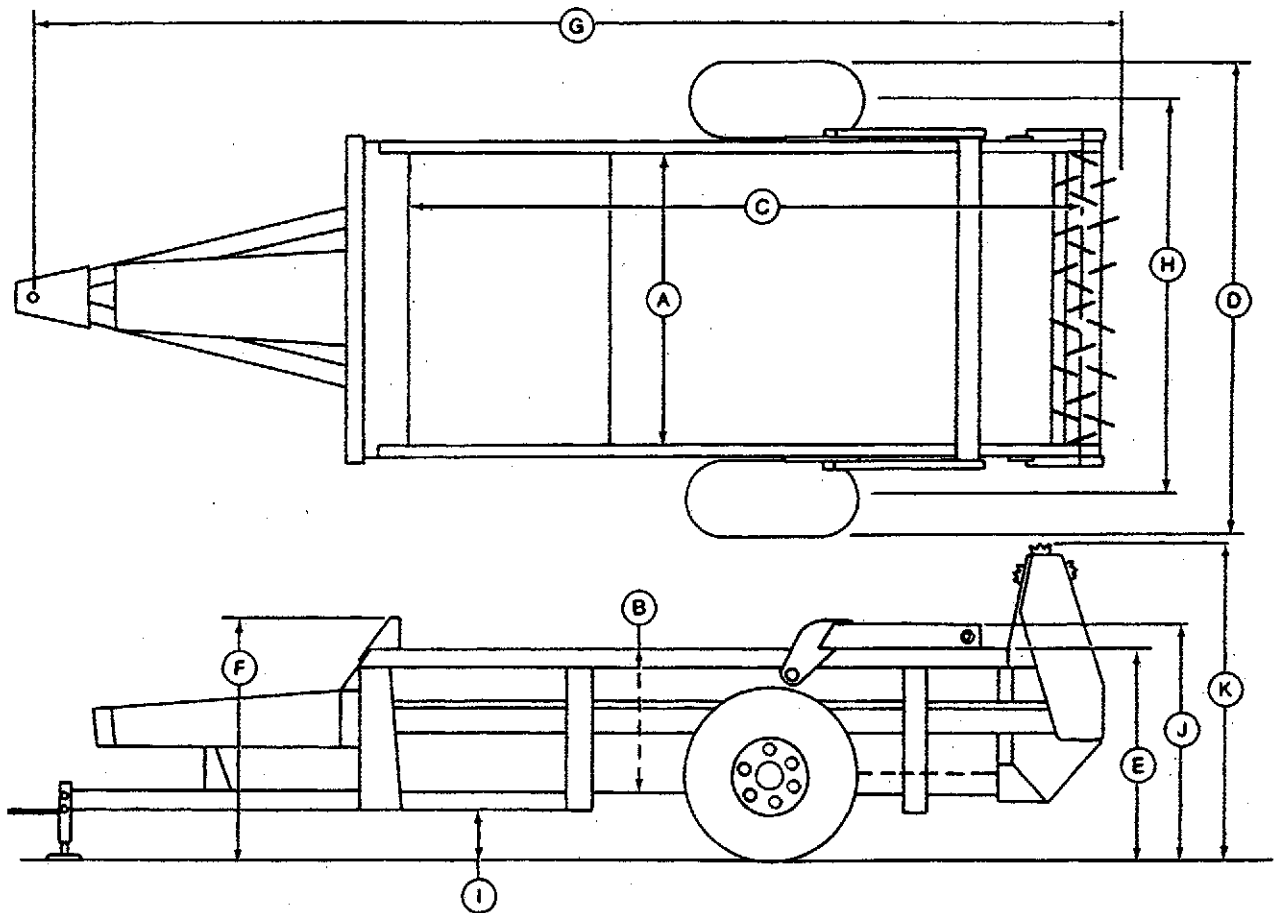

- A—1570 mm (61.8 in.)
- B—698 mm (27.5 in.)
- C—3870 mm (152.4 in.)
- D—2400 mm (94.5 in.) \*
- E—1165 mm (45.9 in.) \*
- F—1320 mm (52.0 in.) \*

- G—5870 mm (231.1 in.)
- H—2050 mm (80.7 in.)
- I—350 mm (13.8 in.) \*
- J—1300 mm (51.2 in.) \*
- K—1679 mm (66.1 in.) \*

\* For spreader equipped with 10.00 x 20 recapped truck tires.

Specifications and design subject to change without notice

8DA;W12518 W02;1010 -A 200487

**DIMENSIONS-780 SPREADER**

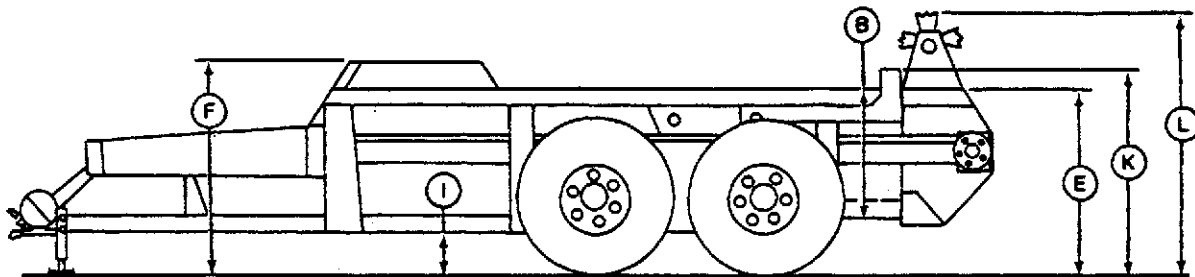
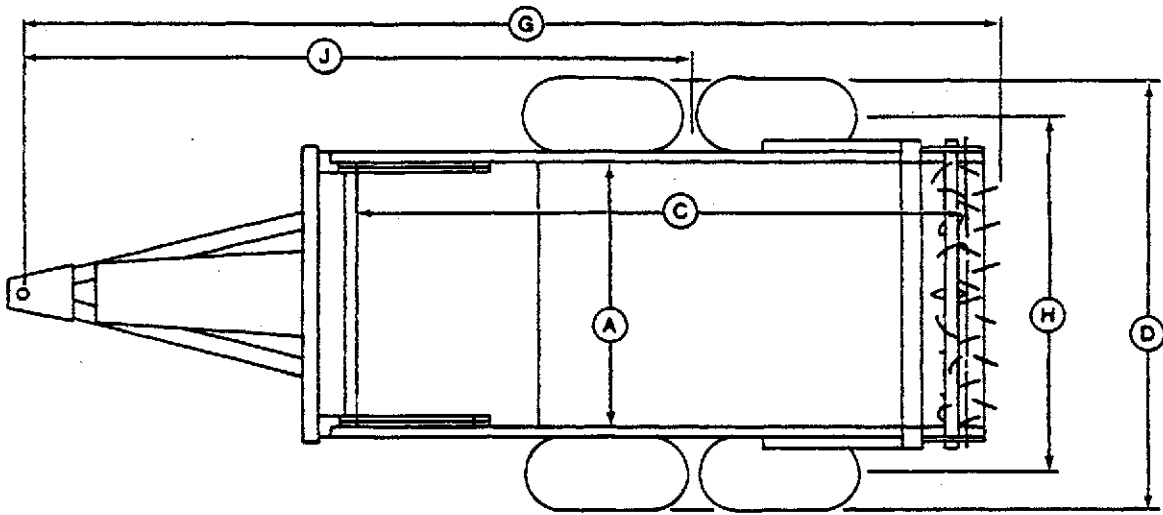

A—1810 mm (71.3 in.)  
 B—770 mm (30.3 in.)  
 C—4900 mm (192.9 in.) \*  
 D—2732 mm (107.6 in.) \*  
 E—1311 mm (51.6 in.) \*  
 F—1459 mm (57.4 in.) \*

G—7420 mm (292.1 in.)  
 H—2450 mm (96.5 in.)  
 I—280 mm (11.0 in.) \*  
 J—4850 mm (191.0 in.)  
 K—1422 mm (56.0 in.) \*  
 L—1814 mm (71.4 in.) \*

\* For spreader equipped with 10.00 x 20 recapped truck tires.

Specifications and design subject to change without notice

**SPECIFICATIONS-450 AND 780 SPREADER**

<b>Spreader Model</b>	<b>450</b>	<b>780</b>
Tractor Size (Minimum)	45 kW (60 hp) PTO	76 kW (100 hp) PTO
Weight		
Spreader Less Wheels, Tires, Endgate	1079 kg (2379 lb)	1924 kg (4242 lb)
8 x 20 Wheels	46 kg (102 lb)	92 kg (203 lb)
Wheels and 10.00 x 20 Recapped Truck Tires	127 kg (280 lb)	254 kg (560 lb)
Wheels and 16.5L x 16.1 Tires	127 kg (280 lb)	262 kg (578 lb)
Hydraulic Endgate	123 kg (272 lb)	212 kg (462 lb)
Upper Beater	70 kg (154 lb)	100 kg (220 lb)
Endpan	64 kg (142 lb)	63 kg (139 lb)
Load Capacity	5897 kg (13000 lb)	9526 kg (21000 lb)
Volume Capacity		
Struck Level	4.0 m <sup>3</sup> (141 cu. ft.)	6.3 m <sup>3</sup> (222 cu. ft.)
Heaped Load (Single Beater)	6.1 m <sup>3</sup> (217 cu. ft.)	9.4 m <sup>3</sup> (332 cu. ft.)
(Upper Beater)	8.1 m <sup>3</sup> (286 cu. ft.)	12.0 m <sup>3</sup> (424 cu. ft.)
Beater Speed		
Upper	255 rpm	294 rpm
Lower	356 rpm	337 rpm
Unloading Speed	0-4.6 m/min (0-15 ft/min) Infinitely Variable	0-5 m/min (0-16 ft/min) Infinitely Variable
Driveline	Shielded 540 rpm Shielded 1000 rpm	Powr-Gard 540 rpm Shielded 1000 rpm (With Constant Velocity Front Joint)
Attachments	Control For Fender or Rops Mount	Control For Fender or Rops Mount
	Open Center Valve With Control	Open Center Valve With Control
	Upper Beater Endgate Endpan Warning Light Kit Splash Guards Cold Weather Conditions Kit	Upper Beater Endgate Endpan Warning Light Kit Drawbar Support Cold Weather Conditions Kit

*Specifications and design subject to change without notice*

W02;1010 -C 110587

*General Specifications/Specifications-450 And 780 Spreader*

Driveline	Shielded 540 rpm Shielded 1000 rpm	Powr-Gard 540 rpm Shielded 1000 rpm (With Constant Velocity Front Joint)
Attachments	Control For Fender or Rops Mount Open Center Valve With Control Upper Beater Endgate Endpan Warning Light Kit Splash Guards Cold Weather Conditions Kit	Control For Fender or Rops Mount Open Center Valve With Control Upper Beater Endgate Endpan Warning Light Kit Drawbar Support Cold Weather Conditions Kit

*Specifications and design subject to change without notice*

W02;;1010 -AA 150187

### CHECKING BOLT TORQUE

The tables shown below give correct torque values for various bolts and cap screws. Tighten all bolts to the torques specified in chart unless otherwise noted. Check tightness of bolts periodically, using bolt torque chart as a guide. Replace hardware with the same strength bolt.

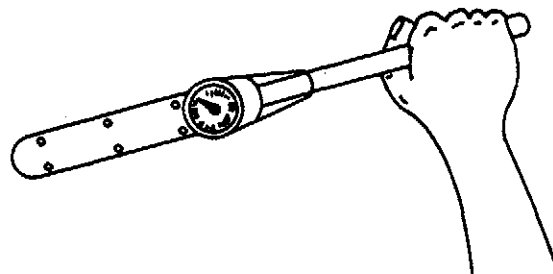

### ENGLISH TORQUE SPECIFICATIONS

Bolt Diameter A	Bolt Torque*					
	SAE 2		SAE 5		SAE 8	
	N.m (lb-ft)		N.m (lb-ft)		N.m (lb-ft)	
1/4 in.	8	(6)	12	(9)	16	(12)
5/16 in.	13	(10)	24	(18)	34	(25)
3/8 in.	27	(20)	41	(30)	61	(45)
7/16 in.	41	(30)	63	(50)	95	(70)
1/2 in.	61	(45)	101	(75)	149	(110)
9/16 in.	95	(70)	150	(110)	210	(155)
5/8 in.	128	(95)	210	(155)	290	(215)
3/4 in.	225	(165)	365	(270)	520	(385)
7/8 in.	230	(170)	590	(435)	840	(620)
1 in.	345	(255)	895	(660)	1260	(930)

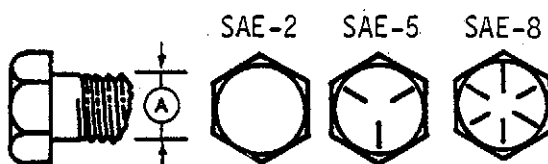

### METRIC TORQUE SPECIFICATIONS

Bolt Diameter A	Bolt Torque*			
	N.m	8.8 (lb-ft)	N.m	10.9 (lb-ft)
M3	0.5	(0.4)	1.8	(1.3)
M4	3	(2.2)	4.5	(3.3)
M5	6	(4)	9	(7)
M6	10	(7)	15	(11)
M8	25	(18)	35	(26)
M10	50	(37)	70	(52)
M12	90	(66)	125	(92)
M14	140	(103)	200	(148)
M16	225	(166)	310	(229)
M20	435	(321)	610	(450)
M24	750	(553)	1050	(774)
M30	1495	(1103)	2100	(1550)
M36	2600	(1917)	3675	(2710)

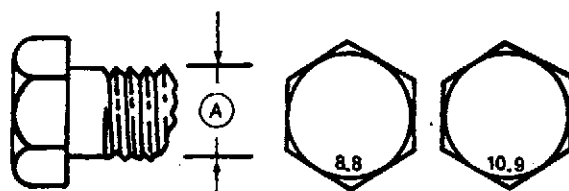

Torque figures are for non-greased or non-oiled threads. When using locking elements, increase torque values by 5%.

\*Torque value for bolts and cap screws are identified by their head markings.

General Specifications/Tightening Flare Type Tube Fittings

**TIGHTENING O-RING FITTINGS\***

	Thread Size (in.)	Nut Size Across Flats (in.)	Torque (N·m)	Value* (lb-ft)	Recommended Turns To Tighten (After Finger Tightening) (Flats)	(Turns)
1. Inspect O-ring and seat for dirt or obvious defects.						
2. On angle fittings, back the lock nut off until washer bottoms out at top of groove.						
3. Hand tighten fitting until backup washer or washer face (if straight fitting) bottoms on face and O-ring is seated.	3/8	1/2	8	6	2	1/3
	7/16	9/16	12	9	2	1/3
	1/2	5/8	16	12	2	1/3
4. Position angle fittings by unscrewing no more than one turn.	9/16	11/16	24	18	2	1/3
	3/4	7/8	46	34	2	1/3
5. Tighten straight fittings to torque shown.	7/8	1	62	46	1-1/2	1/4
6. Tighten angle fittings to torque shown while holding the body of fitting with a wrench.	1-1/16	1-1/4	102	75	1	1/6
	1-3/16	1-3/8	122	90	1	1/6
* The torque values shown are based on lubricated connections as in reassembly.	1-5/16	1-1/2	142	105	3/4	1/8
	1-5/8	1-7/8	190	140	3/4	1/8
	1-7/8	2-1/8	217	160	1/2	1/12

W07;;2SV C. 090686

**TIGHTENING FLARE TYPE TUBE FITTINGS\***

	Tube Size OD (in.)	Nut Size Across Flats (in.)	Torque (N·m)	Value* (lb-ft)	Recommended Turns To Tighten (After Finger Tightening) (Flats)	(Turns)
1. Check flare and flare seat for defects that might cause leakage.						
2. Align tube with fitting before tightening.	3/16	7/16	8	6	1	1/6
	1/4	9/16	12	9	1	1/6
3. Lubricate connection and hand tighten swivel nut until snug.	5/16	5/8	16	12	1	1/6
	3/8	11/16	24	18	1	1/6
4. To prevent twisting the tube(s), use two wrenches. Place one wrench on the connector body and with the second, tighten the swivel nut to the torque shown in this chart.	1/2	7/8	46	34	1	1/6
	5/8	1	62	46	1	1/6
* The torque values shown are based on lubricated connections as in reassembly.	3/4	1-1/4	102	75	3/4	1/8
	7/8	1-3/8	122	90	3/4	1/8

W07;;2SV D. 090686

**TIGHTENING PIPE THREAD FITTINGS**

1. Inspect threads for dirt or defects that may cause leakage.
2. Apply teflon sealant to external threads.
3. Tighten fitting between 25 lb-ft (34 N·m) minimum to 46 lb-ft (62 N·m) maximum torque.

W01;SAS R 040385

**TIGHTENING FLARE TYPE HOSE FITTINGS\***

1. Check flare and flare seat for defects that might cause leakage.
2. Align tube with fitting before tightening.
3. Lubricate connection and hand-tighten swivel nut until snug.
4. To prevent twisting the hose(s), use three wrenches. Place one on the connector body, one on the body of the hose fitting and with the third, tighten the swivel nut to the torque shown in this chart.

\*The torque values shown are based on lubricated connections as in reassembly.

	Thread Size (in.)	Torque Value*		Recommended Turns To Tighten (After Finger Tightening)	
		N·m	(lb-ft)	(Flats)	(Turns)
	3/8	8	6	1	1/6
	7/16	11	8	1	1/6
	1/2	14	10	1	1/6
	9/16	24	18	1	1/6
	3/4	38	28	1	1/6
	7/8	54	40	3/4	1/8
	1-1/16	75	55	3/4	1/8
	1-5/16	92	68	3/4	1/8

W01;SAS N. 110786



## SELECTING GREASE

Depending upon the expected air temperature range during the service interval, use grease as shown on the adjusting temperature chart.

The following greases are recommended:

—John Deere Moly High Temperature/Extreme Pressure Grease

—SAE—Multipurpose High Temperature Grease with Extreme Pressure [EP] Performance with 3 to 5% molybdenum disulfide.

*NOTE: Moly-type grease is recommended, however, if not available, a multipurpose grease is acceptable.*

*The part number for Moly High Temperature/Extreme Pressure grease in 14 oz. tubes is TY6333 for a package of ten.*

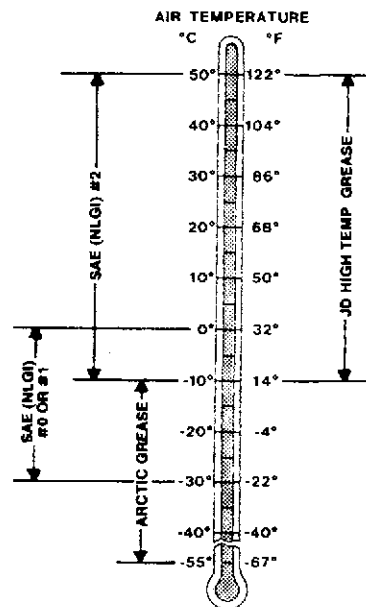

4EA;X9328 W11;;5LB C. 090686

## SELECTING GEAR CASE OIL

Depending upon the expected air temperature range during the drain interval, use oil viscosity shown on the adjoining temperature chart.

John Deere 85W140 API GL-5 gear oil is recommended. If other oils are used, they must be oils meeting the following requirements:

- API Service Classification GL-6
- Military Specification MIL-L-2105B
- Military Specification MIL-L-2105C

At temperatures below  $-35^{\circ}\text{C}$  [ $-31^{\circ}$ ], use arctic oils such as those meeting Military Specifications MIL-G-10324A.

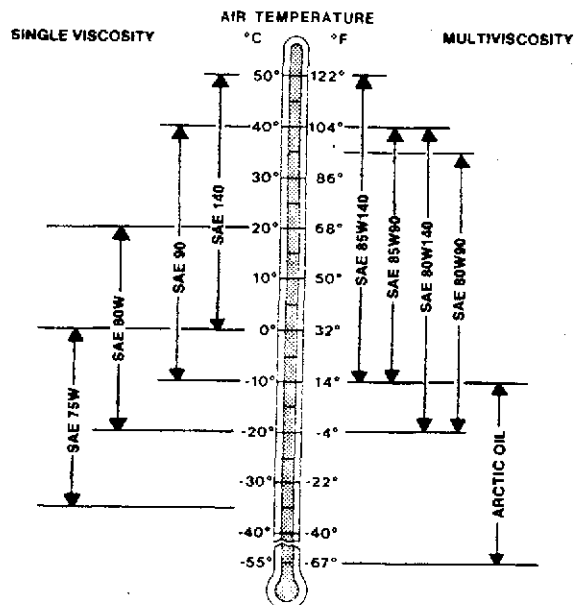

4EA;X9322 W11;;5LB D. 090686

## ALTERNATIVE LUBRICANTS

Additional information on cold weather operation is available from your John Deere dealer.

Conditions in certain geographical areas may require special lubricants and lubrication practices which do not appear in this operator's manual. If you have any questions, consult your John Deere dealer to obtain the latest information and recommendations.

053;ALTER. 050886

## LUBRICANT FOR DRIVE CHAINS

Lubricate with John Deere chain lube or the same oil being used in the engine.

Lubricate chains immediately after operation when the chain is warm.

*Main Drive Chain  
780 Spreader*

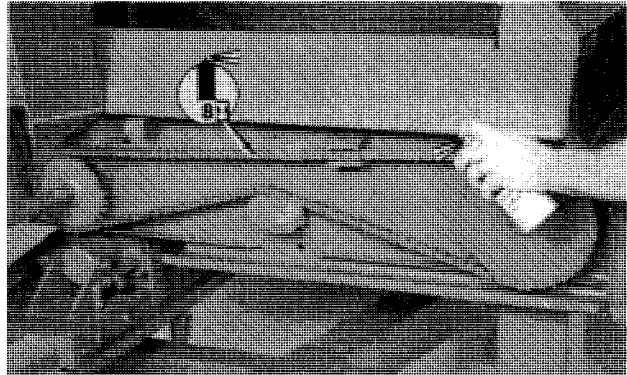

*Upper Beater Drive Chain  
780 Spreader*

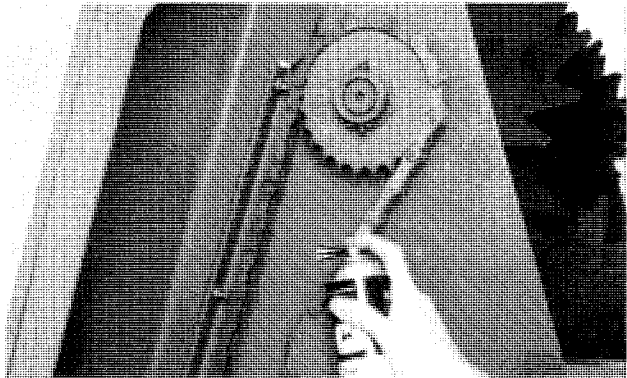

8DA;W13264 W13265 W01;;12LB -AF. 110587

## HYDRAULIC OIL

The cylinders in the spreader are extended using hydraulic oil from the tractor. Refer to the tractor operator's manual for specifications on oil.

W02;;1015 -D 150187

**SERIAL NUMBER**

The serial number plate is on the front right-hand side of the manure spreader.

When ordering parts, always furnish model and serial numbers as given on serial number plate.

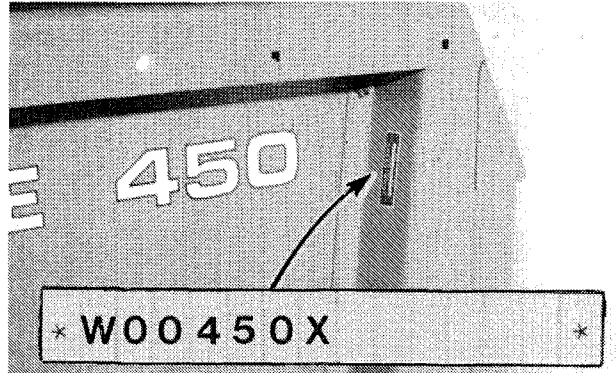

*450 Spreader*

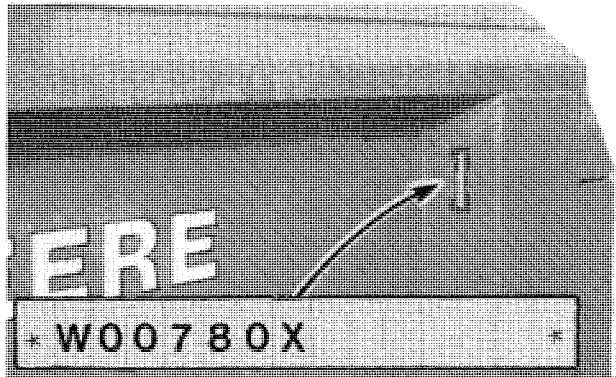

*780 Spreader*

8DA;W12451 W12236 W02;1020 -B 310387

# Section 20 BEATER DRIVE

## CONTENTS

	Page		Page
<b>GROUP 05—General Information</b> . . . . .	20-05-1	Remove Tube From Yoke . . . . .	20-15-18
		Replace Tube In Yoke . . . . .	20-15-19
<b>GROUP 10—Operational Checks</b>		Assemble Constant Velocity Joint . . . . .	20-15-19
Clutch Friction Disk Wear . . . . .	20-10-1	Disassemble Clutch Universal Joint . . . . .	20-15-21
Beater Driveline Bearings . . . . .	20-10-1	Assemble Clutch Universal Joint . . . . .	20-15-23
Upper Beater Shear Pin . . . . .	20-10-3		
<b>GROUP 15—Driveline Repair</b>		<b>GROUP 20—Clutch Repair</b>	
Exploded Driveline Views		Jaw-Type Clutch	
Powr-Gard . . . . .	20-15-1	Exploded View . . . . .	20-20-1
Shielded . . . . .	20-15-2	Remove . . . . .	20-20-1
Constant Velocity . . . . .	20-15-3	Disassemble . . . . .	20-20-2
Disassemble Powr-Gard Shield . . . . .	20-15-4	Inspect . . . . .	20-20-2
Assemble Powr-Gard Shield . . . . .	20-15-4	Assemble Jaw-Type Clutch . . . . .	20-20-4
Disassemble Regular Driveline Shield . . . . .	20-15-6	Install Jaw-Type Clutch . . . . .	20-20-6
Assemble Regular Driveline Shield . . . . .	20-15-6	Adjust Jaw-Type Clutch . . . . .	20-20-6
Disassemble Universal Joint . . . . .	20-15-7	Disk-Type Clutch	
Assemble Universal Joint . . . . .	20-15-8	Special Tool . . . . .	20-20-7
Disassemble Waltersheid Outer Driveline		Exploded View . . . . .	20-20-7
Shield With Locking Screw . . . . .	20-15-9	Remove . . . . .	20-20-8
Assemble Waltersheid Outer Driveline		Disassemble Disk-Type Clutch . . . . .	20-20-8
Shield With Locking Screw . . . . .	20-15-9	Inspect Disk-Type Clutch . . . . .	20-20-10
Disassemble Waltersheid Inner Driveline		Identify Belleville Springs Disk-Type	
Shield With Locking Screw . . . . .	20-15-11	Clutch . . . . .	20-20-10
Assemble Waltersheid Inner Driveline		Assemble Disk-Type Clutch . . . . .	20-20-11
Shield With Locking Screw . . . . .	20-15-11	Install Disk-Type Clutch . . . . .	20-20-14
Disassemble Waltersheid Outer Driveline			
Shield Without Locking Screw . . . . .	20-15-13	<b>GROUP 25—Input Shaft Repair</b>	
Assemble Waltersheid Outer Driveline		Essential Tools . . . . .	20-25-1
Shield Without Locking Screw . . . . .	20-15-13	Shaft Support Bearing Exploded View . . . . .	20-25-1
Disassemble Waltersheid Inner Driveline		Remove Input Shaft . . . . .	20-25-1
Shield Without Locking Screw . . . . .	20-15-14	Inspect Input Shaft . . . . .	20-25-2
Assemble Waltersheid Inner Driveline		Install Input Shaft Support Bearing . . . . .	20-25-2
Shield Without Locking Screw . . . . .	20-15-14	Install Input Shaft . . . . .	20-25-3
Disassemble Constant Velocity Joint . . . . .	20-15-15		
Inspect Coupler Yoke . . . . .	20-15-16	<b>GROUP 30—Drive Sprockets And Chain</b>	
Inspect Constant Velocity Joint		Repair	
Housing . . . . .	20-15-16	Chain Specifications . . . . .	20-30-1
		Inspect Drive Chain . . . . .	20-30-1
		Install And Adjust Drive Chain—450	
		Spreader . . . . .	20-30-1

Contents

	Page		Page
Install And Adjust Drive Chain—780			
Spreader . . . . .	20-30-2		
Drive Sprocket Assembly Exploded			
View . . . . .	20-30-3		
Remove Drive Sprocket . . . . .	20-30-3		
Inspect Drive Sprocket And Bearing . . . . .	20-30-3		
Install Drive Sprocket . . . . .	20-30-4		
Identify Side Shaft Sprocket . . . . .	20-30-5		
Remove Side Shaft Sprocket—450			
Spreader . . . . .	20-30-5		
Install Side Shaft Sprocket—450			
Spreader . . . . .	20-30-5		
Remove Side Shaft Sprocket—780			
Spreader . . . . .	20-30-6		
Install Side Shaft Sprocket—780			
Spreader . . . . .	20-30-7		
Checking Drive Chain Misalignment . . . . .	20-30-8		
 <b>GROUP 35—Beater Side Shaft Repair</b>			
Side Shaft And Shields Exploded			
View . . . . .	20-35-1		
Remove Side Shaft Shields . . . . .	20-35-2		
Remove Side Shaft . . . . .	20-35-2		
Inspect Side Shaft . . . . .	20-35-3		
Install Side Shaft . . . . .	20-35-3		
 <b>GROUP 40—Gear Case Repair</b>			
Specifications . . . . .	20-40-1		
Remove Gear Case . . . . .	20-40-1		
Gear Case Input Shaft Cross Section			
View—450 Spreader . . . . .	20-40-3		
Gear Case Output Shaft Cross Section			
View—450 Spreader . . . . .	20-40-4		
Gear Case Input Shaft Cross Section			
View—780 Spreader . . . . .	20-40-5		
Gear Case Output Shaft Cross Section			
View—780 Spreader . . . . .	20-40-6		
Disassemble Gear Case . . . . .	20-40-7		
Inspect Gears . . . . .	20-40-7		
Inspect Bearings . . . . .	20-40-8		
Assemble Gear Case Output Shaft—450			
Spreader . . . . .	20-40-9		
Assemble Gear Case Output Shaft—780			
Spreader . . . . .	20-40-10		
Measure Preload Torque—Output Shaft . . . . .	20-40-10		
Assemble Gear Case Input Shaft . . . . .	20-40-11		
Measure Preload Torque—Input Shaft . . . . .	20-40-12		
Measure Gear Backlash . . . . .	20-40-12		
Install Gear Case—450 Spreader . . . . .	20-40-14		
Install Gear Case—780 Spreader . . . . .	20-40-14		
 <b>GROUP 45—Main Beater Repair</b>			
Remove Beater . . . . .	20-45-1		
Inspect Beater . . . . .	20-45-2		
Replace Beater Hub—450 Spreader . . . . .	20-45-3		
Install Beater . . . . .	20-45-5		
Check Gear Case Runout—450 Spreader . . . . .	20-45-7		
 <b>GROUP 50—Upper Beater Repair</b>			
Upper Beater Exploded View—450			
Spreader . . . . .	20-50-1		
Upper Beater Drive Exploded View—450			
Spreader . . . . .	20-50-2		
Upper Beater Exploded View—780			
Spreader . . . . .	20-50-3		
Upper Beater Drive Exploded View—780			
Spreader . . . . .	20-50-4		
Inspect Beater . . . . .	20-50-5		
Install Upper Beater Support Bearing . . . . .	20-50-5		
Install Upper Beater Drive Hub—450			
Spreader . . . . .	20-50-5		
Adjust Upper Beater Drive Chain—450			
Spreader . . . . .	20-50-6		
Adjust Upper Beater Drive Chain—780			
Spreader . . . . .	20-50-6		
Replace Upper Beater Shear Pin—450			
Spreader . . . . .	20-50-6		
Replace Upper Beater Shear Pin—780			
Spreader . . . . .	20-50-7		

## DRIVE COMPONENTS

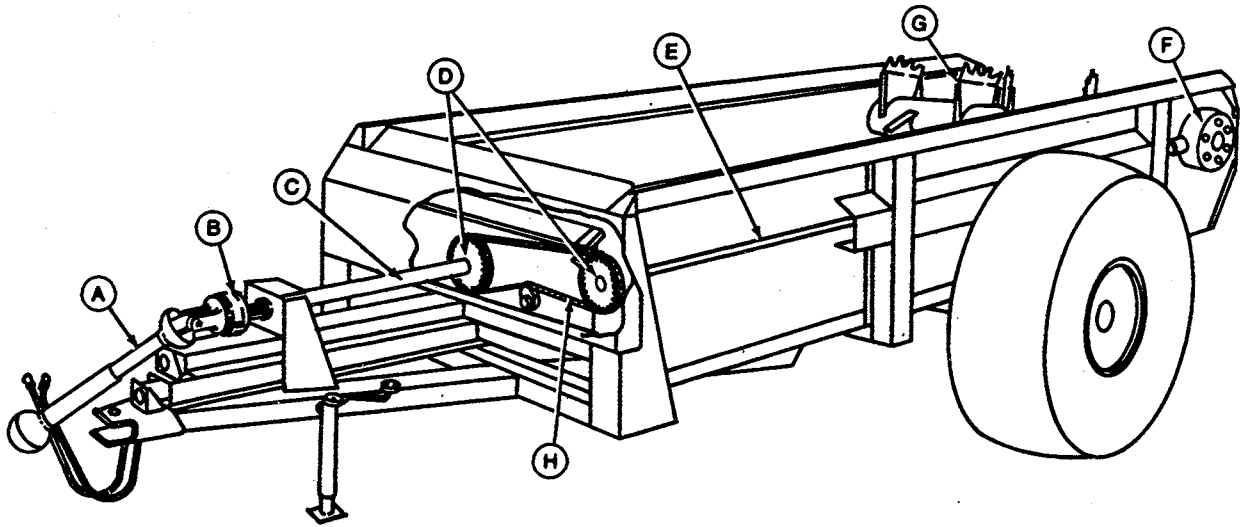

A—PTO Driveline  
B—Clutch

C—Input Shaft  
D—Drive Sprockets

E—Side Shaft  
F—Gear Case

G—Main Beater  
H—Drive Chain

5EA;W9970 W02;;2005 -A 130287

## PRINCIPLE OF OPERATION

Basically there are six components that operate the beater function of the spreader.

The driveline (A) connected to the tractor PTO shaft rotates clutch (B) driving sprockets (D) by means of input shaft (C). Power is then transferred to the side shaft (E) by drive chain (H). The side shaft runs the entire length of the spreader to gearcase (F), rotating the beater (G).

W02;;2005 -B 010487



**Download the full PDF manual instantly.**

**Our customer service e-mail:**

**[aservicemanualpdf@yahoo.com](mailto:aservicemanualpdf@yahoo.com)**