

**550A  
Crawler Bulldozer  
555A  
Crawler Loader**

# 550A CRAWLER BULLDOZER AND 555A CRAWLER LOADER TECHNICAL MANUAL TM-1292 (NOV-86)

## SECTION AND GROUP CONTENTS

### SECTION I—GENERAL INFORMATION

- Group I—Introduction and Safety Information
- Group II—General Specifications
- Group III—Cap Screw Torque Values
- Group IV—Lubrication

### SECTION 01—TRACKS

- Group 0130—Track Systems

### SECTION 02—AXLES AND SUSPENSION SYSTEMS

- Group 0250—Axle Shaft, Bearings, Reduction Gears and Steering Clutches

### SECTION 03—TRANSMISSION

- Group 0315—Controls
- Group 0350—Gears, Shafts, Bearings, Power Shift Clutch, and Torque Converter
- Group 0360—Transmission Hydraulics

### SECTION 04—ENGINE

- Group 0400—Removal and Installation
- Group 0401—Crankshaft and Main Bearings
- Group 0402—Camshaft and Valve Actuating Means
- Group 0403—Connecting Rods and Pistons
- Group 0404—Cylinder Block (Liners)
- Group 0407—Engine Oiling System
- Group 0409—Cylinder Head and Valves
- Group 0413—Fuel Injection System
- Group 0415—Engine Balancer

### SECTION 04—ENGINE—Continued

- Group 0416—Turbocharger
- Group 0417—Water Pump
- Group 0418—Thermostats, Housing and Piping
- Group 0419—Engine Oil Cooler
- Group 0420—Fuel Filter
- Group 0421—Fuel Transfer Pump
- Group 0422—Starting System
- Group 0433—Flywheel, Housing and Fasteners

### SECTION 05—ENGINE AUXILIARY SYSTEMS

- Group 0505—Cold Weather Starting Aids
- Group 0510—Cooling Systems
- Group 0515—Speed Controls
- Group 0560—External Fuel Supply Systems

### SECTION 06—TORQUE CONVERTER

- Group 0651—Converter, Turbine, Gears, and Shafts (See Group 0350).

### SECTION 09—STEERING SYSTEMS

- Group 0960—Power Steering

### SECTION 15—EQUIPMENT ATTACHING

- Group 1511—Drawbar

*Continued on next page*

## SECTION AND GROUP CONTENTS - Continued

### SECTION 16 - ELECTRICAL SYSTEMS

- Group 1671 - Batteries, Support and Cables
- Group 1672 - Alternator
- Group 1673 - Lighting System
- Group 1674 - Wiring Harness and Switches
- Group 1676 - Instruments and Indicators

### SECTION 17 - FRAME, CHASSIS, OR SUPPORTING STRUCTURE

- Group 1740 - Frame Installation
- Group 1746 - Frame Bottom Guards
- Group 1749 - Chassis Weights

### SECTION 18 - OPERATOR'S STATION

- Group 1810 - Operator Enclosure

### SECTION 19 - SHEET METAL

- Group 1910 - Hood or Engine Enclosure
- Group 1921 - Grille and Grille Housing

### SECTION 30 - WINCH

- Group 3015 - Controls Linkage
- Group 3050 - Winch Drive and Clutches
- Group 3060 - Winch Hydraulic System

### SECTION 31 - LOADER

- Group 3102 - Buckets
- Group 3103 - Forks
- Group 3115 - Controls Linkage
- Group 3140 - Frames
- Group 3160 - Hydraulic System

### SECTION 32 - BULLDOZER

- Group 3201 - Blades
- Group 3215 - Controls Linkage
- Group 3240 - Frames
- Group 3260 - Hydraulic System

### SECTION 33A - BACKHOE 9300

- Group 3300A - Removal and Installation
- Group 3302A - Bucket
- Group 3315A - Controls Linkage
- Group 3340A - Frames
- Group 3360A - Hydraulic System

### SECTION 33B - BACKHOE 9550

- Group 3300B - Removal and Installation
- Group 3302B - Bucket
- Group 3315B - Controls Linkage
- Group 3340B - Frames
- Group 3360B - Hydraulic System

### SECTION 37 - LOG ARCH

- Group 3740 - Arch Frames

### SECTION 40 - WINCH DRIVE

- Group 4051 - Gears, Shafts and Bearings

### SECTION 42 - GROUND CONDITIONING TOOL

- Group 4201 - Teeth and Shanks
- Group 4240 - Frame
- Group 4260 - Hydraulic System

### SECTION 90 - SYSTEM TESTING

- Group 9005 - General Information
- Group 9010 - Engine
- Group 9015 - Electrical System
- Group 9020 - Power Train
- Group 9025 - Hydraulic System
- Group 9030 - Miscellaneous Components

### SECTION 99 - SPECIAL TOOLS

### INDEX

## INTRODUCTION

This technical manual is part of a twin concept of service.

**FOS Manuals - for reference**

**Technical Manuals - for actual service**

The two kinds of manuals work as a team to give you both the general background and technical details of shop service.

*Fundamentals of Service (FOS) Manuals* cover basic theory of operation, fundamentals of troubleshooting, general maintenance, and basic types of failures and their causes. FOS Manuals are for training new personnel and for reference by experienced technicians.

*Technical manuals* are concise service guides for specific machines. Technical manuals are on-the-job guides containing only the vital information needed by an experienced service technician.



63A/T85956, T28:1 II01 150383

## FEATURES OF THIS TECHNICAL MANUAL

- John Deere ILLUSTRATION format emphasizing detailed pictures and fewer words in easy-to-use modules.
- Removal and installation groups preceding some repair groups.
- A section of system diagnostic testing.
- Table of contents of all sections at the front of the manual and a listing of all groups and headings at the front of each section.
- Special tools and specifications listed at the front of each group they are used in.
- Special tools illustrated in numerical order at end of manual.
- Alphabetical listing of all major components, specifications, and special tools.
- Safety rules, general specifications, and lubrication specifications.

This technical manual was planned and written for you - an experienced service technician. Keep it in a permanent binder in the shop where it is handy. Refer to it when you need to know correct service procedures or specifications.

Using the technical manual as a guide will reduce error and costly delay. It will also assure you the best in finished service work.



63A/T85959 T28:1 II15 150383

## SAFETY AND YOU



**CAUTION:** This safety symbol is used for important safety messages. When you see this symbol, follow the safety message to avoid personal injury.



83A/T81389 T28: I102 150383

## AVOID FIRE HAZARDS

Be prepared if an accident or fire should occur. Know where the first aid kit and the fire extinguishers are located — know how to use them.

Do not smoke while refueling or handling highly flammable material.

Shut off the engine when refueling.

Use care in refueling if the engine is hot.

Do not use open pans of gasoline or diesel fuel for cleaning parts. Use good commercial, nonflammable solvents.

Provide adequate ventilation when charging batteries.

Do not check battery charge by placing metal objects across the posts.

Do not allow sparks or open flame near batteries.

Do not smoke near battery.

Never check fuel, battery electrolyte, or coolant levels with an open flame.

Never use an open flame to look for leaks anywhere on the equipment.

Never use an open flame as light anywhere on or around the equipment.

When preparing engine for storage, remember that inhibitor is volatile and therefore dangerous. Seal and tape openings after adding the inhibitor. Keep container tightly closed when not in use.

Inspect electrical wiring for worn or frayed insulation. Install new wiring if wires are damaged.

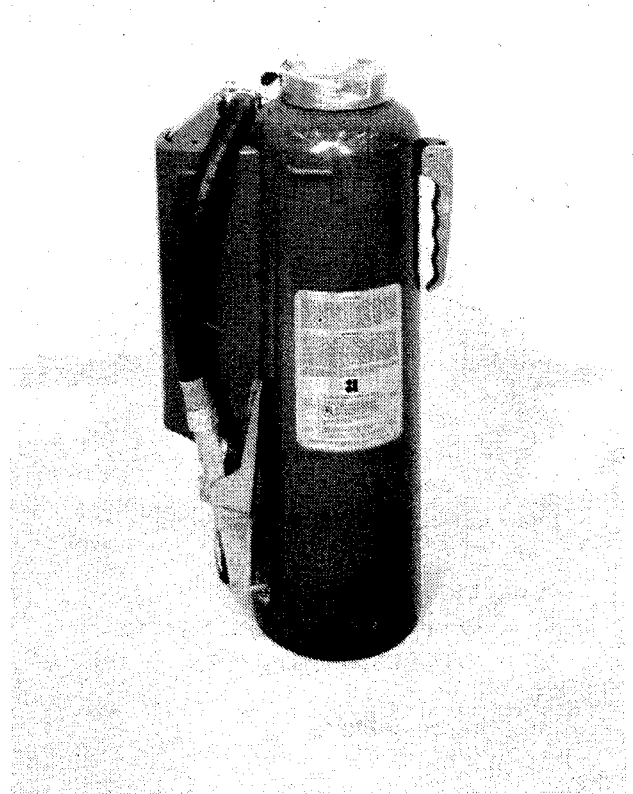

88A/T86875 T82:SKSA L 150383

## PREVENT FIRES BEFORE STARTING ENGINE

If machine is equipped with a fire extinguisher, check for correct charge.

Open both side shields and grille and remove trash.

Remove trash from other bottom guards, drive lines, batteries, hydraulic lines, fuel tank and operator's station.

Check for leaking fuel lines, hydraulic lines, hoses, or fittings with a piece of cardboard or wood. Do not use your hands. Tighten loose fittings. If lines are bent or hoses kinked, install new parts.

T82:CRSA A 080483

## PREVENT FIRES AFTER STOPPING ENGINE

Temperature in engine compartment may go up immediately after you stop the engine. **BE ON GUARD FOR FIRES.**

Before you clean trash from the engine compartment, wait until the engine has cooled. Open side shields to cool the engine faster. While the engine cools, clean trash from other areas.

T82:SKSA B 061282

## HANDLE STARTING FLUID SAFELY

If your machine is equipped with a starting fluid starting aid, remember starting fluid is highly flammable. **DO NOT** incinerate or puncture a starting fluid container. **DO NOT** store a starting fluid container in a high-temperature area.



88A:T90207 T82:CRSA G 210283

## UNDERSTAND MACHINE OPERATION

Only qualified people should operate the machine.

Learn the location and purpose of all controls, instruments, indicators, and labels.



88A:T90203 T82:CRSA B 210283

## WEAR PROTECTIVE CLOTHING

Wear fairly tight clothing . . . and safety equipment.



88A:T85056 T82:EXSA B 100183

## PROTECT AGAINST NOISE

Prolonged exposure to loud noise can cause impairment or loss of hearing. Wear a suitable hearing protective device such as earmuffs (A) or earplugs (B) to protect against objectionable or uncomfortable loud noise.

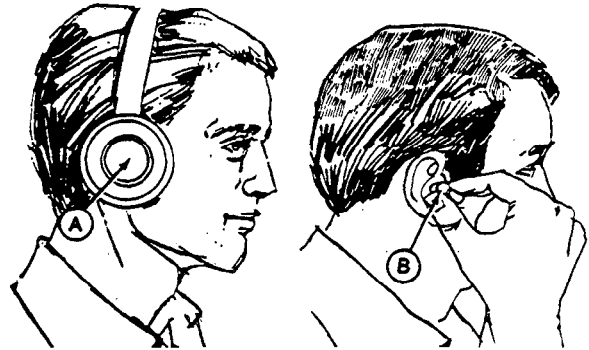

88A:X7662 T82:BHSA E 100183

## AVOID HIGH-PRESSURE FLUIDS

Escaping fluid under pressure can penetrate the skin causing serious injury. Relieve pressure before disconnecting hydraulic or other lines. Tighten all connections before applying pressure. Keep hands and body away from pinholes and nozzles which eject fluids under high pressure. Use a piece of cardboard or paper to search for leaks. Do not use your hand.

If ANY fluid is injected into the skin, it must be surgically removed within a few hours by a doctor familiar with this type injury or gangrene may result.

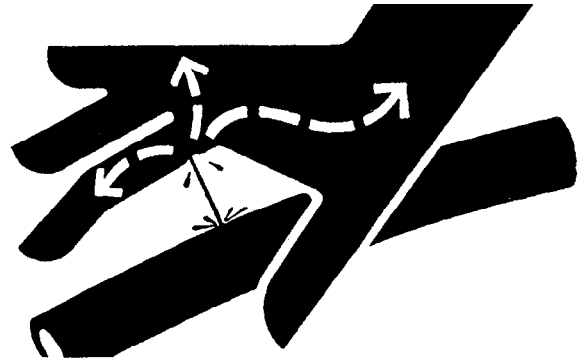

88A:X9811 T82:BHSA F 100183

## START ENGINE FROM OPERATOR'S SEAT ONLY

Avoid possible injury or death from machinery runaway.

Do not start engine by shorting across starter terminals. Machine will start in gear and will move if normal circuitry is bypassed.

NEVER start engine while standing on ground. Start engine only from operator's seat, with transmission in neutral, neutral-lock lever in LOCK position and brake lock lever engaged.

T82:CRSA AD 260483

### USE HAND HOLDS AND STEPS

When you get on and off the machine, use handholds and steps.



88A;T90204 T82;CRSA C 210283

### INSPECT MACHINE

Inspect your machine carefully each day before you start it. See "Pre-Start Inspection".

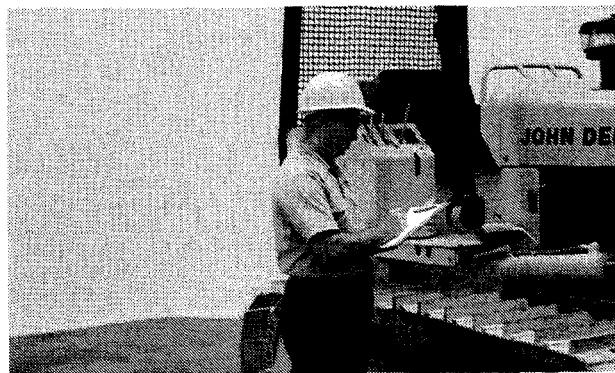

88A;T90205 T82;CRSA D 210283

### PARK SAFELY

Be sure equipment is on the ground or locked in position.  
Before leaving operator's seat be sure machine will not move.

Remove keys from switches and locks.

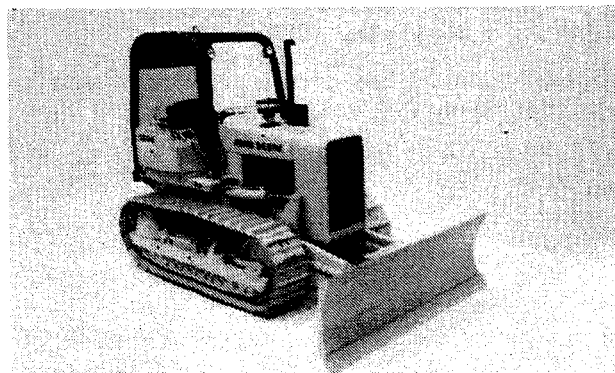

88A;T90987 T82;CRSA N 210283

Before you move any equipment, be sure all persons are away from the machine.

When the machine is operating, ONLY the operator should be on it.

Keep operating area level.

T82;CRSA F 210283



## TRACK SPECIFICATIONS

Distance across four links (new chain) .....	640.1 mm (25.2 in.)	Single grouser bar height (new shoe) .....	48.0 mm (1.89 in.)
100% wear limit .....	652.8 mm (25.7 in.)	100% wear limit .....	20.0 mm (0.79 in.)
Link height (new chain) .....	90 mm (3.54 in.)	Semi-grouser bar height (new shoe) .....	21.1 mm (0.83 in.)
100% wear limit .....	82.8 mm (3.26 in.)	100% wear limit .....	12.0 mm (0.47 in.)
Bushing O.D. (new bushing) .....	51 mm (2.01 in.)	Upper track carrier roller OD (new) .....	152.4 mm (6.0 in.)
100% wear limit (normal loading) .....	46 mm (1.81 in.)	100 % wear limit .....	139.7 mm (5.50 in.)
100% wear limit (high shock loading) ..	48 mm (1.89 in.)	Track roller OD (new) .....	182.6 mm (7.19 in.)
Bushing stickout .....	7.44 mm (0.298 in.)	100% wear limit .....	168.2 mm (6.62 in.)
		Front idler flange height (new) .....	19.3 mm (0.76 in.)
		100% wear limit .....	24.4 mm (0.96 in.)

T47;0130 02 060983

## REMOVE TRACK CHAIN

1. Rotate track to position the master pin on the front idler as shown.

*NOTE: Master pin is identified by drill point in end of pin.*



**CAUTION: Make sure track clears floor before rotating.**

2. Remove two track shoes; one on each side of master pin.

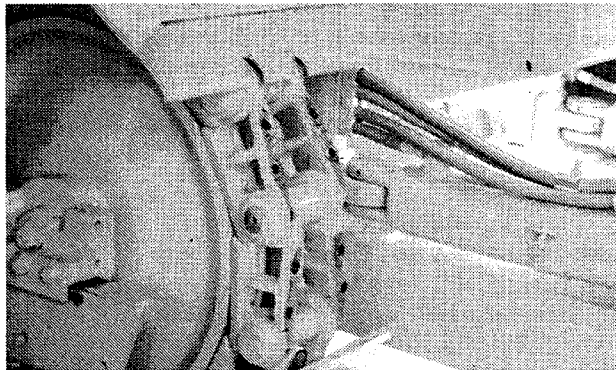

2AG;T93554 T47;0130 30 220783

3. Release track tension by loosening nut (A) and turn set screw (B) out of the track adjusting cylinder (C) approximately three turns.

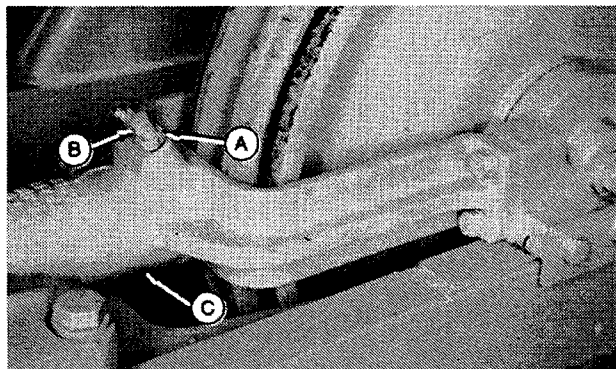

2AG;T93555 T47;0130 31 220783

**IMPORTANT:** Do not remove the track master pin with a hammer. This will enlarge the link pin bore requiring installation of a new track link.

4. Remove master pin from track link using D-01030AA Master Pin Pusher. Install aligning adapter (A) into master pin pusher C-frame securing with holding screw (B). Put aligning bushings (C) over forcing pin (D) and install adapter (E) in C-frame.

A—Aligning Adapter    C—Aligning Bushing    E—Pin Adapter  
B—Holding Screw    D—Forcing Pin

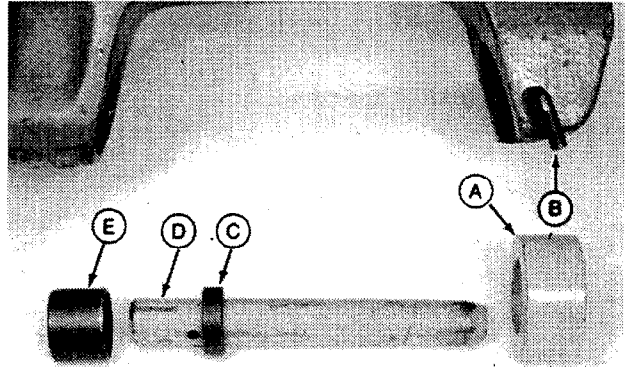

2AG:T93556 T47:0130 32 220783

5. Position master pin pusher and forcing pin in alignment with master pin using load positioning sling and hoist.

6. Turn ram adjusting screw (B) clockwise with crank until forcing pin (A) contacts master pin.

7. Connect hand pump to pin pusher. Activate pump to remove master pin.

8. Remove forcing pin to separate track.

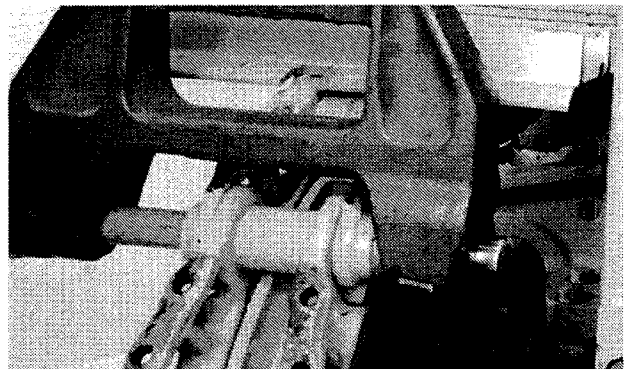
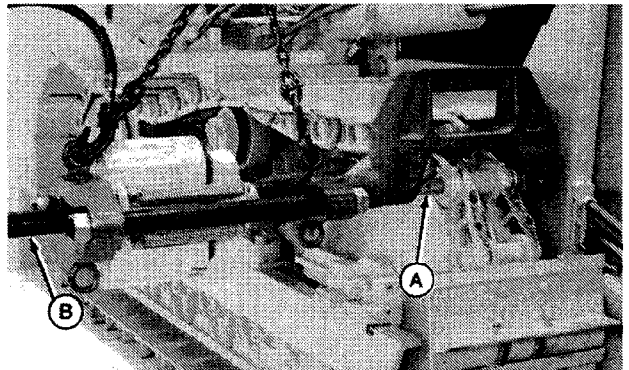

2AG:T93557,T93644 T47:0130 33 220783

9. Pull track chain apart. Remove spacers (B) and seals (A) from between left and right track links.

10. Lift side of machine or operate crawler and rotate track in the reverse direction. Slowly, unwrap track off drive sprocket.

11. Place a jack under both crossbars and raise crawler to provide clearance. Block crawler up securely.

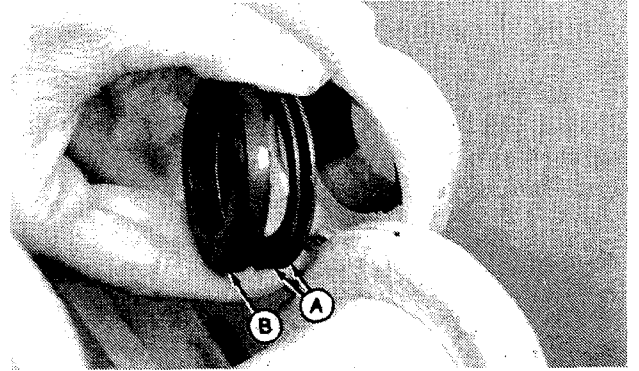

2AG;T93558 T47;0130 34 220783

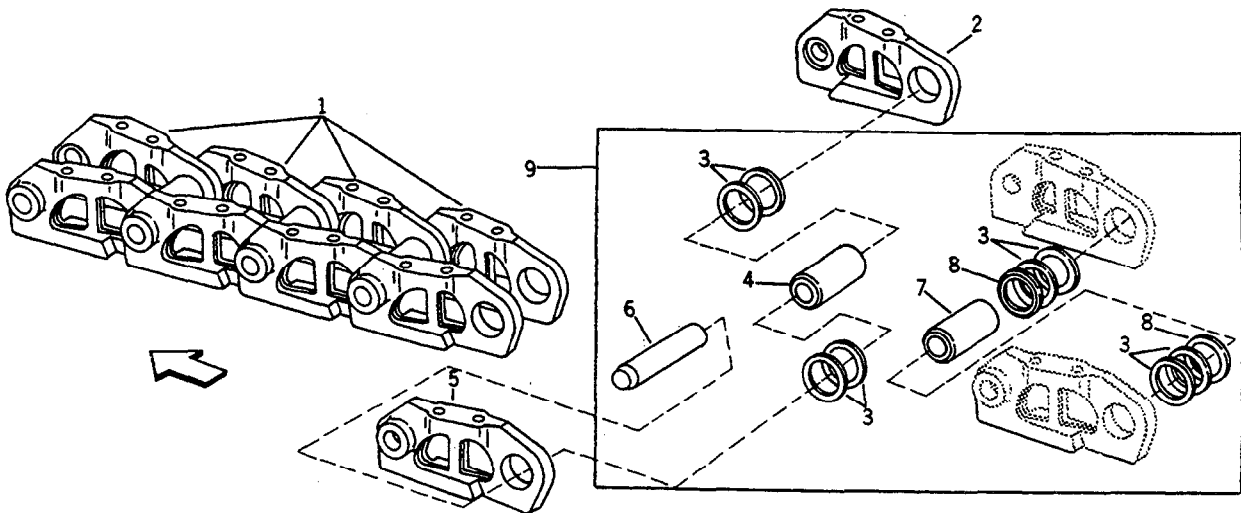

T59376F

1—Track Chain  
2—Right Track Link  
3—Belleville Seals

4—Bushing  
5—Left Track Link

6—Pin, Standard  
Pin, Master  
(Drill Point On End)

7—Master Bushing  
8—Spacer (Master Bushing)  
9—Pin and Bushing Repair Kit

2AG;T59376 T47;0130 03 220783

## DISASSEMBLE TRACK CHAIN



**CAUTION:** Always wear safety glasses when operating press. Parts may break or chip, causing eye injuries.

1. Remove track shoes from chain.
2. Install 40989 Saddle from 26815 Track Disassembly and Assembly Tooling Kit in track press frame and secure with cap screws.

T47;0130 04 220783



**Download the full PDF manual instantly.**

**Our customer service e-mail:**

**[aservicemanualpdf@yahoo.com](mailto:aservicemanualpdf@yahoo.com)**