

# 5200 and 5400 Self-Propelled Forage Harvester



JOHN DEERE

## TECHNICAL MANUAL 5200 and 5400 Self-Propelled Forage Harvester

TM1066 (01MAY76) English

John Deere Ottumwa Works  
TM1066 (01MAY76)

LITHO IN U.S.A.  
ENGLISH

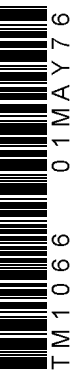

## SAFETY AND YOU



T27999N

### INTRODUCTION

 This safety alert symbol identifies important safety messages in this manual and on the harvester. When you see this symbol, be alert to the possibility of personal injury and carefully read the message that follows.

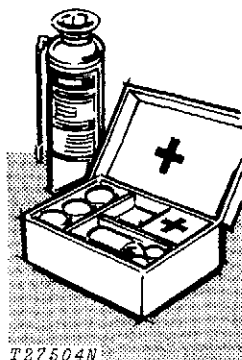

T27504N

Be prepared if an accident or fire should occur. Know where the first aid kit and the fire extinguishers are located—know how to use them.

### SERVICE AREA

Keep the service area clean and dry. Wet or oily floors are slippery. Wet spots can be dangerous when working with electrical equipment.

Make sure the service area is adequately vented.

Periodically check the shop exhaust system for leakage. Engine exhaust gas is dangerous.

Be sure all electrical outlets and tools are properly grounded.

Use adequate light for the job at hand.

### AVOID FIRE HAZARDS



E11334N

WRONG

Don't smoke while refueling or handling highly flammable material.

Engine should be shut off when refueling.

Use care in refueling if the engine is hot.

Don't use open pans of gasoline or diesel fuel for cleaning parts. Good commercial, nonflammable solvents are preferred.

Provide adequate ventilation when charging batteries.

Don't check battery charge by placing metal objects across the posts.

Don't allow sparks or open flame near batteries.

Don't smoke near battery.

Never check fuel, battery electrolyte or coolant levels with an open flame.

Never use an open flame to look for leaks anywhere on the equipment.

Never use a open flame as a light anywhere on or around the equipment.

When preparing engine for storage, remember that inhibitor is volatile and therefore dangerous. Seal and tape openings after adding the inhibitor. Keep container tightly closed when not in use.

## CLEANING THE HARVESTER

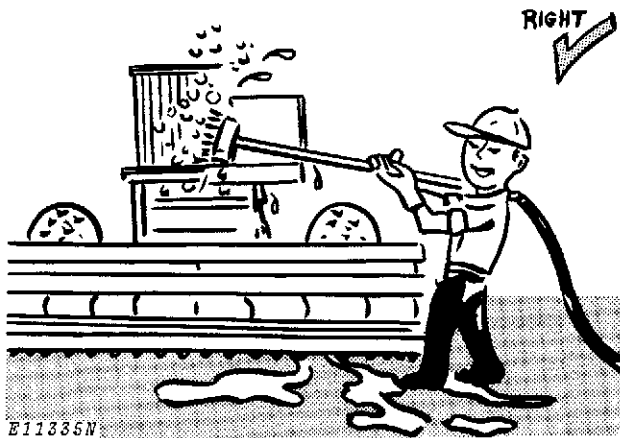

Always stop the engine before cleaning the harvester.

Keep the operator's platform clean. Do not use it as a storage area.

Keep the radiator screen free of foreign matter. Avoid a possible fire hazard.

Keep all equipment free of dirt and oil. In freezing weather, beware of snow and ice on ladder steps and operator's platform.

## FLUIDS UNDER PRESSURE

Escaping fluid under pressure can have sufficient force to penetrate the skin, causing serious personal injury. Before disconnecting lines, be sure to relieve all pressure. Before applying pressure to the system, be sure all connections are tight and that lines, pipes and hoses are not damaged. Fluid escaping from a very small hole can be almost invisible. Use a piece of cardboard or wood, rather than hands, to search for suspected leaks.

If injured by escaping fluid, see a doctor at once. Serious infection or reaction can develop if proper medical treatment is not administered immediately.

Don't forget the hydraulic system or diesel fuel injection system may be pressurized! To relieve pressure, follow the instructions in this technical manual.

When checking hydraulic pressure, be sure to use the correct test gauge for the pressure in the particular system.

## PERSONAL SAFETY

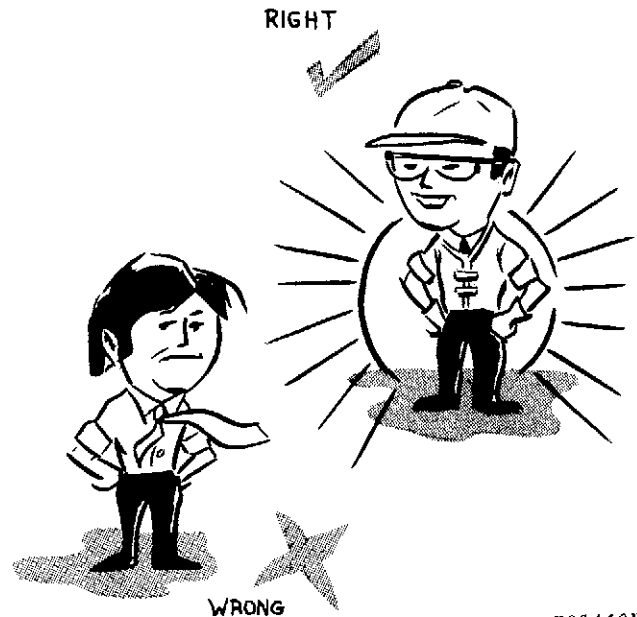

Always avoid loose clothing or any accessory—flopping cuffs, dangling neckties and scarves—that can catch in moving parts and put you out of work. Always wear your safety glasses while on the job.

Keep transmission and brake control units properly adjusted at all times. Before making adjustments, stop engine.

Before removing any housing covers, stop engine. Take all objects from your pockets which could fall into the opened housings. Don't let adjusting wrenches fall into opened housings.

Don't attempt to check belt tension while the engine is running.

Don't adjust the fuel system while the machine is in motion.

Before repairing the electrical system, or performing a major overhaul, make sure the batteries are disconnected.

Avoid working on equipment with the engine running. If it is necessary to make checks with the engine running, **ALWAYS USE TWO MEN**—one, the operator, at the controls, the other checking where the operator can see him. Also, put the transmission in neutral, set the brake, and apply any safety locks provided. **KEEP HANDS AWAY FROM MOVING PARTS.**

Use extreme caution in removing radiator caps, drain plugs, grease fittings, or hydraulic pressure caps.

# Section 10 GENERAL

## CONTENTS OF THIS SECTION

	Page		Page
GROUP 5 - SPECIFICATIONS		GROUP 20 - LUBRICATION	
Specifications .....	5-1	General Information .....	20-1
		Lubricants .....	20-2
GROUP 10 - PREDELIVERY, DELIVERY, AND AFTER-SALE SERVICES		GROUP 25 - DIAGNOSING AND TESTING PROCEDURES .....	25-1
Predelivery Service .....	10-1		
Delivery Service .....	10-10	GROUP 30 - SEPARATION	
After-Sale Inspection .....	10-10	Operator's Cab .....	30-1
Torque Chart .....	10-8	Operator's Platform .....	30-3
		Auger Assembly .....	30-3
GROUP 15 - TUNE-UP		Cutterhead and Feed Roll Assembly .....	30-4
General Information .....	15-1	Engine .....	30-5
Preliminary Engine Testing .....	15-1		
Engine Tune-Up .....	15-1	GROUP 35 - TORQUE VALUES AND SPECIAL TOOLS	
Final Engine Testing .....	15-3	Torque Values .....	35-1
Miscellaneous Testing .....	15-3	Special Tools .....	35-1

## Group 5 SPECIFICATIONS

### ENGINE

Horsepower:	
5200 ( -124495) . . . . .	160 (119 kW)* 135 (101 kW)**
5200 (124496- ) . . . . .	175 (130 kW)* 150 (112 kW)**
5400 . . . . .	212 (158 kW)* 185 (138 kW)**
Type . . . . .	6-cylinder, in-line valve- in-head, diesel, turbo- charged and inter-cooled
Bore and stroke	
5200 . . . . .	4-1/4 in. x 4-3/4 in. 10.8 cm x 12.1 cm
5400 . . . . .	4-3/4 in. x 5 in. 12.1 cm x 12.7 cm
Displacement	
5200 . . . . .	404 cu. in. (6620 cm <sup>3</sup> )
5400 . . . . .	531 cu. in. (8701 cm <sup>3</sup> )
Compression ratio	
5200 ( -124495) . . . . .	16.8 to 1
5200 (124496-285,000) . . . . .	15.5 to 1
5200 (285,001- ) . . . . .	14.7 to 1
5400 . . . . .	15.4 to 1
Firing order . . . . .	1-5-3-6-2-4
Valve clearance . . . . .	Intake-0.018 in. (0.46 mm) Exhaust-0.028 in. (0.71 mm)
Injection pump timing - 5200 . . . . .	TDC
5400 . . . . .	24°BTDC
Engine Speeds	
Working speed . . . . .	2100 rpm
Slow idle . . . . .	800 rpm
Fast idle (Full load) . . . . .	2100 rpm
(No load) . . . . .	2300 rpm

LUBRICATION SYSTEM . . . . . Full pressurized  
with full-flow micronic oil  
filter, water-cooled oil  
cooler, and bypass valves  
for filter and cooler.

\*Factory observed net horsepower at flywheel less fan measured at 85°F (30°C), 29.3 in. Hg. operating at 2100 rpm.

\*\*Factory observed net horsepower at cutterhead drive sheave operating at 2100 rpm.

### FUEL SYSTEM:

Type . . . . .	Direct injection
Filter . . . . .	Two-stage with replaceable impregnated paper element.
Injection pump type:	
5200 ( -124495) . . . . .	Inlet metering, distributing type
5200 (124496- ) and 5400 . . . . .	Multiple plunger, in line
Air cleaner . . . . .	Dry element with self-cleaning precleaner and safety element

### COOLING SYSTEM:

Type . . . . .	Pressurized with centrifugal pump
Temperature control . . . . .	Heavy-duty thermostats

### ELECTRICAL SYSTEM:

Type . . . . .	12-volt, negative grounded
Batteries . . . . .	Two, 6-volt 87-plate 204- ampere-hour, 7D type, connected in series
Alternator:	
5200 . . . . .	12-volt, 55-amp, with integral transistorized regulator.
5400 . . . . .	12-volt, 55-amp capacity
5200 and 5400 (with air conditioned cab) . . . . .	72-amp

### MAIN CLUTCH (Blower Fan and Cutterhead Drive):

Type . . . . .	Over-center, dry, metallic button, adjustable
Number of disks . . . . .	2
Diameter . . . . .	12 in. (30.5 cm)
Actuated . . . . .	Hand lever

### TRANSMISSION:

Type . . . . .	Automotive spur gear with four speeds. Transmission is equipped with neutral safety switch.
----------------	---

### FINAL DRIVE:

Type . . . . .	Pinion and ring gear
----------------	----------------------

**GROUND SPEEDS IN MPH (kmh)\***  
 (2100 engine rpm)

Gear	2 Wheel Drive With 18.4-26 and 16.9-26 Tires	
	1st	0-1.64 (2.6)
2nd	0-3.77 (6.1)	0-3.55 (5.7)
3rd	0-6.86 (11.0)	0-6.46 (10.4)
4th	0-16.80 (27.0)	0-14.90 (24.0)

Gear	Power Rear Wheel Drive With 18.4-26 and 16.9-26 Tires	
	1st	0-1.40 (2.3)
2nd	0-2.80 (4.5)	0-2.65 (4.3)
3rd	0-4.35 (7.0)	0-4.10 (6.6)
4th	0-6.95 (11.2)	0-6.15 (9.9)

*\*Reverse Ranges: (Ground travel speeds are approximately one-half the forward range.)*

**HYDROSTATIC SYSTEM (Ground Drive):**

**Pump:**  
 Type ..... Variable displacement  
   Sunstrand 23 Series  
 Speed ..... 2100 rpm  
 Displacement ..... 0-5.43 cu. in. (89 cm<sup>3</sup>)  
   per revolution

**Charge Pump:**  
 Type ..... Gear  
 Speed ..... 2100 rpm  
 Displacement ..... 1.1 cu. in. (18.0 cm<sup>3</sup>)  
   per revolution  
 Flow rate ... 10 gpm (37.9 lpm) at 2100 rpm

**Motor:**  
 Type ..... Fixed displacement  
   Sunstrand 23 Series  
 Speed ..... 0-2100 rpm  
 Displacement ..... 5.43 cu. in. (88.98 cm<sup>3</sup>)  
   per revolution  
 Relief pressure ..... 5000 psi (34500 kPa)  
 Flow rate ..... 49 GPM (185 lpm) at 2100 rpm

**HYDRAULIC SYSTEM (Machine Functions):**

Type: Open-center, constant-flow system. Includes power steering, header lift, spout rotation, cutterhead reverse grinder drive, and breakaway coupler (Optional)  
**Pump** ..... Gear-type  
 Relief pressure ..... 2000 psi (13800 kPa)  
 Flow rate: Steering  
 (Priority) ..... 2.75 gpm (10.4 lpm)  
 Total ..... 10.2 gpm (38.6 lpm)  
 Speed ..... 2100 rpm

**STEERING:**

Type ..... Full power hydraulic

**TIRE OPTIONS:**

**Front Wheels: (8-ply rated)**  
 5200 ..... ( -285,000) 16.9-26; 8 pr.  
   18.4-26; 10 pr.  
 5400 ..... 18.4-26; 10 pr.  
**Rear Wheels: (6-ply rated, 3-rib implement)**  
 5200 ..... ( -285,000) 7.50-18; 6 pr.  
   11.00-16; 6 pr.  
 5400 ..... 11.00-16; 6 pr.  
 Power rear wheel drive ..... 11.2-24 (4-ply rated,  
   cleat type)

**BRAKES:**

Type: 12-inch (30.48 cm) hydraulically actuated shoe-type. Individual brakes controlled by separate pedals.

**CUTTERHEAD:**

Type ..... Helical  
 Diameter ..... 24 in. (60.96 cm)  
 Width ..... 22 in. (55.88 cm)  
 Knives ..... Nine, J-style, tungsten carbide edge  
 Speed ..... 850 rpm  
 Drive ..... Three matched C-section belts

**CUTTERHEAD REVERSE GRINDER:**

Drive ..... Hydraulic motor  
 Speed ..... 425 rpm

**BLOWER:**

Type ..... Lagged Radial Paddle  
 Diameter ..... 32 in. (81.3 cm)  
 Number of paddles ..... 4  
 Speed ..... 1020 rpm

**AUGERS:**

Number ..... 2  
 Drive ..... Chain from cutterhead  
 Diameter ..... 10 in. (25.4 cm)  
 Speed ..... 558 rpm  
 Discharge ..... Side flow to blower fan

**POWER REAR WHEEL DRIVE (Optional):**

Type ..... Hydrostatic motor driven with planetary gear reduction in wheel hub, uses pressure oil from hydrostatic system  
 Controls ..... Solenoid operated control valves, by electric switch on console  
 Planetary disconnect ..... Hydraulic wet brake on ring gear releases when drive is disengaged

## CAPACITIES:

Fuel tank	72 U.S. gals. (272.5 l)
Cooling system:	
5200	11 U.S. gals. (41.6 l)
5400	15 U.S. gals. (56.8 l)
Engine crankcase (including oil filter)	
5200	17 U.S. qts. (16.1 l)
5400	26 U.S. qts. (24.6 l)
Transmission	11 U.S. qts. (10.4 l)
Feed roll drive case	3 U.S. qts. (2.8 l)
Final drives (two)	8 U.S. qts. ea. (7.6 l)
Main gear case	2 U.S. gals. (7.6 l)
Hydraulic system (including oil lines and cylinders)	3 U.S. gals. (11.3 l)
with hydraulic outlet	5 U.S. gals. (19 l)
Hydraulic brake master cylinder	1 U.S. Pt. (0.5 l) (approx.)
Hydrostatic drive system (including lines and components) (add 4-1/2 gals. [15.1 l] to capacity if equipped with Power Rear Wheel Drive)	7 U.S. gals. (26.5 l)

## TIRE INFLATION PRESSURES:

Front Wheels	26 psi (179 kPa)
	Torque to 300 ft-lbs (407 Nm)
Rear Wheels	20 psi (138 kPa)
	Torque to 90 ft-lbs (122 Nm)
Pickup Gauge Wheels	30 psi (207 kPa)

## WEIGHT:

5200 with cab and power rear axle	12375 lbs (5569 kg)
5400 with cab and power rear axle	12982 lbs (5842 kg)

## OPERATOR'S CAB

Cab Glass	46 square feet (4.27 m <sup>2</sup> )
Pressure Fans (Blower)	
Capacity	435 cubic feet (10.42 m <sup>3</sup> ) per minute
Filter	Removable, reuseable, dry-type, paper element; 37 x 6-1/8 x 2-3/16 in. (940 x 156 x 56 mm)
Heater	
Capacity	18,000 BTU 300 cubic feet (8.50 m <sup>3</sup> ) per minute
Air conditioner	
Capacity	20,000 BTU 300 cubic feet (8.50 m <sup>3</sup> ) per minute
Refrigerant	Refrigerant 12
Filters	Removable, reuseable, urethane foam; one each in normal and maximum air recirculators.
Fuses:	
Electric Clutch	7.5 Amp.
Radio	2 Amp.
Dome Light	7.5 Amp.
Windshield Wiper	7.5 Amp.
Condenser Fans	30 Amp.
Pressurizer Fans (Blower)	30 Amp.
Lamps:	
Head	15 Amp.
Tail	15 Amp.
Warning	15 Amp.
Spout	15 Amp.

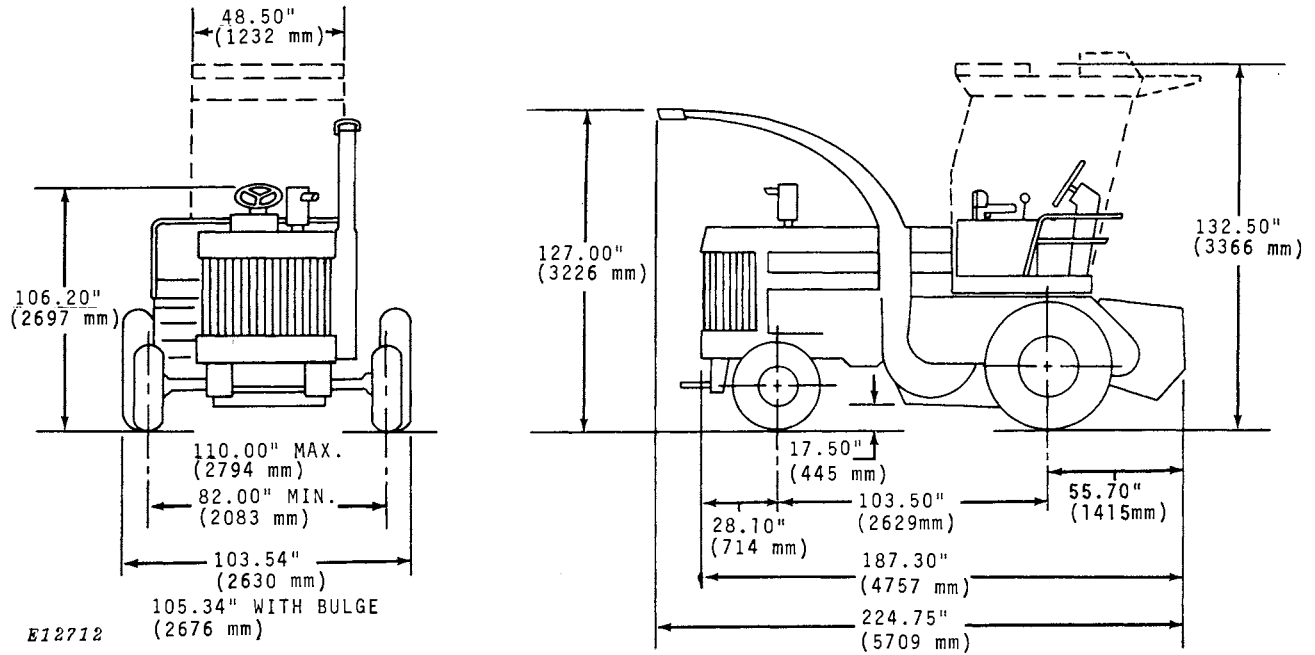

Fig. 1-Dimensions of 5200 and 5400 Self-Propelled Harvesters  
With 18.4 x 26 Front Tires and  
11.2 x 24 Rear Tires



## Group 10 PREDELIVERY, DELIVERY AND AFTER-SALE SERVICES

### TEMPORARY UNIT STORAGE

After receiving your unit from the factory and before putting the machine into temporary storage, perform the following checks.

For long term storage (over 30 days) information, consult your operator's manual.

1. Check battery electrolyte level and charge the battery, if necessary.
2. Check the level of coolant in the radiator. The coolant should be maintained at a level 2 inches (51 mm) above the baffle.
3. Fill the fuel tank.
4. Check crankcase oil level. Oil should be above bottom mark of dipstick after machine has been shut down for 10 minutes.
5. Relieve hydraulic pressure by stopping engine and operating control levers until system fails to respond.
6. Reduce shipping pressure of all tires to inflation pressure. Shown on page 10-15-3.
7. Cover unit for protection and cleanliness.

### PREDELIVERY SERVICE

Because of the shipping factors involved, plus extra finishing touches that are necessary to promote customer satisfaction, proper predelivery service is of prime importance to the dealer and the customer.

**NOTE:** A protective cover is placed over the muffler outlet to prevent turbocharger rotation during transit. Remove protective cover before unloading harvester. Reinstall protective cover before transporting the harvester to the customer if machine is to be moved at highway speeds.

After completing the factory-recommended dealer checks and services listed on the predelivery tag, remove the tag from the harvester and file it with the shop order for the job. The tag will certify that the harvester has received the proper predelivery service when that portion of the customer's John Deere Delivery Receipt is completed.

Use the following list when preparing a unit for delivery to the customer.

#### 1. Pre-Cleaner

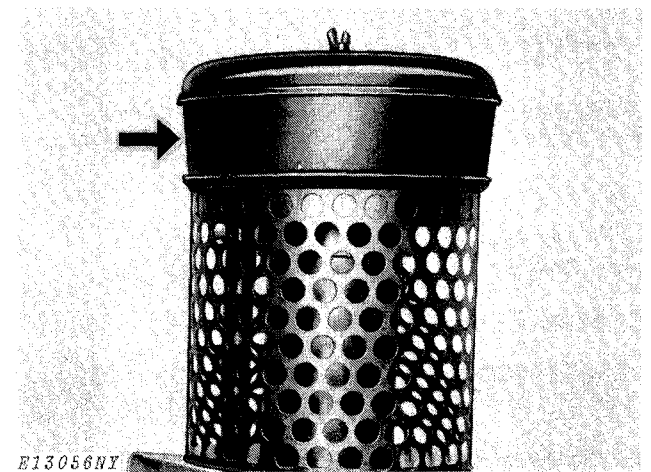

Fig. 1-Pre-cleaner

Check and clean pre-cleaner bowl.  
Pre-cleaner checked and cleaned.

Yes \_\_\_\_\_

## 2. Air Cleaner

Check air cleaner restriction indicator lamp on instrument panel. If indicator shows red, check and clean both primary and safety filter elements. Replace elements, if necessary.

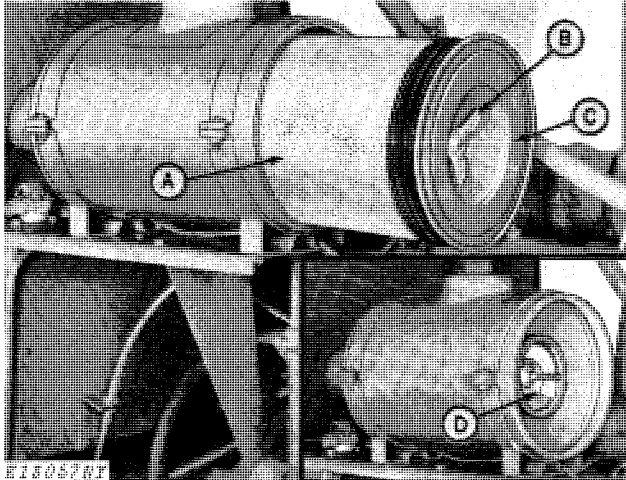

A—Primary Filter Element      C—Air Cleaner Cover  
 B—Wing Nut                      D—Safety Filter Element

Fig. 2—Air Cleaner

Air Cleaner checked                      Yes \_\_\_\_\_  
 Filters Replaced                          Yes \_\_\_\_\_

## 3. Fuel Filters

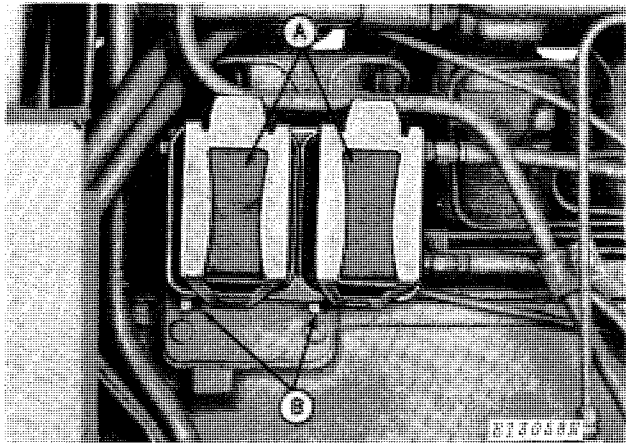

A—Fuel Filters                              B—Drain Plugs

Fig. 3—Fuel Filters

Check fuel filters and drain any sediment that is present. (See Section 30)

Fuel filters checked                      Yes \_\_\_\_\_  
 Sediment present in filters              Yes \_\_\_\_\_

## 4. Batteries

Check battery electrolyte level. If distilled water is not available, use clean soft water. Avoid use of hard water. Remove foreign material from top of battery and coat terminals with petroleum jelly. Clean vent holes in battery caps.

**IMPORTANT: Never add water to battery in freezing weather unless engine is to be run long enough (2 or 3 hours) to assure mixing of water and electrolyte.**

Check battery connection.  
 Punch date code on battery.

Battery Connections checked              Yes \_\_\_\_\_  
 Water added                                  Yes \_\_\_\_\_

## 5 Fuel Tank

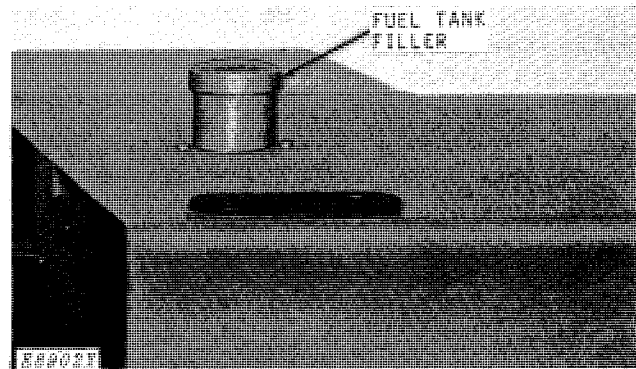

Fig. 4—Fuel Tank Filler Cap

Check the fuel gauge. If fuel gauge indicates a low supply of fuel, fill the tank. Fuel tank capacity is 72 U.S. gals (273 l).

Fuel tank level                              Full   1/2 Full   Empty



**Download the full PDF manual instantly.**

**Our customer service e-mail:**

**[aservicemanualpdf@yahoo.com](mailto:aservicemanualpdf@yahoo.com)**