

JOHN DEERE
WORLDWIDE COMMERCIAL & CONSUMER
EQUIPMENT DIVISION

Compact Utility Tractor
4105

TM102419 DECEMBER 2010

TECHNICAL MANUAL



JOHN DEERE

North American Version
Litho In U.s.a.

INTRODUCTION

Introduction

Manual Description

This technical manual is written for an experienced technician and contains sections that are specifically for this product. It is a part of a total product support program.

The manual is organized so that all the information on a particular system is kept together. The order of grouping is as follows:

- Table of Contents
- Specifications and Information
- Identification Numbers
- Tools and Materials
- Component Location
- Schematics and Harnesses
- Theory of Operation
- Operation and Diagnostics
- Diagnostics
- Tests and Adjustments
- Repair
- Other

Note: *Depending on the particular section or system being covered, not all of the above groups may be used.*

The bleed tabs for the pages of each section will align with the sections listed on this page. Page numbering is consecutive from the beginning of the Safety section through the last section.

We appreciate your input on this manual. If you find any errors or want to comment on the layout of the manual please contact us.

Safety

Specifications and Information

Engine

Electrical

Power Train

Final Drive

Hydraulics

Steering

Brakes

Miscellaneous

SAFETY

Safety

Recognize Safety Information



MIF

This is the safety-alert symbol. When you see this symbol on your machine or in this manual, be alert to the potential for personal injury.

Follow recommended precautions and safe servicing practices.

Understand Signal Words

A signal word - DANGER, WARNING, or CAUTION - is used with the safety-alert symbol. DANGER identifies the most serious hazards.

DANGER or WARNING safety signs are located near specific hazards. General precautions are listed on CAUTION safety signs. CAUTION also calls attention to safety messages in this manual.

Special Messages

Your manual contains special messages to bring attention to potential safety concerns, machine damage as well as helpful operating and servicing information. Please read all the information carefully to avoid injury and machine damage.



Caution: Avoid Injury! This symbol and text highlight potential hazards or death to the operator or bystanders that may occur if the hazards or procedures are ignored.

Important: Avoid Damage! This text is used to tell the operator of actions or conditions that might result in damage to the machine.

Note: General information is given throughout the manual that may help the operator in the operation or service of the machine.

Replace Safety Signs



MIF

Replace missing or damaged safety signs. See the machine operator's manual for correct safety sign placement.

Handle Fluids Safely - Avoid Fires

Be Prepared For Emergencies

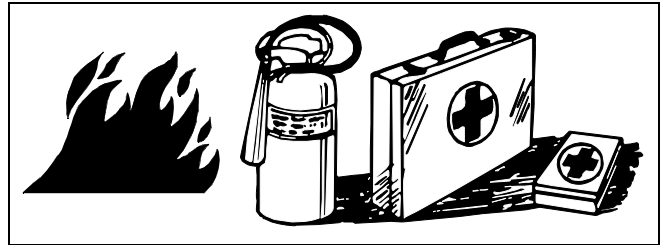

MIF

- When you work around fuel, do not smoke or work near heaters or other fire hazards.
- Store flammable fluids away from fire hazards. Do not incinerate or puncture pressurized containers.
- Make sure machine is clean of trash, grease, and debris.
- Do not store oily rags; they can ignite and burn spontaneously.
- Be prepared if a fire starts.
- Keep a first aid kit and fire extinguisher handy.
- Keep emergency numbers for doctors, ambulance service, hospital, and fire department near your telephone.

SAFETY

Use Care In Handling and Servicing Batteries

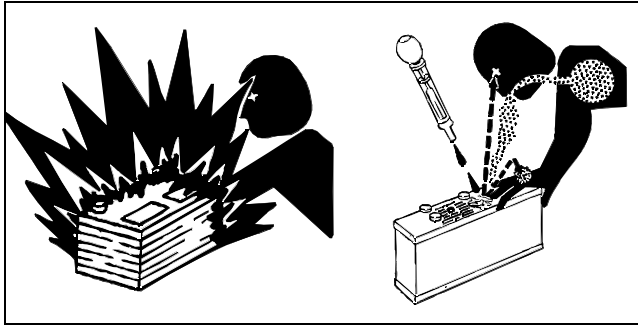

MIF

Prevent Battery Explosions

- Keep sparks, lighted matches, and open flame away from the top of battery. Battery gas can explode.
- Never check battery charge by placing a metal object across the posts. Use a volt-meter or hydrometer.
- Do not charge a frozen battery; it may explode. Warm battery to 16°C (60°F).

Prevent Acid Burns

- Sulfuric acid in battery electrolyte is poisonous. It is strong enough to burn skin, eat holes in clothing, and cause blindness if splashed into eyes.

Avoid acid burns by:

- Filling batteries in a well-ventilated area.
- Wearing eye protection and rubber gloves.
- Avoiding breathing fumes when electrolyte is added.
- Avoiding spilling or dripping electrolyte.
- Use proper jump start procedure.

If you spill acid on yourself:

- Flush your skin with water.
- Apply baking soda or lime to help neutralize the acid.
- Flush your eyes with water for 10 - 15 minutes.
- Get medical attention immediately.

If acid is swallowed:

- Drink large amounts of water or milk.
- Then drink milk of magnesia, beaten eggs, or vegetable oil.
- Get medical attention immediately.

Wear Protective Clothing

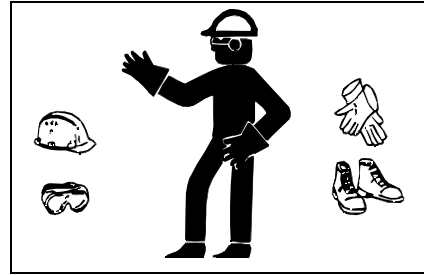

MIF

Wear close fitting clothing and safety equipment appropriate to the job.

Prolonged exposure to loud noise can cause impairment or loss of hearing. Wear a suitable hearing protective device such as earmuffs or earplugs to protect against objectionable or uncomfortable loud noises.

Operating equipment safely requires the full attention of the operator. Do not wear radio or music headphones while operating machine.

Use Care Around High-pressure Fluid Lines

Avoid High-Pressure Fluids

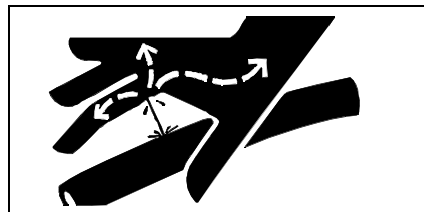

MIF

Escaping fluid under pressure can penetrate the skin causing serious injury.

Avoid injury from escaping fluid under pressure by stopping the engine and relieving pressure in the system before disconnecting or connecting hydraulic or other lines. Tighten all connections before applying pressure.

Search for leaks with a piece of cardboard. Protect hands and body from high pressure fluids.

If an accident occurs, see a doctor immediately. Any fluid injected into the skin must be surgically removed within a few hours or gangrene may result. Doctors unfamiliar with this type of injury should reference a knowledgeable medical source. Such information is available from Deere & Company Medical Department in Moline, Illinois, U.S.A.

SAFETY

Avoid Heating Near Pressurized Fluid Lines



MIF

Flammable spray can be generated by heating near pressurized fluid lines, resulting in severe burns to yourself and bystanders. Do not heat by welding, soldering, or using a torch near pressurized fluid lines or other flammable materials. Pressurized lines can be accidentally cut when heat goes beyond the immediate flame area.

Parking Safely

1. Stop machine on a level surface, not on a slope.
2. Disengage PTO and stop attachments.
3. Lower attachments to the ground.
4. Lock park brake.
5. Stop engine.
6. Remove key.
7. Wait for engine and all moving parts to stop before you leave the operator's station.
8. Close fuel shut-off valve, if your machine is equipped.

Service Machines Safely

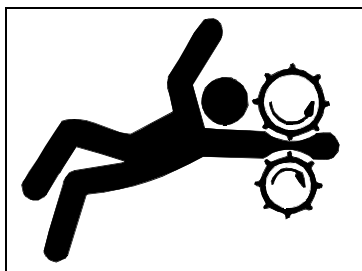

MIF

Tie long hair behind your head. Do not wear a necktie, scarf, loose clothing, or necklace when you work near machine tools or moving parts. If these items were to get caught, severe injury could result.

Remove rings and other jewelry to prevent electrical shorts and entanglement in moving parts.

Service Cooling System Safely

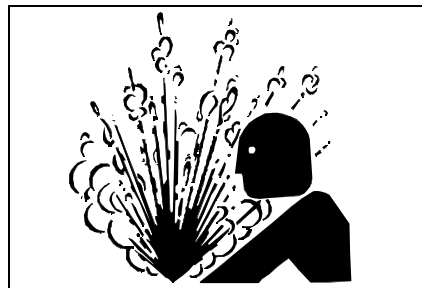

MIF

Explosive release of fluids from pressurized cooling system can cause serious burns.

Shut off machine. Only remove filler cap when cool enough to touch with bare hands. Slowly loosen cap to first stop to relieve pressure before removing completely.

Use Proper Tools

Use tools appropriate to the work. Makeshift tools and procedures can create safety hazards. Use power tools only to loosen threaded parts and fasteners. For loosening and tightening hardware, use the correct size tools. **DO NOT** use U.S. measurement tools on metric fasteners. Avoid bodily injury caused by slipping wrenches. Use only service parts meeting John Deere specifications.

Work in Clean Area

Before starting a job:

1. Clean work area and machine.
2. Make sure you have all necessary tools to do your job.
3. Have the right parts on hand.
4. Read all instructions thoroughly; do not attempt shortcuts.

SAFETY

Support Machine Properly and Use Proper Lifting Equipment

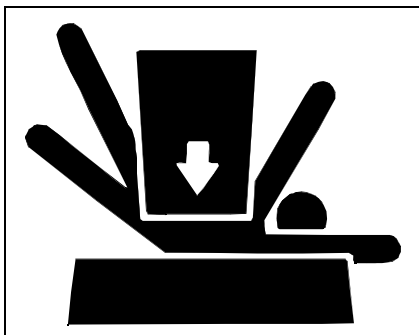

MIF

If you must work on a lifted machine or attachment, securely support the machine or attachment.

Do not support the machine on cinder blocks, hollow tiles, or props that may crumble under continuous load. Do not work under a machine that is supported solely by a jack. Follow recommended procedures in this manual.

Lifting heavy components incorrectly can cause severe injury or machine damage. Follow recommended procedure for removal and installation of components in the manual.

Using High Pressure Washers

Directing pressurized water at electronic/electrical components or connectors, bearings, hydraulic seals, fuel injection pumps or other sensitive parts and components may cause product malfunctions. Reduce pressure and spray at a 45 to 90 degree angle.

Illuminate Work Area Safely

Illuminate your work area adequately but safely. Use a portable safety light for working inside or under the machine. Make sure the bulb is enclosed by a wire cage. The hot filament of an accidentally broken bulb can ignite spilled fuel or oil.

Work In Ventilated Area

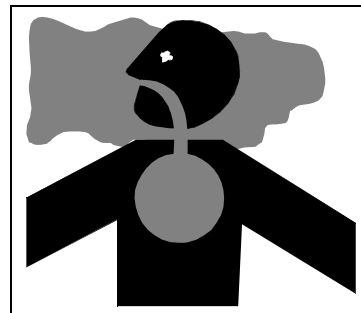

MIF

Engine exhaust fumes can cause sickness or death. If it is necessary to run an engine in an enclosed area, remove the exhaust fumes from the area with an exhaust pipe extension.

If you do not have an exhaust pipe extension, open the doors and get outside air into the area.

Warning: California Proposition 65 Warning

Gasoline engine exhaust from this product contains chemicals known to the State of California to cause cancer, birth defects, or other reproductive harm.

Diesel engine exhaust and some of its constituents are known to the State of California to cause cancer, birth defects, and other reproductive harm.

Remove Paint Before Welding or Heating

Avoid potentially toxic fumes and dust. Hazardous fumes can be generated when paint is heated by welding, soldering, or using a torch. Do all work outside or in a well ventilated area. Dispose of paint and solvent properly. Remove paint before welding or heating: If you sand or grind paint, avoid breathing the dust. Wear an approved respirator. If you use solvent or paint stripper, remove stripper with soap and water before welding. Remove solvent or paint stripper containers and other flammable material from area. Allow fumes to disperse at least 15 minutes before welding or heating.

Avoid Harmful Asbestos Dust

Avoid breathing dust that may be generated when handling components containing asbestos fibers. Inhaled asbestos fibers may cause lung cancer.

Components in products that may contain asbestos fibers are brake pads, brake band and lining assemblies, clutch plates, and some gaskets. The asbestos used in these components is usually found in a resin or sealed in some way. Normal handling is not hazardous as long as airborne dust containing asbestos is not generated.

SAFETY

Avoid creating dust. Never use compressed air for cleaning. Avoid brushing or grinding material containing asbestos. When servicing, wear an approved respirator. A special vacuum cleaner is recommended to clean asbestos. If not available, apply a mist of oil or water on the material containing asbestos. Keep bystanders away from the area.

Service Tires Safely

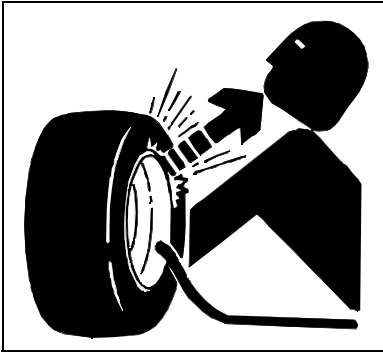

MIF

Explosive separation of a tire and rim parts can cause serious injury or death.

Do not attempt to mount a tire unless you have the proper equipment and experience to perform the job.

Always maintain the correct tire pressure. Do not inflate the tires above the recommended pressure. Never weld or heat a wheel and tire assembly. The heat can cause an increase in air pressure resulting in a tire explosion. Welding can structurally weaken or deform the wheel.

When inflating tires, use a clip-on chuck and extension hose long enough to allow you to stand to one side and NOT in front of or over the tire assembly. Use a safety cage if available.

Check wheels for low pressure, cuts, bubbles, damaged rims or missing lug bolts and nuts.

Avoid Injury From Rotating Blades and Augers

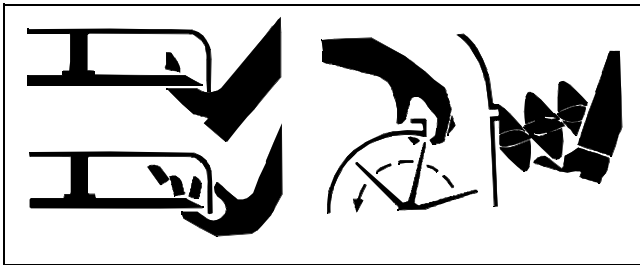

MIF

Keep hands and feet away while machine is running. Shut off power to service, lubricate or remove mower blades, augers or PTO shafts.

Handle Chemical Products Safely

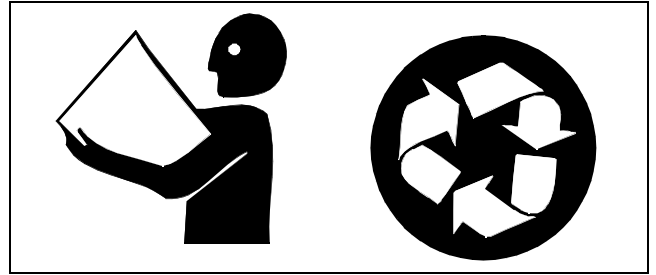

MIF

Direct exposure to hazardous chemicals can cause serious injury. Potentially hazardous chemicals used with John Deere equipment include such items as lubricants, coolants, paints, and adhesives.

A Material Safety Data Sheet (MSDS) provides specific details on chemical products: physical and health hazards, safety procedures, and emergency response techniques. Check the MSDS before you start any job using a hazardous chemical. That way you will know exactly what the risks are and how to do the job safely. Then follow procedures and recommended equipment.

Dispose of Waste Properly

Improperly disposing of waste can threaten the environment and ecology. Potentially harmful waste used with John Deere equipment include such items as oil, fuel, coolant, brake fluid, filters, and batteries. Use leakproof containers when draining fluids. Do not use food or beverage containers that may mislead someone into drinking from them. Do not pour waste onto the ground, down a drain, or into any water source. Inquire on the proper way to recycle or dispose of waste from your local environmental or recycling center, or from your John Deere dealer.

Live with Safety



MIF

Before returning machine to customer, make sure machine is functioning properly, especially the safety systems. Install all guards and shields.

ENGINE - DIESEL DIAGNOSTICS

System: Check for Head Gasket Failures

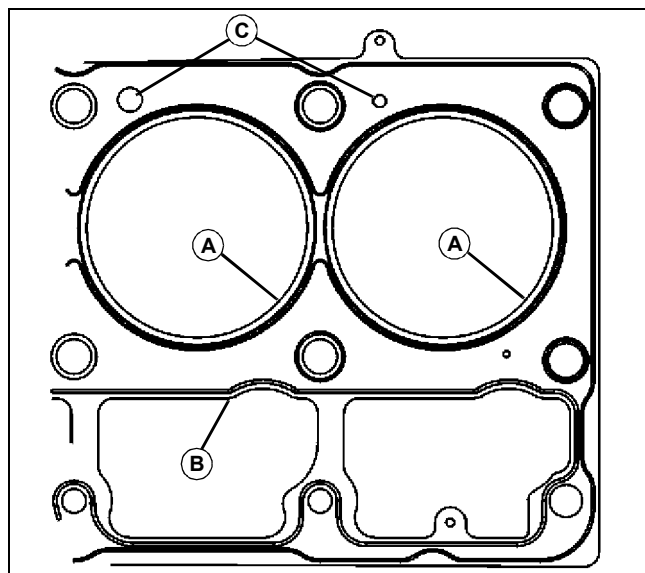

MX33040

Diagnosing Head Gasket Joint Failures

- A- Combustion Sealing Area
- B- Oil Sealing Areas
- C- Coolant Sealing Areas

Head gasket failures generally fall into three categories:

1. Combustion seal failures.
2. Coolant seal failures.
3. Oil seal failures.

Combustion seal failures occur when combustion gases escape between the cylinder head and head gasket combustion flange, or between the combustion flange and cylinder bore. Leaking combustion gases may vent to an adjacent cylinder, to a coolant or oil passage, or externally.

Coolant or oil seal failures occur when oil or coolant escapes between the cylinder head and gasket body, or between the cylinder block and gasket body. The oil or coolant may leak to an adjacent coolant or oil passage, or externally. Since oil and coolant passages are primarily on right-hand (camshaft) side of engine, fluid leaks are most likely to occur in that area.

Follow these diagnostic procedures when a head gasket joint failure occurs or is suspected.

1. Before starting or disassembling engine, conduct a visual inspection of machine and note any of the following:
 - a. Oil or coolant in head gasket seam, or on adjacent surfaces.
 - b. Displacement of gasket from normal position.
 - c. Discoloration or soot from combustion gas leakage.

- d. Leaking radiator, overflow tank, or hoses.
 - e. Leaking coolant from coolant pump weep hole.
 - f. Damaged or incorrect radiator, fan, or shroud.
 - g. Obstructed air flow or coolant flow.
 - h. Worn or slipping belts.
 - i. Damaged or incorrect pressure cap.
 - j. Presence of oil in coolant.
 - k. Low coolant levels or improper coolant.
 - l. Unusually high or low oil levels.
 - m. Oil degradation, dilution, or contamination.
 - n. Indications of fuel or timing adjustments.
 - o. Unburned fuel or coolant in exhaust system.
2. Obtain coolant and oil samples for further analysis.
 3. Start and warm up engine if it can be safely operated. Examine all potential leakage areas again as outlined previously. Using appropriate test and measurement equipment, check for the following:

- a. White smoke, excessive raw fuel, or moisture in exhaust system.
 - b. Rough, irregular exhaust sound, or misfiring.
 - c. Air bubbles, gas trapped in radiator/overflow tank.
 - d. Loss of coolant from overflow.
 - e. Excessive cooling system pressure.
 - f. Coolant overheating.
 - g. Low coolant flow.
4. Shut engine down. Recheck crankcase, radiator, and overflow tank for any significant differences in fluid levels, viscosity, or appearance.
 5. Compare your observations from above steps with the diagnostic charts earlier in this group. If diagnostic evaluations provide conclusive evidence of combustion gas, coolant, or oil leakage from head gasket joint, the cylinder head must be removed for inspection and repair of gasket joint components.

Combustion Seal Leakage:

Symptoms:

1. Exhaust from head gasket crevice
2. Air bubbles in radiator/overflow tank
3. Coolant discharge from overflow tube
4. Engine overheating
5. Power loss
6. Engine runs rough
7. White exhaust smoke

ENGINE - DIESEL DIAGNOSTICS

8. Gasket section dislodged, missing (blown)
9. Coolant in cylinder
10. Coolant in crankcase oil
11. Low coolant level
6. Damage/voids in elastomer beading

Possible Causes:

1. Low head bolt clamping loads
2. Cracked/deformed gasket combustion flange
3. Out-of-flat/damaged/rough cylinder head surface
4. Missing/mislocated gasket fire ring
5. Excessive fuel delivery
6. Advanced injection pump timing
7. Hydraulic or mechanical disturbance of combustion seal

Note: *Cracked cylinder head or cylinder bores may also allow combustion gas leakage into coolant.*

Coolant Seal Leakage:

Symptoms:

1. Coolant discharge from head gasket crevice
2. Coolant in crankcase oil
3. Low coolant level
4. High oil level
5. Coolant discharge from crankcase vent

Possible Causes:

1. Low head bolt clamping loads
2. Out-of-flat/damaged/rough block surface
3. Out-of-flat/damaged/rough cylinder head surface
4. Oil or coolant overheating
5. Cracks/creases in gasket body surfaces
6. Damage/voids in elastomer beading

Oil Seal Leakage:

Symptoms:

1. Oil discharge from head gasket crevice
2. Oil in coolant
3. Low crankcase oil level
4. Reduced oil to rocker arms (noisy)

Possible Causes:

1. Low head bolt clamping loads
2. Out-of-flat/damaged/rough block surface
3. Out-of-flat/damaged/rough cylinder head surface
4. Oil or coolant overheating
5. Cracks/creases in gasket body surfaces

ENGINE - DIESEL TESTS AND ADJUSTMENTS

Tests and Adjustments

Check Air Intake System

1. Check condition of air intake hose. Replace hoses that are cracked, split, or otherwise in poor condition.
2. Replace air cleaner primary filter element. Replace secondary element if primary element has holes in it.
3. Check hose clamps for tightness. Replace clamps that cannot be tightened. This will help prevent dust from entering the air intake system, causing serious engine damage.

Check for Intake and Exhaust Restrictions

Low power and excessive black exhaust smoke can be caused by an intake air or exhaust restriction.

1. Inspect the exhaust pipe and muffler for damage or possible restrictions.
2. Inspect the intake piping. Look for collapsed pipes, dented pipes, cracked hose, and loose connections. Replace components as needed.

Fan/Alternator Drive Belt Adjust

Reason:

To keep correct tension on the drive belt to the water pump and alternator. To prevent shortened belt and bearing life.

Equipment:

- JDG529 or JDST28 Belt Tension Gauge
- Straight Edge

Procedure:

1. Park machine safely. See "Parking Safely" in the Safety section.
2. Allow engine to cool.
3. Raise hood.

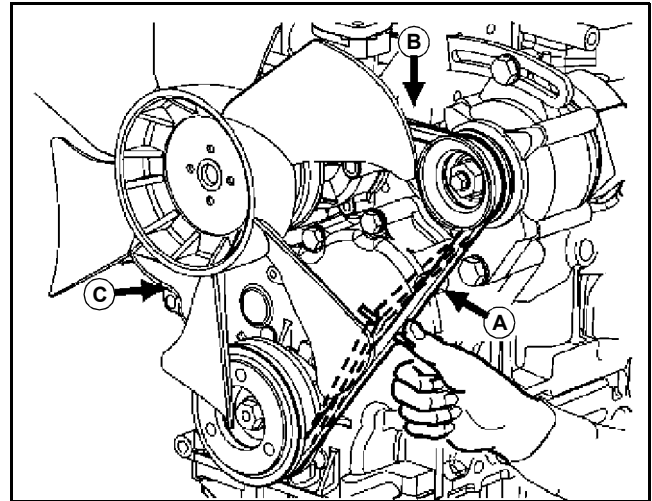

MX32295

4. Apply a force of **98 N (22 lb-force)** to the belt midway between water pump, crankshaft pulley, or alternator (A), (B), or (C) using a belt tension gauge and a straight edge.
5. The deflection should be to specification.

Specifications:

Deflection Point	Used Belt	New Belt
A	10 - 14 mm (0.40 - 0.55 in.)	8 - 12 mm (0.32 - 0.47 in.)
B	7 - 10 mm (0.28 - 0.40 in.)	5 - 8 mm (0.20 - 0.32 in.)
C	9 - 13 mm (0.35 - 0.51 in.)	7 - 11 mm (0.28 - 0.43 in.)

Results:

- If deflection is not within specifications, loosen both alternator mounting cap screws/nuts. Apply force to FRONT alternator housing only (near the belt) until tension is correct. Tighten cap screws/nuts.

ENGINE - DIESEL TESTS AND ADJUSTMENTS

Adjusting Belt Tension

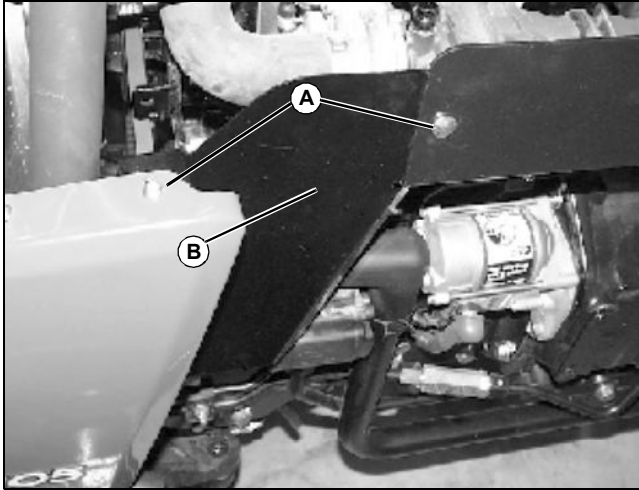

MX39990

1. Remove bolts and nuts (A), and shield (B).

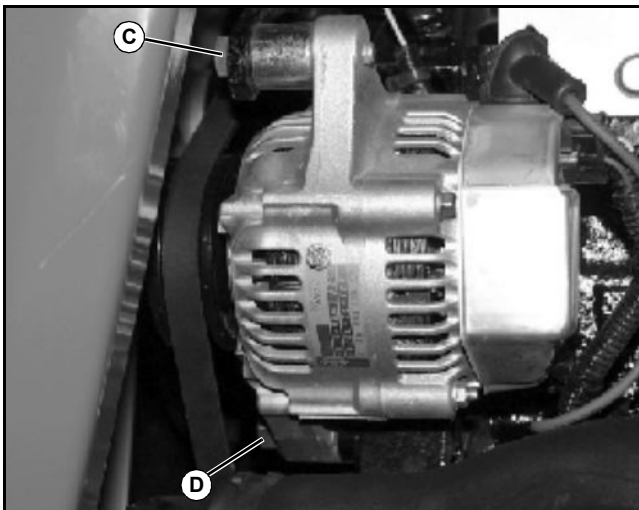

MX39991

2. Loosen adjusting bolt (C).
3. Loosen alternator pivot bolt (D).
4. Move alternator inward to loosen belt, and outward to tighten belt.
5. Tighten bolts to specification.
6. Check belt tension.

Specifications:

Alternator Bolts 40 N•m (30 lb-ft)

Throttle Rod Adjust

Reason:

To ensure that throttle linkage, and foot pedal linkage is adjusted correctly, and allows full high idle and slow idle position of governor throttle lever.

Equipment:

- Metric Wrenches
- Pliers

Procedure:

1. Park machine safely. See "Parking Safely" in the Safety section.
2. Allow engine to cool.
3. Raise hood.
4. Move throttle control lever to high idle position.

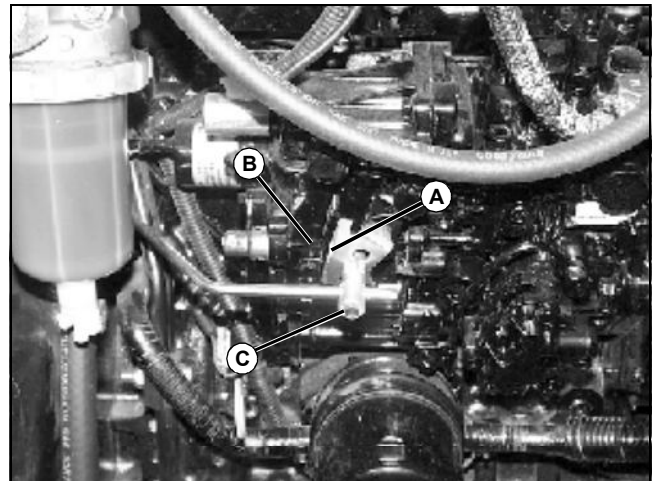

MX39993

5. Injection pump lever (A) should be touching high idle limit screw (B).
6. If not, loosen set screw (C) on throttle rod and adjust rod until throttle lever is touching the stop and there is no excessive strain on the linkage.
7. Hold rod and governor lever in position and tighten set screw.

ENGINE - DIESEL TESTS AND ADJUSTMENTS

Slow Idle Adjust

Important: Avoid Damage! The slow idle adjustment is the only adjustment that can be made on this engine.

The fast idle and torque capsule adjustments are pre-set by the engine manufacturer to comply with strict EPA/CARB emissions requirements, and are adjustable ONLY by authorized diesel service facilities.

Reason:

To achieve proper slow idle rpm setting. Provides adequate rpm to keep the engine running smoothly without stalling.

Equipment:

- JT05719 Hand Held Digital Tachometer

Note: Make sure the air cleaner is clean and not restricted. Replace the air cleaner element as necessary.

Procedure:

1. Park machine safely. See "Parking Safely" in the Safety section.
2. Raise hood.
3. Place a small piece of reflective tape on the crankshaft pulley.
4. Start the engine and run for 5 minutes to attain operating temperature.
5. Move the throttle lever to slow idle position.
6. Use JT05719 Hand Held Digital Tachometer to check engine speed at the crankshaft pulley.

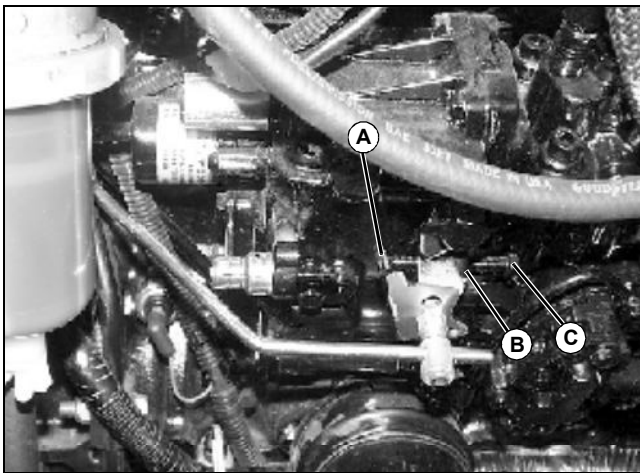

7. Visually check that the injection pump lever (A) is against slow idle stop screw. Slow idle speed is set to specification.

Results:

- If the slow idle rpm is not according to specifications, loosen jam nut (B). Turn the slow idle stop screw (C) to increase or decrease the engine speed until the slow idle speed is correct. Tighten jam nut after adjustment.

Specification:

Slow Idle 950 ± 50 rpm

Thermostat Opening Test

Reason:

To determine opening temperature of thermostat.

Equipment:

- Thermometer
- Glass Container
- Heating Unit

Procedure:

1. Park machine safely. See "Parking Safely" in the Safety section.
2. Allow engine to cool.
3. Raise hood.
4. Remove thermostat. See "Thermostat Remove and Install" on page 72.



Caution: Avoid Injury! DO NOT allow thermostat or thermometer to rest against the side or bottom of glass container when heating water. Either may rupture if overheated.

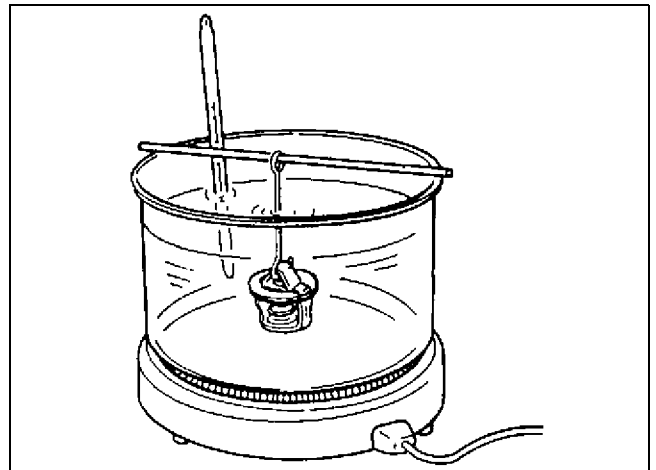

5. Suspend the thermostat and a thermometer in a container of water.
6. Heat and stir the water. Observe opening action of

ENGINE - DIESEL TESTS AND ADJUSTMENTS

thermostat and compare temperatures with specifications.

7. Remove the thermostat and observe the closing action as it cools.

Results:

- If thermostat does not open according to specifications, replace.
- If closing action is not smooth and slow, replace thermostat.

Specifications:

Begin Opening 69.5 - 72.5° C (157 - 163° F)

Fully Open 85° C (185° F)

Minimum Lift Height Above 85° C (185° F). 8 mm (0.315 in.)

Cylinder Compression Test

Reason:

To determine the condition of the pistons, rings, cylinder walls and valves.

Equipment:

- JT01682 Compression Gauge Assembly
- JDG560 Adapter

Procedure:

1. Run engine for 5 minutes to bring to operating temperature. Shut off engine.
2. Remove the injection nozzles.

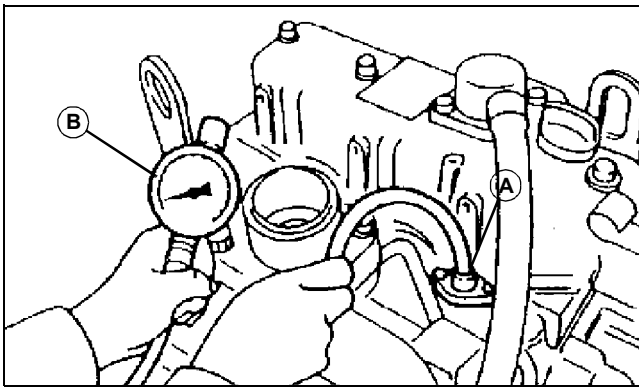

3. Remove the heat protector from end of injector and install JDG560 adapter (A).
4. Install JT01682 Compression Gauge Assembly (B) and JDG560 Adapter.
5. Disconnect the fuel control solenoid connector.

Important: Avoid Damage! DO NOT overheat starting motor during test.

6. Crank the engine for five seconds with the starting motor. Minimum cranking speed is 250 rpm.

7. Record the pressure reading for each cylinder.

Specifications:

Difference Between Cylinders (maximum) . . . 200 - 300 kPa (29 - 43 psi)

Minimum Cranking Speed 250 rpm

Results:

- If pressure reading is below specification, squirt clean engine oil into cylinders through injector ports and repeat test.
- If pressure increases significantly, check piston, rings, and cylinder walls for wear or damage.
- If pressure does not increase significantly after retest, check for leaking valves, valve seats or cylinder head gasket.

Valve Clearance Adjust

Reason:

To maintain proper clearance between valves and rocker arms for maximum compression and valve train life.

Equipment:

- Feeler Gauge
- 10 mm End Wrench
- Flat Blade Screwdriver
- 17 mm Wrench

Procedure:

1. Park machine safely. See "Parking Safely" in the Safety section.
2. Raise hood.
3. The engine must be cool (room temperature) before the valve clearance is checked.
4. Be sure ignition key is OFF before attempting to turn engine by hand.
5. Remove the rocker arm cover. See "Rocker Cover Remove and Install" on page 82.

Note: "Top dead center (TDC)" is when the number one piston is at its highest point of travel in the cylinder on the compression stroke. Number one cylinder is located at rear of engine (flywheel side).

ENGINE - DIESEL TESTS AND ADJUSTMENTS

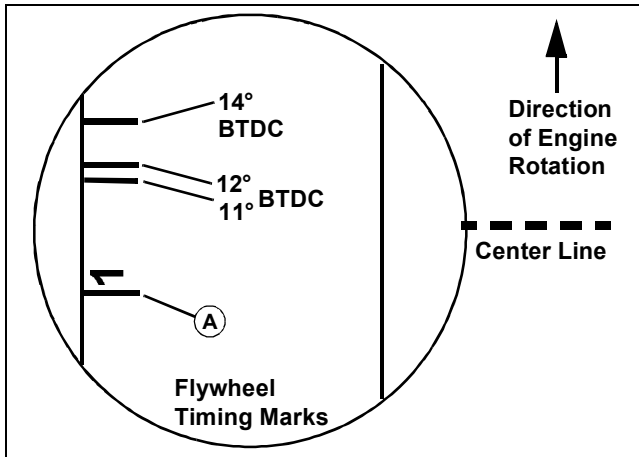

MIF

6. Locate the inspection hole in right side of the flywheel housing. The flywheel can be seen inside the inspection hole.

Note: When TDC is reached, the rocker arms for that cylinder will be motionless as the crankshaft is rotated. If rocker arms are still moving when TDC is approached, rotate crankshaft one full revolution and try again.

7. Turn the crankshaft pulley while watching the flywheel inside the inspection hole. Align the number one TDC mark (A) on the flywheel with the pointer on the tunnel.

8. Try to move rocker arms and/or push rods for No. 1 cylinder:

- If the rocker arms and push rods are loose, the piston is at TDC of the compression stroke. Go to next step.
- If the rocker arms and/or push rods are not loose, rotate the flywheel one revolution (360°). Recheck the rocker arms and push rods.

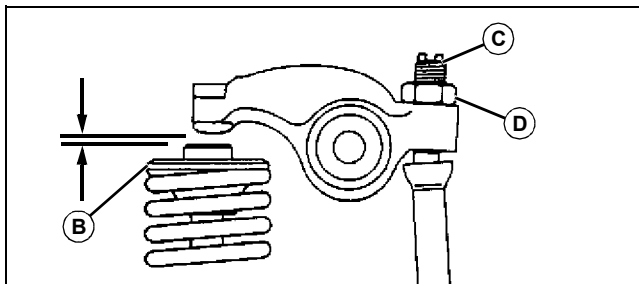

MX1194

9. Slide a feeler gauge between the valve cap (B) and rocker arm to measure the clearance.

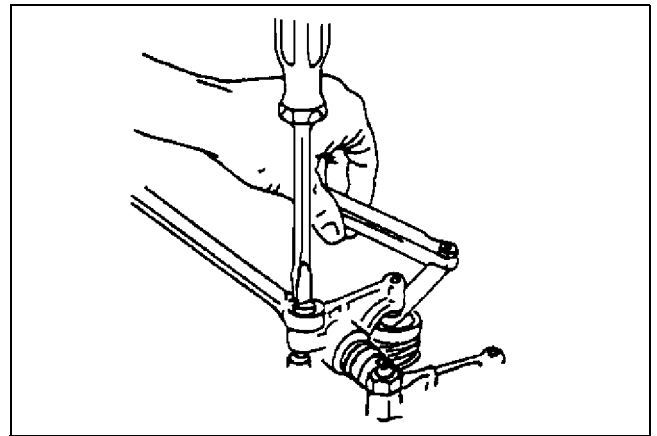

T6105BF

10. To adjust the valves, loosen the lock nut (D). Turn the adjusting screw (C) until the blade of the feeler gauge can be inserted between the rocker arm and valve cap. Hold the adjusting screw while tightening the lock nut.

11. Recheck the valve clearance after tightening the lock nut.

Specification:

Valve Clearance 0.15 - 0.25 mm (0.006 - 0.010 in.)

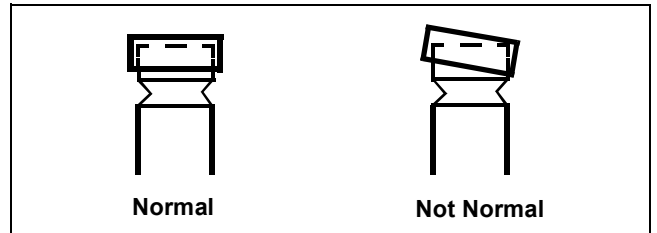

MIF

12. Check that the valve cap on the valve stem remained seated on the valve and inside the valve spring retainer.

13. Turn the crankshaft pulley counter clockwise (as viewed from operator's seat or flywheel end) approximately 2/3 of a revolution (240°) while watching the observation hole for the number three timing mark.

14. Check that the rocker arms and push rods for cylinder number three are loose.

15. Repeat steps 7 - 13 for number three cylinder.

16. Repeat steps 7 - 11 for number two cylinder.

17. Replace the rocker arm cover, air cleaner bracket and housing, and the muffler.

Valve Lift Check

Reason:

To test for excessive wear on camshaft lobes, cam followers, rocker arms, valve stems, valve caps, or bent

ENGINE - DIESEL TESTS AND ADJUSTMENTS

push rods.

Equipment:

- Dial Indicator with magnetic base

Procedure:

1. Park machine safely. See "Parking Safely" in the Safety section.
2. Allow engine to cool.
3. Raise hood.
4. Remove the rocker arm cover. See "Rocker Cover Remove and Install" on page 82.
5. Check that valve clearance is within specification. Adjust if necessary.

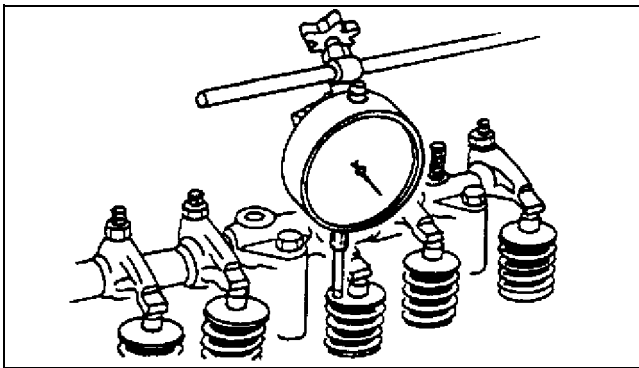

T6333DT

6. Fasten the dial indicator to the engine and position the indicator tip on the valve retainer. The valve must be fully closed and the rocker arm must move freely.
7. Zero the dial indicator.
8. Manually turn the crankshaft pulley clockwise (from the fan end).
9. Observe the dial indicator as the valve is moved to the full open position. Repeat for each valve.

Specification:

Valve Lift 7.5 mm (0.300 in.)

Results:

- If valve lift is less than specification, remove and inspect camshaft, camshaft followers, push rods, valve caps and stems, and/or rocker arms for wear or damage.
- The valve lift should be the same for all valves. If one or more valves have less travel than the others, remove and inspect the camshaft, followers and push rods. See "Camshaft" on page 112. If the camshaft, followers and push rods are within specification remove and inspect the cylinder head. See "Cylinder Head and Valves Remove and Install" on page 95.

Radiator Bubble Test

Reason:

To determine if compression pressure is leaking from combustion cylinder into water jacket.

Equipment:

- JDG560 Adapter

Procedure:

1. With the coolant at the proper level and the radiator cap tight, run the engine for 5 minutes to bring it to operating temperature.
2. Remove the cap from the recovery tank.
3. Check for bubbles coming from the overflow hose at the bottom of the tank.
 - If bubbles are present, isolate the source of the compression leak.
4. Remove the injection nozzles.
5. Install JDG560 Adapter in the injection port of the cylinder to be tested.
6. Move the piston to the bottom of the stroke with intake and exhaust valves closed.
7. Connect the hose from a compressed air source to the adapter.
8. Apply shop air pressure into the cylinder.
9. Check for bubbles in the recovery tank or air escaping from the muffler, air cleaner or oil fill opening.
10. Repeat for each cylinder.

Results:

If bubbles are present:

- Check for cracks in cylinder head and block. Check for damaged head gasket.

If air escapes from muffler:

- Check for worn exhaust valve.

If air escapes from air cleaner:

- Check for worn intake valve.

If air escapes from engine oil fill:

- Check for worn piston rings.

ENGINE - DIESEL TESTS AND ADJUSTMENTS

Radiator Pressure Cap Test

Reason:

Test the radiator cap for operating pressure range.

Equipment:

- D05104ST Cooling System Pressure Pump
- JDG692 Radiator Pressure Test Kit (Adapters)

Procedure:

1. Install the radiator cap on the pressure pump.
2. Apply pressure. Pressure valve in the cap should open at specification.

Results:

- If the cap leaks, retighten and test again. Replace the cap if pressure is not within specification.

Specification:

Opening Pressure. 88 kPa (12.8 psi)

Cooling System Pressure Test

Reason:

Inspect the cooling system for leaks.

Equipment:

- D05104ST Cooling System Pressure Pump
- JDG692 Radiator Pressure Test Kit (Adapters)

Procedure:

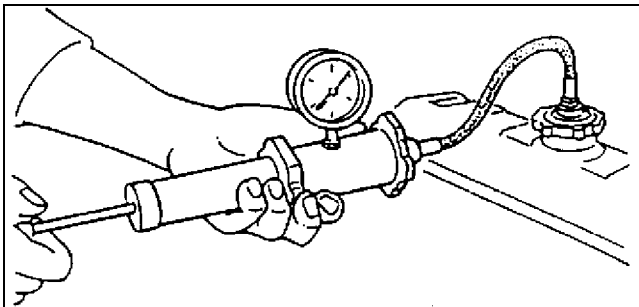

M87350

1. Remove the cap and attach the pressure pump to radiator.
2. Apply pressure to specification.
3. Check for leaks throughout the cooling system. Keep system pressurized for 5 minutes.

Results:

- Pressure should hold at specification. If pressure decreases, check for leaks. Repair leaks or replace parts

as necessary.

- If the pressure test still indicates leakage after all external leaks have been stopped, a defective head gasket, cracked block, or cylinder head may be the cause. See “Radiator Bubble Test” on page 52.

Specification:

Pressure (minimum - maximum) 88 - 97 kPa (12.8 - 14.0 psi)

Engine Oil Pressure Test

Reason:

To determine if engine bearings or lubrication system components are worn.

Equipment:

- JT03017 Hose Assembly
- JT05577 Pressure Gauge (100 psi)
- JT03349 Connector

Procedure:

1. Park machine safely. See “Parking Safely” in the Safety section.
2. Allow engine to cool.
3. Raise hood.

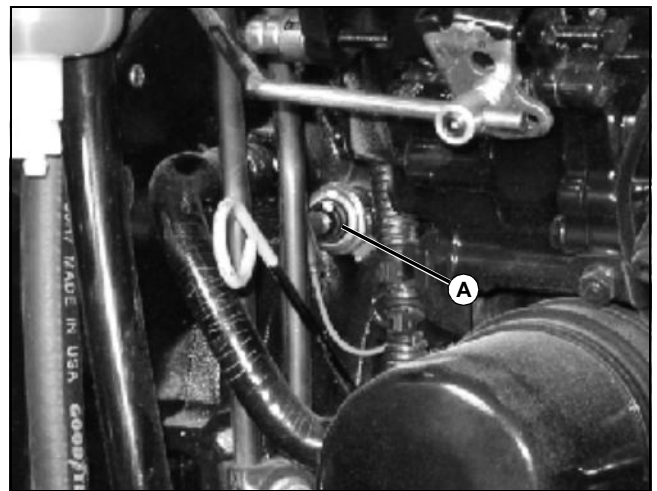

MX34303

4. Remove wire to oil pressure switch (A).
5. Unscrew oil pressure switch from block.
6. Install JT03349 Connector into block.
7. Connect JTO3017 Hose Assembly and JTO5577 Pressure Gauge.

Important: Avoid Damage! Stop running engine if no oil pressure is present.

ENGINE - DIESEL TESTS AND ADJUSTMENTS

8. Start the engine. If pressure reading is below **70 kPa (10 psi)** at slow idle rpm, STOP THE ENGINE.

9. If the oil pressure is at least **70 kPa (10 psi)** run the engine approximately five minutes to heat the oil. Check the oil pressure at **2600 rpm**.

Specification:

High Idle (Rated Speed) . 294 - 392 kPa (42.6 - 56.8 psi)

Slow Idle (Minimum) 70 kPa (10 psi)

Results:

- If the oil pressure is not within specifications, inspect the oil pump and relief valve.
- If the oil pump is within specifications, the engine may have parts worn beyond specifications. See “Engine Troubleshooting” on page 33.

Engine Oil Consumption

All engines consume some oil. The consumption rate depends on loading, design of key parts and engine condition. Since fuel consumption is an indicator of operating power levels, fuel used versus oil consumed is a critical factor in analyzing oil consumption. Oil consumption should be measured over a 100-hour period.

Long-term oil consumption (three oil drain intervals after the engine is broken in) with consumption rates poorer than 400:1 (100 gallons of fuel to 1 quart of oil) indicates a need to monitor/investigate. Suggested steps would be:

1. Check for signs of ingested dust or perform an OILSCAN test to check for silicon.
2. Check for proper crankcase oil fill level.
3. Perform compression test.
4. Remove head. Inspect for glazed or worn cylinder bores.
5. Inspect pistons for carbon deposits in the ring grooves.
6. Measure valve stem OD and valve guide ID to determine clearance.

Note: Ring gap alignment does not identify the leak source.

Intake valves do not have valve stem seals. Some oil deposits on the valve stem tulip are normal.

When changing to a premium oil, little oil consumption change is expected, although some engines will experience a noticeable change in consumption rates. This may be due to the following:

1. The previous oil may have left deposits on internal components. Use of PLUS-50[®] oil will cause different chemical reactions in those deposits. The time required for the engine to regain the previous oil consumption rate will

vary from one to three normal drain intervals.

2. TORQ-GARD SUPREME[®] PLUS-50[®] contains a high-performance anti-oxidant along with other additives resulting in the oil remaining in the specified viscosity grade throughout the recommended drain interval. API oil grades CD, CE, and CF-4 universal engine oils do not provide this oxidation resistance which results in more rapid thickening. Increased oil viscosity can reduce oil consumption.

Fuel System Leakage Test

Reason:

Tests the fuel system plumbing for external leakage. This test also determines if air is entering the fuel system at connections, allowing fuel to siphon back to the tank.

Procedure:

1. Disconnect the fuel supply line and return line at the fuel tank.
2. Place the fuel return line into a suitable container to catch drained fuel.

Important: Avoid Damage! DO NOT apply more than 103 kPa (15 psi) air pressure to the fuel system. Damage to the injection pump or personal injury may result.

3. Apply **34 - 69 kPa (5 - 10 psi)** air pressure to fuel supply hose until all fuel is drained from the system.
4. Plug the end of the fuel return hose.
5. Apply **34 - 69 kPa (5 - 10 psi)** air pressure to the fuel system at the fuel supply line. DO NOT exceed a maximum pressure of **103 kPa (15 psi)**.
6. Apply liquid soap and water solution to all joints and connections in the fuel system. Inspect for leaks.

Results:

- Find leaks. Repair or replace parts as necessary.

Bleed Fuel System

Reason:

The machine incorporates a self bleeding fuel system which forces air out of the fuel filter, injection pump, and injection nozzles, and vents it back to the fuel tank. Fuel system bleeding is usually not necessary after a repair. If the system is completely drained and will not self-prime without overheating the starter, proceed as follows:

1. Park machine safely. See “Parking Safely” in the Safety section.
2. Raise hood.

ENGINE - DIESEL TESTS AND ADJUSTMENTS

3. Assure that all fuel line connections are securely tightened.
4. Be sure fuel tank is not empty, and fuel valve on fuel filter is OPEN ("ON" position).
5. Place the key switch ON for 10 to 15 seconds to allow the electric fuel pump and fuel system to bleed most of the air back to the tank through the return lines.

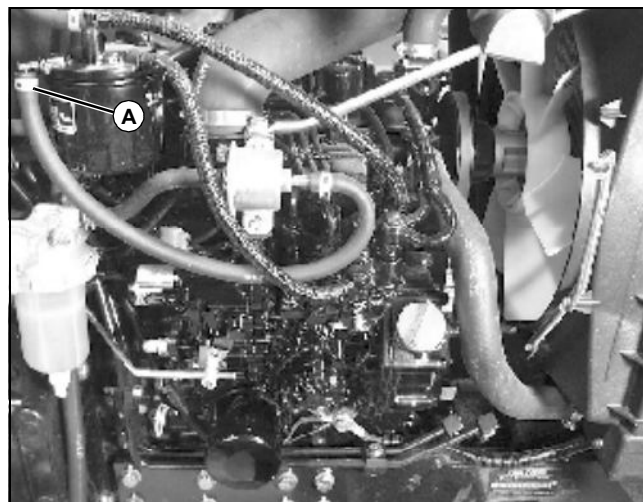
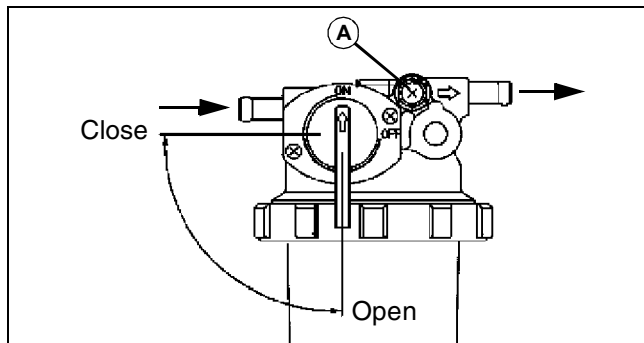

6. If the fuel filters were replaced and/or the fuel lines drained, loosen the air bleeding bolt (A) on the fuel water separator by turning it 2-3 turns.
7. When the fuel comes out clear and does not have bubbles, tighten the air bleeding bolt.

Fuel Supply Pump Pressure Test

Reason:

To determine supply pump operating pressure.

Equipment:

- JDG356 Fuel Pump Pressure Test Kit

Test Conditions:

- Fuel temperature 15° - 25° C (59 - 77° F)

Flow Test:

1. Park machine safely. See "Parking Safely" in the Safety section.
2. Allow engine to cool.
3. Raise hood.
4. Disconnect fuel shutoff solenoid wire.

Note: Do not crank engine for this test. The electric fuel pump operates with the key switch ON.

5. Disconnect fuel supply pump outlet hose (A) from fuel filter. Place end of hose into a clean graduated container.
6. Turn key switch ON for 15 seconds. Collect fuel in graduated container.
7. Compare fuel amount to specification.

Specification:

Fuel Flow in 15 seconds . . . 100 mL (3.4 oz) (minimum)

Pressure Test:

1. Install the hose and gauge to outlet hose (A).
2. Place key switch in ON position.
3. Record fuel pressure reading on gauge.

Results:

- If the pressure does not meet specification, replace the fuel pump.

Specification:

Fuel Pressure (maximum) 37.3 kPa (5.4 psi)

ENGINE - DIESEL TESTS AND ADJUSTMENTS

Injection Pump Timing



Caution: Avoid Injury! DO NOT adjust the fuel injection pump timing. For most engine problems, the fuel injection pump timing will not have to be adjusted. If the engine performed well at one time, then performance dropped, the fuel injection timing is **NOT** the problem.

Fuel injection timing, once set by the engine manufacturer, should **NOT** change during the life of the engine.

Important: Avoid Damage! Fuel injection pump timing should **NOT** change during the life of the engine unless the pump has been altered illegally, or there is excessive wear to the injection pump camshaft lobes and lifters.

First check the fuel quality, fuel supply, fuel injectors, air intake system, and engine compression in all cylinders before considering fuel injection timing problems.

If all other possibilities have been ruled out and it is determined that the fuel injection pump and governor assembly are in need of repair, they must be replaced **ONLY** as complete assemblies.

Only an authorized factory trained technician is allowed to remove and install these assemblies.

Equipment:

Special or Required Tools

Tool Name	Tool No.	Tool Use
Yanmar TNV Diesel Engine Timing Tool Kit	JDG10436	Adjust Injector Pump Timing.

Checking Fuel Injection Timing:

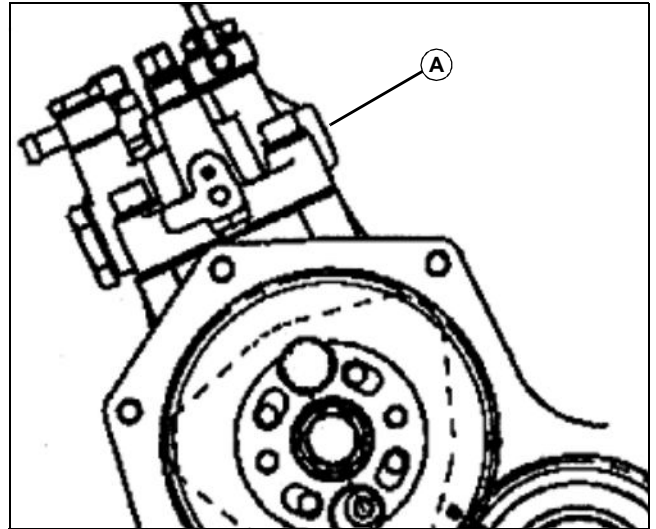

MX39096

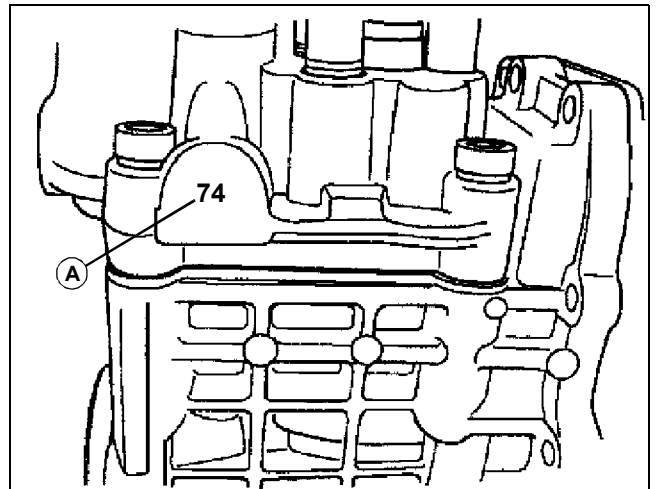

MX40237

1. Locate and record the fuel injection pump timing index number stamped on the boss (A) of the engine side of the fuel injection pump housing. Treat this number as though there is a decimal point between the two digits. i.e. 74 = 7.4.

2. The Fuel Injection Reference (FIR) number for the 4105 is shown below. Record the number.

ENGINE - DIESEL TESTS AND ADJUSTMENTS

John Deere Model	Yanmar Engine Model	FIR (Fuel Injection Reference Number)
4105	3TNV84T-BKJT	4.0

- Insert the numbers you have recorded into the following equation:

(Fuel Injection Pump Timing Index Number X2) + FIR Number = FIT° (Fuel Injection Timing in Degrees)

Example: Fuel Injection Pump Timing Index Number is 74. Add decimal point, number is now 7.4 X2 = 14.8 + FIR number of 4.0 = 18.8° FIT° (Fuel Injection Timing in Degrees) BTDC

3. Turn off the fuel valve and clamp the fuel return hose shut.

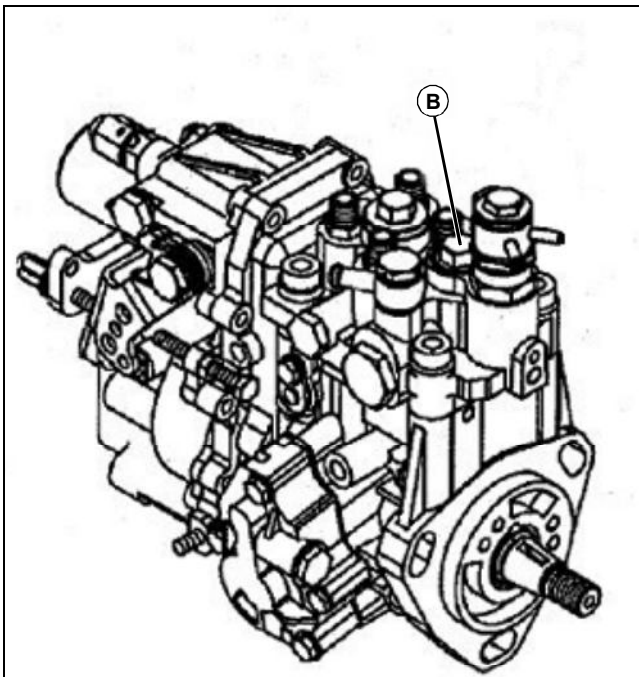

MX39089

4. Clean the top of the injector pump to prevent dirt from entering the pump when plunger plug is removed. Remove the forward fuel injection pump plunger plug (B) on top of the fuel injection pump.

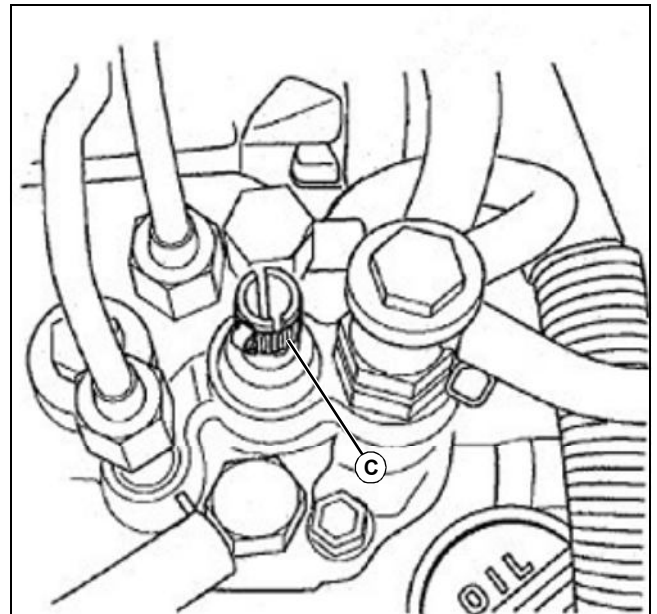

MX39090

5. Install a dial indicator adapter (C) and clamp from the JDG10436 timing tool kit into the pump plunger opening.

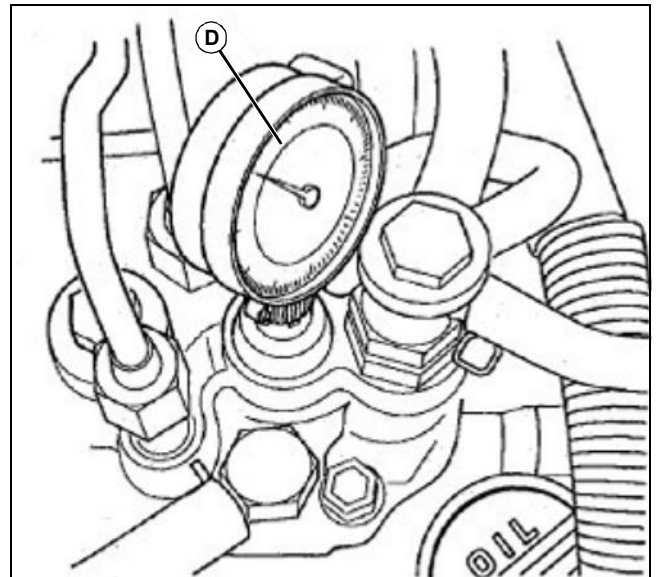

MX39091

6. Install the dial indicator (D) with extension into the adapter. Move the indicator up and down while watching the dial. When the dial gets to the midway point of travel, tighten clamp.

Note: The following references to rotating the crankshaft are from the coolant pump end of the engine and are adjusted by turning the crankshaft pulley.

ENGINE - DIESEL TESTS AND ADJUSTMENTS

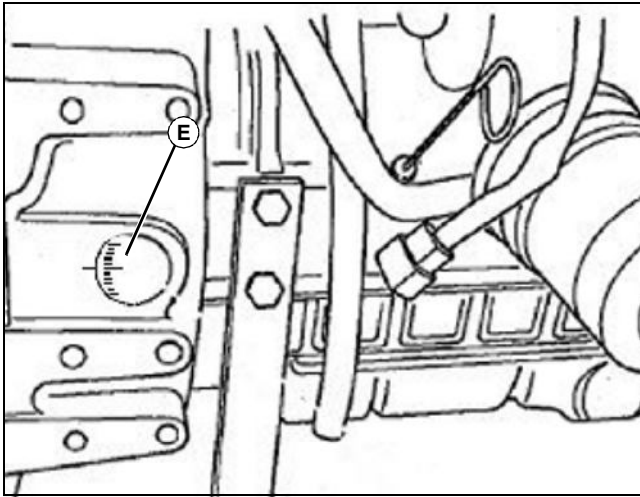

MX39093

7. Using a wrench on the crankshaft pulley bolt, rotate the crankshaft in a clockwise direction while looking through the flywheel inspection port (E).

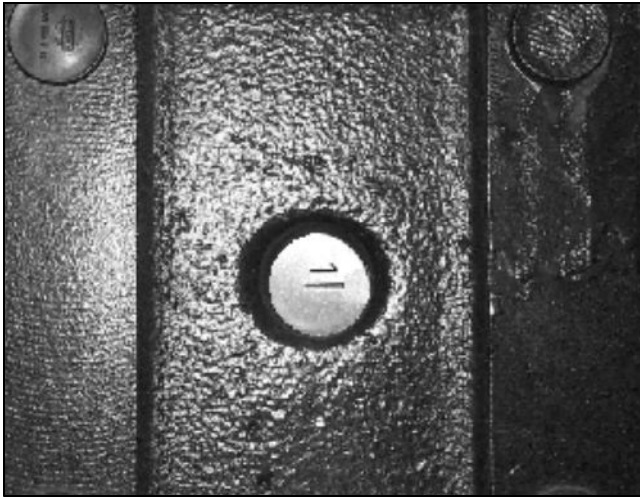

MX40480

Shows number 1 Cylinder TDC mark

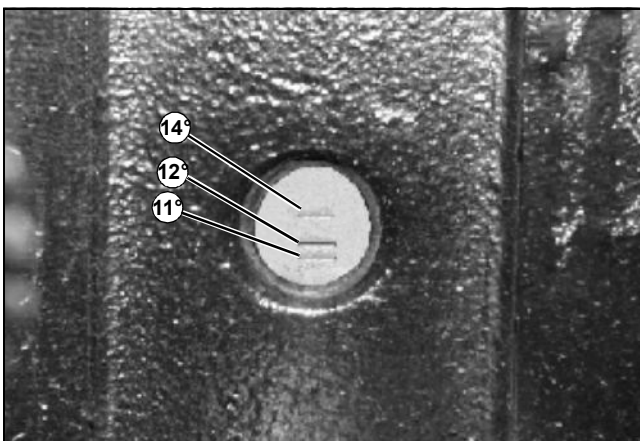

MX40481

Shows injection timing marks in degrees BTDC on engines up to May of 2008.

8. Rotate the crankshaft until the injection timing marks are visible.

Note: A typical flywheel will have a timing mark grid for each cylinder. Any grid can be used to check the fuel injection timing. Flywheels on machines made after May 2008 shown in MX40499 above have marks for every degree from 10 to 20. On these flywheels highlight the calculated (target) timing mark and proceed to step 10.

Flywheels on machines made before May 2008 do not have marks for every degree. On the pre May 2008 flywheel shown in MX40481 the pair of marks above the TDC mark are 11 and 12° BTDC and the next mark up is 14°. As calculated earlier the timing should be 18.8° BTDC. Timing specs are to $\pm 1^\circ$ so if your calculation has a decimal point, round it up or down to the nearest degree. In this case round it up to 19°.

If the timing calculations on your engine do not coincide with the marks stamped in the flywheel you must determine where the calculated BTDC mark should be and mark the flywheel. This particular engine does not have a mark at 19° so you will have to determine where the 19° BTDC mark should be and place the mark on the flywheel. Timing marks are more easily accessed from bottom of flywheel housing. Turn the flywheel to access the marks. The 14° mark is shown below. One degree on the flywheel is 2.9 mm, so you need to add a mark (A) $5 \times 2.9\text{mm} = 14.9\text{mm}$ to the right of the 14° mark to be at 19° BTDC.

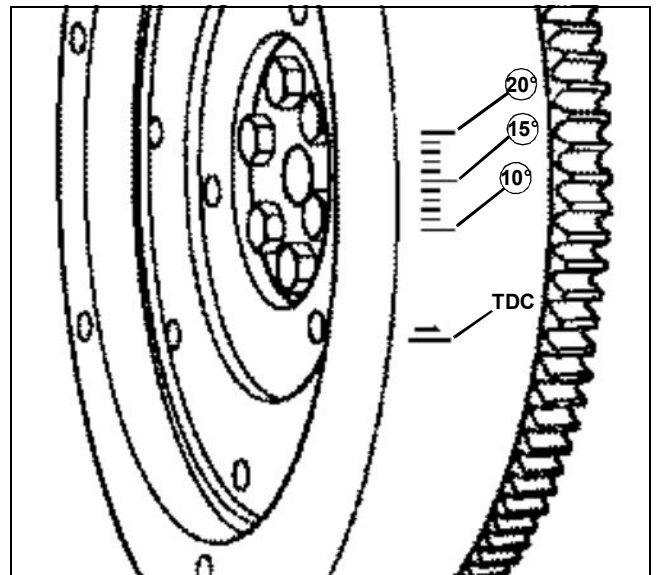

MX40499

Shows injection timing marks in degrees BTDC on engines after May 2008



Download the full PDF manual instantly.

Our customer service e-mail:

aservicemanualpdf@yahoo.com