

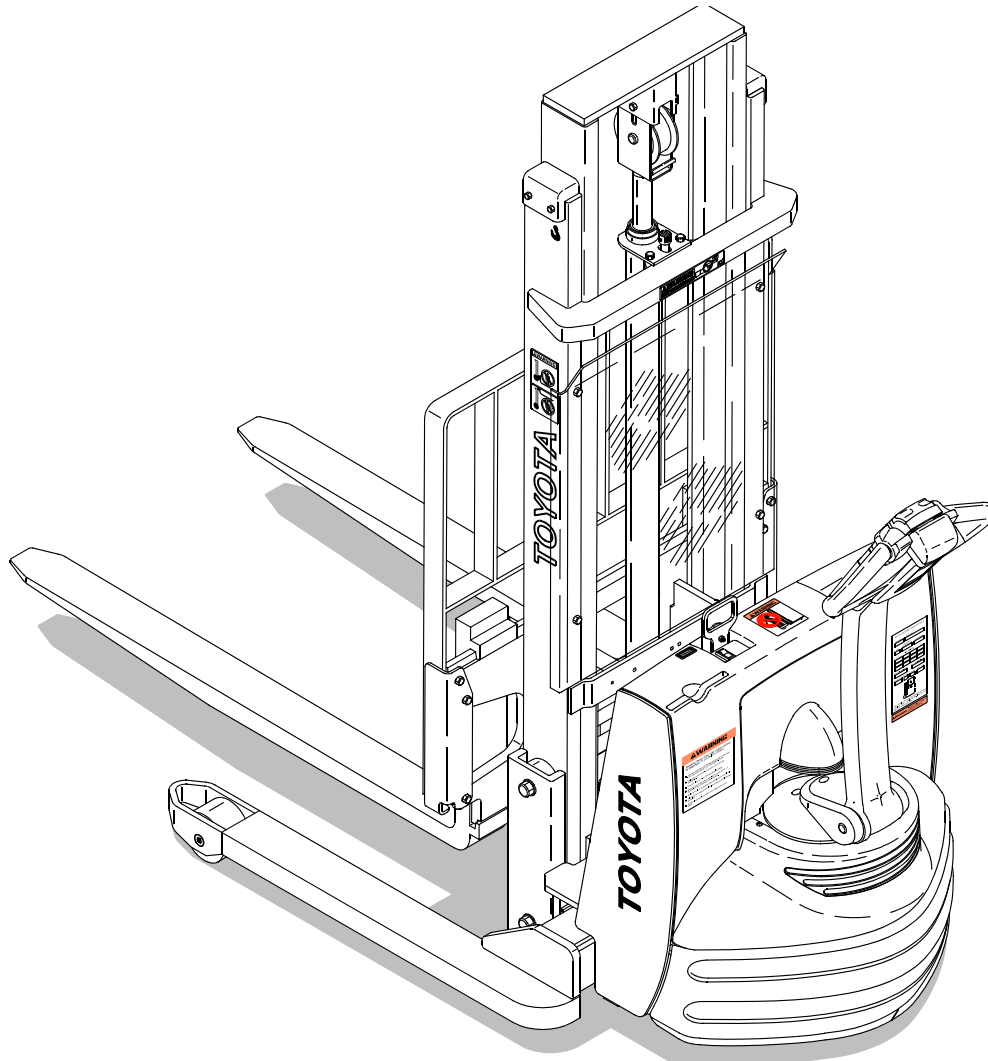

## 7BWS10/13

Electric Walkie Low-Lift Pallet Truck  
Effective Serial Number 40500 - UP



-  **Warning** Read and observe all warnings on this unit before operating it.
-  **Warning** **DO NOT** operate this equipment unless all factory installed guards and covers are properly secured in place.

**Ordering Spare Parts**

## Ordering Spare Parts

Supply the following information will assure prompt, efficient handling of the order:

1. Identify truck model and serial number.
2. Refer to Parts Book and locate page with the exploded diagram.
3. Find item number for the part required. Select the column for the actual truck model and serial number.
4. The following is an explanation of a serial number:

**7BWS10 40500**

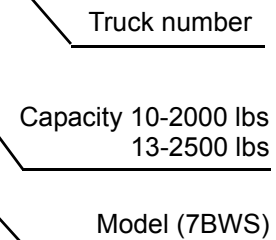

**CAUTION** Although some trucks appear to be similar, component parts may not be interchangeable. If an incorrect part is used, the truck may malfunction.

5. Note part number.
6. Call your local **Toyota Dealer** and state part number.
7. If the truck model, serial number, or article number cannot be found on the truck, call your local **Toyota Dealer** for assistance.

## Table of Contents

<b>Ordering Spare Parts .....</b>	<b>1</b>
<b>Standard Codes .....</b>	<b>11</b>
<b>Warning Symbols .....</b>	<b>13</b>
Warning Levels .....	13
<b>Prohibitory Symbols .....</b>	<b>14</b>
Ordinance Symbols .....	14
<b>Safety .....</b>	<b>15</b>
General Safety .....	15
<b>Battery Safety .....</b>	<b>20</b>
<b>Static Discharge Precautions .....</b>	<b>25</b>
<b>Welding Safety .....</b>	<b>27</b>
<b>Introduction, Service Manual .....</b>	<b>29</b>
<b>Contents, Section M .....</b>	<b>31</b>
Machine Information .....	31
<b>General Product Information .....</b>	<b>33</b>
Truck Presentation .....	33
Truck Side Views .....	33
Intended Truck Application .....	33
Prohibited Truck Application .....	34
Truck Data .....	34
Dimensions .....	35
Data Plate .....	36
Main Components .....	37
<b>Inch (SAE) and Metric Fasteners .....</b>	<b>39</b>
Introduction .....	39
Nomenclature, Threads .....	40
Strength Identification .....	41
Truck Torque Specifications .....	47
Conversion of Metric and English Units .....	48
<b>Technical Service Data .....</b>	<b>51</b>
<b>Contents, Section P .....</b>	<b>55</b>
Planned Maintenance .....	55
<b>Introduction, Maintenance .....</b>	<b>57</b>
Jacking Truck Off The Floor .....	58

## Table of Contents

Elevate Rear of Truck .....	58
Elevate Either Side of Truck .....	59
Lubricants .....	59
Standard .....	59
<b>Service Schedule .....</b>	<b>61</b>
Planned Maintenance Schedule .....	61
Planned Maintenance Procedures .....	65
General .....	65
Hardware .....	65
Noise .....	65
Leaks .....	65
Cables and Connections .....	66
Grease Location Points .....	66
Services Performed Daily or Every 8 Operating Hours .....	66
Chassis .....	66
Brakes .....	66
Wheels/Tires .....	66
Tiller Arm .....	66
Functions/Operations .....	67
Battery .....	67
Battery Connector .....	67
Services Performed Every Six Months or 500 Operating Hours Under Moderate Usage or Three Months or 250 Hours Under Severe Usage .....	68
Chassis .....	68
Motors .....	68
Drive Unit .....	68
Brake .....	68
Electrical Control System .....	69
Battery .....	69
Electrical Panel .....	69
Hydraulic System .....	69
Mast .....	69
Lifting Devices .....	69
Services Performed 12 Months or Every 1000 Operating Hours Under Moderate Usage and Six Months or Every 500 Operating Hours Under Severe Usage .....	70
Drive Unit .....	70
Hydraulic System .....	70
<b>Lubrication Chart .....</b>	<b>71</b>
<b>Oil and Grease Specifications .....</b>	<b>72</b>
Lubricants .....	72
Grease Location Points .....	72
<b>Contents, Section S .....</b>	<b>73</b>
Service Instructions .....	73
<b>Stabilizer Support Arms .....</b>	<b>75</b>
Theory of Operation .....	76
Maintenance .....	76

## Table of Contents

Support Arm Width Adjustment .....	76
<b>Inspection, Covers .....</b>	<b>81</b>
Theory of Operation .....	82
Maintenance .....	82
Troubleshooting .....	82
Repair and Rebuild .....	82
<b>Decals .....</b>	<b>83</b>
Decal with Protective Sheet .....	83
Decal without Protective Sheet .....	83
<b>Electric Motors .....</b>	<b>85</b>
Theory of Operation .....	85
Maintenance .....	85
Troubleshooting .....	86
Repair and Rebuild .....	87
Pump Motor .....	87
Removal .....	88
Installation .....	89
Drive Motor .....	90
Brush Inspection and Replacement .....	90
Brush Inspection .....	90
Brush Replacement .....	92
Motor Disassembly .....	93
Motor Assembly .....	94
<b>Transmission .....</b>	<b>99</b>
Theory of Operation .....	101
Maintenance .....	101
Fluid Changing .....	101
Troubleshooting .....	102
Repair and Rebuild .....	104
<b>Parking Brake System .....</b>	<b>111</b>
Theory of Operation .....	112
Maintenance .....	114
Mechanical Brake Release .....	114
Brake Adjustment .....	114
Troubleshooting .....	115
Repair and Rebuild .....	116
<b>Drive Wheel .....</b>	<b>117</b>
Theory of Operation .....	117
Maintenance .....	118
Drive Wheel Nut Inspection .....	118
Troubleshooting .....	120
Repair and Rebuild .....	121
<b>Load Wheels .....</b>	<b>125</b>

## Table of Contents

Theory of Operation .....	126
Maintenance .....	126
Troubleshooting .....	126
Repair and Rebuild .....	126
<b>Tiller Arm Handle .....</b>	<b>129</b>
Theory of Operation .....	131
Maintenance .....	131
Inspection .....	131
Troubleshooting .....	131
Repair and Rebuild .....	132
<b>Tiller Arm Head .....</b>	<b>135</b>
Theory of Operation .....	137
Maintenance .....	137
Troubleshooting .....	137
Repair and Rebuild .....	137
<b>Steering Bearing .....</b>	<b>139</b>
Theory of Operation .....	140
Maintenance .....	140
Troubleshooting .....	140
Repair and Rebuild .....	140
<b>Electrical Functions .....</b>	<b>141</b>
Theory of Operation .....	142
Battery Plugged In With Keypad .....	142
Battery Plugged In With Key Switch .....	144
Main ON/OFF Switch/Keypad ON .....	146
Travel, Low Speed .....	148
Travel, High Speed .....	150
Reverser .....	152
Lift .....	154
Lower .....	156
Maintenance .....	159
Wiring .....	159
Definitions .....	159
Shorts to Frame Test .....	160
Troubleshooting .....	163
Troubleshooting Flowchart .....	163
Main Harness Replacement .....	166
Operator Display and Programming .....	170
Special Modes .....	170
Service Display .....	171
Digital Inputs/Outputs from Transistor Controller .....	172
Transistor Controller System Mode .....	173
Changing Driver Accessible Parameters (P) .....	174
Changing Service Parameters .....	176
Parameter Description .....	179
Operating Parameter Programming .....	183

## Table of Contents

Display Part Numbers (Pn) .....	183
Error Codes (E) .....	183
Error Code History .....	183
Truck Fault Codes .....	184
Troubleshooting Chart Index .....	194
Travel (Tractor-first / Forks-first) System .....	194
Wiring System .....	194
Other Possible Troubleshooting Issues .....	194
Troubleshooting Charts .....	195
<b>Battery .....</b>	<b>199</b>
Theory of Operation .....	199
Maintenance .....	199
Inspection and Care .....	199
Exterior Cleaning .....	200
Charging .....	200
Storage .....	201
History Record .....	202
Troubleshooting .....	202
Repair and Rebuild .....	203
<b>Swing Out Battery Pack .....</b>	<b>205</b>
Theory of Operation .....	210
Maintenance .....	210
Electrical Testing .....	210
Required Equipment .....	210
Instructions .....	210
Troubleshooting .....	215
Repair and Rebuild .....	215
<b>Battery Connector .....</b>	<b>217</b>
Theory of Operation .....	217
Maintenance .....	217
Inspection .....	217
Troubleshooting .....	218
Repair and Rebuild .....	220
<b>Switches .....</b>	<b>221</b>
Theory of Operation .....	222
Maintenance .....	223
Troubleshooting .....	224
Repair and Rebuild .....	225
Main ON/OFF Switch .....	225
Arm Angle Switches .....	225
Key Switch (Optional) .....	227
Horn Switch .....	227
Converting Keypad to Key Switch .....	227
<b>Fuses .....</b>	<b>229</b>
Theory of Operation .....	229
Maintenance .....	229

## Table of Contents

Wiring Harness .....	230
Power Cables .....	231
Master Control Relay .....	232
Troubleshooting .....	233
Repair and Rebuild .....	233
<b>Contactor Panel .....</b>	<b>235</b>
Theory of Operation .....	237
Maintenance .....	237
Troubleshooting .....	237
Resistance Testing .....	237
Repair and Rebuild .....	238
<b>Transistor Controller .....</b>	<b>239</b>
Theory of Operation .....	239
Basics Of Circuit Operation .....	239
Interface .....	240
Control Features .....	241
Motor Circuit .....	241
Control Circuit .....	242
Definitions .....	243
Maintenance .....	244
Safety .....	244
Cleaning .....	244
Troubleshooting .....	245
Diagnostics and Troubleshooting .....	245
Fault Codes .....	245
Repair and Rebuild .....	247
<b>Electronic Tiller Arm Card (ETAC) .....</b>	<b>249</b>
Theory of Operation .....	250
Lift Cutout. ....	251
Maintenance .....	251
Troubleshooting .....	251
Repair and Rebuild .....	251
<b>Hydraulic System .....</b>	<b>253</b>
Theory of Operation .....	253
Lift .....	254
Lower .....	255
Relief Pressure .....	256
Maintenance .....	257
Changing Hydraulic System Fluid .....	257
Hydraulic Pump Pressure Relief Valve .....	259
Troubleshooting .....	259
Troubleshooting Chart Index .....	260
Troubleshooting Charts .....	260
Repair and Rebuild .....	263
Hydraulic Unit .....	265
Reservoir .....	266



## Table of Contents

Filter Screen and Inlet Tube .....	267
Lift Pump .....	268
<b>Lift Cylinder .....</b>	<b>269</b>
Theory of Operation .....	270
Maintenance .....	270
Inspection .....	270
Troubleshooting .....	270
Repair and Rebuild .....	271
<b>Mast .....</b>	<b>275</b>
Theory of Operation .....	275
Maintenance .....	275
Visual Inspection .....	275
Lift Chain Inspection .....	275
Lift Chain Lubrication .....	280
Lift Chain Adjustment .....	281
Mast Guides/Dampers Adjustment .....	281
Troubleshooting .....	282
Repair and Rebuild .....	283
<b>Forks .....</b>	<b>297</b>
Theory of Operation .....	298
Maintenance .....	298
Inspection .....	298
Troubleshooting .....	298
Repair and Rebuild .....	299
<b>Appendix .....</b>	<b>301</b>

## Standard Codes

## Standard Codes

- B-Code = Business area
- F-Code = Product family
- T-Code = Product type
- C-Code = Component function

### Worksheet standard

- W-Code = Working code
- R-Code = Reason code
- SO-Code = Assortment

### F-Code List

### T-Code List

No. Model  
7BWS10/13

### C-Code List

No	Function Group	C-Code
0	Chassis / Frame	0000
1	Motors	1000
2	Drive Gear / Transmission	2000
3	Brake / Wheel System	3000
4	Steering System	4000
5	Electrical System	5000
6	Hydraulic / Pneumatic System	6000
7	Operating Function-lifting Mast / Cylinders	7000
8	Peripheral / Installation Equipment	8000
9	Optionals / Attachments	9000
10	Tools	10000

---

# Warning Symbols

*Always follow the warnings given in this Service Manual and on the truck to avoid accidents from occurring.*

## 1. Warning Levels

### Warning levels

Warning text is given in four levels and provide information on the risks, describe the consequences, and instruct how to avoid accidents.

#### **DANGER**

*Warns that an accident will occur if the instructions are not followed.*

*The consequences are serious personal injury or possibly death, and/or extremely large material damage.*

#### **WARNING**

*Warns that an accident can occur if the instructions are not followed.*

*The consequences are serious personal injury or possibly death, and/or large material damage.*

#### **CAUTION**

*Warns that an accident can occur if the instructions are not followed.*

*The consequences are personal injury and/or material damage.*

#### **NOTE!**

*Marks the risk of a accident or breakdown if the instructions are not followed.*

## Prohibitory Symbols

Version no  
**001**

T-code

---

# Prohibitory Symbols



## NO SMOKING

*If smoking occurs in situations where a restriction against smoking is stated, a serious accident can occur.*



## OPEN FLAMES PROHIBITED

*If open flames are used in situations where open flames are prohibited, a serious accident can occur.*



## GENERAL PROHIBITION

*If the prohibition is ignored, a serious accident can occur.*

## 1. Ordinance Symbols



## SAFETY SHOES

*When the directive for safety shoes is given, safety shoes shall always be worn to avoid personal injury.*



## PROTECTIVE GLASSES

*When the directive for protective glasses is given, protective glasses shall always be worn to avoid personal injury.*

# Safety

## 1. General Safety

Do **NOT** operate or work on this truck unless trained, qualified, and authorized to do so and have read the Operator's Manual.



Know the truck controls and what they do.

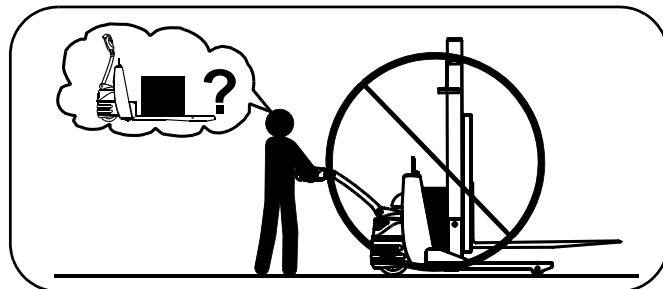

Do **NOT** operate truck if it needs repair or if it is in any way unsafe.



## Safety

Version no  
**001**

T-code

Operate truck only from the position of the operator.

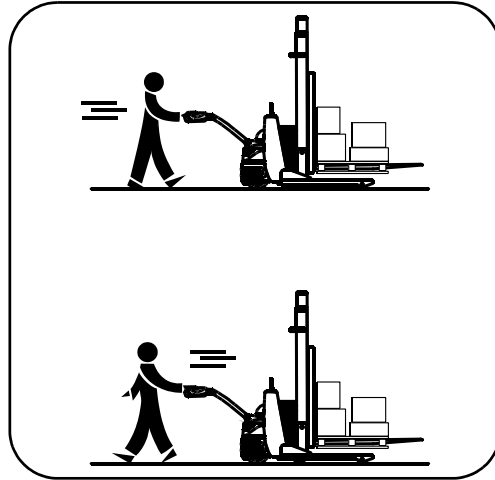

Before working on this truck always press the red **OFF (O)** key on the keypad and disconnect truck battery connector (unless this manual states otherwise).

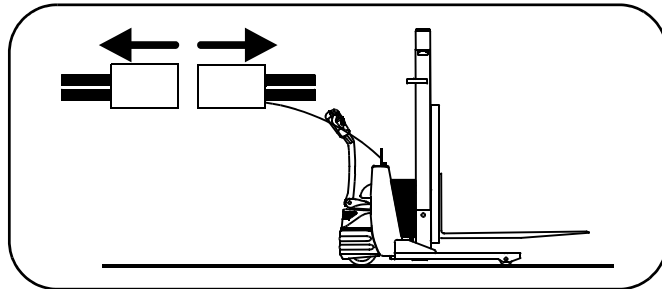

Do **NOT** wear watches, rings, or jewelry when working on this truck.

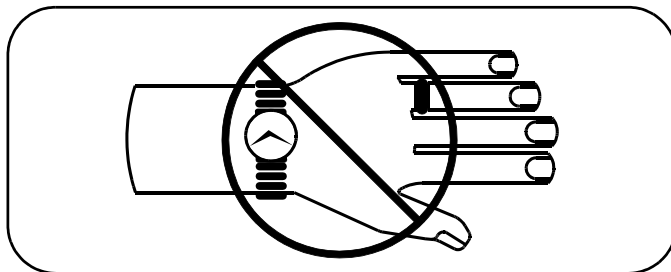

Follow the scheduled lubrication, maintenance, and inspection steps.

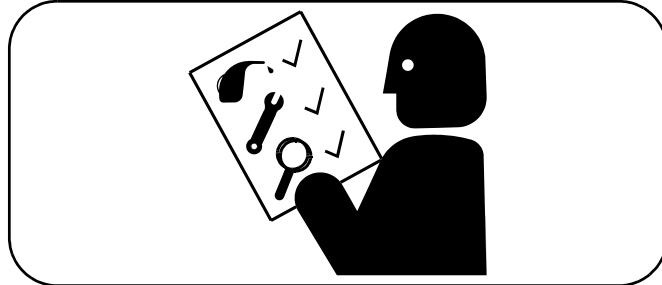

Follow exactly the safety and repair instructions in this manual. Do **NOT** take “shortcuts”.

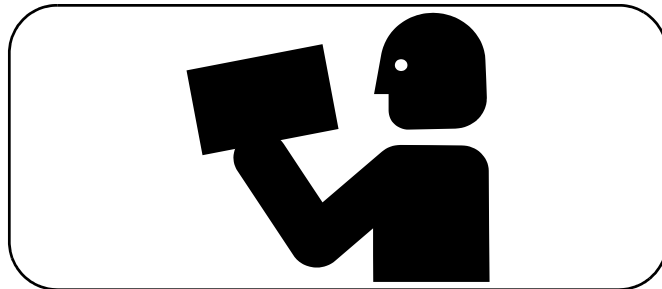

Do **NOT** Use an open flame near the truck.



Do **NOT** use gasoline or other flammable liquids for cleaning parts.

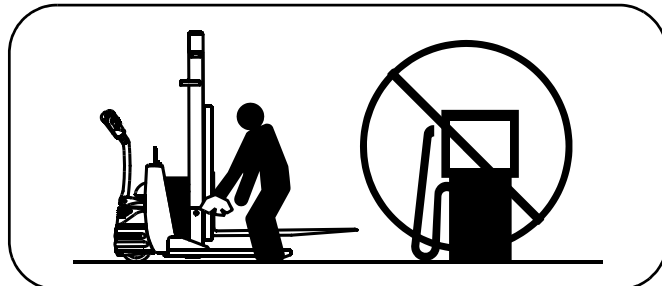

**Safety**Version no  
**001**

T-code

Clean up any hydraulic fluid, oil, or grease that has leaked or spilled on the floor.

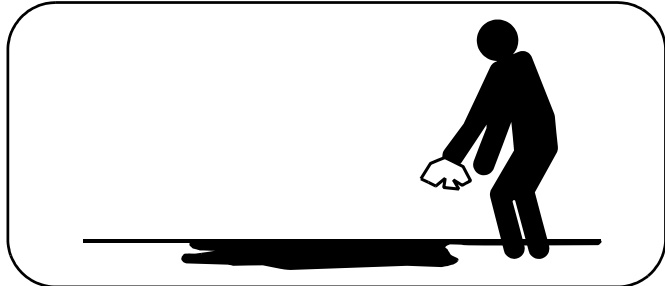

Always operate and park truck indoors.

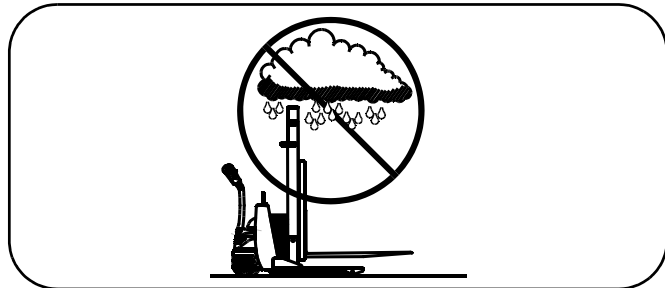

Do not park truck in a cold storage area overnight.

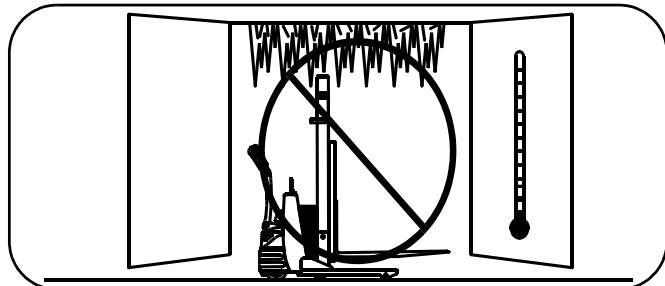

Do **NOT** wash truck with a hose.

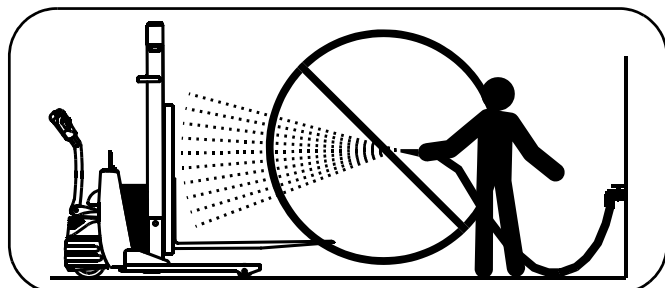



Do **NOT** add to or modify truck without written approval from **Toyota**

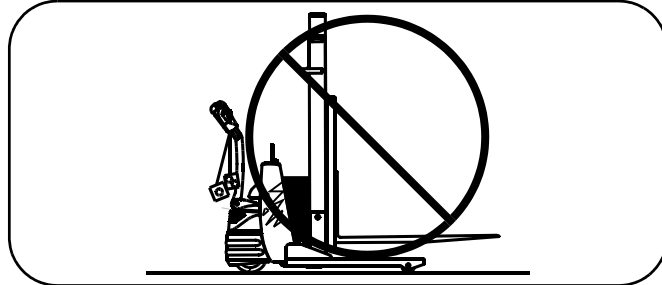

## Battery Safety

Version no  
**001**

T-code

# Battery Safety

**⚠ WARNING** As a battery is being charged, an explosive gas mixture forms within and around each cell. If the area is not properly ventilated, this explosive gas can remain in or around the battery for several hours after charging. Be sure there are no open flames or sparks in the charging area. An open flame or spark can ignite this gas, resulting in serious damage or injury.

**⚠ WARNING** Battery electrolyte is a solution of sulfuric acid and water. Battery acid causes burns. Should any electrolyte come in contact with clothing or skin, flush the area immediately with cold water. Should the solution get on your face or in the eyes, flush the area with cold water and receive medical attention immediately.

Read, understand and follow procedures, recommendations and specifications available by the battery and battery charger supplier.

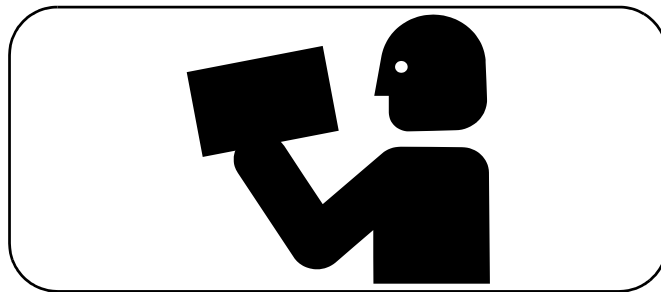

**Battery Safety**

Wear personal protective equipment to protect eyes, face, and skin when checking, handling, or filling batteries. This equipment includes goggles or face shield, rubber gloves (with or without arm shields) and a rubber apron.

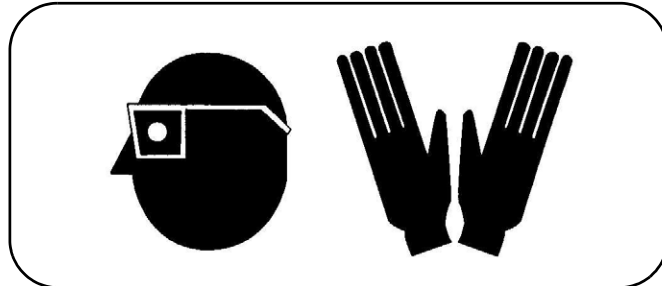

Make sure a shower and eyewash station are nearby in case there is an accident.

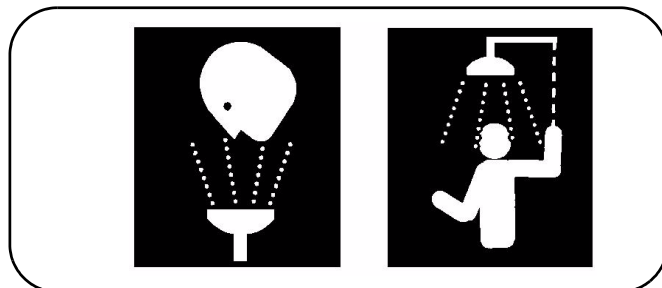

A battery gives off explosive gases. Never smoke, use an open flame, or use anything that gives off sparks near a battery.

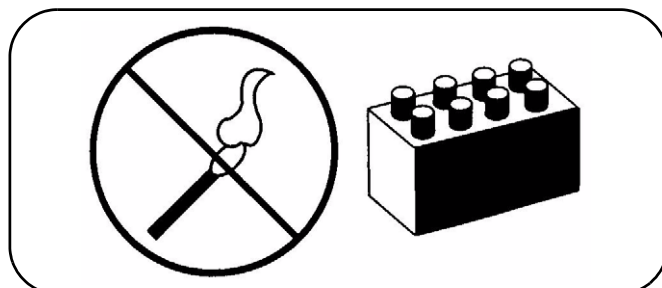

## Battery Safety

Version no

T-code

**001**

Keep the charger area well-ventilated to avoid hydrogen gas concentration.

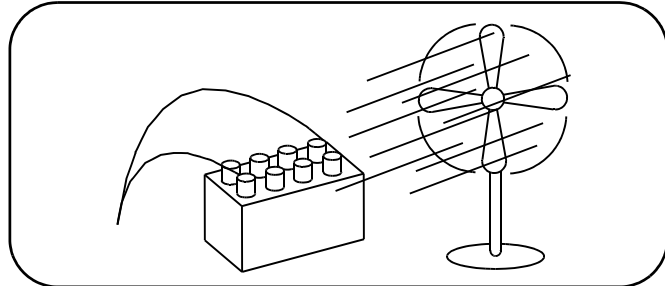

Press the red OFF (O) key on the keypad before disconnecting the battery from the truck at the battery connector. Do **NOT** break live circuits at the battery terminals. A spark often occurs at the point where a live circuit is broken.

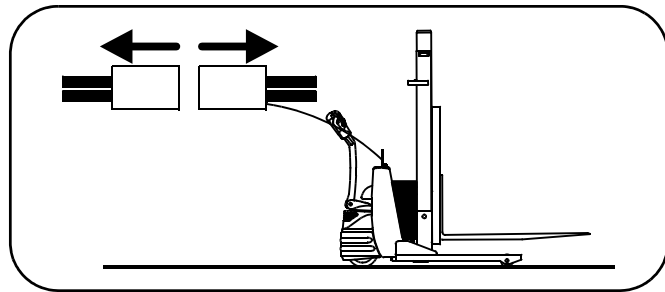

Do **NOT** lay tools or metal objects on top of battery. A short circuit or explosion could result.

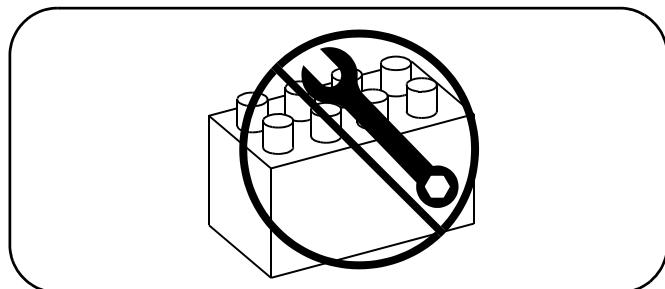

Keep batteries clean. Corrosion causes shorts and possibly sparks to the frame.

Keep plugs, terminals, cables, and receptacles in good condition to avoid shorts and sparks.

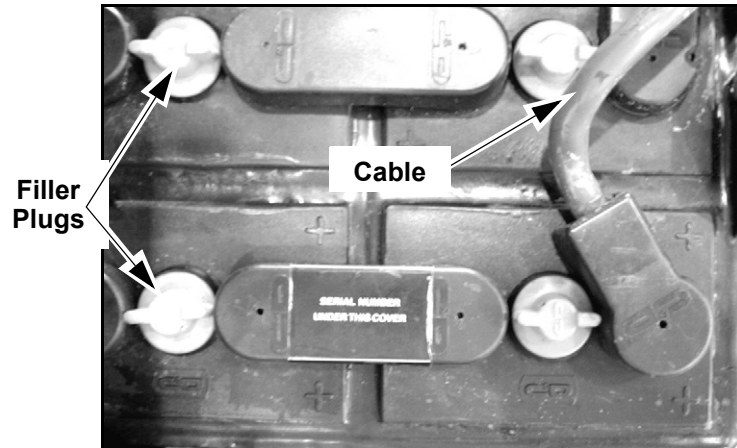

Keep filler plugs firmly in place at all times except when the electrolyte level is checked, when water is added to the cells or when the specific gravity is checked.

Make sure vent holes in filler plugs are open to allow gas to escape from the cells.

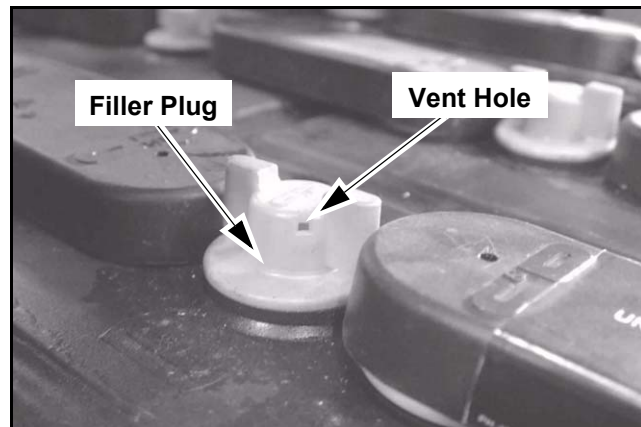

Do **NOT** allow cleaning solution, dirt, or any foreign matter to enter the cell.

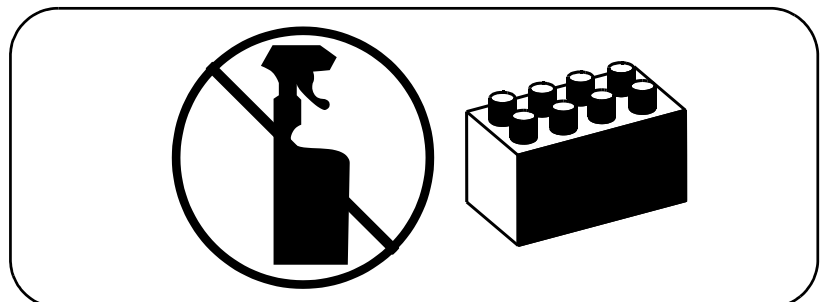



**Download the full PDF manual instantly.**

**Our customer service e-mail:**

**[aservicemanualpdf@yahoo.com](mailto:aservicemanualpdf@yahoo.com)**