



# SERVICE MANUAL

---

C3E100R

C3E130R

C3E150R



1,0-1,5 t A.C.	<h1>SERVICE MANUAL</h1>	ELECTRIC
INDEX page 2		036-0424-01

## INDEX

GENERAL INFORMATION .....	CHAPTER A
CHASSIS.....	CHAPTER 0000
MOTORS / ENGINES .....	CHAPTER 1000
TRANSMISSION / DRIVE GEAR.....	CHAPTER 2000
BRAKE .....	CHAPTER 3000
STEERING SYSTEM .....	CHAPTER 4000
ELECTRICAL SYSTEM .....	CHAPTER 5000
FYDRAULIC/PNEUMATIC SYSTEM .....	CHAPTER 6000
MAST GROUP .....	CHAPTER 7000
ATTACHEMENT .....	CHAPTER 8000
OPTIONS .....	CHAPTER 9000
MAINTENANCE TABLES.....	CHAPTER B
SAFETY INFORMATION .....	CHAPTER C

1,0-1,5 t A.C.	<h1>SERVICE MANUAL</h1>	ELECTRIC
CHAPTER 0000 page 2		036-0424-001

## CHASSIS

VEHICLE EXTERIOR VIEW.....	page 3
VEHICLE MODELS .....	page 4
FRAME NUMBER .....	page 4
HOW TO USE THIS MANUAL .....	page 5
DISASSEMBLY · INSPECTION · REASSEMBLY .....	page 5
TERMINOLOGY .....	page 6
ABBREVIATIONS.....	page 6
SI UNITS .....	page 7
OPERATING TIPS.....	page 8
GENERAL INSTRUCTIONS .....	page 8
JACK-UP POINT .....	page 9
LIFTING THE VEHICLE .....	page 10
MEMBER WEIGHTS .....	page 11
TOWING THE VEHICLE .....	page 11
ELECTRICAL PARTS INSPECTION.....	page 12
TIGHTENING TORQUE TABLE .....	page 13
COMPONENTS (Body & Frame) .....	page 14
BATTERY COVER.....	page 18
REMOVAL · INSTALLATION .....	page 18
COUNTERWEIGHT .....	page 19
REMOVAL · INSTALLATION .....	page 19
OPERATOR'S SEAT .....	page 20
REMOVAL · INSTALLATION .....	page 20
FUSES.....	page 21

## VEHICLE EXTERIOR VIEW

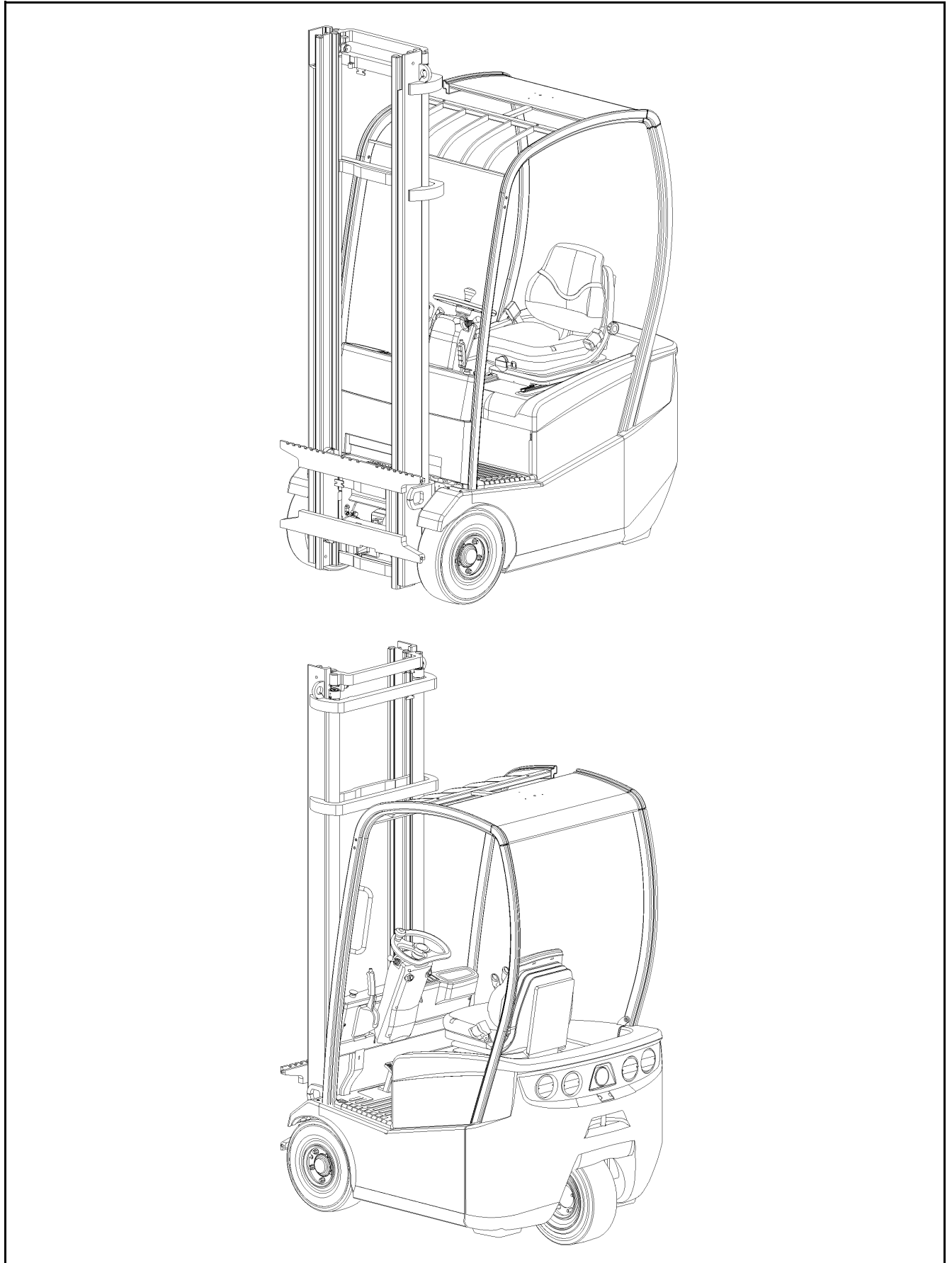

**VEHICLE MODELS**

Vehicle model code	Load Capacity	Control method	Voltage (V)
100	1.0 ton	AC microcomputer controller	24
130	1.25 ton	↑	↑
150	1.5 ton	↑	↑

**FRAME NUMBER**

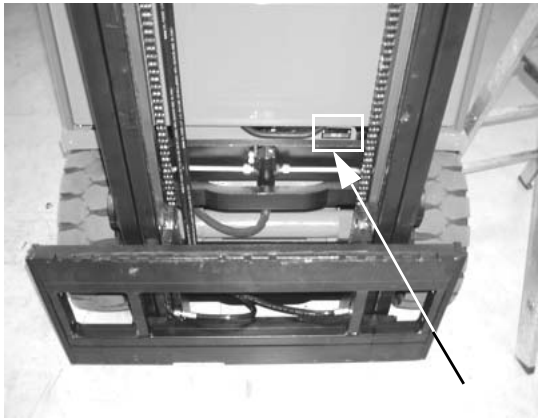
Vehicle model code	S/N Format	Serial number position
100	CE000000	
130	CE000000	
150	CE000000	

## HOW TO USE THIS MANUAL

### EXPLANATION METHOD

1. Operating procedure
2. Operating procedures are described using either pattern A or pattern B.
3. Pattern A: Each step of the operation is explained with its own illustration.
4. Pattern B: The entire operation is indicated by step numbers in one illustration, followed by cautions, notes, and point operations.

### Example of pattern B

## DISASSEMBLY · INSPECTION · REASSEMBLY

T=N·m

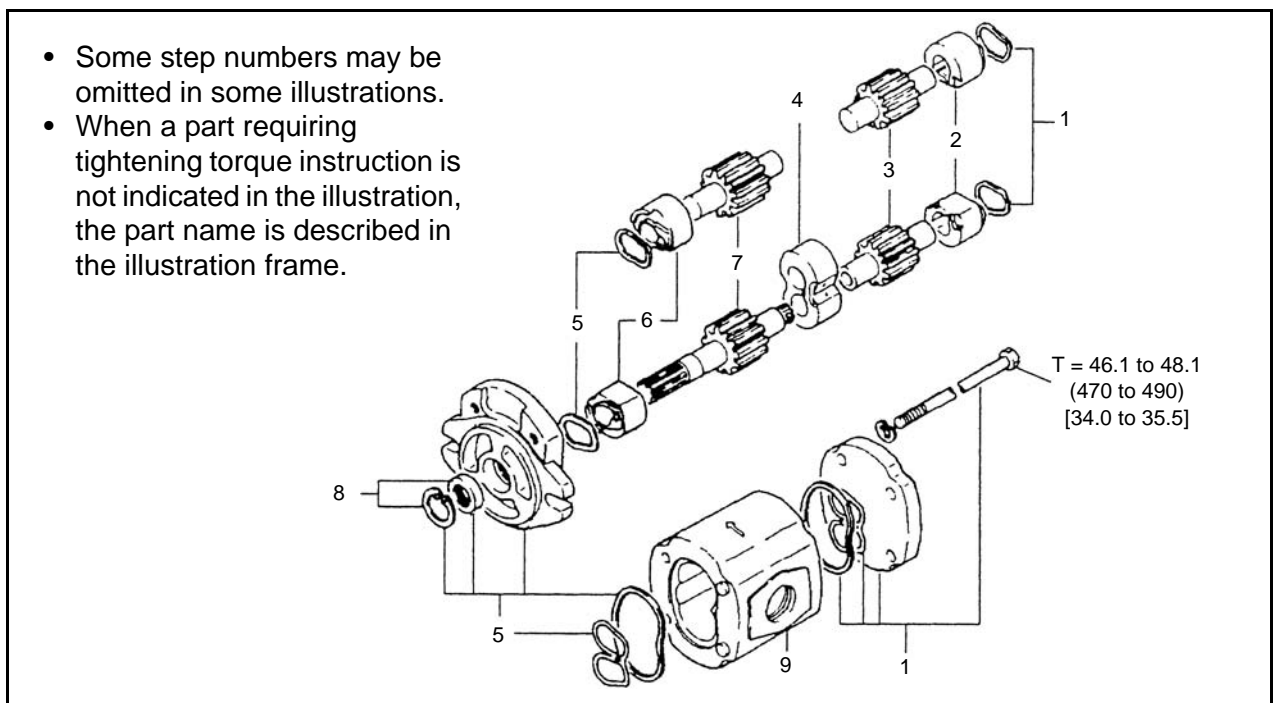

### Disassembly Procedure

- 1 Remove the cover. **[POINT 1]**
- 2 Remove the bushing. **[POINT 2]**
- 3 Remove the gear.

← Operation to be explained

### Point Operations

#### **[POINT 1]**

Disassembly:

Make match marks before removing the pump cover

← Explanation of operation point with illustration

#### **[POINT 2]**

Inspection:

Measure the bushing inside diameter

**Limit 19.12 mm.**

1,0-1,5 t A.C.	<b>SERVICE MANUAL</b>	ELECTRIC
CHAPTER 0000 page 6		036-0424-01

1. Matters omitted from this manual

- (1) This manual omits descriptions of the following jobs, but perform them in actual operation:
- (a) Cleaning and washing of removed parts as required
  - (b) Visual inspection (partially described)

## TERMINOLOGY

### Caution:

Important matters, negligence of which may cause accidents. Be sure to observe them.

### Note:

Important items, negligence of which may cause accidents, or matters in operating procedure which require special attention.

**Standard:** Value showing the allowable range in inspection or adjustment

**Limit:** The maximum or minimum value allowed in inspection or adjustment.

## ABBREVIATIONS

Abbreviation	Meaning	Abbreviation	Meaning
ATT	Attachment	SAE	Society of Automotive Engineers (USA)
EHPS	Electronically controlled fully hydraulic power steering	RH	Right hand
FHPS	Fully hydraulic power steering	SST	Special service tool
LH	Left hand	STD	Standard
L/	Less	T=	Tightening torque
OPT	Option	○ ○ T	Number of teeth (○ ○ T)
O/S	Oversize	U/S	Undersize
PS	Power steering	W/	With

ELECTRIC	<b>SERVICE MANUAL</b>	1,0-1,5 t A.C.
036-0424-01		CHAPTER 0000 page 7

## SI UNITS

### Meaning of SI

This manual uses SI units. SI represents the International System of Units, which was established to unify the various systems of units used in the past for smoother international technical communication.

### New Units Adopted in SI

Item	New unit	Conventional unit	Conversion rate* <sup>1</sup> (1 [conventional unit] = X [SI unit])
Force* <sup>2</sup>	N (newton)	kgf	1 kgf = 9.80665 N
Torque* <sup>2</sup> (Moment)	N·m	kgf·cm	1 kgf·cm = 9.80665 N·m
Pressure* <sup>2</sup>	Bar	kgf/cm <sup>2</sup>	1 Bar = 1 kgf / cm <sup>2</sup>
Pressure* <sup>2</sup>	Pa (pascal)	kgf/cm <sup>2</sup>	1 kgf/cm <sup>2</sup> = 98.0665 kPa = 0.0980665 MPa
↑	↑	mmHg	1 mmHg = 0.133322 kPa
Revolving	rpm	rpm	1 rpm = 1 r/min
Spring con-	N/mm	kgf/mm	1 kgf/mm = 9.80665 N/mm
Volume	l	cc	1 cc = 1 mℓ
Power	W	PS system	1 PS = 0.735499 kW
Heat quantity	W·h	cal	1 kcal = 1.16279 W·h
Specific fuel	g/W·h	g/PS·h	1 g/PS·h = 1.3596 g/kW·h

### <Reference>

\* 1: X represents the value in SI units as converted from 1 [in conventional units], which can be used as the rate for conversion between conventional and SI units.

\* 2: In the past, kilogram [kg] representing mass was often used in place of weight kilogram [kgf], which should be used as the unit of force.

### Conversion between Conventional and SI Units

#### Equation for conversion

Value in SI unit = Conversion rate × Value in conventional unit	Conversion rate: Figure corresponding to X in the conversion rate column in the table above
Value in conventional unit = Value in SI unit ÷ Conversion rate	

**When converting, change the unit of the value in conventional or SI units to the one in the conversion rate column in the table above before calculation. For example, when converting 100 W to the value in conventional unit PS, first change it to 0.1 kW and divide by the conversion rate 0.735499.**



1,0-1,5 t A.C.	<h1>SERVICE MANUAL</h1>	ELECTRIC
CHAPTER 0000 page 8		036-0424-01

## OPERATING TIPS

### GENERAL INSTRUCTIONS

1. Safe operation
  - (1) After jacking up, always support with wooden blocks or rigid stands.
  - (2) When hoisting the vehicle or its heavy component, use wire rope(s) with a sufficient reserve in load capacity.
  - (3) Always disconnect the battery plug before the inspection or servicing of electrical parts.
2. Skillful operation
  - (1) Prepare the tools, necessary measuring instruments (circuit tester, megohmmeter, oil pressure gauge, etc.) and SSTs before starting operation.
  - (2) Check the cable color and wiring state before disconnecting any wiring.
  - (3) When overhauling functional parts, complicated sections or related mechanisms, arrange the parts neatly to prevent confusion.
  - (4) When disassembling and inspecting a precision part such as the control valve, use clean tools and operate in a clean location.
  - (5) Follow the specified procedures for disassembly, inspection and reassembly.
  - (6) Always replace gaskets, packing, O-rings, self-locking nuts and cotter pins with new ones each time they are disassembled.
  - (7) Use genuine Toyota parts for replacement.
  - (8) Use specified bolts and nuts and observe the specified tightening torque when reassembling. (Tighten to the medium value of the specified tightening torque range.) If no tightening torque is specified, use the value given in the "standard tightening torque table".
3. Protection of functional parts (battery operated vehicles)
  - (1) Before connecting the battery plug after vehicle inspection or maintenance, thoroughly check each connector for any connection failure or imperfect connection.  
Failure or imperfect connection of connectors related to controllers, especially, may damage elements inside the controllers.
4. Defect status check
 

Do not start disassembly and/or replacement immediately, but first check that disassembly and/or replacement is necessary for the defect.
5. Waste fluid disposal
 

Always use a proper container when draining waste fluid from the vehicle.  
Careless discharge of oil, fuel, coolant, oil filter, battery or other harmful substance may adversely affect human health and the environment. Always collect and sort well, and ask specialized companies for appropriate disposal.

## JACK-UP POINT

Always observe the following instructions when jacking up the vehicle:

- When the fork is loaded, unload it and park the vehicle on a flat surface. Be sure to avoid an inclined or rough surface.
- Use a jack with ample capacity and jack up the vehicle at the specified jack-up point. Jacking up at any other point is dangerous.
- Always support the load of jacked-up vehicle with wooden blocks at specified points. Supporting the vehicle with the jack only is very dangerous.
- Never, under any circumstances, put any part of the body (including hands and feet) under the jacked-up vehicle.

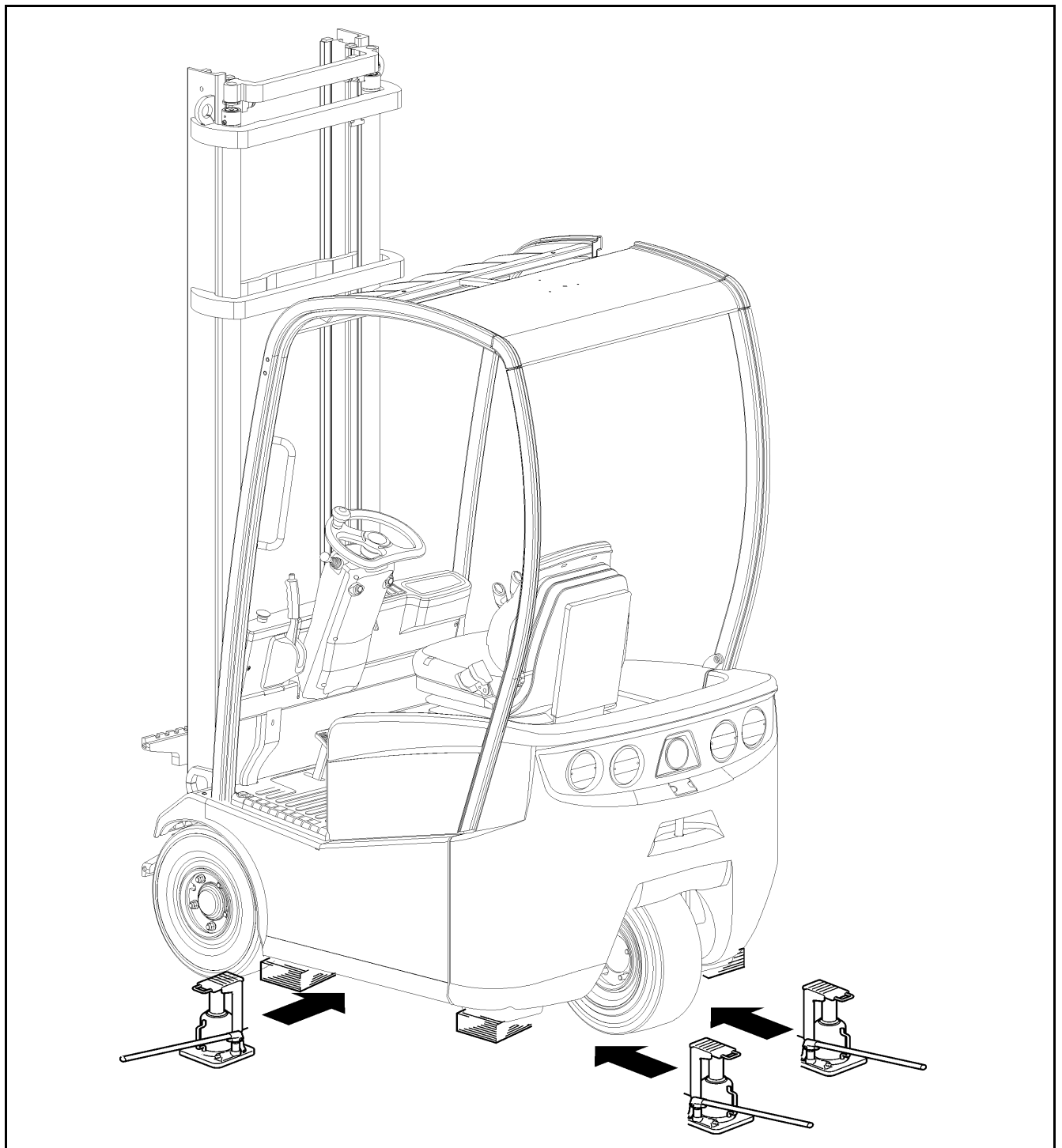

**LIFTING THE VEHICLE**

When hoisting the vehicle, always observe the specified hoist attachment section and method. Never hoist by any other attachment section as it is very dangerous.

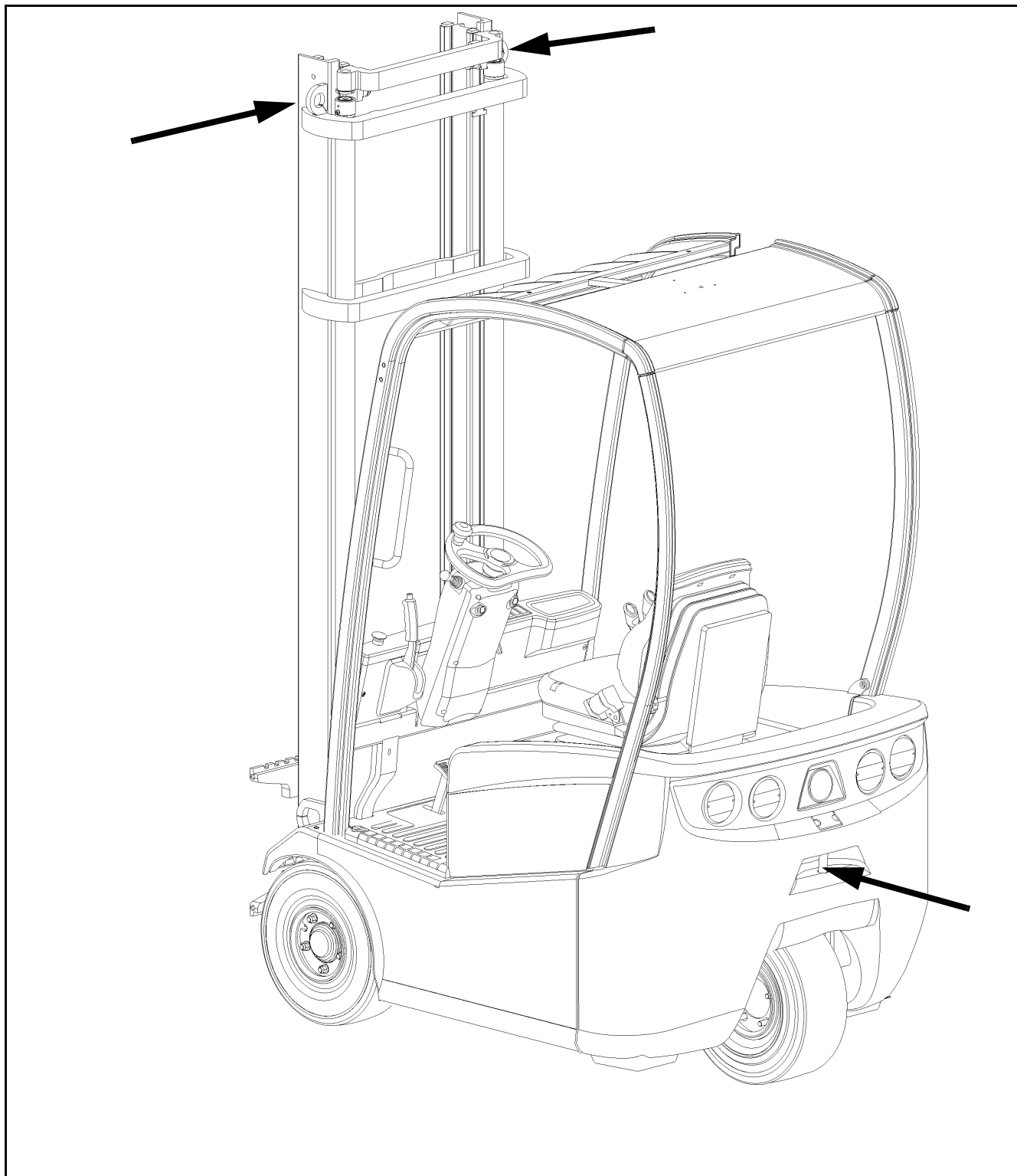

## MEMBER WEIGHTS

Unit: kg

Member	Vehicle model code	Weight
BATTERY	100	min. 381 - max. 420
	130	min. 524 - max. 590
	150	min. 600 - max. 690
Drive motor	All Models	Approx.34
Pump motor (Hydraulic pump + electric motor)	All Models	Approx.40
Rear axle L/Drive motor and wheel	All Models	Approx.53
Counterweight	All models	900
Mast W/ lift bracket (W/ lift cylinder, L/ fork, Lifting height 4000 mm, V mast	All Models	Approx 450
Vehicle weight (w/battery)	100	Approx.2550
	130	Approx.2820
	150	Approx.2930

## TOWING THE VEHICLE

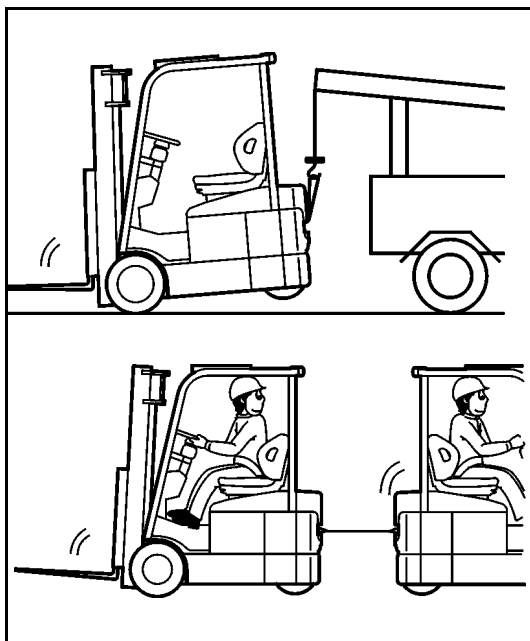

**Note the cautions below when towing the vehicle.**

1. Lift the rear wheels for towing
2. The traveling speed when towing must not exceed the maximum traveling speed of the forklift.
3. Before starting towing, always set the key switch to OFF and the direction switch to the neutral position.
4. Before towing, either remove the fork or take action to prevent the fork from coming into contact with the ground due to bouncing.

## ELECTRICAL PARTS INSPECTION

1. Always disconnect the battery plug before inspecting or servicing electrical parts.
2. Pay sufficient attention when handling electronic parts.

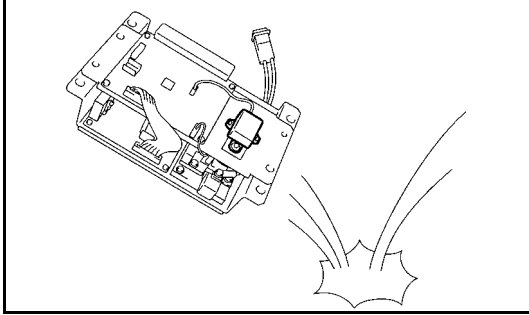

- (1) Never subject electronic parts, such as computers and relays, to impact.
  - (2) Never expose electronic parts to high temperature or moisture.
  - (3) Do not touch connector terminals, as they may be deformed or damaged due to static electricity.
3. Use a circuit tester that matches the object and purpose of measurement.

Analog type: This type is convenient for observing movement during operation and the operating condition. Measured value is only a reference

Digital type: A fairly accurate reading is possible. However, it is difficult to observe operation or movement.

- (1) Difference between results of measurement with analog and digital types
  - \* The results of measurements using the analog type and the digital type may be different.
  - Differences between the polarities of the analog type and the digital type are described below.

### 1) Analog circuit tester

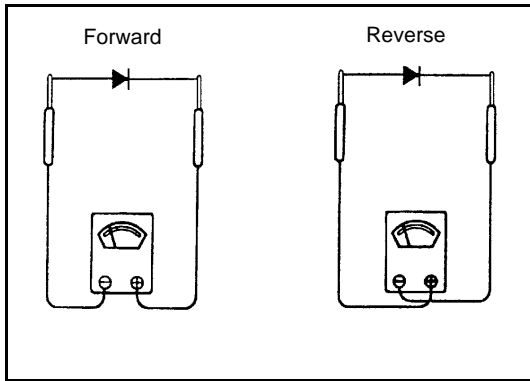

Example of measurement result  
Tester range: kΩ range

	Analog type
Forward	Continuity
	11 kΩ
Reverse	No continuity
	∞

### 2) Digital circuit tester

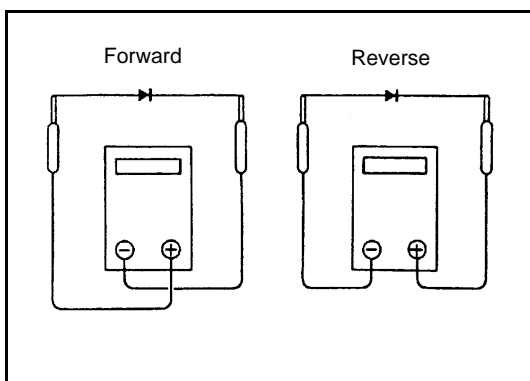

Example of measurement result  
Tester range: 2 MΩ range

	Digital type
Forward	No continuity
	1
Reverse	Continuity
	2 MΩ

ELECTRIC	<b>SERVICE MANUAL</b>	1,0-1,5 t A.C.
036-0424-01		CHAPTER 0000 page 13

## TIGHTENING TORQUE TABLE

The tables here below are valid for screws and bolts without superficial covering, preventively lubricated with oil.

### SCREWS WITH "ISO" METRIC COARSE THREAD

Nominal diameter mm	PRELOADING V (IN)				TORQUE Max (N.m)			
	6 D	8 G	10 K	12 K	6 D	8 G	10 K	12 K
	6,6	8,8	10,9	12,9	6,6	8,8	10,9	12,9
M 4 x 0,7	21781	3865	5435	6524	1,7	3	4,2	5,1
M 5 x 0,8	3502	6229	8780	10497	3,2	5,8	8,2	9,9
M 6 x 1	4974	8849	12459	14911	5,7	10	14,3	17,1
M 7 x 1	7142	12753	17854	21386	9,2	16,6	23	27,8
M 8 x 1,25	9025	16088	22661	27174	13,6	24,3	34	41,1
M 9 x 1,25	11870	21190	29921	35610	20,1	36	50,8	60,5
M 10 x 1,5	14519	25506	35905	42968	27,8	49	69	82
M 12 x 1,75	20797	37082	52189	62588	46,5	83	117	140
M 14 x 2	28351	50620	71123	85347	74	132	186	223
M 16 x 2	38750	68866	97119	116739	113	200	283	339
M 18 x 2,5	47480	84366	118701	142245	157	279	392	471
M 20 x 2,5	60430	107910	151565	181485	218	388	545	653
M 22 x 2,5	74850	133416	187371	224649	294	520	731	883
M 24 x 3	87309	155979	218763	261927	383	687	961	1148
M 27 x 3	112815	202086	283509	340407	549	991	1393	1668
M 30 x 3	138321	247212	347274	415944	755	1354	1893	2276

### SCREWS WITH "ISO" FINE THREAD

Nominal diameter mm	PRELOADING V (IN)				TORQUE Max (N.m)			
	6 D	8 G	10 K	12 K	6 D	8 G	10 K	12 K
	6,6	8,8	10,9	12,9	6,6	8,8	10,9	12,9
M 8 x 1	9761	17168	24231	29038	14,5	25,5	36,2	43
M 10 x 1,25	15107	26879	37867	45420	28,4	51	72	85
M 12 x 1,25	23740	40613	56898	68474	52	89	126	151
M 12 x 1,5	21778	38848	54642	65531	49	87	123	147
M 14 x 1,5	30902	54936	77303	92705	78	140	196	235
M 16 x 1,5	41202	73575	103005	123606	118	211	294	353
M 18 x 1,5	53268	95157	133416	159903	171	304	422	510
M 20 x 1,5	67689	118701	168242	202086	239	422	598	716
M 22 x 1,5	82404	147150	206010	247212	314	564	790	952
M 24 x 2	94667	168732	237402	284490	402	721	1010	1216
M 27 x 2	122625	218763	307053	367875	589	1050	1472	1766
M 30 x 2	154017	272718	384552	461070	814	1442	2040	2453

## COMPONENTS

### Body & Frame

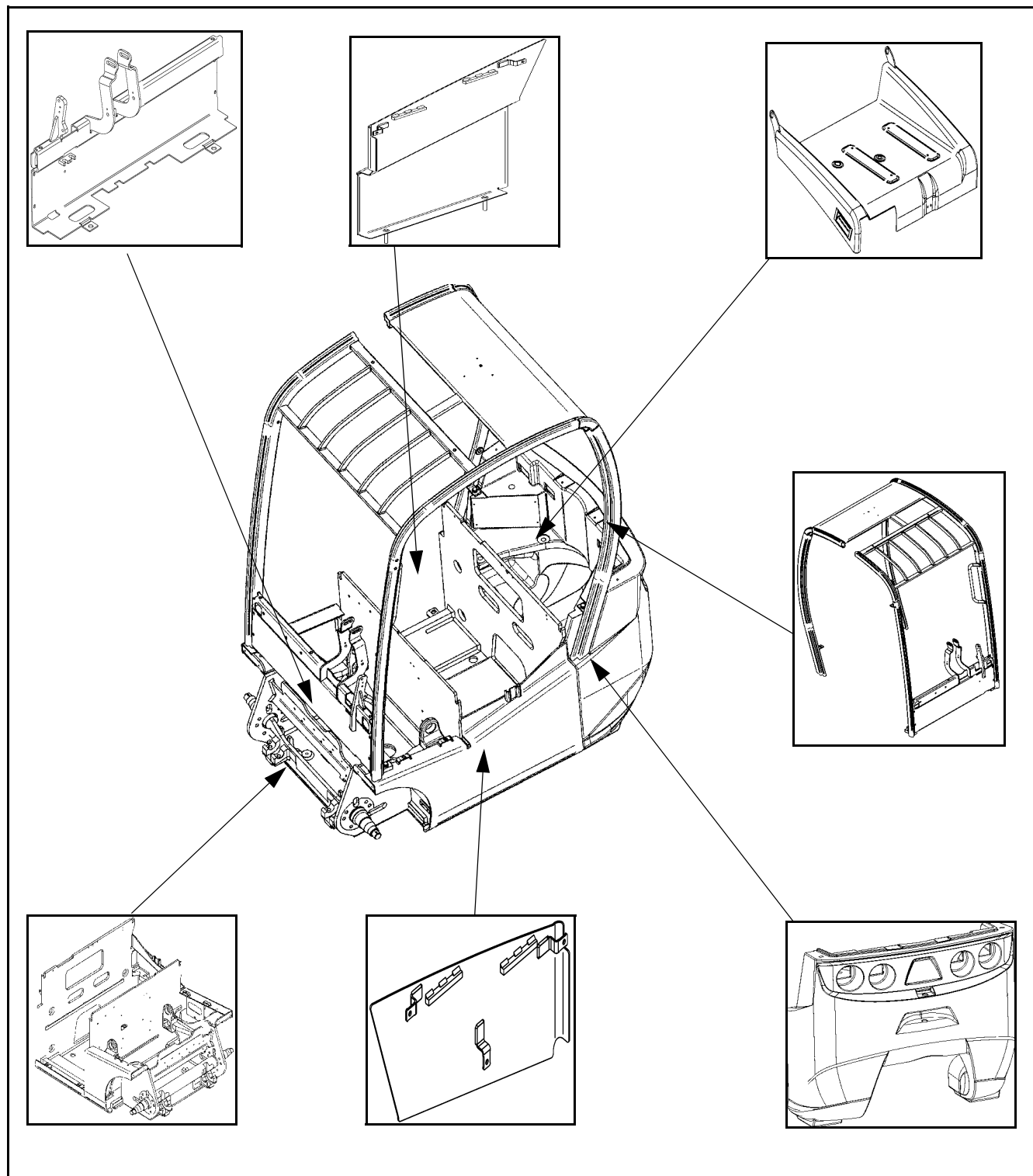

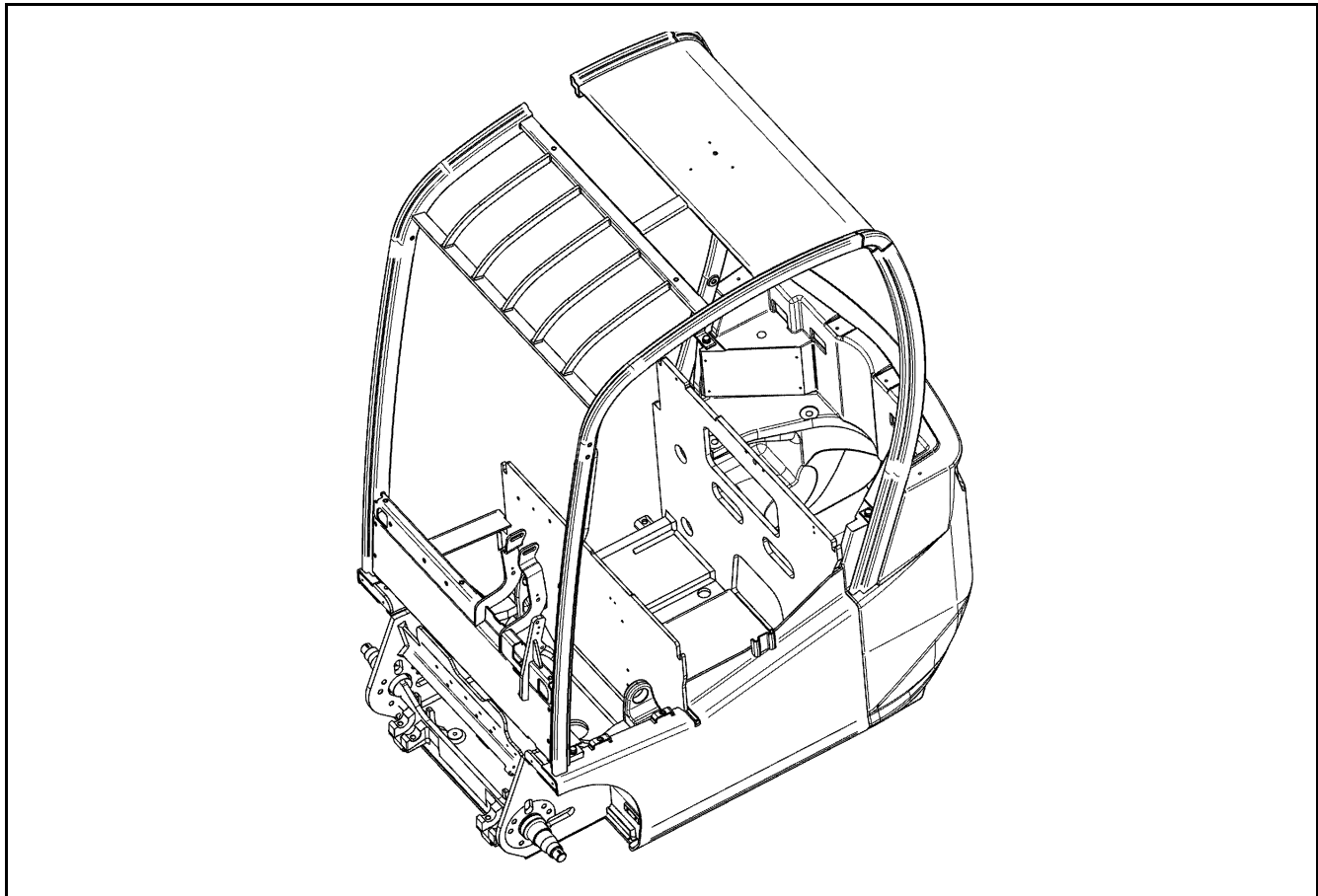
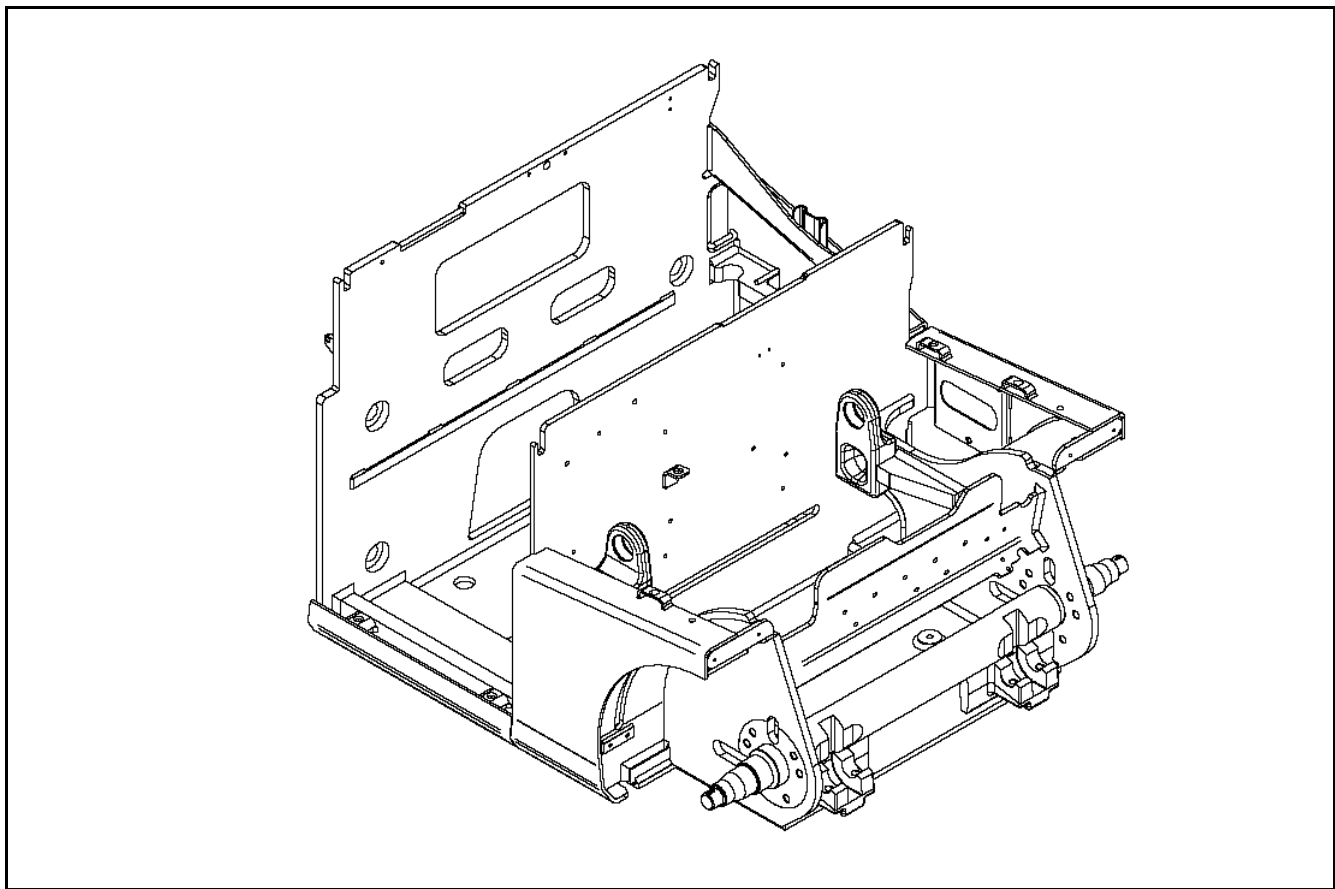



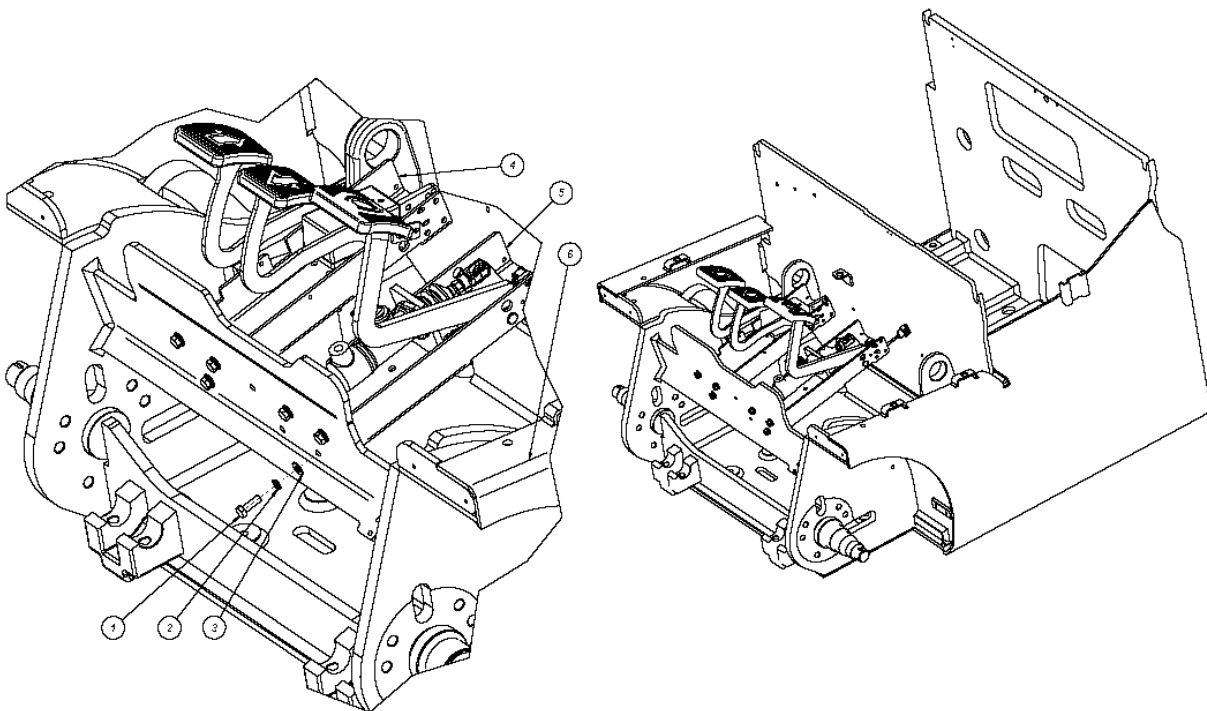
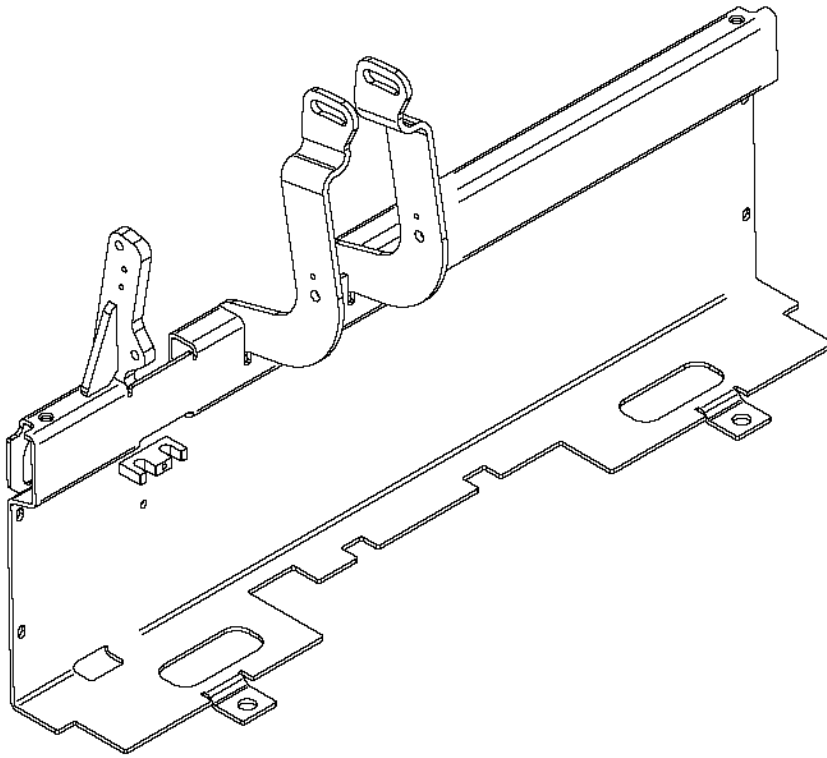

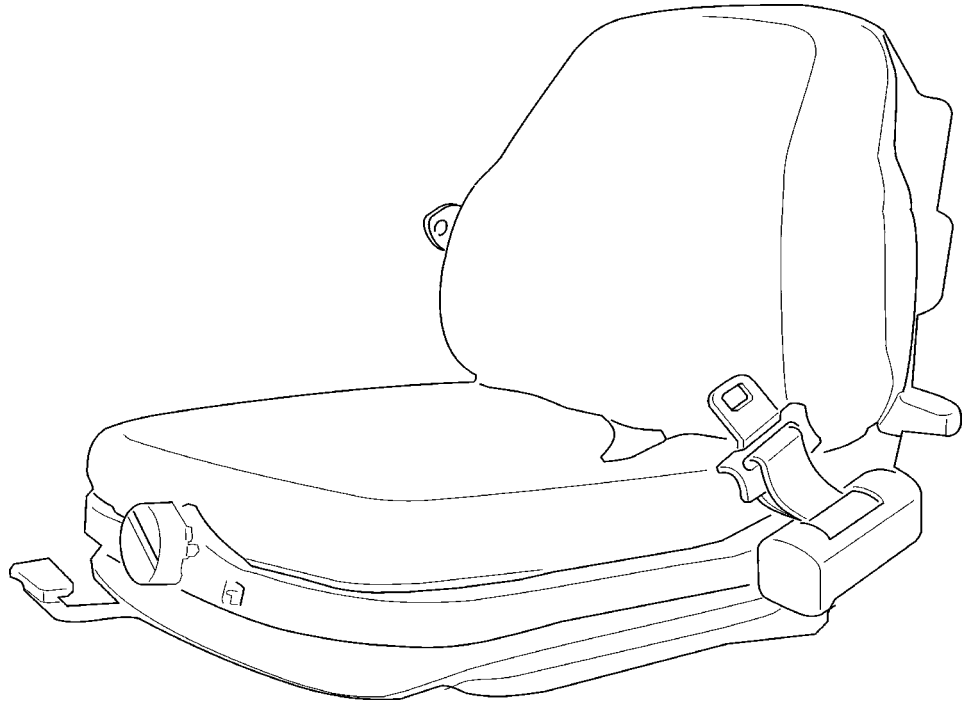

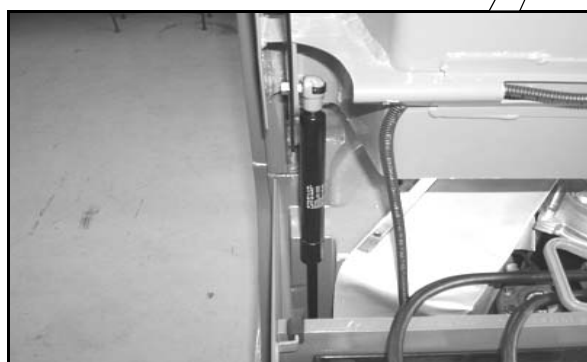
**BATTERY COVER  
REMOVAL • INSTALLATION****Removal Procedure**

- 1 Disconnect the battery plug.
- 2 Open the battery cover.
- 3 Use string to tie the battery cover W/seat to the head guard rear pillar.
- 4 Disconnect the wiring of the seat switch.
- 5 Disconnect the battery cover gas spring (on the frame side).
- 6 Close the battery cover.
- 7 Remove the battery cover hinge set bolt.
- 8 Remove the battery cover W/ seat.

**Installation Procedure**

The installation procedure is the reverse of the removal procedure.

## COUNTERWEIGHT REMOVAL • INSTALLATION



### Removal Procedure

- 1 Disconnect the battery plug.
- 2 Remove the rear cover and battery cover.
- 3 Remove the battery.
- 4 Disconnect the controller cables and the contactor group.
- 5 Disconnect the hydraulic motor hoses.
- 6 Set the hoisting attachment and remove the counterweight set bolt.
- 7 Remove the counterweight.

### Installation Procedure

The installation procedure is the reverse of the removal procedure.

**Tightening torque of the 4 bolts of the counterweight = 425 Nm.**

**(Note: Tight the bolts with the sequence V<sub>1</sub>, V<sub>2</sub>, V<sub>3</sub>, V<sub>4</sub>).**

**Tightening torque of the 2 bolts of the OHG = 83 Nm.**

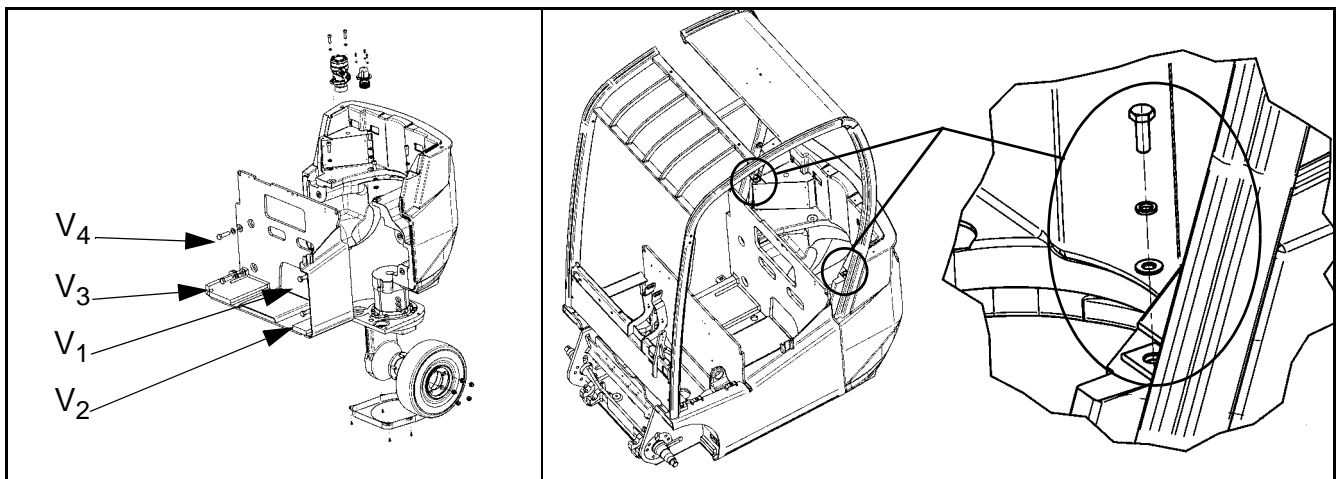

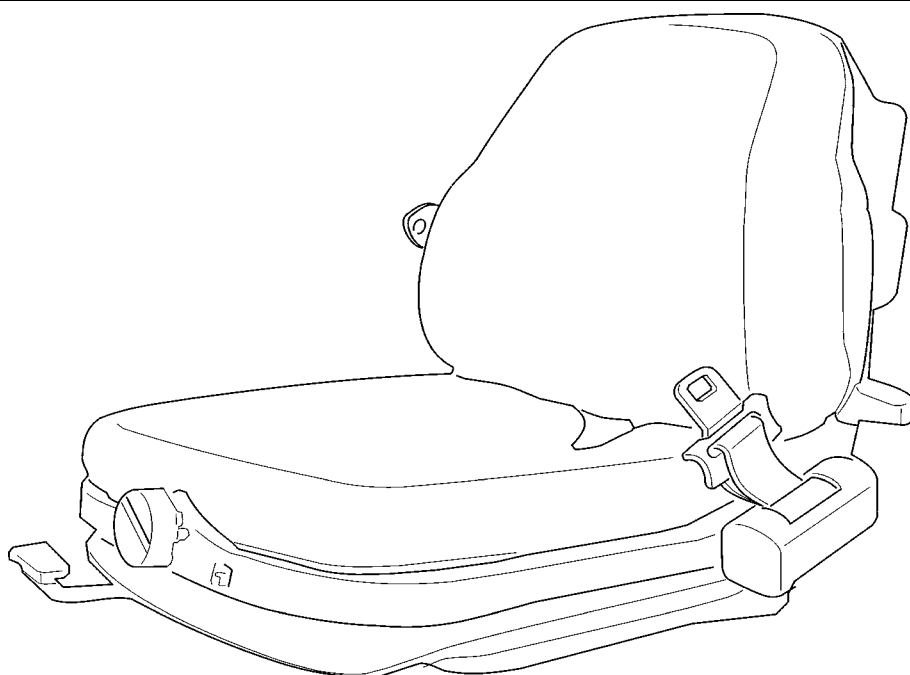
**OPERATOR'S SEAT  
REMOVAL • INSTALLATION****Removal Procedure**

- 1 Open the battery cover.
- 2 Disconnect the wiring of the seat switch.
- 3 Remove the operator's seat set nuts. (Be careful not to drop the operator's seat).
- 4 Remove the operator's seat.

**Installation Procedure**

The installation procedure is the reverse of the removal procedure.



**Download the full PDF manual instantly.**

**Our customer service e-mail:**

**[aservicemanualpdf@yahoo.com](mailto:aservicemanualpdf@yahoo.com)**