



Service Manual

7BPUE15

Serial Numbers
80,001 and up



INDUSTRIAL EQUIPMENT

Service Manual

High Level Orderpicker

Model 7BPUE15
Serial No. 80,001 and up



Table of Contents

How to Use This Manual	1-1
Map of the Manual	1-2
Manual Design	1-4
Page Revision Page	1-5
START Page	1-7
Safety	2-1
Definitions	2-2
General Safety	2-3
Battery Safety	2-6
Static Safety	2-9
Jacking Safety	2-11
Tie-Down for Transport	2-13
Towing a Disabled Unit	2-14
Welding Safety	2-15
Systems Overview	3-1
Vehicle Specification	3-2
General System Data	3-5
Installation Instructions	3-7
Wire Guidance	3-8
Cold Storage	3-9
UL Label "EE"	3-11
Special Tools	3-12
Planned Maintenance	4-1
Maintenance Guidelines	4-2
Interval 1	4-3
Interval 2	4-4
Interval 3	4-8
Troubleshooting	5-1
How to Use This Chapter	5-2
Electrical Troubleshooting Guidelines	5-3
Shorts to Frame Test	5-4
Troubleshooting Wiring Problems	5-8
Switches (General)	5-10
Electric Motor Tests	5-11
Battery Discharge Indicator (BDI)	5-13
Contactors	5-15
Fuses	5-15
Hydraulic Troubleshooting Guidelines	5-16
Definitions	5-17
Electrical Connector Locator Chart	5-18
Programmable Maintenance Tool	5-20
Drive Unit Troubleshooting Guide	5-25
Troubleshooting Flowcharts	5-27
Symptom Tables: Hydraulic Functions	5-31
Symptom Tables: Travel Functions	5-33
Symptom Tables: Electrical Symptoms	5-34
Codes and Tests	6-1
Operator Display Messages	6-2
Maintenance Mode	6-4

Traction Power Amplifier Fault Codes	6-6
Operator Display Fault Codes	6-15
Component Procedures	7-1
List of Component Procedures	7-2
Component Locator Photos	7-5
Covers and Finish	7-11
Tractor Covers	7-11
Operator Console Cover	7-12
Mast Guard	7-13
Decals	7-14
Steering and Controls	7-15
Operator Display	7-16
Control Handle	7-17
Drive and Brake	7-23
Drive Unit	7-24
Drive Wheel	7-25
Brake	7-27
Electrical Components	7-31
Battery Procedures	7-32
Motors (General)	7-35
Drive Motor	7-39
Lift Motor	7-41
Steer Motor	7-42
Traction Power Amplifier	7-45
Contactors	7-46
Contactor Tip Replacement	7-48
Fuses	7-50
Circuit Cards (General)	7-52
Switches (General)	7-53
Warning Light	7-55
Hydraulic Components	7-57
Hydraulic Manifold	7-58
Hydraulic Reservoir	7-59
Hydraulic Fluid	7-60
Solenoid Valves	7-61
Lift Pump and Motor	7-62
Lift Pressure Relief Valve Adjustment	7-63
Bleeding the Hydraulic System	7-64
Side Cylinder	7-65
Center Cylinder	7-69
Flow Control Valve	7-71
Mast Section	7-73
Three-Stage Carriage	7-74
Inner Mast	7-78
Outer Mast	7-81
Two-Stage Carriage	7-82
Two-Stage Mast	7-84
Mast Bearings	7-85
Mast Disassembly and Shimming	7-87
Lift Chains, Three-Stage	7-91
Lift Chains, Two-Stage	7-93
Forks	7-94

Pallet Clamp	7-95
Load Wheels	7-96
Skid Pads	7-97
Wire Guidance	8-1
System Overview	82
Install Kit Components	83
Set-Up Procedure	89
Codes and Tests	8-12
Tests	8-35
General Troubleshooting	8-37
Troubleshooting in FlashWare	8-38
Theory of Operation	8-40
Theory of Operation	9-1
Battery Plugged In	9-4
Key Switch (S1) On	9-10
Closing Deadman Switches	9-16
Travel	9-22
Steering	9-28
Lift/Lower	9-34
Primary Memory	9-50
Pinout Matrix	9-51
Firmware Configuration	10-1
FlashWare Program	10-2
Appendix	A-1
Lubrication Specification Chart	A-2
Torque Chart _ Standard (Ferrous)	A-3
Torque Chart _ Standard (Brass)	A-4
Torque Chart _ Metric	A-5
Decimal Equivalent Chart	A-6
Standard/Metric Conversions	A-8
Electrical Schematics	A-11
Hydraulic Schematic	A-18

Manual Design

Manual Design

This Service Manual is designed with the following objectives in mind:

- Provide technical coverage for expected levels of user expertise.
- Anticipate your needs and reduce your decisions regarding maintenance.
- Reduce page flipping through a "one-stop shopping" approach.

The two-line running page header at the top of each page tells you:

- Name of the manual
(OrderpickerModel 7BPUE15 Service Manual)
- Current Chapter Title
(e.g., this page How to Use ***This*** Manual)
- Current topic
(e.g., this page Manual Design)

We suggest turning to the **START** page first when you use this manual.

The **START** page asks a few simple questions to guide you to the proper chapter.

- **How to Use This Manual** explains the manual format and design and contains the Table of Contents and **START** page.
- **Safety** explains warning and caution notes, general safety rules and safety rules for batteries, static, jacking, and welding.
- **Systems Overview** includes truck dimensions and specifications.
- **Planned Maintenance** outlines the recommended schedule of preventive services to keep your truck working most efficiently.
- **Troubleshooting** is a set of "decision-tree" charts designed to take you from a symptom to a specific sequence of tests in order to isolate a failing component.
 - The **START TROUBLESHOOTING** chart (on Page 5-27) will guide you to the individual troubleshooting symptom chart you need.

- Once you're familiar with the symptoms listed, you may instead simply find the symptom chart from the **Troubleshooting Flowcharts** (Page 5-27).
 - When you complete a troubleshooting procedure, be sure to follow the steps in **End of Troubleshooting Chart END-1** (Page 5-28).
 - **Codes and Tests** lists the electrical fault codes and procedures for running firmware electrical tests.
 - **Component Procedures** gives step-by-step procedures for testing, removal, installation, and adjustment of individual truck components. Components are grouped by truck system.
- To find a component procedure, you may use one of three methods:
- Look up the component name in the List of **Component Procedures** (Page 7-1).
 - Find the component in the **Component Locator Photos** (Page 7-5).
 - Look up the component name in the Service Manual **Index** (Page I-1).
 - **Theory of Operations** explains signal flow within hydraulic and electrical schematics for various conditions of truck operation.
 - **Appendix** contains reference information such as torque values, lubrication specifications, and system schematics.
 - **Index** lists subjects alphabetically.

Page Revision Page

This section is a record of all revised pages in this manual. Whenever a page is revised, this section is updated and included in the revision package. This lets you keep track of the latest revised pages for this manual.

Original Issue - No Changes

General Safety

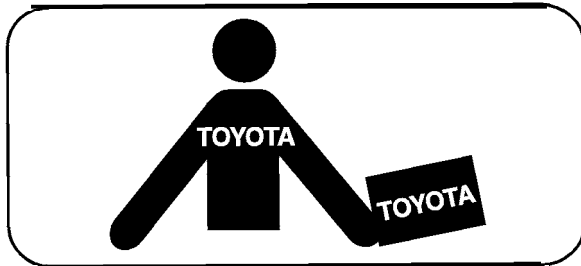

Do NOT operate or work on this truck unless you are trained, are qualified and authorized to do so, and you have read the Owner/Operator Manual.

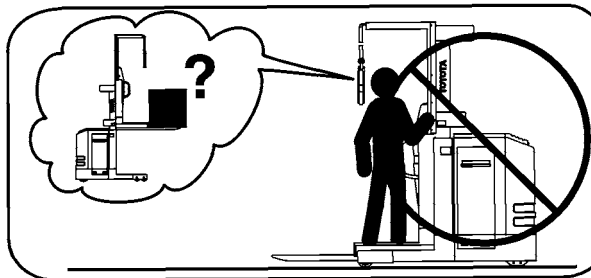

Know the truck's controls and what they do.

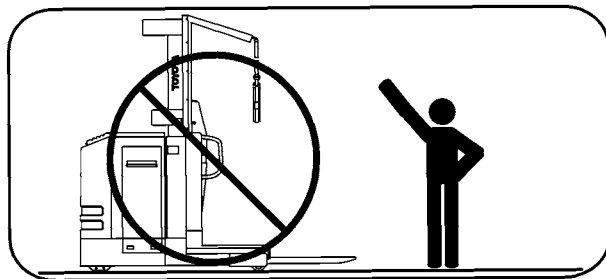

Do NOT operate this truck if it needs repair or if it is in any way unsafe.

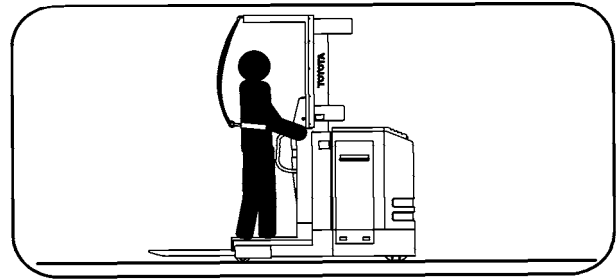

Operate this truck only from the operator's position. When elevated, be sure to wear a safety belt attached to a secured tether.

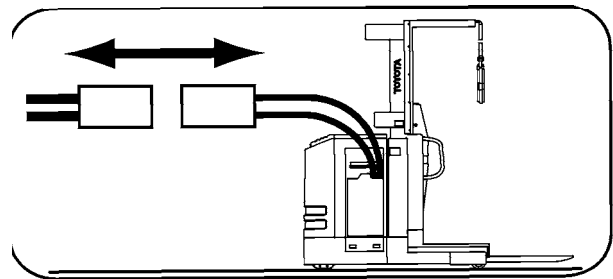

Before working on this truck, always turn the key switch OFF and disconnect the truck's battery connector (unless this manual tells you otherwise).

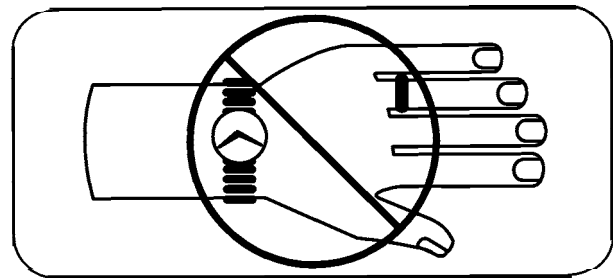

Do NOT wear watches, rings, or jewelry when working on this truck.

General Safety

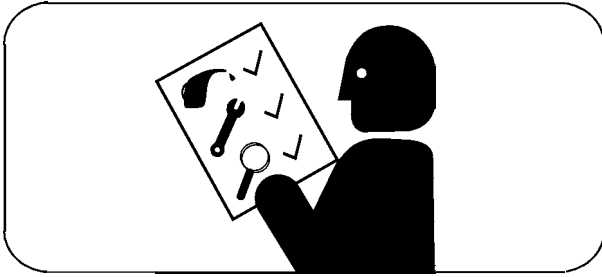

Follow the scheduled lubrication, maintenance and inspection steps.

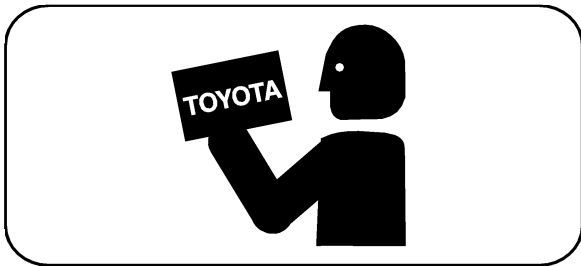

Follow exactly the safety and repair instructions in this manual. Don't take "shortcuts".

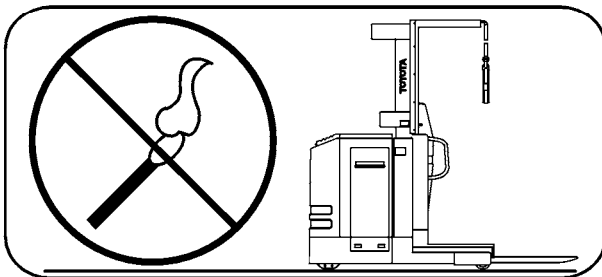

Do NOT use an open flame near the truck.

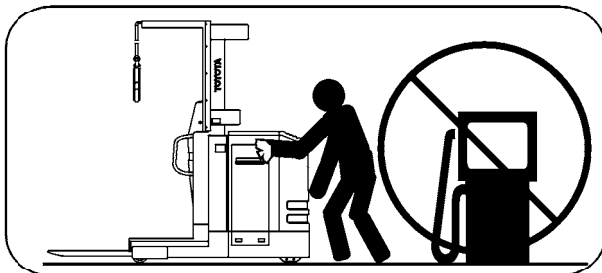

Do NOT use gasoline or other flammable liquids for cleaning parts.

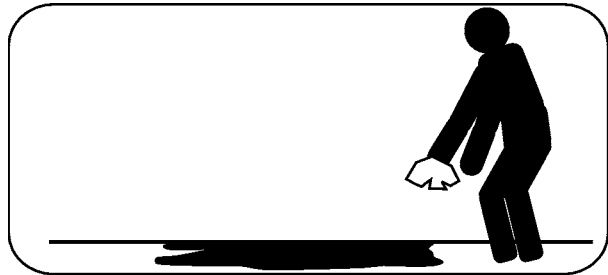

Clean up any hydraulic fluid, oil or grease that has leaked or spilled on the floor.

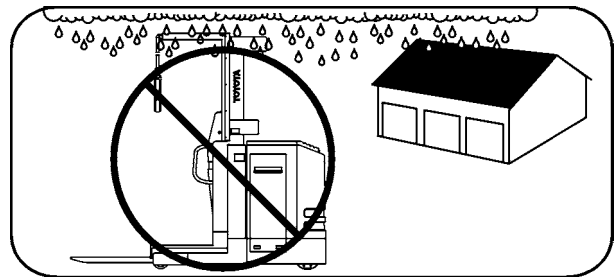

Always use and park this truck indoors.

Do NOT park a truck in a cold storage area overnight unless the truck is conditioned for cold storage.

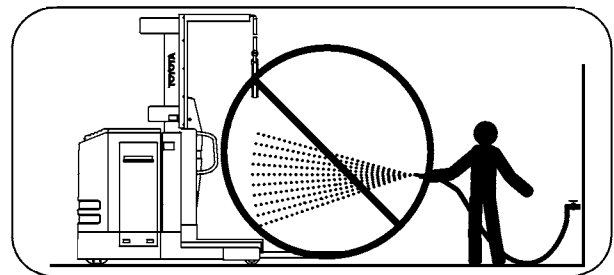

Do NOT wash this truck with a hose.

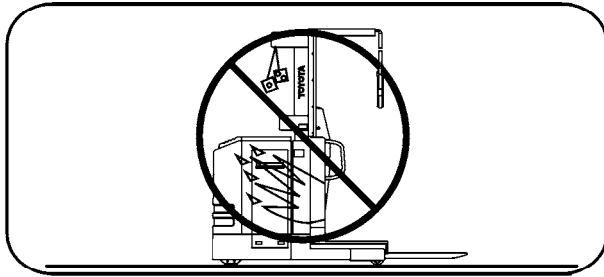

Do NOT add to or modify this truck until you contact your authorized Toyota Dealer to receive written manufacturer approval.

Battery Safety

Battery Safety**⚠ WARNING**

As a battery is being charged, an explosive gas mixture forms within and around each cell. If the area is not properly ventilated, this explosive gas can remain in or around the **battery** for several hours after charging. Be sure there are no open flames or sparks in the charging area. An open flame or spark can ignite this gas, resulting in serious damage or injury.

⚠ WARNING

Battery electrolyte is a solution of sulfuric acid and water. Battery acid causes burns. Should any electrolyte come in contact with your clothing or skin, flush the area immediately with cold water. Should the solution get on your face or in your eyes, flush the area with cold water and get medical help immediately.

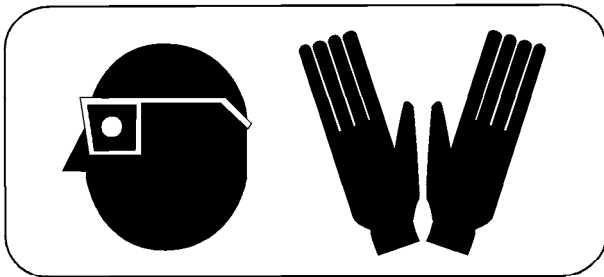

Wear personal protective equipment to protect eyes, face and skin when checking, handling or filling batteries. This equipment includes

goggles or face shield, rubber gloves (with or without arm shields) and a rubber apron.

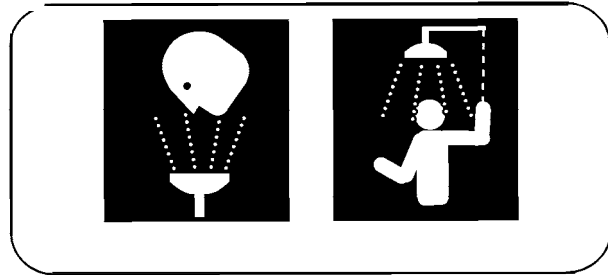

Make sure a shower and eyewash station are nearby in case there is an accident.

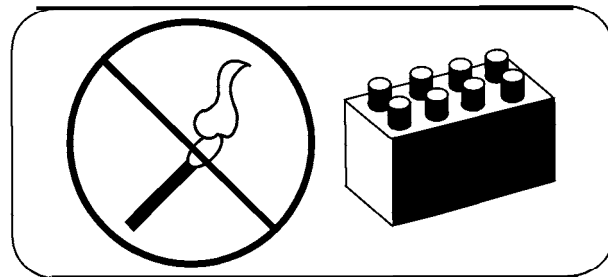

A battery gives off explosive gases. NEVER smoke, use an open flame, or use anything that gives off sparks near a battery.

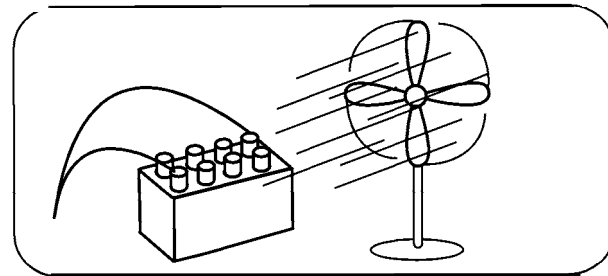

Battery Safety

Keep the charging area well-ventilated to avoid hydrogen gas concentration.

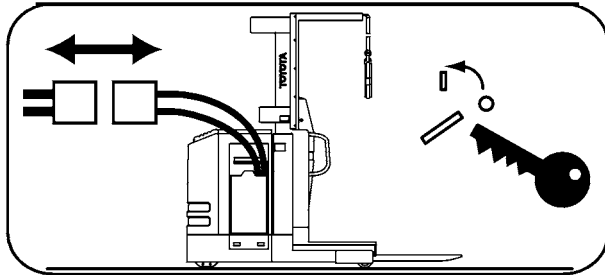

Turn the key switch OFF before disconnecting the battery from the truck at the battery connector. Do not break live circuits at the battery terminals. A spark often occurs at the point where a live circuit is broken.

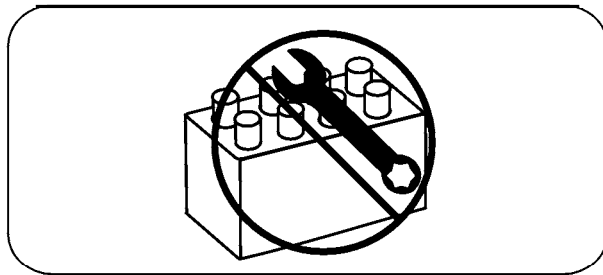

Do not lay tools or metal objects on top of the battery. A short circuit or explosion could result.

Keep batteries clean. Corrosion causes shorts to the frame and possibly sparks.

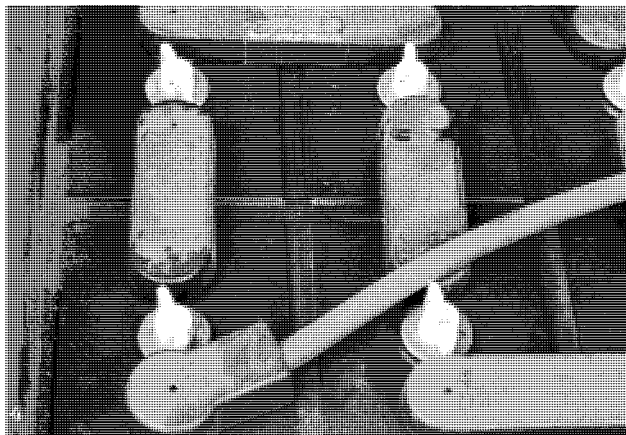

Keep plugs, terminals, cables and receptacles in good condition to avoid shorts and sparks.

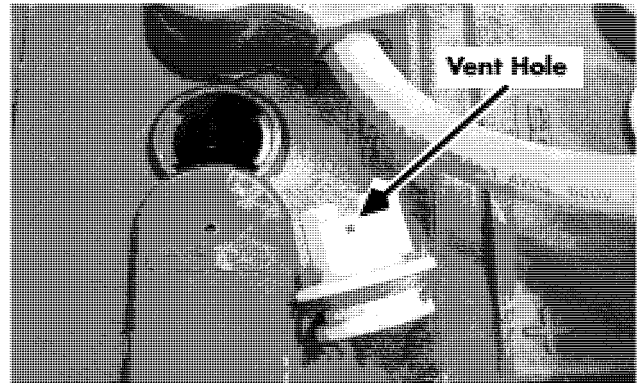

Keep filler plugs firmly in place at all times except when the electrolyte level is checked, when water is added to the cells or when the specific gravity is checked.

Make sure the vent holes in the filler plugs are open to allow the gas to escape from the cells.

Do not allow cleaning solution, dirt or any foreign matter to enter the cells.

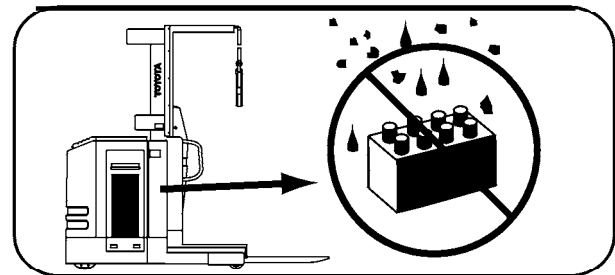

Make sure you install the correct size battery. A smaller or lighter weight battery could seriously affect truck stability. See the truck's specification plate for more information.

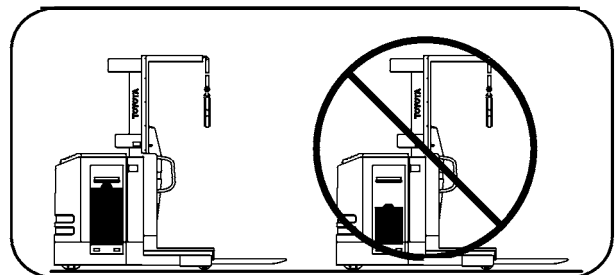

Battery Safety

Never plug a battery charger into the truck's battery connector. Plug the battery charger only into the battery connector from the battery.

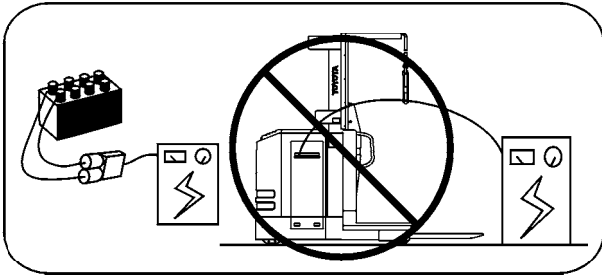

Follow the charging procedures in the Battery Instruction Manual and in the Battery Charger Instruction Manual.

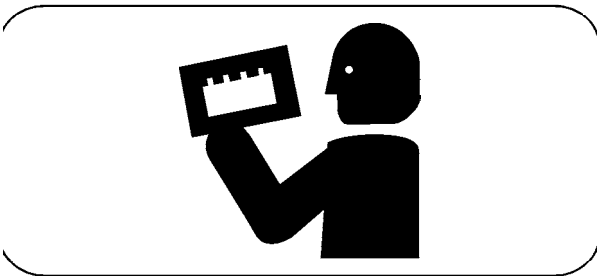

Static Safety

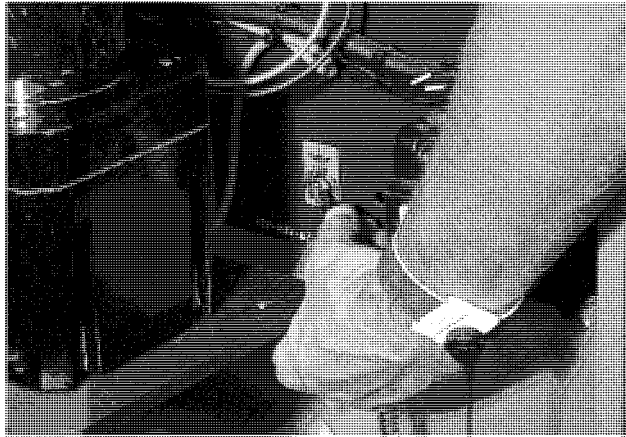

Figure 2-1. ESD Plug On Tractor

Electronic circuit boards and devices used on this truck can be damaged by the discharge of static electricity, called electrostatic discharge.

Static charges can accumulate from normal operation of the truck as well as movement or contact between non-conductive materials (plastic bags, synthetic clothing, synthetic soles on shoes, styrofoam coffee cups, etc.).

Accumulated static can be discharged through human skin to a circuit board or component by touching the parts. Static discharge is also possible through the air when a charged object is placed close to another surface at a different electrical potential. **Static discharge can occur without you seeing or feeling it.**

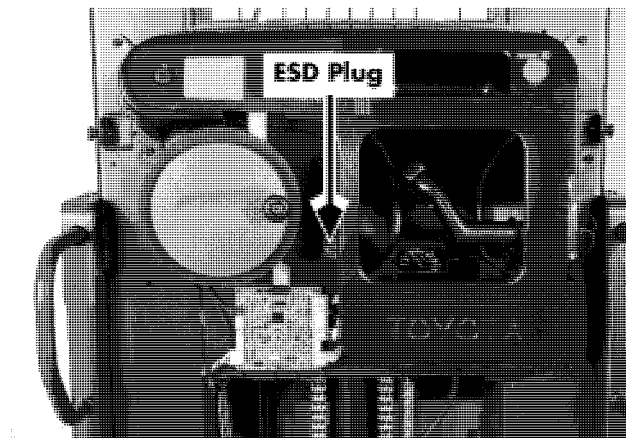

Figure 2-2. ESD Plug on Operator Console

Whenever working on or near static-sensitive electronics, always use static discharge precautions.

1. Place a static discharge wrist strap around your wrist. Connect the ground lead to the wrist strap connector.
2. Plug the ground cord into the ESD plug on the electrical assembly panel or the console panel. See Figure 2-1 and Figure 2-2.
3. Before removing or installing static-sensitive components, place them on a properly grounded static mat. See Figure 2-3.
4. To transport static-sensitive components, including failed components being returned place the components in an anti-static bag or box (available from your Toyota Dealer).

The wrist strap and associated accessories should be tested monthly to verify they are working properly. A bad static discharge wrist band will not alert you that it is bad.

Figure 2-3 shows the components of the Toyota anti-static field service kit, part number 00590-04849-71. The kit includes a wrist strap, ground cord and static-dissipative work surface (mat). Follow the instructions packaged with this kit.

Static Safety

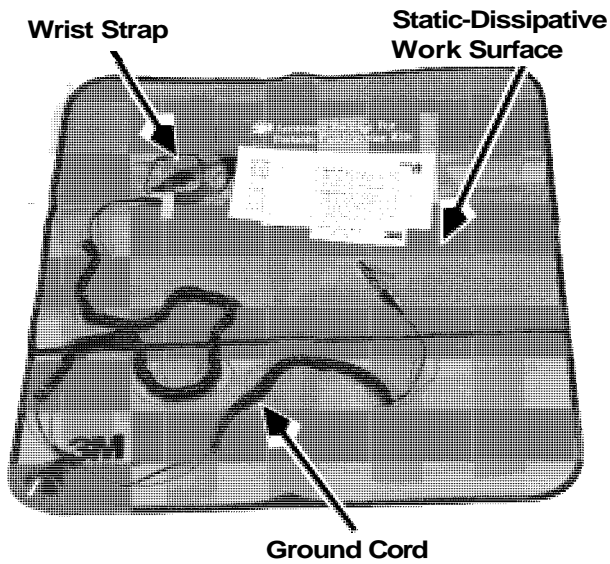

Figure 2-3. Anti-Static Kit With Wrist Strap and Mat

Wrist straps are available in quantities of 25, as part number 00590-04848-71.

A wrist strap tester is available as part number 00590-04850-71.

Contact your authorized Toyota Dealer for information.

Jacking Safety

Sometimes you may need to jack the truck up from the floor to perform maintenance procedures. When doing so, observe the proper safety precautions:

1. Lower the forks completely. Remove any load.
2. Place all controls in neutral.
3. Block the wheels to prevent movement of the vehicle.
4. Disconnect the battery connector.
5. Place the jack under the designated jacking points listed in the following procedures.

⚠ WARNING

Use extreme care whenever the truck is jacked up. Keep hands and feet clear from the vehicle while jacking the truck. After the truck is jacked, place solid blocks beneath it to support it. DO NOT rely on the jack alone to support the truck.

Operator Platform

1. Using the lift button, raise the operator platform until you have enough clearance for your procedure.
2. Place a safety stand or block between the carriage and a baseleg and carefully lower the operator platform onto the safety stand.
3. Turn the key switch OFF and disconnect the battery.

Tractor

⚠ CAUTION

Use care when jacking the tractor on wire-guided trucks. Sensors are installed under the bumper. See Figure 2-4.

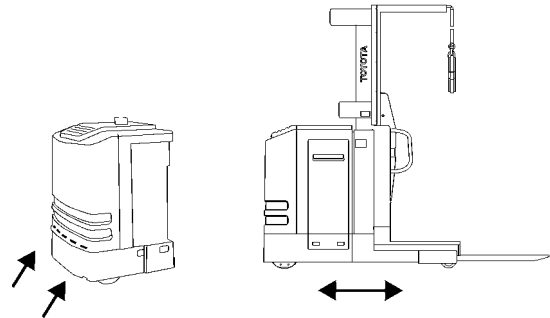

Only jack in these areas, no more than 1/2 in. (13mm) off the floor.

Figure 2-4. Tractor Jacking Points

1. Place the jack at the designated jacking point. See Figure 2-4.
2. Jack one side of the truck so that the drive tire is off the floor approximately 1 inch (25.4 mm).
3. Block that side of the truck in place.
4. Jack up the other side of the truck level with the first side.
5. Block that side of the truck in place.

NOTE: After working on a vehicle, test all controls and functions to assure proper operation.

Jacking Safety

Baseleg

Figure 2-5. Baseleg Jacking Points

1. Place the jack at the designated jacking point. See Figure 2-5.
2. Jack the baseleg until you have enough clearance to replace the load wheel.

Tie-Down for Transport

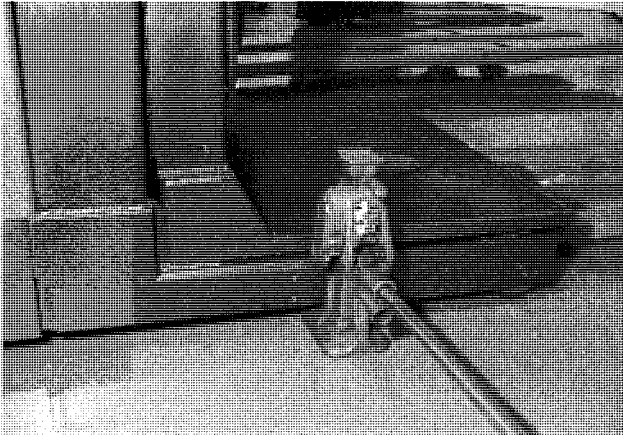
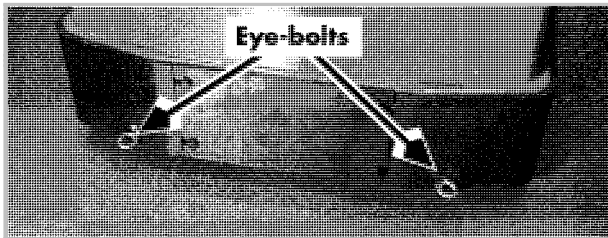

Figure 2-6. Eye-Bolts Installed for Transport

Vertical Transport

To transport this lift truck in an over-the-road vehicle or rail car, follow these steps:

1. Lower operator platform and locate truck in center of transport vehicle.
2. Turn key switch OFF and disconnect battery.

NOTE: If guide rollers are present, place straps through guide rollers and secure to floor; proceed to step 4.

3. If guide rollers (used for rail guidance) are not present:

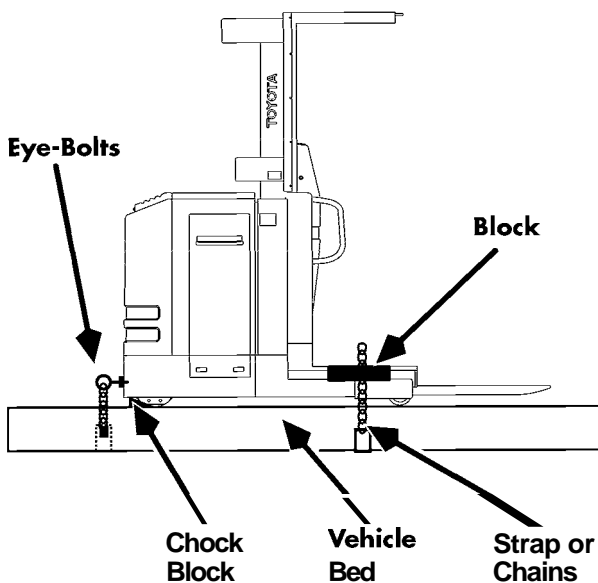

Figure 2-7. Tie-Down for Vertical Transport

- a. Install eye-bolts (3/4 in. [19 mm] thread size) in holes in the bumper. See Figure 2-6.
 - b. **Secure** chain from eye-bolts to vehicle bed. See Figure 2-7.
4. **Stop** truck **from bumper** or **guide roller** to floor of transport vehicle. See Figure 2-7
 5. **Chock** drive wheel to **prevent tractor-first** movement. See Figure 2-7.
 6. Place block **between baseleg and platform**, 7.5 in. (190.5 cm) from front edge of platform. See Figure 2-7.
 7. Position additional adjustable chain or strap perpendicular to forks over operator's platform and attach it to vehicle bed. This will prevent tip-over during transportation. See Figure 2-7.

Horizontal Transport

1. Remove forks from carriage.
2. Replace cap and screen in hydraulic reservoir with shipping cap and screws.
3. Band down carriage and battery rollers.
4. Remove dipstick, and plug drive unit.
5. Remove the bottom two bumper plate bolts (to be replaced during shipping).
6. Use two hoists in conjunction and lay truck on cradle.
7. Install long bolts through the holes in the bumper and secure to cradle.
8. Band truck to cradle.
9. Secure forks to cradle below mast.

Towing a Disabled Unit

Towing a Disabled Unit

To safely tow a Toyota Orderpicker:

1. Lower the operator platform and remove any load.
2. Turn the key switch OFF and disconnect the battery connector.
3. Using a suitable towing vehicle, lift the tractor end of the truck until the drive tire is no more than 1 inch (25.4 mm) off the floor.
4. Tow the truck slowly in the tractor-first direction.

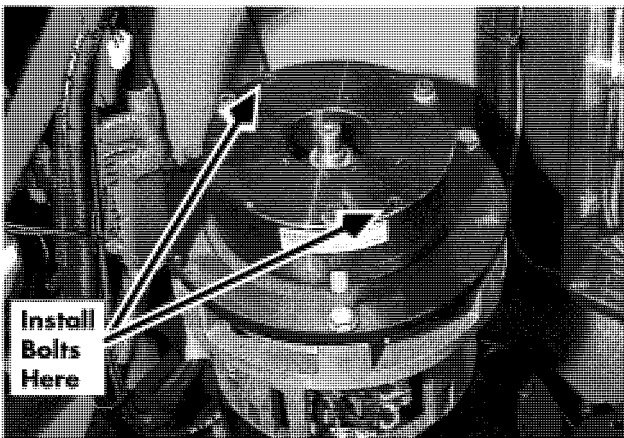

Figure 2-8. Location For Release Bolts In Brake

NOTE: If you must tow the truck flat on the ground, you must install the brake

release bolts provided. See Figure 2-8 and Figure 2-9.

Steering is disabled while you are towing, so you will need to manually turn the drive unit to steer.

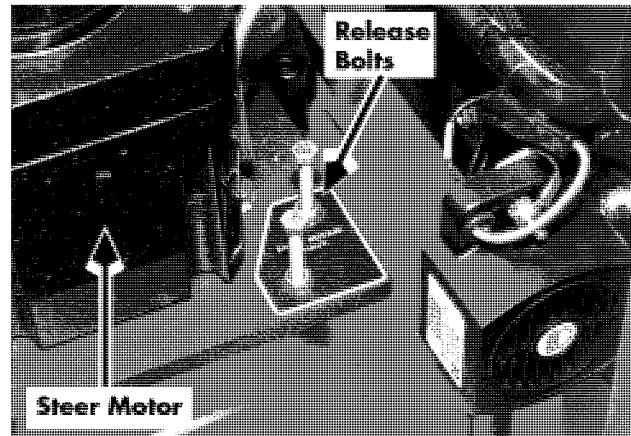

Figure 2-9. Brake Release Bolts

Welding Safety

⚠ WARNING

Flame cutting or welding on painted surfaces may produce potentially harmful fumes, smoke and vapors. Prior to performing flame cutting or welding operations, it is recommended that the coating be removed in the vicinity where the **operation(s)** will be performed.

⚠ WARNING

Coating removal may be by mechanical methods, chemical methods or a combination of methods. Flame cutting and/or welding operations should be carried out only in well ventilated areas using local exhaust if necessary.

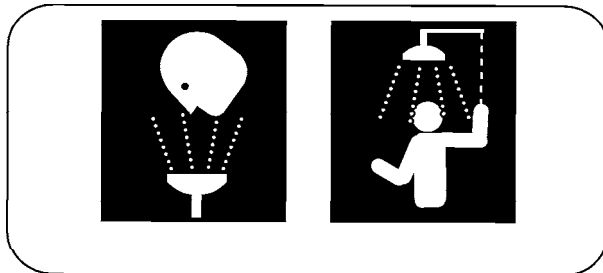

Before working on this truck, make sure that:

- Fire protection equipment is nearby.
- You know where the nearest eyewash station is.

⚠ CAUTION

Disconnect the battery before you attempt to inspect, service or repair the lift truck. Discharge residual charge in the traction power amplifier by pressing in the PC and P contactors at the same time.

- Check for any shorts to the frame as described on page 5-4. If any shorts are detected, remove them before you proceed with the welding operation.
- Clean the area to be welded.
- Protect all truck components from heat, weld spatter and debris.
- Attach the ground cable as close to the weld area as possible.
- Do not perform any welding operation near the electrical components.
- If welding must be done near the battery compartment, remove the battery.
- When you are finished welding, perform all ground tests and electrical inspections before the vehicle is operated.



Download the full PDF manual instantly.

Our customer service e-mail:

aservicemanualpdf@yahoo.com