

**TM608819 - 6100D, 6110D, 6115D, 6125D and 6130D(Tier 0 –Tier 3/Stage IIIA)
Tractors Repair Technical Manual(60000—), 11/2014—
Remove and Install Final Drive Assembly**

Remove and Install Final Drive Assembly

1. *NOTE:*

*It is not necessary to remove fuel tank, but doing so may ease removal and installation of left-hand final drive.
(See Remove and Install Fuel Tank in Section 30, Group 05.)*

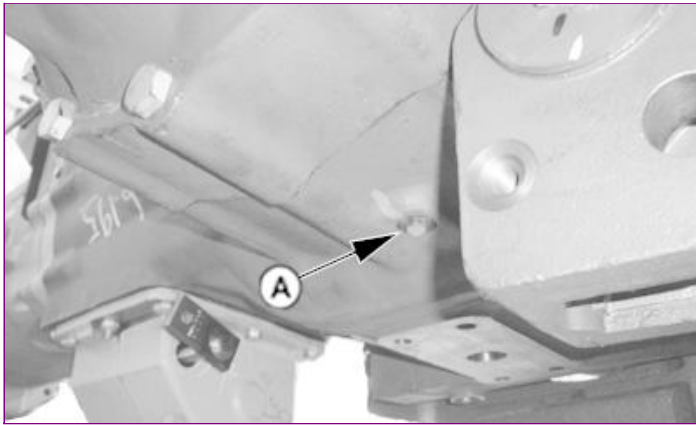

PUC2088-UN: Final Drive Drain

LEGEND:

A - Drain Plug

Remove final drive drain plug (A) to drain oil into suitable container.

2. Install drain plug (A).
-

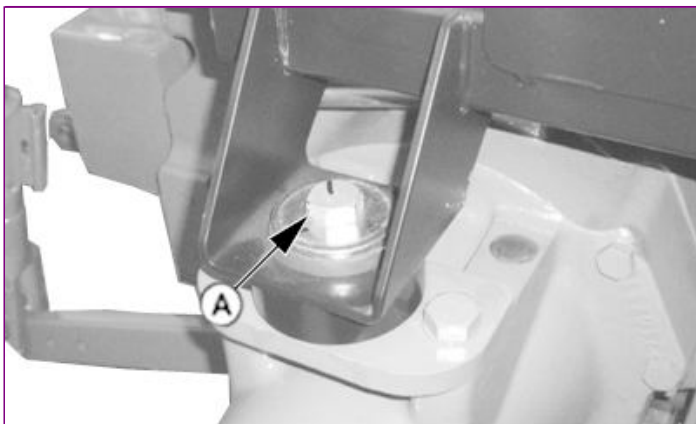

3. PUC2208-UN: .

LEGEND:

A - Cap Screw (4 used)

Loosen the cab mounting cap screws. Remove cap screw (A) while removing final drive housing.

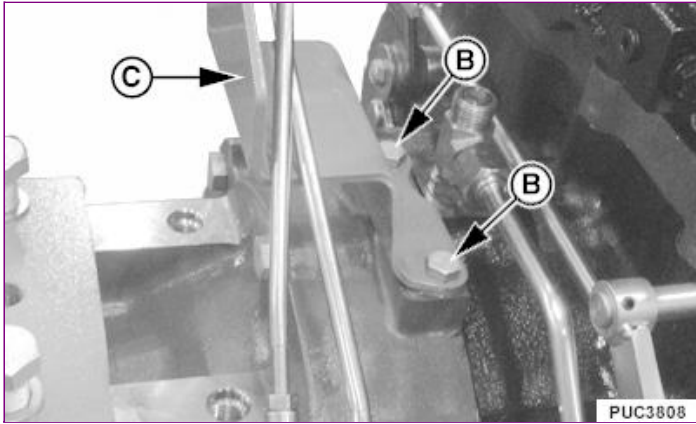

4. PUC3808-UN: Right-Hand Side Half Axle

LEGEND:

- B - Screw (2 used)
- C - SCV Mounting Bracket

Loosen SCV mounting bracket (C) by removing cap screws (B) while removing final drive housing.

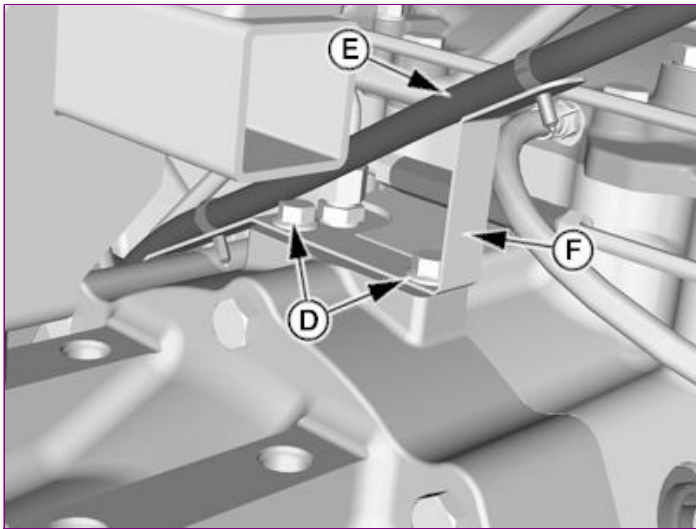

5. PY20649-UN: Left Hand Side Half Axle

LEGEND:

- D - Cap Screws
- E - Transmission Harness
- F - Bracket

Loosen transmission harness bracket (F) by removing cap screws (D) while removing the final drive housing.

6.



CAUTION:

Prevent bodily injury caused by accidental dropping of tractor when removing wheel. Use jack and floor stands with a minimum capacity of 4540 kg (10,000 lb.).

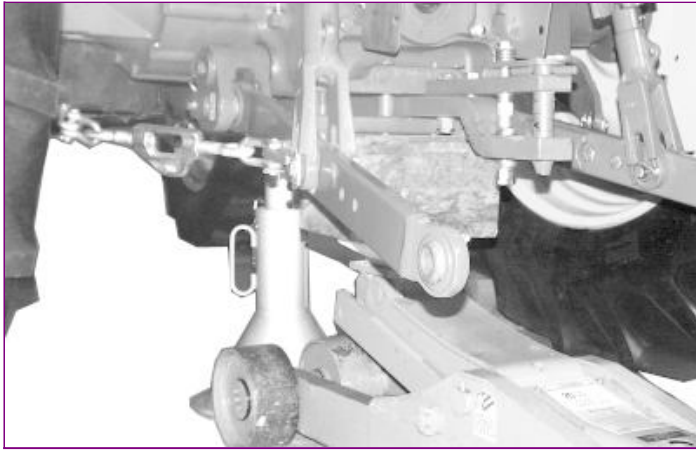

PUC2089-UN: Jacking of Tractor

Jack tractor from under drawbar support and set jack stands under front of drawbar.

7.

 **CAUTION:**

The approximate weight of the wheel and tire assembly is 260 kg (573.20 lb.).

Item	Measurement	Specification
Wheel and Tire	Weight	260 kg (573.20 lb.)

Remove left-hand wheel assembly. (See Remove and Install Front and Rear Wheels in Section 80, Group 15.)

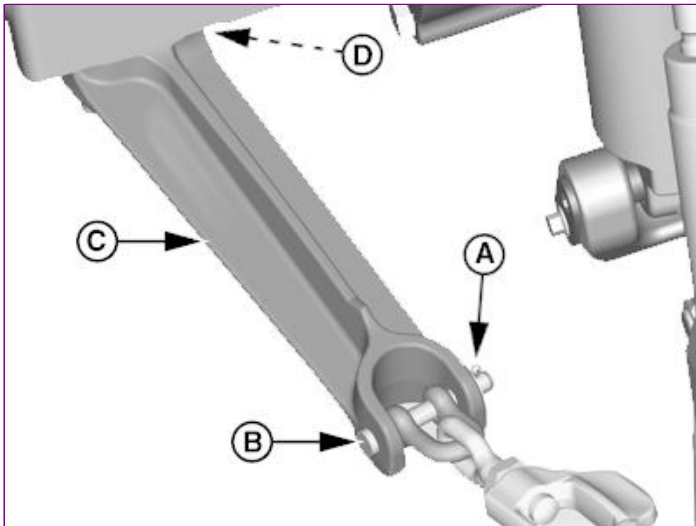

8.

PY20651-UN: .

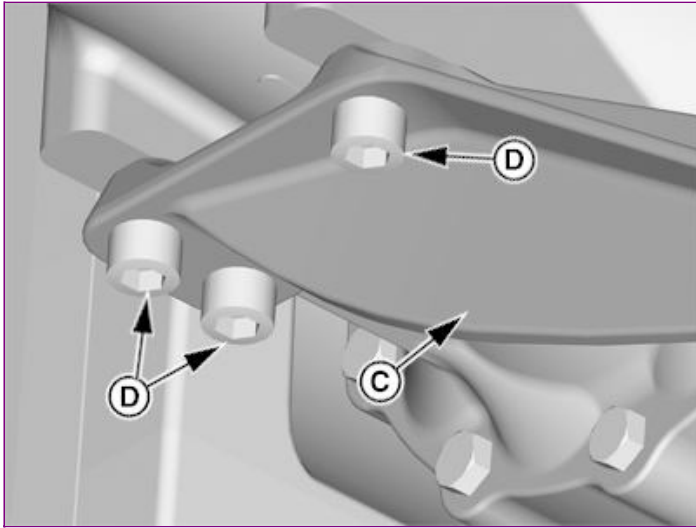

PY20650-UN: .

LEGEND:

- A - Cotter Pin
- B - Pin
- C - Bracket, Link Arm
- D - Cap Screw (3 used)

Remove cotter pin (A) and pin (B).

9. Remove cap screws (D) and link arm bracket (C).

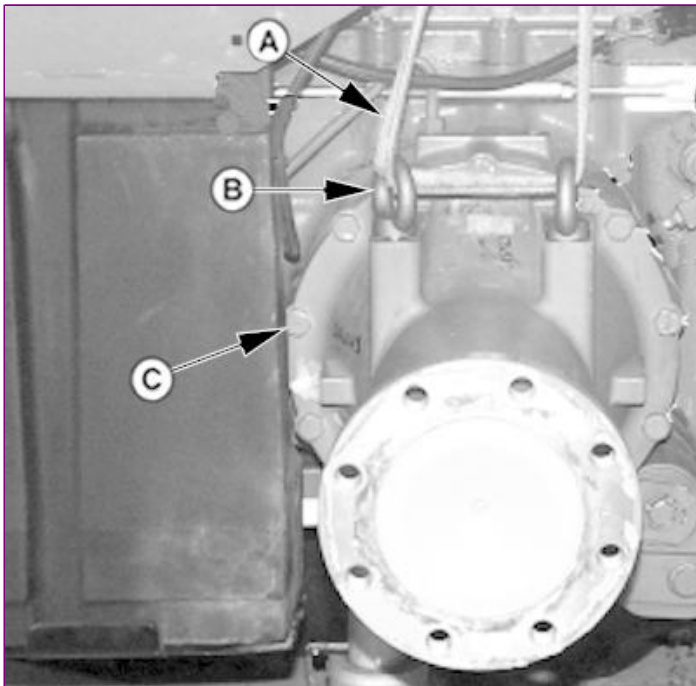

10. PUC2092-UN: .

LEGEND:

- A - Lifting Device
- B - Eyebolt (2 used)
- C - Cap Screw (10 used)

Install eyebolts (B) into existing holes.

11. Attach a suitable lifting device (A).
12. Remove cap screws (C) and final drive from transaxle.



13. PUC2093-UN: Final Drive Axle

Remove pinion shaft.

14. Inspect all parts for wear or damage. Replace as necessary.
15. Install pinion shaft.

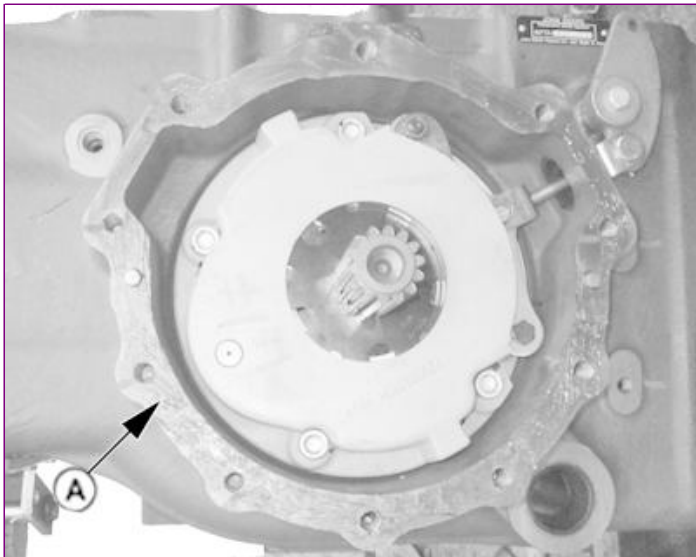

16. PUC2094-UN: Final Drive Mating Surface

LEGEND:

A - Transaxle Housing

Clean mating surfaces of final drive and transaxle housing (A) using TY16285 Cure Primer.

17. Apply TY6304 Flexible Sealant to mating surfaces.

18. **NOTE:**

Gently rotate axle while positioning the final drive pinion into the planetary gears.

Install final drive assembly onto transaxle housing.

19. **NOTE:**

Tighten all cap screws, using a crisscross pattern, when housings are mated.

Tighten cap screws to specification.

Item

Measurement

Specification

Final Drives

Final Drive Assembly Cap Screw Torque

345 N·m
(255 lb.-ft.)

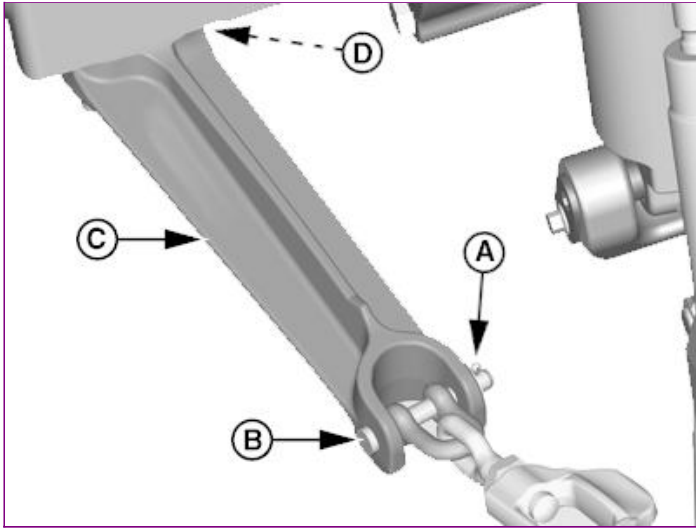

20. PY20651-UN: .

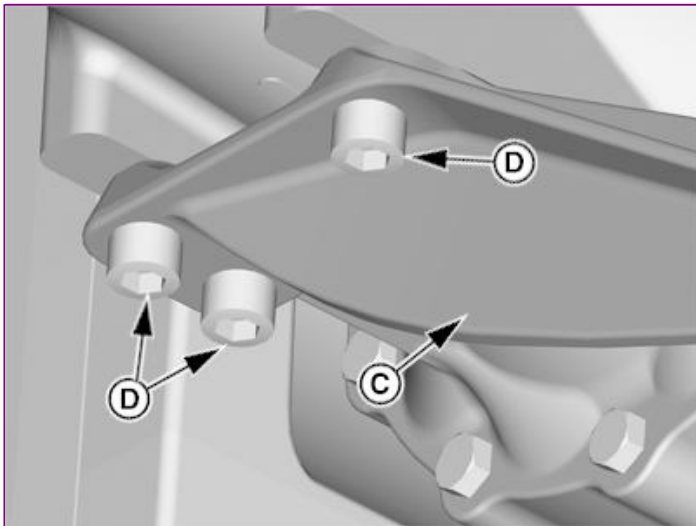

PY20650-UN: .

LEGEND:

- A - Cotter Pin
- B - Pin
- C - Bracket, Link Arm
- D - Cap Screw (3 used)

Install link arm bracket (C) and cap screws (D).

21. Install pin (B) and cotter pin (A).

22.



CAUTION:

The approximate weight of the wheel and tire assembly is 260 kg (573.20 lb.).

Item	Measurement	Specification
Wheel and Tire	Weight	260 kg (573.20 lb.)

Install wheel assembly. (See Remove and Install Front and Rear Wheels in Section 80, Group 15.)

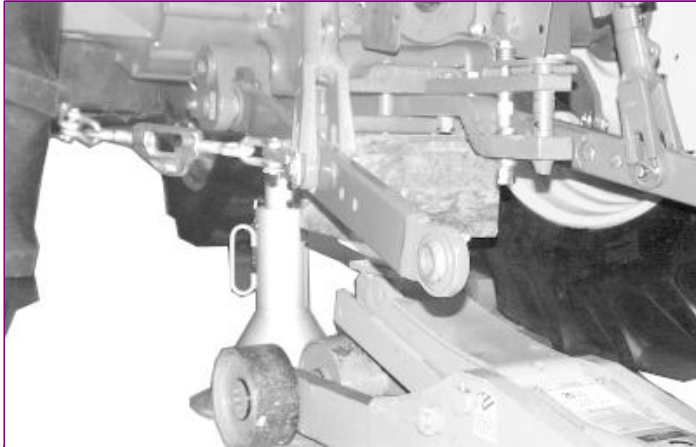

23. PUC2089-UN: Jacking of Tractor

Raise tractor using a floor jack under drawbar support; then remove jack stands under front of drawbar.

24. Install fuel tank if previously removed. (See Remove and Install Fuel Tank in Section 30, Group 05.)
-

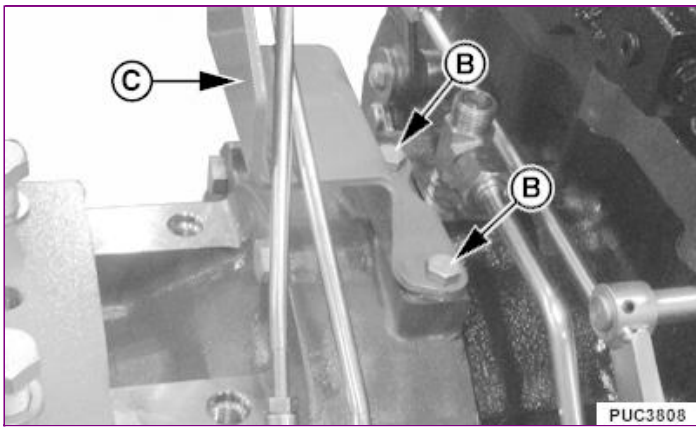

25. PUC3808-UN: Right-Hand Side Half Axle

LEGEND:

- B - Screw (2 used)
- C - SCV Mounting Braket

Install screws (B) to install SCV bracket mounting (C).

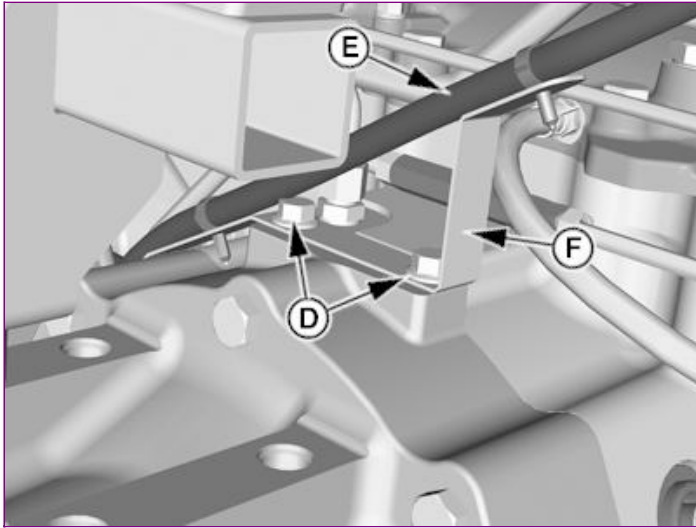

26. PY20649-UN: Left Hand Side Half Axle

LEGEND:

- D - Cap Screws
- E - Transmission Harness
- F - Bracket

Install cap screws (D) to install transmission harness bracket (F).

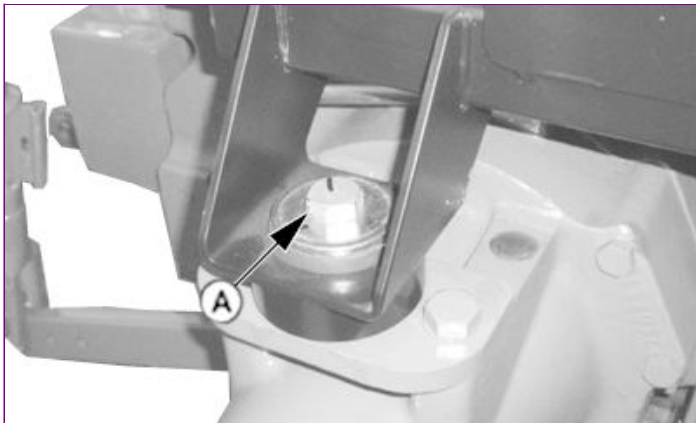

27. PUC2208-UN: .

LEGEND:

- A - Cap Screw (4 used)

Install cab mounting cap screws (A). Tighten to specification.

Item	Measurement	Specification
Cab Mounting Cap Screw	Torque	610 N·m (450 lb.-ft.)

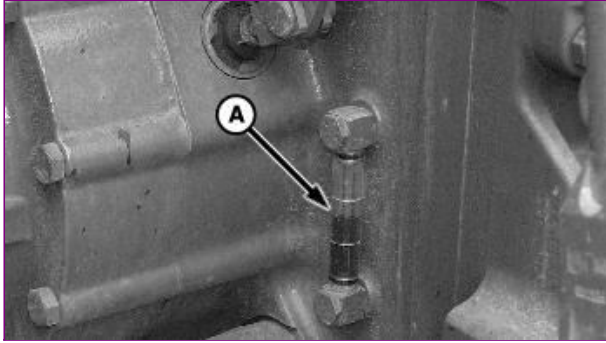

28. P9073-UN: Sight Glass

LEGEND:

A - Sight Glass

Fill transaxle housing until fluid level is visible between two marks on sight glass (A) with specified transmission/hydraulic oil. (See Section 10 for recommended oil.)

29. Start engine and run for 5 min.
30. Shut off engine and wait 5 min. before rechecking oil level in sight glass.
31. Add additional oil as necessary.

TM608819 - 6100D, 6110D, 6115D, 6125D and 6130D(Tier 0 –Tier 3/Stage IIIA) Tractors Repair Technical Manual(60000–), 11/2014– Remove, Inspect and Install MFWD Drive Shaft

Remove, Inspect and Install MFWD Drive Shaft

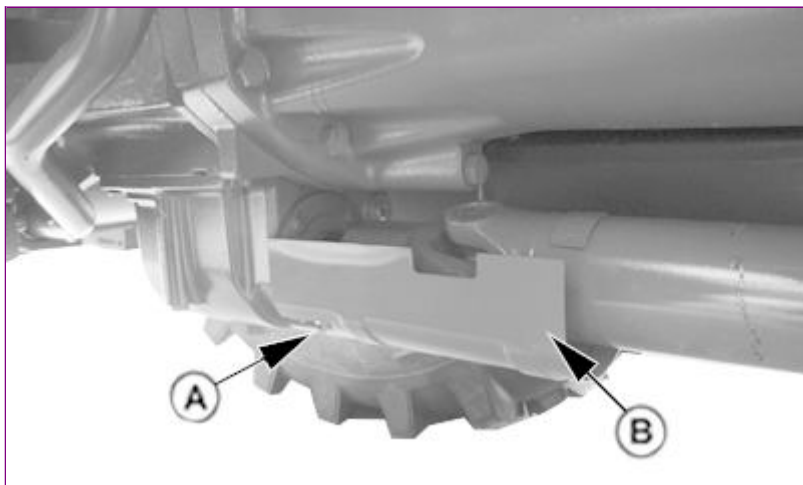

1. PUC2096-UN: Rear Shield

LEGEND:

- A - Cap Screw (2 used)
- B - Shield

Loosen cap screws (A) and remove rear shield (B).

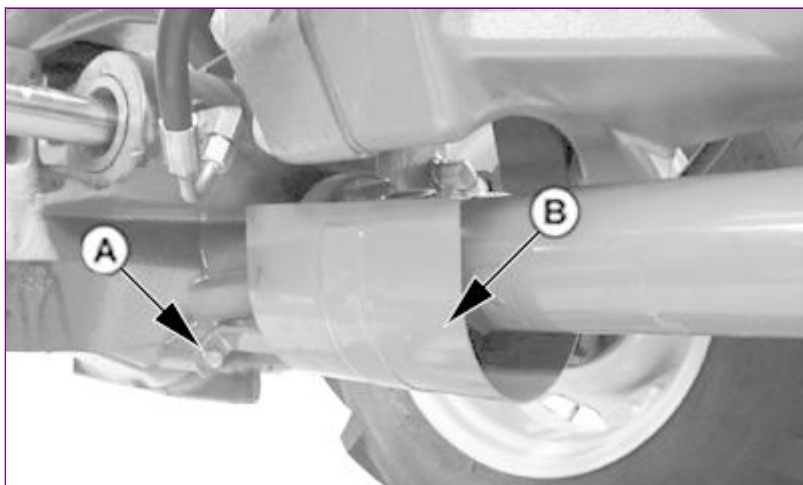

2. PUC2097-UN: Front Shield

LEGEND:

- A - Cap Screw (2 used)
- B - Shield

Remove cap screws (A) and front shield (B).

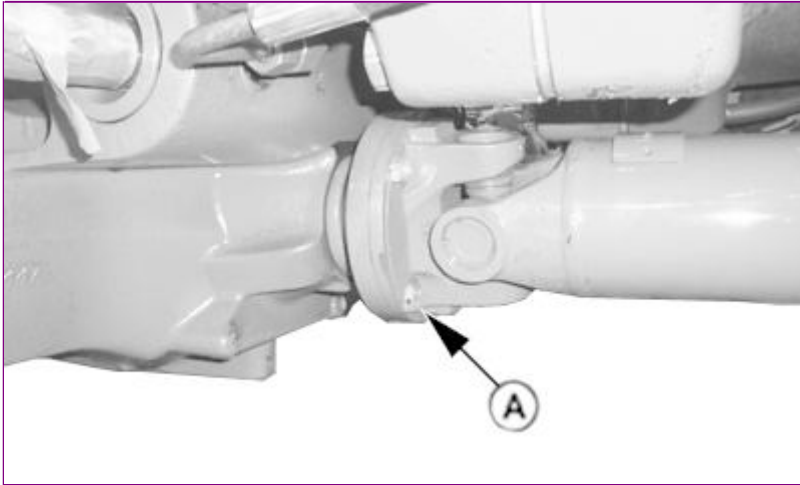

3. PUC2098-UN: Cap Screw

LEGEND:

A - Cap Screw (4 used)

Remove cap screws (A) and lower shaft to ground. Slide drive shaft off splined output shaft of MFWD drop gearbox.

4. Inspect for wear or damage. Check drive shaft for straightness. Replace as necessary.
5. Apply TY6341 Multi-Purpose SD Polyurea Grease to internal splines of drive shaft end.
-

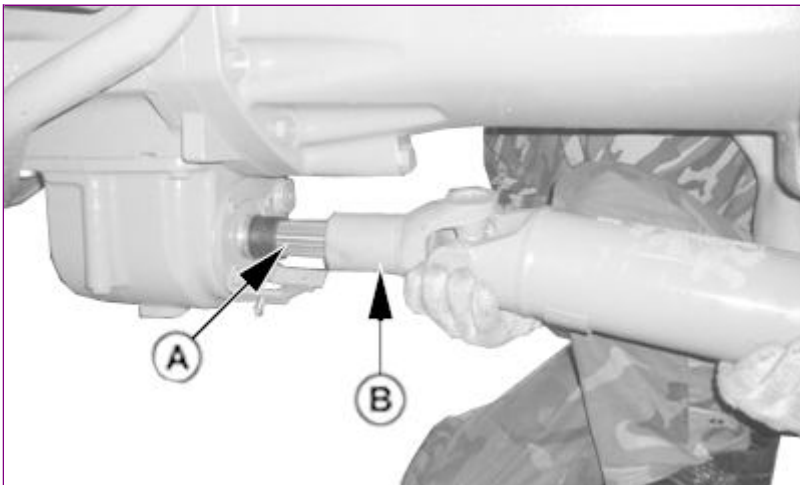

6. PUC2099-UN: Drive Shaft

LEGEND:

A - MFWD Output Shaft
B - Drive Shaft

Install drive shaft (B) onto MFWD output shaft (A).

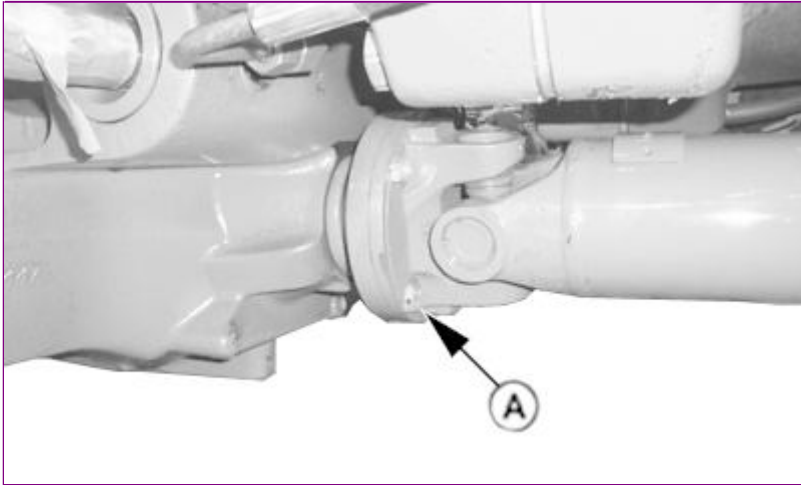

7. PUC2098-UN: .

LEGEND:

A - Cap Screw (4 used)

Install flange to shaft using cap screws (A).

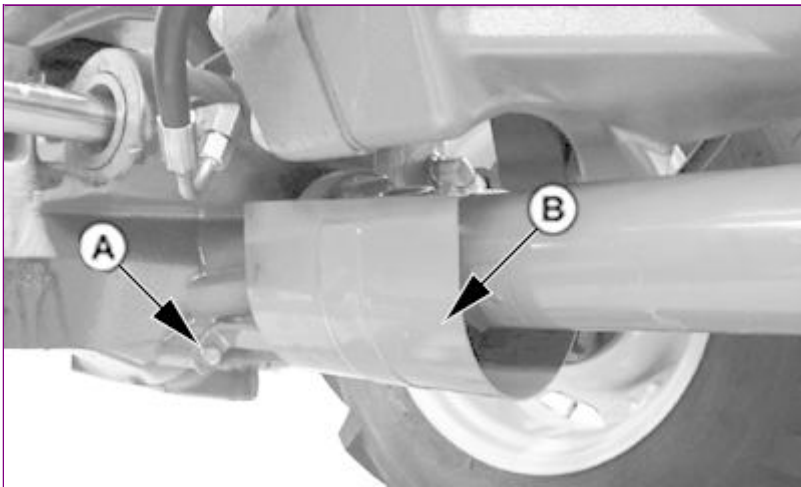

8. PUC2097-UN: Front Shield

LEGEND:

A - Cap Screw (2 used)

B - Shield

Install front shield (B) using cap screws (A).

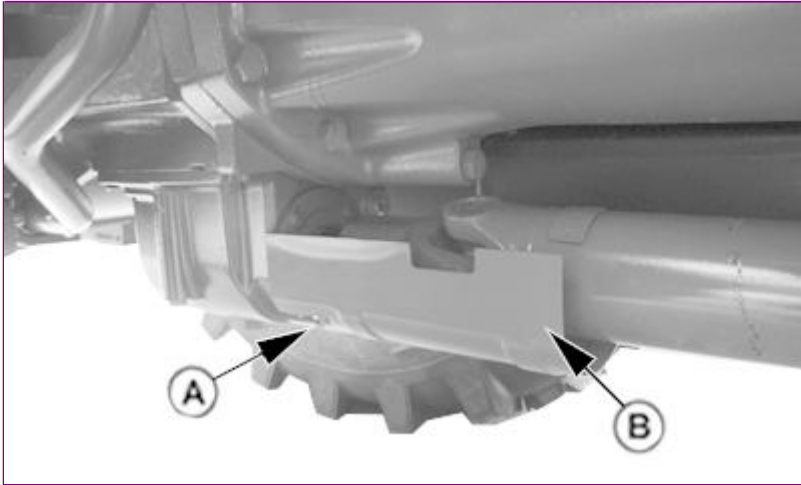

9. PUC2096-UN: Rear Shield

LEGEND:

- A - Cap Screw (2 used)
- B - Shield

Install rear shield (B) and tighten cap screws (A).

**TM608819 - 6100D, 6110D, 6115D, 6125D and 6130D (Tier 0 –Tier 3/Stage IIIA) Tractors Repair Technical Manual(60000–), 11/2014–
Remove and Install MFWD Drop Gearbox**

Remove and Install MFWD Drop Gearbox

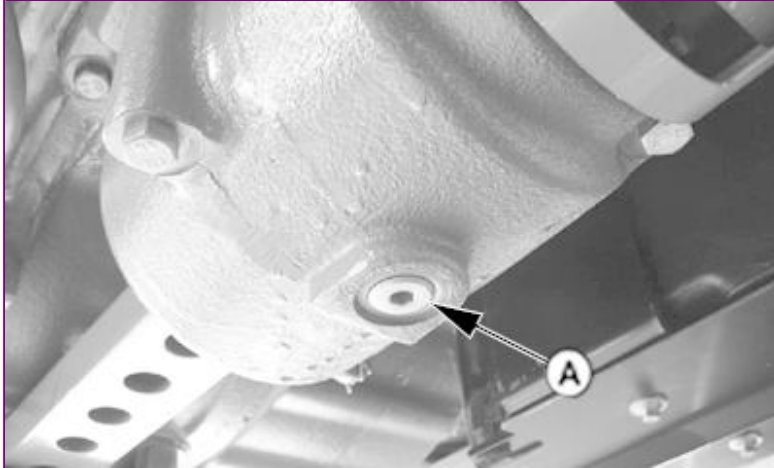

1. PUC2085-UN: MFWD Drop Box Drain

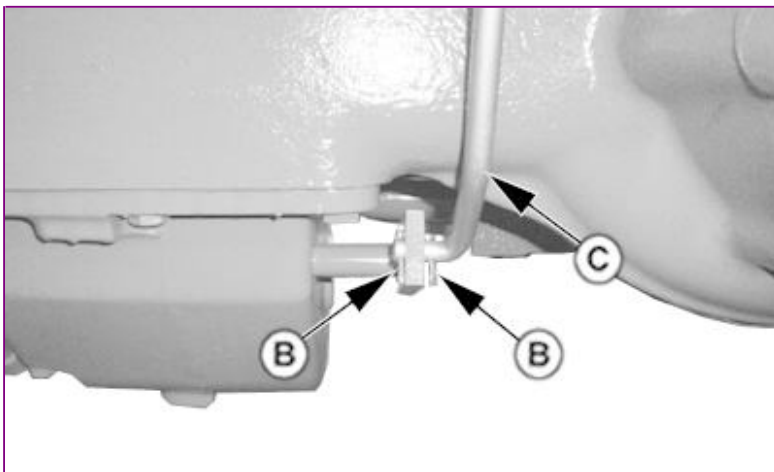

PUC2100-UN: .

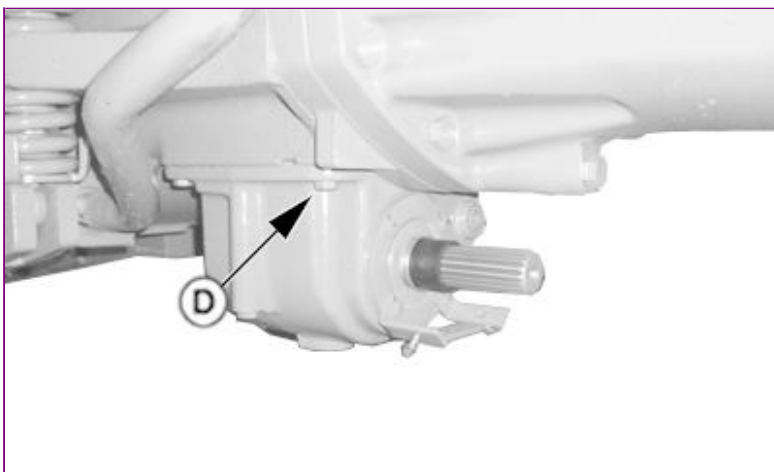

PUC2101-UN: .

LEGEND:

A - Plug, Drop Gearbox

- B - Cotter Pin (2 used)
- C - Linkage
- D - Cap Screw (8 used)

Remove drive shaft. (See Remove, Inspect and Install MFWD Drive Shaft in this group.)

2. Remove plug (A) and drain oil.
3. Remove cotter pins (B), and disconnect mechanical front wheel drive engagement linkage (C).
4. Remove cap screws (D) and remove drop gearbox.
5. Make repairs as necessary. (See procedures in this section.)
6. Clean mating surfaces of drop gearbox case and transaxle housing using TY16285 Cure Primer.
7. Apply a coat of TY6304 Flexible Form-in-Place Gasket.
8. Install drop gearbox. Tighten cap screws (D) to specification.

Item	Measurement	Specification
Drop Gearbox Mounting Cap Screws	Torque	100—150 N·m (47—111 lb.-ft.)

9. Install mechanical front wheel drive engagement linkage (C) using cotter pin (B).
10. Install drive shaft. (See Remove, Inspect and Install MFWD Drive Shaft in this group.)

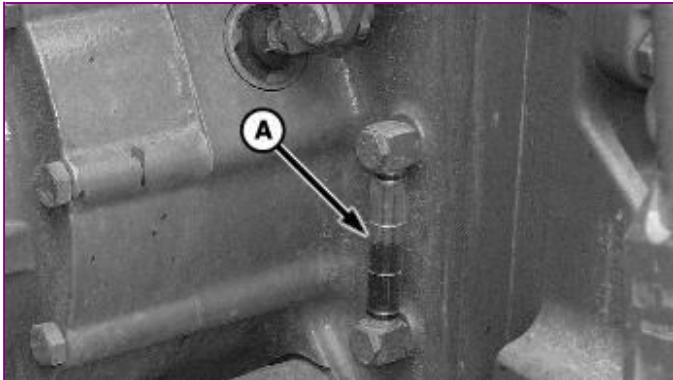

11. P9073-UN: Sight Glass

LEGEND:

- A - Sight Glass

Fill transaxle housing until fluid level is visible between two marks on sight glass (A). (See Section 10 for recommended oil.)

12. Start engine and run for 5 min.
13. Shut off engine and wait 5 min. before rechecking oil level in sight glass.
14. Add additional oil as necessary.

TM608819 - 6100D, 6110D, 6115D, 6125D and 6130D (Tier 0 –Tier 3/Stage IIIA) Tractors Repair Technical Manual(60000–), 11/2014– Split Tractor

Split Tractor

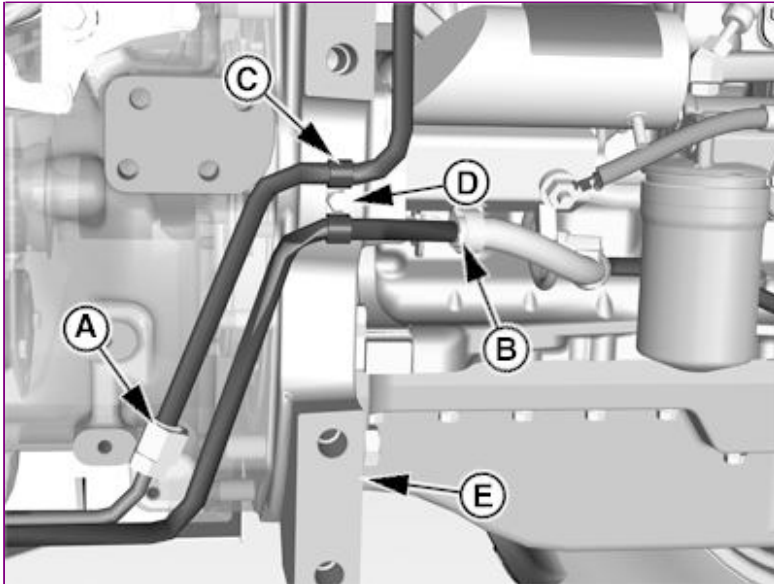

1. PY20652-UN: Steering Lines

LEGEND:

- A - Steering Line
- B - Oil Cooler Line
- C - Clamp
- D - Cap Screw
- E - Mid Frame

Block front wheels.

2. Block front wheel axle.
3. **Cab Tractor:** Remove cab. (See Remove Operator Cab, in Section 95, Group 00.)
4. **OOS Tractor:** Remove open operator's station. (See Remove Operator Station, in Section 90, Group 15.)
5. Remove MFWD drive shaft, if equipped. (See Remove, Inspect, and Install MFWD Drive Shaft, in Section 50, Group 05.)
6. Remove fuel tank (See Remove and Install Fuel Tank, Section 30, Group 05.)
7. Drain transmission oil.
8. **Perform the following steps on right-hand side of tractor:** Identify, label, and disconnect steering oil supply line (A) and oil cooler line (B) from mid frame (E).
9. Remove clamp (C) by removing cap screw (D) and remove oil lines (A and B)..

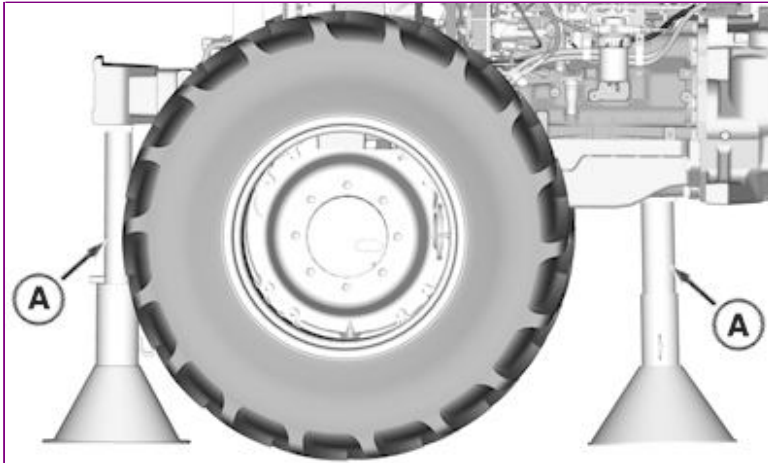

10. RXA0128540-UN: Support Stands

LEGEND:

A - Support Stands

Place support stands (A) on tractor for stability when separating.

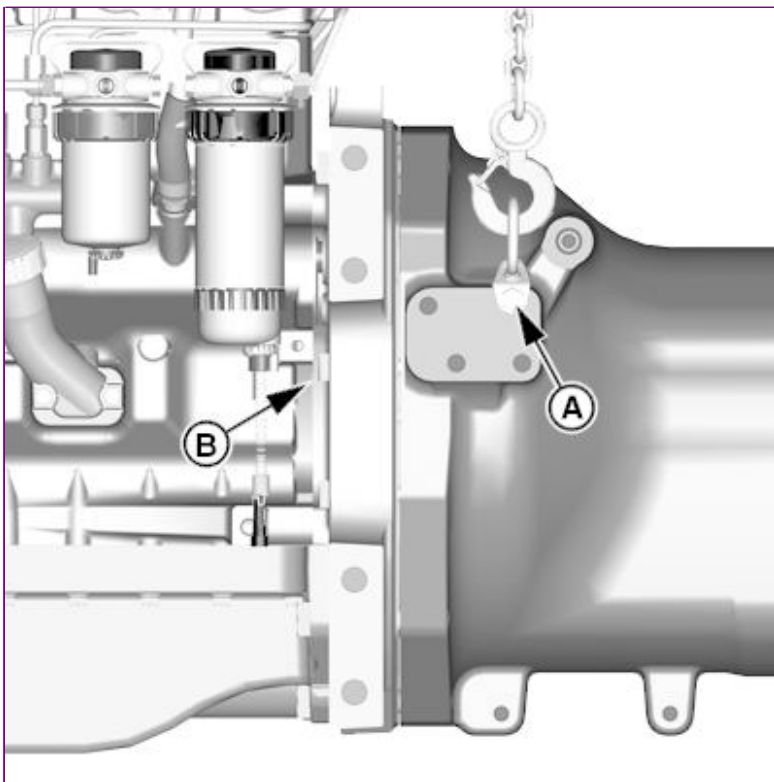

11. PY20653-UN: JDG19 Lifting Brackets

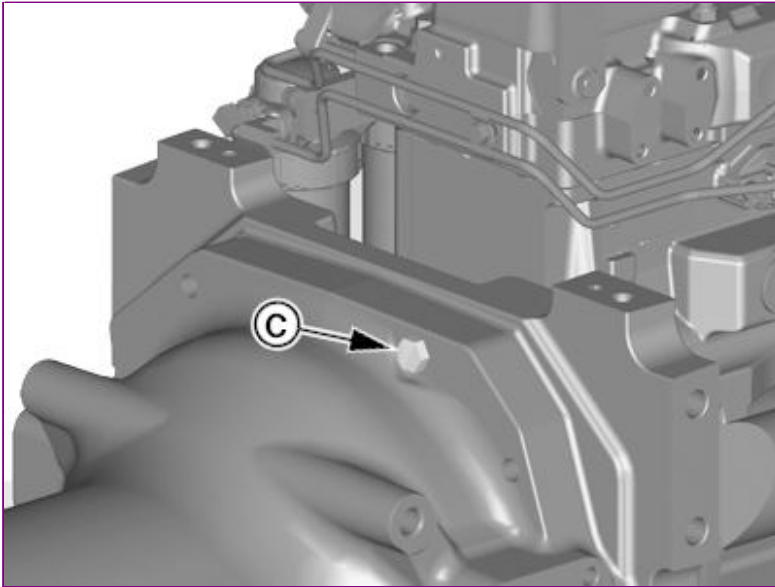

PY20657-UN: .

LEGEND:

- A - JDG19 Lifting Eyes
- B - Cap Screws (9 used)
- C - Cap Screw (1 used)

Install JDG19 Lifting Eyes (A) onto clutch housing on both sides of tractor.

12. Attach chains or lift straps to lifting eyes and an overhead lifting device.
13. Remove cap screws (B) attaching mid-frame to fly wheel housing.
14. Remove cap screw (C) from clutch housing side as shown.

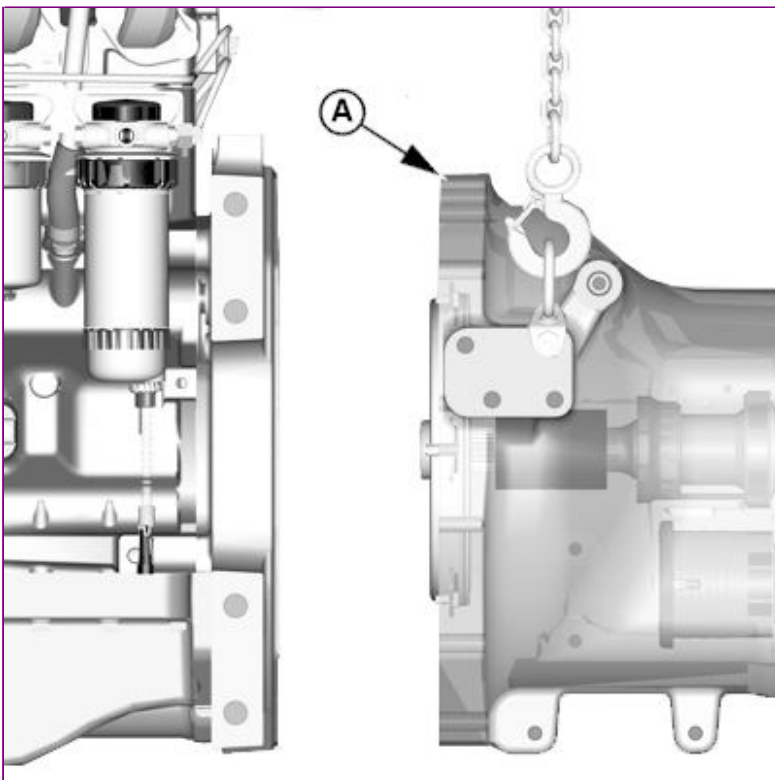

15.

PY20654-UN: Drive Train Assembly

LEGEND:

A - Drive Train Assembly

Carefully separate drive train assembly (A) from fly wheel housing.

16. Install in reverse order.

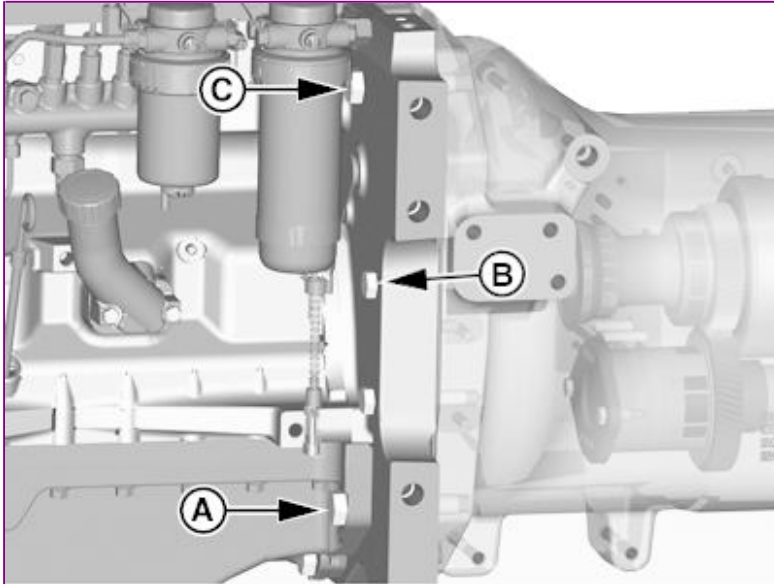

PY20655-UN: Cap Screws

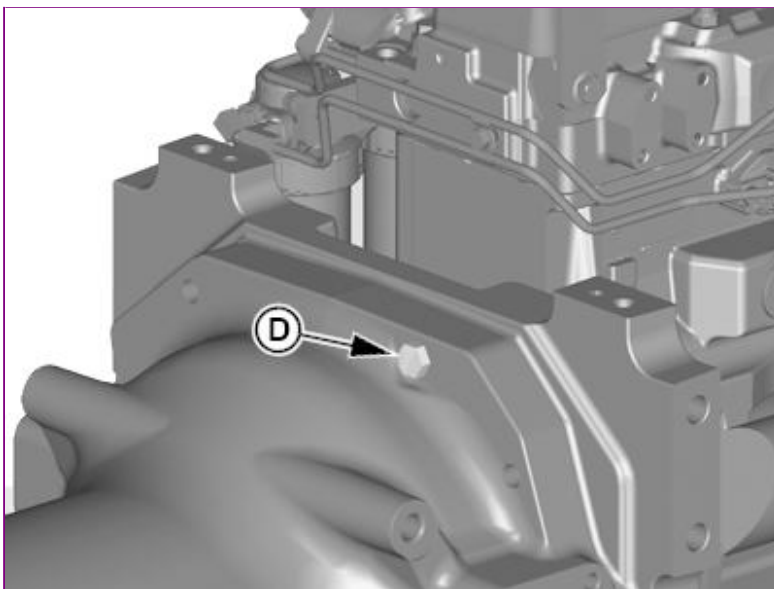

PY20656-UN: .

LEGEND:

A - M20 x 2.5 x 110 Cap Screw (4 used)

B - M16 x 2 x 90 Cap Screw (3 used)

C - M20 x 2.5 x 90 Cap Screw (2 used)

D - M16 x 2 x 70 Cap Screw (1 used)

Install cap screws (A, B, C and D) and tighten to specification.

Item	Measurement	Specification
Flywheel Housing-to-Clutch Housing Mounting Bolts	Torque	542 N·m (400 lb.-ft.)



Download the full PDF manual instantly.

Our customer service e-mail:

aservicemanualpdf@yahoo.com