

# 690 and 690-A Excavators

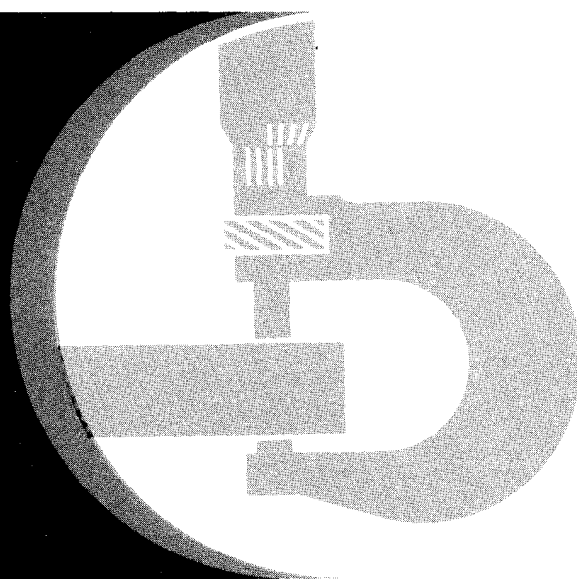

## TECHNICAL MANUAL

TM-1017

LITHO IN U.S.A.

# JD690 and JD690-A EXCAVATORS

## Technical Manual

TM-1017 (Jan-74)

### CONTENTS

SECTION 10 - GENERAL	SECTION 50 - POWER TRAIN
Group 5 - Specifications	Group 5 - Track and Swing Drive Assemblies
Group 10 - Predelivery, Delivery, and After-Sales Services	
Group 15 - Tune-Up and Adjustment	SECTION 60 - STEERING AND BRAKES
Group 20 - Lubrication	Group 5 - General Information
Group 25 - Separation	
SECTION 20 - ENGINE	SECTION 70 - HYDRAULIC SYSTEM
Group 5 - Diagnosis	Group 5 - General Information, Testing, and Diagnosis
Group 10 - Basic Engine	Group 10 - Main Hydraulic Pump
Group 15 - Engine Lubrication	Group 15 - Control Valve
Group 20 - Speed Control Linkage	Group 20 - Hydraulic Motors
Group 25 - Engine Cooling System	Group 25 - Rotary Manifold and Brake Valve
Group 30 - Specifications and Special Tools	Group 30 - Cylinders
	Group 35 - Flow Divider Valve
SECTION 30 - FUEL SYSTEM	Group 40 - Reservoir, Cooler and Filters
Group 5 - System Diagnosis	Group 45 - Specifications and Special Tools
Group 10 - Fuel Tank, Transfer Pump and Filters	
Group 15 - Air Intake System	SECTION 80 - MISCELLANEOUS COMPONENTS
Group 20 - Fuel Injection Pumps	Group 5 - Undercarriage
. . . . . - Fuel Injection Nozzles (refer to SM-2045)	Group 10 - Boom and Bucket
Group 25 - Specifications and Special Tools	Group 15 - Specifications and Special Tools
SECTION 40 - ELECTRICAL SYSTEM	SECTION - INDEX
Group 5 - Wiring Diagrams	
Group 10 - Charging Circuit	
Group 15 - Starting Circuit	
Group 20 - Gauges and Switches	
Group 25 - Specifications and Special Tools	

## INTRODUCTION

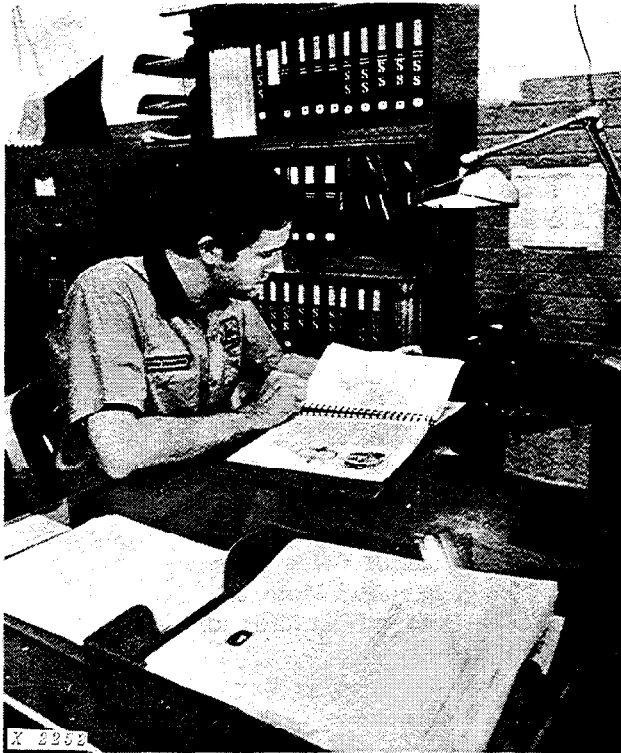

Use FOS Manuals for Reference



Use Technical Manuals for Actual Service

This technical manual is part of a twin concept of service:

- **FOS Manuals**—for reference
- **Technical Manuals**—for actual service

The two kinds of manuals work as a team to give you both the general background and technical details of shop service.

*Fundamentals of Service (FOS) Manuals* cover basic theory of operation, *fundamentals* of trouble shooting, *general* maintenance, and *basic* types of failures and their causes. FOS Manuals are for training new men and for reference by experienced men.

*Technical Manuals* are concise service guides for a specific machine. Technical Manuals are on-the-job guides containing only the vital information needed by a journeyman mechanic.



When a serviceman should refer to a FOS Manual for more information, a FOS symbol like the one at the left is used in the TM to identify the reference.

Some features of this technical manual:

- *Table of contents at front of manual*
- *Exploded views showing parts relationship*
- *Photos showing service techniques*
- *Specifications grouped for easy reference*

This technical manual was planned and written for you—a journeyman mechanic. Keep it in a permanent binder in the shop where it is handy. Refer to it whenever in doubt about correct service procedures or specifications.

Using the technical manual as a guide will reduce error and costly delay. It will also assure you the best in finished service work.



This safety alert symbol identifies important safety messages in this manual. When you see this symbol, be alert to the possibility of personal injury and carefully read the message that follows.

## Section 10 GENERAL

### CONTENTS OF THIS SECTION

	Page		Page
GROUP 5- SPECIFICATIONS		GROUP 20 - LUBRICATION	
Specifications . . . . .	5-1	Lubrication Chart . . . . .	20-1
		General Information . . . . .	20-1
GROUP 10 - PREDELIVERY, DELIVERY, AND AFTER-SALES SERVICES		GROUP 25 - SEPARATION	
Predelivery Service . . . . .	10-1	Removal and Installation	
Delivery Service . . . . .	10-2	Engine . . . . .	25-1
After-Sales Service . . . . .	10-3	Rear Bumper . . . . .	25-2
		Reservoir . . . . .	25-3
GROUP 15 - TUNE-UP AND ADJUSTMENT		Fuel Tank . . . . .	25-3
Preliminary Engine Testing . . . . .	15-1	Cab . . . . .	25-4
Engine Tune-Up . . . . .	15-1	Swing Motor . . . . .	25-4
Excavator Adjustments . . . . .	15-3	Track Motors . . . . .	25-5
Undercarriage Adjustments . . . . .	15-3	Undercarriage . . . . .	25-6
Standard Torque Chart . . . . .	15-3	Specifications . . . . .	25-7

## Group 5 SPECIFICATIONS

### ENGINE

Type . . . 6-cylinder, in-line, valve-in-head,  
diesel, turbocharged.  
Bore and Stroke . . . . . 4-1/4 in. x 4-3/4 in.  
Displacement . . . . . 404 cu. in.  
Compression ratio . . . . . 16.5 to 1  
Firing order . . . . . 1-5-3-6-2-4  
Valve clearances . . . . . Intake-0.018 in.  
Exhaust - 0.022 in.  
Injection pump timing . . . . . TDC  
Engine speeds:  
Slow idle . . . . . 800 rpm  
Fast idle . . . . . 2650 rpm  
Governed Speed Range . . . . . 800-2650 rpm

LUBRICATION SYSTEM . . . Fully pressurized  
with full-flow micronic  
oil filter, oil  
cooler, and bypass  
valves for filter and cooler.

### FUEL SYSTEM

Type . . . . . Direct injection.  
Filters . . . . . Two-stage with replaceable  
impregnated paper elements.  
Injection pump . . . . . Inlet metering,  
distributing type.  
Air cleaner . . . . . Dry type.

### COOLING SYSTEM

Type . . . Pressurized with centrifugal pump.  
Temperature control . . . . . Heavy duty  
thermostat.

### CAPACITIES (U.S. Standard Measures)

Fuel tank . . . . . 60 gals.  
Cooling system . . . . . 45 qts.  
Crankcase . . . . . 15 qts.  
(modified dipstick) . . . . . 20 qts.  
(later units) . . . . . 17 qts.  
Hydraulic system . . . . . 80 gals.  
Swing motor gearbox . . . . . 7-1/2 qts.  
Propel motor gearbox (two each) 4-1/2 qts.  
Hydraulic oil reservoir to oil  
level window . . . . . 40 gals.

**HYDRAULIC SYSTEM**

Type . . . . . Open center.  
Pump . . . . . Tandem.

Alternator . . . 12-volt, 55-amp (early units),  
35-amp (later units); with in-  
tegral transistorized regulator.

**ELECTRICAL SYSTEM**

Type . . . . . 12-volt, negative grounded.  
Batteries . . . . . Two, 6-volt, 75-plate  
360 minute reserve capacity,  
3 EH type, connected in series.

**MAXIMUM GROUND SPEED . . . . . 1.2 mph.**

**WEIGHT . . . . . 36,105 lbs. (less bucket).**

**DIMENSIONS**

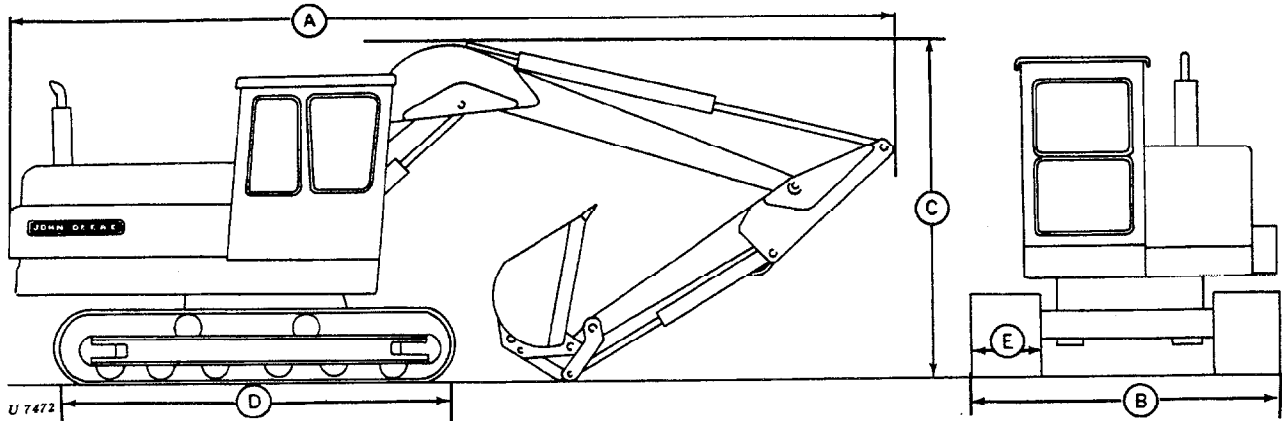

Fig. 1-Excavator Overall Dimensions

A. Length . . . . .	29 ft. 6 in.
B. Width . . . . .	7 ft. 11 in.
C. Height (to top of boom) . . . . .	10 ft. 10 in.
D. Track length . . . . .	12 ft. 6 in.
E. Track shoe width . . . . .	24 in.

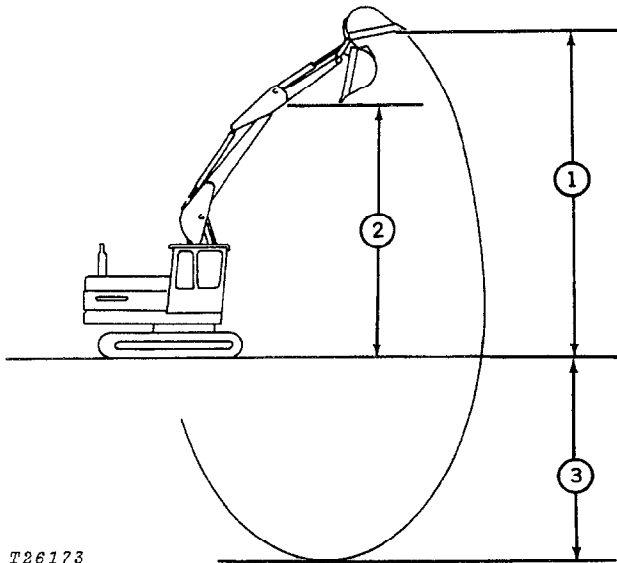

Fig. 2-Excavator Operating Dimensions

1. Maximum reach . . . . .	30 ft.
2. Maximum dumping height . . . . .	15 ft.
3. Maximum digging depth . . . . .	21 ft.
Digging force (24 in. bucket) . . . . .	23,000 lbs.
Swing, 360 degree continuous . . . . .	7 rpm
Gradability . . . . .	50 per cent

*Specifications and design are subject to change without notice. Wherever applicable, specifications are in accordance with SAE, PCSA and I.E.M.C. Standards.*

## Group 10 PREDELIVERY, DELIVERY, AND AFTER-SALES SERVICES

### PREDELIVERY SERVICE

Every new John Deere machine leaves the factory so that it can be delivered to the customer after a minimum of servicing.

Shipping factors, however, in addition to extra finishing touches needed for customer satisfaction, necessitate proper predelivery service by the dealer.

A tag pointing out the factory-recommended procedure for predelivery service is attached to every new machine before it leaves the factory.

After completing the factory-recommended checks and services listed on the predelivery tag, remove and file the tag with the job shop order. The tag will then certify that the unit has received the proper predelivery service.

*NOTE: Remove plug from exhaust outlet and install muffler before unloading machine. Cover exhaust whenever transporting the machine.*

### TEMPORARY MACHINE STORAGE\*

Service	Specification	Reference
Check radiator for coolant loss and anti-freeze protection.	Fill to level with baffle in neck of radiator.	.....
Relieve hydraulic pressure.	Stop engine, lower boom and operate control handles.	Operator's Manual
Check and charge batteries.	Specific gravity is 1.240 to 1.260 (full charge).	Section 40, Group 10
Cover machine for protection and cleanliness.	.....	.....

*\*See Operator's Manual for extended storage instructions.*

### BEFORE DELIVERING MACHINE

#### ELECTRICAL SYSTEM

Check battery terminals to be sure they are tight. .... Operator's Manual

Punch date code on battery tag. ....

Inspect electrolyte and charge batteries, if required. Bottom of filler neck. Operator's Manual

Check alternator and fan belt tension. .... Operator's Manual

#### COOLING SYSTEM

Inspect radiator for coolant loss. Fill to level with baffle in neck of radiator. ....

Check antifreeze protection. ....

#### TRACKS

Check track adjustment. 1-in. sag. Operator's Manual

Check chain adjustment. 1/2-in. sag. Operator's Manual

Service	Specification	Reference
<b>LUBRICATION</b>		
Check crankcase oil level.	To upper marks on dipstick.	Operator's Manual
Check hydraulic system oil level.	.....	Operator's Manual
Check swing and track gearbox oil levels.	.....	Operator's Manual
Lubricate grease fittings.	John Deere Multi-Purpose Lubricant or an equivalent.	Operator's Manual
<b>ENGINE</b>		
Check air cleaner.	.....	Operator's Manual
Fill fuel tank and start engine.	.....	Operator's Manual
Check engine idle speeds.	.....	Section 20, Group 15
<b>OPERATION</b>		
Check hydraulic system operation.	.....	Section 70, Group 5
Check flow divider valve operation.	.....	Section 70, Group 35
Check pump disconnect.	.....	Operator's Manual
Check gauge and indicator lamp operation.	.....	Operator's Manual
Check swing and track motor operation.	.....	Operator's Manual
Check swing brake operation.	.....	Operator's Manual
Check seat operation.	.....	Operator's Manual
<b>GENERAL</b>		
Tighten cap screws and nuts.	.....	.....
Clean machine and touch up paint.	.....	.....
Check air cleaner and attaching connections for potential leaks.	.....	.....

**DELIVERY SERVICE**

A thorough discussion of the operation and service of a new machine at the time of delivery helps to assure complete customer satisfaction. Proper delivery should be an important phase of a dealer's program. One section of the John Deere Delivery Receipt emphasizes the importance of proper delivery service.

Complaints may arise if the owner is not shown how to operate and service his new machine correctly. Devote enough time, at your customer's convenience, to introduce him to his new machine. Explain fully how to operate and service it.

Using the operator's manual as a guide, be sure that the owner thoroughly understands the following points:

1. Operation and use of controls and instruments.
2. Operation of the engine.
3. Importance of the break-in period.
4. Operation and functions of the hydraulic system.
5. Importance of safety.
6. Importance of lubrication and periodic services.

## AFTER-SALES SERVICE

The purchaser of a new John Deere machine is entitled to a free inspection at some mutually agreeable time within the warranty period after the equipment has been "run in." The terms of this after-sales inspection are outlined on the back of the customer's John Deere Delivery Receipt.

The purpose of this inspection is to ensure that the customer is receiving satisfactory performance from his machine. At the same time, the inspection should reveal whether or not the machine is being operated, lubricated, and serviced properly.

If the recommended after-sales service inspection is followed, the dealer may eliminate minor irregularities which could develop into major service problems at a later date. This will promote strong dealer-customer relations and give the dealer an opportunity to answer questions that may have arisen during initial operation.

During the inspection service, the dealer has the opportunity to recommend additional new equipment and accessories.

### INSPECTION PROCEDURES

Service	Specification	Reference
Check radiator coolant level.	Fill to level with baffle in neck of radiator.	.....
Clean external surface of radiator core.	.....	.....
Check hoses and connections for leaks.	.....	.....
<b>FUEL SYSTEM</b>		
Remove water and foreign matter from fuel pump and filter sediment bowls. Replace filters, if necessary.	.....	Operator's Manual
Tighten loose connections and check entire fuel system for leaks.	.....	.....
Check air cleaner elements and clean, if necessary.	.....	Operator's Manual
<b>ELECTRICAL SYSTEM</b>		
Check specific gravity and electrolyte level of batteries.	Specific gravity is 1.240 to 1.260 (full charge)	Operator's Manual
Check fan belt tension.	3/4-inch deflection with 20 lbs. force; 100 to 110 lb. strand tension if belt gauge is used.	Operator's Manual
Start engine and check action of starter and indicator lamps.	.....	Operator's Manual
<b>ENGINE</b>		
Check crankcase oil level.	To upper marks on dipstick.	Operator's Manual



Service	Specification	Reference
<b>ENGINE—Continued</b>		
Check valve clearances.	Intake - 0.018 in. Exhaust - 0.022 in.	Section 20, Group 5
Check engine speed under load.	.....	Section 20, Group 15
<b>HYDRAULIC SYSTEM</b>		
Check pump disconnect operation.	.....	Operator's Manual
Check hydraulic cylinder operation, fittings, and hose positions.	.....	Operator's Manual
Check oil level of swing and track motor gearboxes.	.....	Operator's Manual
<b>TRACKS</b>		
Check drive chain adjustment.	.....	Section 80, Group 5
Check track adjustment.	.....	Section 80, Group 5

## Group 15

# TUNE-UP AND ADJUSTMENT

### GENERAL INFORMATION

The following preliminary tests can determine if an engine is in such a condition that performance can be restored by tune-up.

#### PRELIMINARY ENGINE TESTING

Operation	Specification	Reference
Check radiator for air bubbles and indication of oil.	.....	Section 20, Group 20
Check cylinder compression.	400 psi minimum (25 psi maximum variation between cylinders)	FOS Manual - ENGINES
Test vacuum (air cleaner).	8 to 25 in. of water	FOS Manual - ENGINES

#### ENGINE TUNE-UP

##### AIR INTAKE SYSTEM

Check air cleaner and service as necessary.	8 in. of water clean - 25 in. or more water maximum (at 2200 rpm)	Section 30, Group 15
Restriction indicator light.	24 to 26 in. of water	Section 30, Group 15

##### COOLING SYSTEM

Clean grille screen, radiator core, and oil cooler core.	.....	.....
Clean and flush system; check thermostat.	.....	FOS Manual - ENGINES
Check pressure cap.	.....	FOS Manual - ENGINES

##### CYLINDER HEAD AND VALVES

Tighten cap screws.	130 ft-lbs	Section 20, Group 5
Set engine valve tappet clearances.	Intake - 0.018 in. Exhaust - 0.022 in.	Section 20, Group 5

ENGINE TUNE-UP—Continued

Operation	Specification	Reference
<b>CHARGING SYSTEM</b>		
Check battery specific gravity.	1.240 to 1.260	Section 40, Group 10
Check battery water consumption and electrolyte level.	.....	FOS Manual - ELECTRICAL SYSTEMS
Clean battery, cables, and box.	.....	.....
Check alternator belt tension.	.....	Section 20, Group 20
Check fan belt tension.	.....	Section 20, Group 20
Check alternator.	.....	Section 40, Group 10
<b>FUEL SYSTEM</b>		
Check fuel tank for water.	.....	.....
Check fuel pump pressure.	.....	Section 30, Group 10
Clean sediment bowls and change filter.	.....	Section 30, Group 10
Check injection nozzles.	.....	SM-2045 "Testing and Servicing Fuel Injection Pumps and Nozzles"
Check injection pump advance.	.....	Section 30, Group 20
Adjust throttle linkage.	.....	Section 20, Group 15
Check engine oil pressure.	40 to 50 psi (1900 rpm) (normal operating temperature)	Section 20, Group 10

**EXCAVATOR ADJUSTMENTS**

Operation	Specification	Reference
HYDRAULIC SYSTEM CYCLE TIMES	.....	Section 70, Group 5
UNDERCARRIAGE ADJUST- MENTS		
Check track tension.	.....	Section 80, Group 5
Check chain tension.	.....	Section 80, Group 5
TIGHTEN ACCESSIBLE BOLTS AND CAP SCREWS.	See torque chart below.	.....

**STANDARD TORQUE CHART**



*The torques shown in the chart at right do not apply for self-locking nut or cap screw or when bearing on aluminum or other soft metal.*

*The types of bolts and cap screws are identified by head markings as follows:*

*Plain Head : regular machine bolts and cap screws*

*3-Dash Head: tempered steel high-strength bolts and cap screws.*

*6-Dash Head: tempered steel extra high-strength bolts and cap screws.*

RECOMMENDED TORQUE IN FT.-LBS COARSE AND FINE THREADS			
	B	D	F
			
Bolt Diameter	Plain Head	Three Dashes	Six Dashes
1/4	Not used	10	14
5/16	Not used	20	30
3/8	Not used	35	50
7/16	35	55	80
1/2	55	85	120
9/16	75	130	175
5/8	105	170	240
3/4	185	300	425
7/8	160	445	685
1	250	670	1030
1-1/8	330	910	1460
1-1/4	480	1250	2060

## Group 20 LUBRICATION

### GENERAL INFORMATION

Detailed and illustrated lubrication instructions are in the operator's manual furnished with your customer's machine. Remind him to follow those instructions carefully.

When servicing the excavator, use the following chart to determine capacities and types of lubricants for each of the various components and systems. A definition of the various lubricants follows the chart.

Component	Capacity	Type of Lubricant
Engine crankcase	16 U.S. quarts 20 qts. (modified dipstick) 15 qts. (690-A) 17 qts. (690-A Engine Serial No. 359844- )	See "Engine Lubricating Oils" on page 20-2.
Hydraulic reservoir	To sight glass	SAE 10W (SC/CC) (MIL-L-2104B)
Return filters (hydraulic oil)	.....	.....
Swing and track gearboxes	7-1/2 quarts - swing 4-1/2 quarts - propel (2)	Shell Omala 72, Mobil Mobilube GX-90 or an equivalent.
Swinging gear*	6-1/2 to 7-1/2 quarts	Texaco "1X" Compound, Shell Cardium EPC Compound or an equivalent.
Swing bearing grease fittings	.....	Shell Alvania "EP-2" or an equivalent.
Grease fittings	.....	John Deere Multi-Purpose Lubricant or an equivalent.
Reservoir and suction filter	.....	.....
Starter	Saturate wicks (3)  Lubricate armature shaft splines during assembly	Engine crankcase oil (SAE 10W)  Engine crankcase oil (SAE 10W)

*\*Below 0°F, add 1-1/2 qt. No. 1 diesel fuel to crater compound. Swing slowly 10 minutes to mix. Above 40°, drain and refill with undiluted Cardium Compound EPC or an equivalent.*

## LUBRICANTS

Effective use of lubricating oils and greases is perhaps the most important step towards low upkeep cost, long excavator life, and satisfactory service. Use only lubricants specified in this section; apply them at intervals and according to the instructions in the lubrication and periodic service section.

### ENGINE LUBRICATING OILS



We recommend John Deere Torq-Gard or Torq-Gard Supreme engine oil for use in the engine crankcase. This oil is compounded specifically for use in John Deere engines, and provides superior lubrication under all conditions. NEVER PUT ADDITIVES IN THE CRANKCASE. Torq-Gard oil is formulated to provide all the protection your engine needs. Additives could reduce this protection rather than help it.

If oil other than Torq-Gard or Torq-Gard Supreme is used, it must conform to the following specifications.

#### SINGLE VISCOSITY OILS

API Service CD/SD  
MIL-L-2104C  
Series 3

#### MULTI-VISCOSITY OILS

API Service CC/SD  
MIL-L-46152

Depending on the expected prevailing temperature for the fill period, use oil of viscosity as shown in the following chart.

Air Temperature	John Deere Torq-Gard Oil	Other Oils	
		Single Viscosity	Multi-Viscosity Oil
Above 32° F.	SAE 30	SAE 30	Not recommended.
-10° F. to 32° F.*	SAE 10W-20	SAE 10W	SAE 10W-30
Below -10° F.	SAE 5W-20	SAE 5W	SAE 5W-30

*\*SAE 5W-20 oil may also be used to insure optimum lubrication at starting, particularly when engine is subjected to -10° F. or lower temperatures for several hours.*

*Some increase in oil consumption may be expected when SAE 5W-20 or SAE 5W oils are used. Check oil level more frequently.*

### HYDRAULIC OIL

Use only SAE 10W oil (API designation SC/CC and military specification Mil-L-2104B). This oil is suitable for all weather conditions.

### GREASES

Use John Deere Multi-Purpose Lubricant or an equivalent multipurpose-type grease for all grease fittings unless otherwise indicated. Application of grease as instructed in the lubrication chart will provide proper lubrication and will prevent contamination of bearings.

### STORING LUBRICANTS

This excavator can operate efficiently only if clean lubricants are used. Use clean containers to handle all lubricants. Store them in an area protected from dust, moisture, and other contamination.

## Group 25 SEPARATION

### REMOVING AND INSTALLING ENGINE

#### REMOVAL

Operate controls to release hydraulic pressure from hydraulic system.

Disconnect battery ground strap.

Swing access fenders away from engine.

Hook a hoist through the air cleaner access door and remove hood assembly.

Lift grille housing at radiator filler cap access door.

Disconnect fuel lines, electrical harness, oil pressure hose, starting aid tube, and throttle linkage.

Disconnect main hydraulic pump and hydraulic oil cooler lines.

Support fuel tanks and disconnect fuel tank-to-engine brackets.

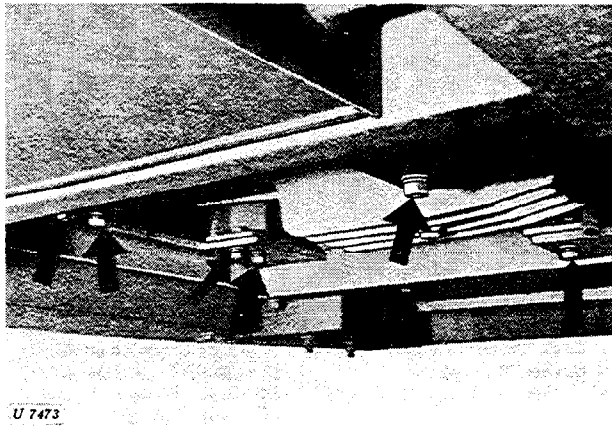
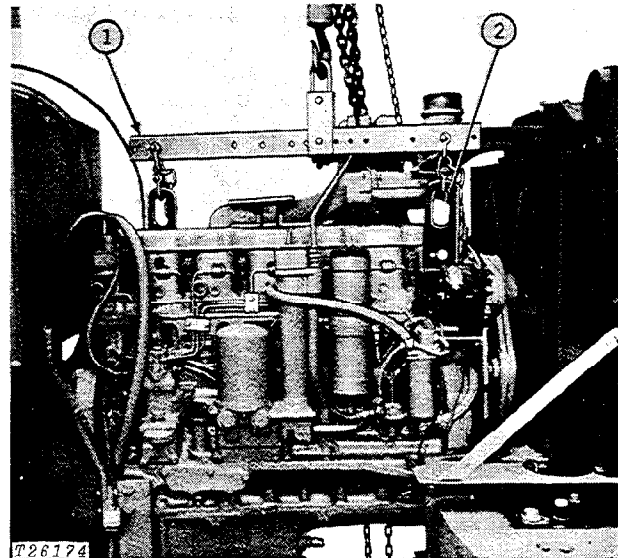

Fig. 1-Engine Attaching Cap Screws  
(Early Unit Shown)

Remove cap screws (Fig. 1) securing engine to frame.



1 - Engine Sling (JDG-1)      2 - Lift Eye (JD244)

Fig. 2-Removing Engine

Remove engine (Fig. 2) using hoist and lifting eyes. See "SPECIAL TOOLS, page 10-25-8."

#### INSTALLATION

Place engine mounts on engine and tighten bolts finger tight.

Set engine on main frame. Shim any engine mounts that do not sit flat on engine mounting plates in main frame as required to remove misalignment. Tighten mounting plate-to-main frame bolts (400 ft-lbs). Tighten engine-to-engine mounting bracket bolts last.

Install and connect all parts removed during engine removal.

Start engine and check fuel lines, hydraulic lines, and radiator hoses for leaks.

### REMOVING AND INSTALLING REAR BUMPER

#### REMOVAL

Operate controls to release hydraulic pressure from hydraulic system.

Disconnect battery ground strap.

Drain radiator and remove grille housing and radiators.

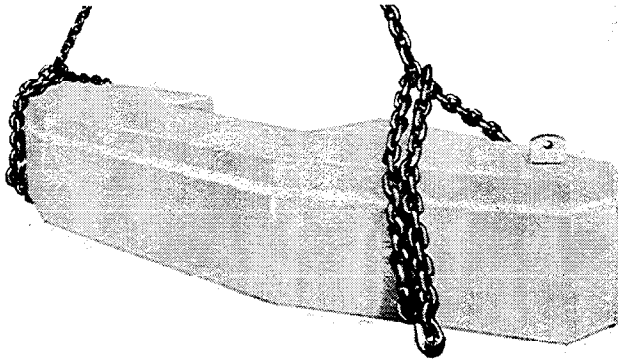

T 19671

Fig. 3—Removing Rear Bumper

Attach chain hoist to either the one piece or three piece bumper as shown and remove unit by pulling bumper rearward.

*NOTE: Three piece bumper should be removed as an assembly.*

**CAUTION:** Use care that chain does not slip out from under bumper. Be sure hoist is large enough to lift assembled bumper. See specifications for weight on rear bumper.

The side and center counterweights (Fig. 4) used with the one piece bumper may be removed from rear bumper by placing floor jack under counterweights, removing cap screws and slowly lowering weight from bumper.

**CAUTION:** Use care that counterweights do not slip off floor jack. See Specifications for weights of counterweights.

#### INSTALLATION

Install rear bumper assembly using the same CAUTIONS that were outlined during removal.

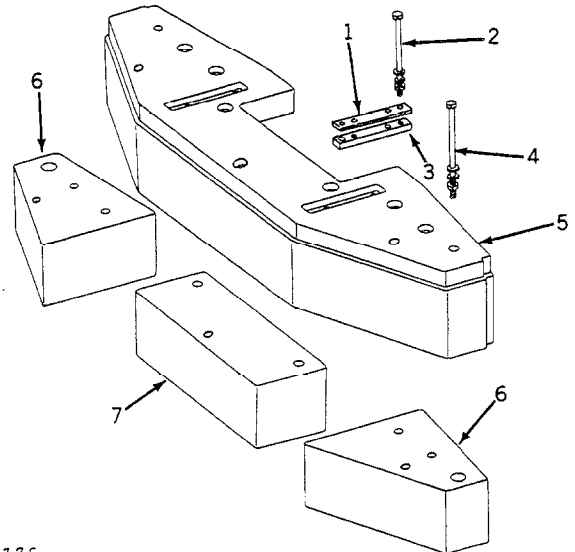

T26176

- 1 - Bumper Shim (2 used)
- 2 - Hex. Bolt (4 used)
- 3 - Anchor Block (4 used)
- 4 - Hex. Bolt (9 used)

- 5 - Rear Bumper
- 6 - Side Counterweight (2 used)
- 7 - Center Counterweight

Fig. 4—Rear Bumper Assembly  
(Serial No. 001711)

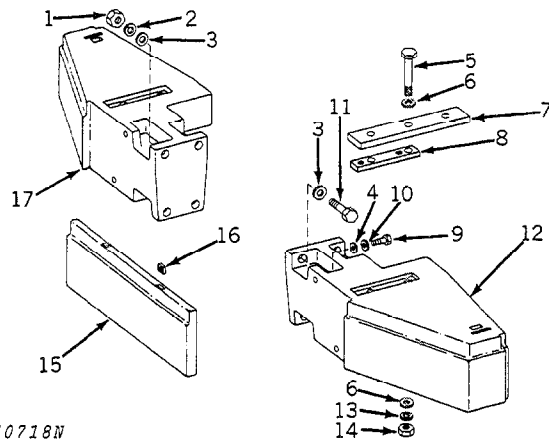

T30718W

- 1 - Nut (4 used)
- 2 - Lock Washer (4 used)
- 3 - Washer (8 used)
- 4 - Washer (4 used)
- 5 - Bolt (9 used)
- 6 - Special Washer (18 used)
- 7 - Bumper Shim (2 used)
- 8 - Anchor Block (4 used)
- 9 - Cap Screw (4 used)

- 10 - Lock Washer (4 used)
- 11 - Cap Screw (4 used)
- 12 - Right Split Bumper
- 13 - Lock Washer (9 used)
- 14 - Nut (9 used)
- 15 - Center Bumper
- 16 - Nut (4 used)
- 17 - Left Split Bumper

Fig. 5—Rear Bumper Assembly  
(Serial No. 001712)





**Download the full PDF manual instantly.**

**Our customer service e-mail:**

**[aservicemanualpdf@yahoo.com](mailto:aservicemanualpdf@yahoo.com)**