

Document Title: Frame, description	Function Group: 711	Information Type: Service Information	Date: 2015/9/10
Profile: COS, SD70D, SD77F [GB]			

Frame, description

The machine consists of a front and rear frame which are connected by a vertical articulation pin and a horizontal articulation pin. The front frame consists of the drum assembly, while the rear frame consists of the operator's platform, rear axle and wheels, engine, hydraulic oil tank and fuel tank.

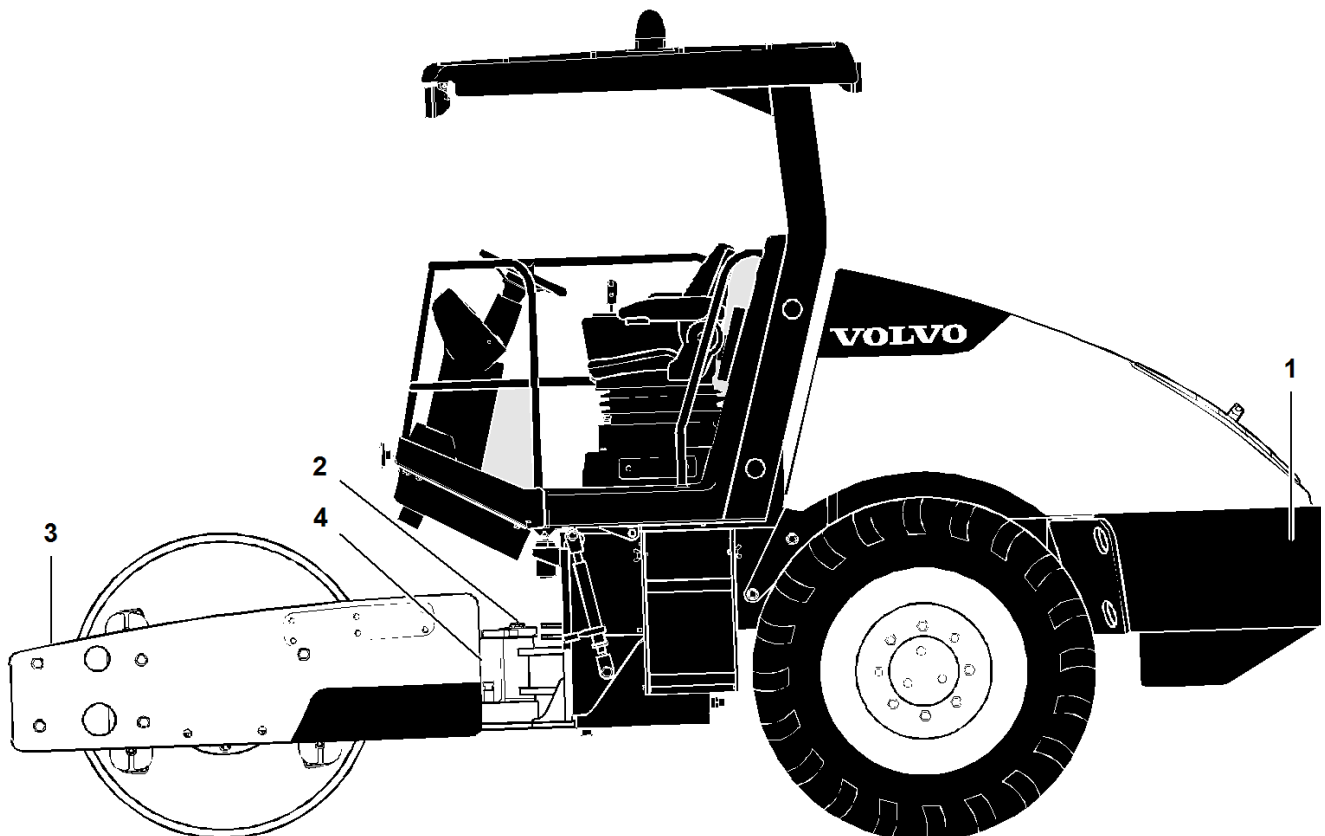

V1070711

Figure 1
Frame and components

1. Rear frame
2. Vertical articulation pin
3. Front frame
4. Horizontal articulation pin

Document Title: Wheel, removing and fitting one	Function Group: 771	Information Type: Service Information	Date: 2015/9/10
Profile: COS, SD70D [GB]			

Wheel, removing and fitting one

Op nbr 771-001

[11668010 Wheel forklift](#)

NOTE!

Read the "Safety Section" before starting the procedure. Refer to [191 Some simple rules regarding tyre handling](#).

Removing the wheel

1. Place the machine in service position. Refer to [191 Service position 1](#).
2. Secure the machine with a stand under the axle of the wheel to be removed. Make sure it is positioned correctly and has safe ground support.



WARNING

Never work under/on machines without using recommended support equipment.

NOTE!

Before lifting the machine read [191 Safety when lifting and supporting complete machine](#).

3. Use a wheel forklift and secure the wheel.

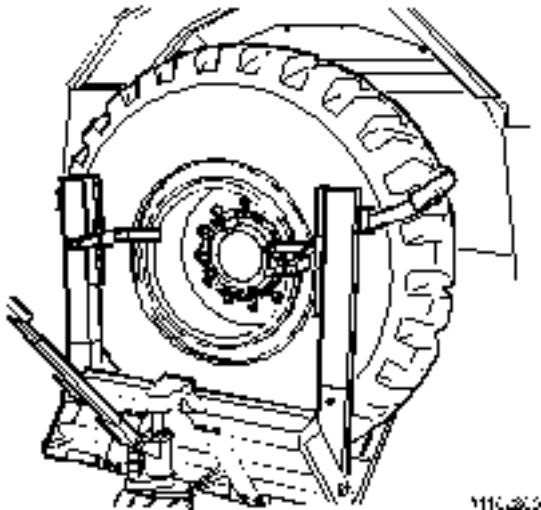

Figure 1
Wheel forklift

4. Remove the wheel nuts and wheel from the machine.



WARNING

Risk of personal injury. Very heavy object.

Wheel weight (including fluid): 300kg (661 lbs)

NOTE!

When mounting a tyre the qualified person should:

- Ensure the rim is clean and rust free.
- The rim must be free of any damage that could prevent proper seating along the bead, or cause improper tyre rotation and premature wear, or affect handling of the machine.
- Generously lubricate both tyre and rim.



Explosion hazard.

- **Never inflate the tyre to over 2.4 bar (35 psi) to seat beads. Excessive inflation pressure when seating beads may cause the tyre and rim assembly to explode causing severe injury or death.**
- Check to ensure normal operating pressure is not above 1.1 bar (16 psi).

NOTE!

Placing water in tyres is an economical means of adding weight to the wheels of the machine. The addition of calcium chloride to the water is recommended to prevent the water from freezing. If a tyre with ballast is replaced the replacement tyre must also contain an equal amount of ballast.

Contact your Manufacturer's Authorized Dealer or Distributor for more information on ballasted tyres.

Reinstalling the wheel

5. Before reinstalling the wheel to the axle hub, clean the mounting face of the axle and wheel with a wire brush.
6. Reinstall the wheel with the wheel forklift.
Wheel weight (including fluid): 614 kg (1350 lb)
7. Reinstall the wheel nuts. Torque tighten the nuts diagonally to specification. Refer to [030 Wheel tightening torque](#).



V1066919

Figure 2

Wheel nuts, torque tighten

8. Lower the machine and remove the lifting device and support stands.
9. Check the pressure in the tyre. Refer to [173 Tyres, checking air pressure](#).

NOTE!

Tyre valve stem must be in the 12 o'clock position.

10. Place the machine back in service.

Document Title: Wheel, removing and fitting one	Function Group: 771	Information Type: Service Information	Date: 2015/9/10
Profile: COS, SD70D [GB]			

[Go back to Index Page](#)

Wheel, removing and fitting one

Op nbr 771-001

[11668010 Wheel forklift](#)

NOTE!

Read the "Safety Section" before starting the procedure. Refer to [191 Some simple rules regarding tyre handling](#).

Removing the wheel

1. Place the machine in service position. Refer to [191 Service position 1](#).
2. Secure the machine with a stand under the axle of the wheel to be removed. Make sure it is positioned correctly and has safe ground support.



Never work under/on machines without using recommended support equipment.

NOTE!

Before lifting the machine read [191 Safety when lifting and supporting complete machine](#).

3. Use a wheel forklift and secure the wheel.

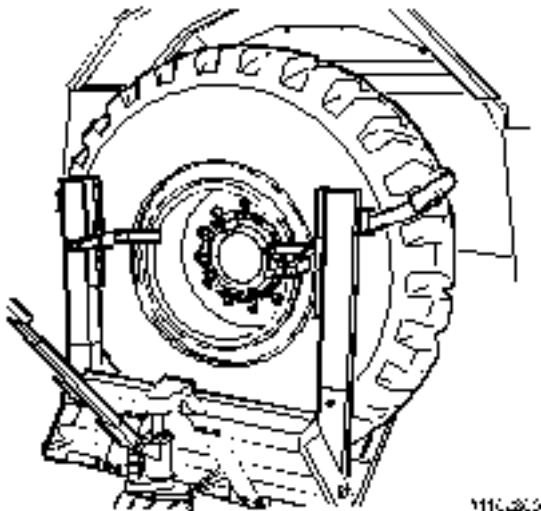

Figure 1
Wheel forklift

4. Remove the wheel nuts and wheel from the machine.



Risk of personal injury. Very heavy object.

Wheel weight (including fluid): 300kg (661 lbs)

NOTE!

When mounting a tyre the qualified person should:

- Ensure the rim is clean and rust free.
- The rim must be free of any damage that could prevent proper seating along the bead, or cause improper tyre rotation and premature wear, or affect handling of the machine.
- Generously lubricate both tyre and rim.



Explosion hazard.

- **Never inflate the tyre to over 2.4 bar (35 psi) to seat beads. Excessive inflation pressure when seating beads may cause the tyre and rim assembly to explode causing severe injury or death.**
- Check to ensure normal operating pressure is not above 1.1 bar (16 psi).

NOTE!

Placing water in tyres is an economical means of adding weight to the wheels of the machine. The addition of calcium chloride to the water is recommended to prevent the water from freezing. If a tyre with ballast is replaced the replacement tyre must also contain an equal amount of ballast.

Contact your Manufacturer's Authorized Dealer or Distributor for more information on ballasted tyres.

Reinstalling the wheel

5. Before reinstalling the wheel to the axle hub, clean the mounting face of the axle and wheel with a wire brush.

6. Reinstall the wheel with the wheel forklift.

Wheel weight (including fluid): 614 kg (1350 lb)

7. Reinstall the wheel nuts. Torque tighten the nuts diagonally to specification. Refer to [030 Wheel tightening torque](#).



V1066919

Figure 2

Wheel nuts, torque tighten

8. Lower the machine and remove the lifting device and support stands.

9. Check the pressure in the tyre. Refer to [173 Tyres, checking air pressure](#).

NOTE!

Tyre valve stem must be in the 12 o'clock position.

10. Place the machine back in service.

Document Title: Wheel, removing and fitting one	Function Group: 771	Information Type: Service Information	Date: 2015/9/10
Profile: COS, SD70D [GB]			

[Go back to Index Page](#)

Wheel, removing and fitting one

Op nbr 771-001

[11668010 Wheel forklift](#)

NOTE!

Read the "Safety Section" before starting the procedure. Refer to [191 Some simple rules regarding tyre handling](#).

Removing the wheel

1. Place the machine in service position. Refer to [191 Service position 1](#).
2. Secure the machine with a stand under the axle of the wheel to be removed. Make sure it is positioned correctly and has safe ground support.



Never work under/on machines without using recommended support equipment.

NOTE!

Before lifting the machine read [191 Safety when lifting and supporting complete machine](#).

3. Use a wheel forklift and secure the wheel.

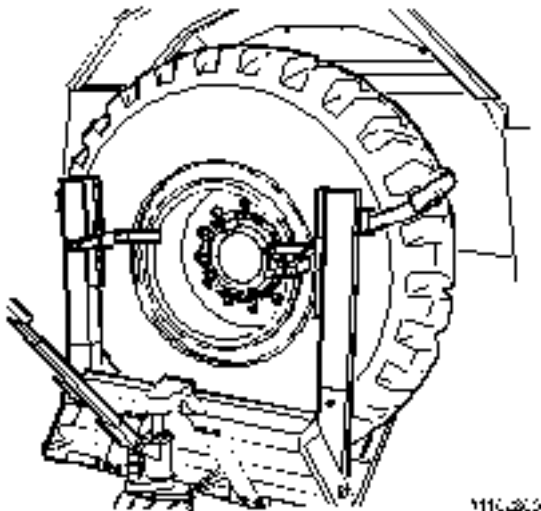

Figure 1
Wheel forklift

4. Remove the wheel nuts and wheel from the machine.



Risk of personal injury. Very heavy object.

Wheel weight (including fluid): 300kg (661 lbs)

NOTE!

When mounting a tyre the qualified person should:

- Ensure the rim is clean and rust free.
- The rim must be free of any damage that could prevent proper seating along the bead, or cause improper tyre rotation and premature wear, or affect handling of the machine.
- Generously lubricate both tyre and rim.



Explosion hazard.

- **Never inflate the tyre to over 2.4 bar (35 psi) to seat beads. Excessive inflation pressure when seating beads may cause the tyre and rim assembly to explode causing severe injury or death.**
- Check to ensure normal operating pressure is not above 1.1 bar (16 psi).

NOTE!

Placing water in tyres is an economical means of adding weight to the wheels of the machine. The addition of calcium chloride to the water is recommended to prevent the water from freezing. If a tyre with ballast is replaced the replacement tyre must also contain an equal amount of ballast.

Contact your Manufacturer's Authorized Dealer or Distributor for more information on ballasted tyres.

Reinstalling the wheel

5. Before reinstalling the wheel to the axle hub, clean the mounting face of the axle and wheel with a wire brush.

6. Reinstall the wheel with the wheel forklift.

Wheel weight (including fluid): 614 kg (1350 lb)

7. Reinstall the wheel nuts. Torque tighten the nuts diagonally to specification. Refer to [030 Wheel tightening torque](#).



V1066919

Figure 2

Wheel nuts, torque tighten

8. Lower the machine and remove the lifting device and support stands.

9. Check the pressure in the tyre. Refer to [173 Tyres, checking air pressure](#).

NOTE!

Tyre valve stem must be in the 12 o'clock position.

10. Place the machine back in service.

Document Title: Drum, description	Function Group: 777	Information Type: Service Information	Date: 2015/9/10
Profile: COS, SD70D [GB]			

Drum, description

The compactor is equipped with either a smooth drum or a pad foot drum. Smooth drums are used for granular (non cohesive) soils and pad foot drums for clay (cohesive) soils.

The smooth drum is scraped clean by means of scraper blades which are held close to the drum at the front and back (optional). The pad foot drum is cleaned by means of adjustable and replaceable steel teeth, bolted to the drum frame. These pass between the moving pads and dislodge any material stuck to the drum.

The drum contains an eccentric weight that can be made to rotate at one of two speeds. This provides the vibrating motion that improves the compaction ability of the compactor. A bolt on conversion kit is also available to convert a smooth drum to a pad foot drum.

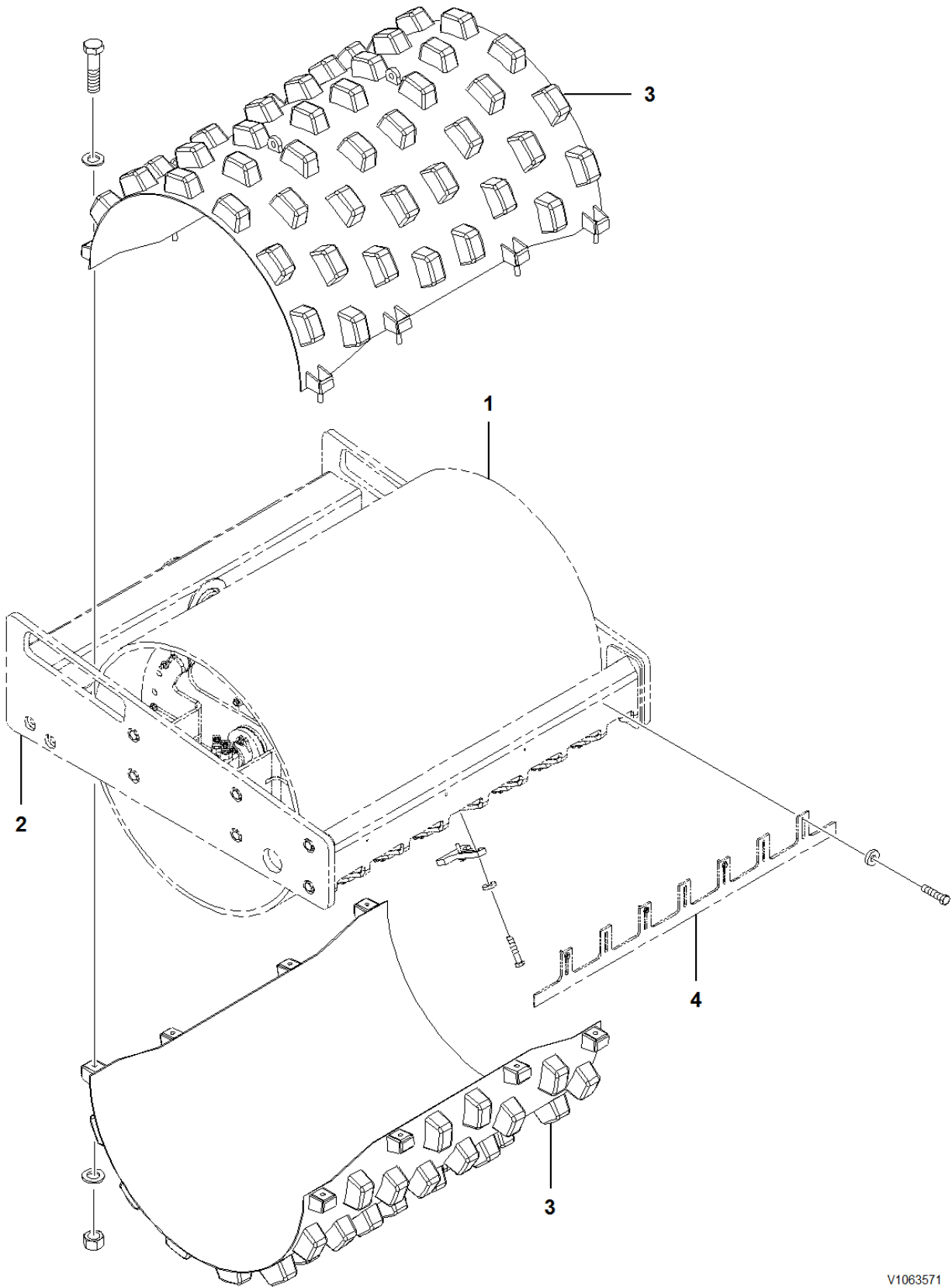

V1063571

Figure 1
Drum, description

1. Drum
2. Drum frame
3. Pad foot drum (option)
4. Scraper blade

Document Title: Drum eccentric, description	Function Group: 777	Information Type: Service Information	Date: 2015/9/10
Profile: COS, SD70D, SD77F [GB]			

Drum eccentric, description

The drum is equipped with an eccentric weight mounted internally which acts in a centrifugal manner. The purpose of the eccentric is to provide vibration to the drum, which aids in the compaction of the soil. The eccentric can be set to either high or low amplitude by activating the switch in the operator's platform, depending on the conditions of the soil.

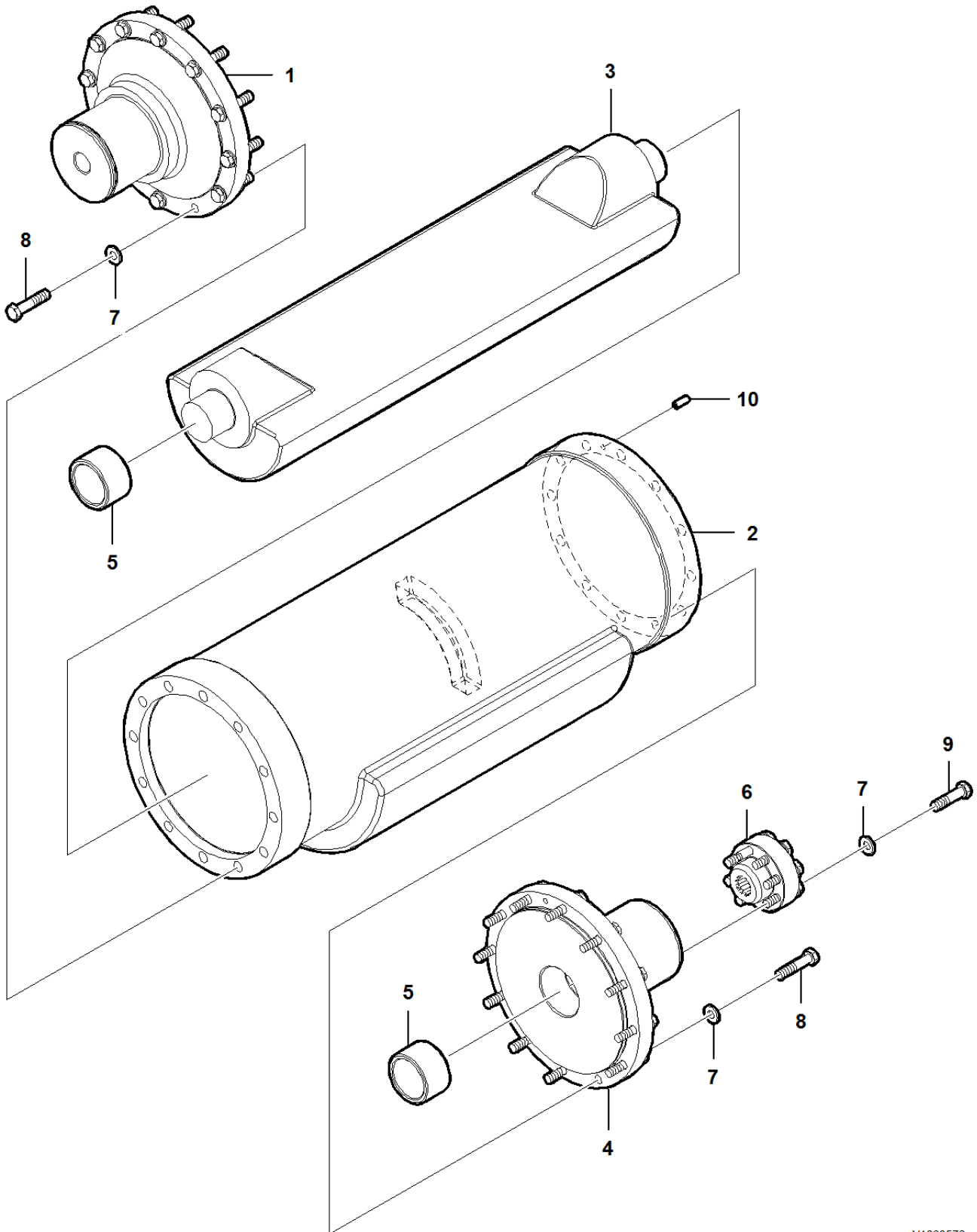

V1063576

Figure 1
Drum eccentric and components

1. Drum drive side journal
2. Eccentric weight - outer
3. Eccentric weight - inner
4. Vibration side drive journal
5. Bearing

6. Splined coupling
7. Washer
8. Hexagon screw
9. Hexagon screw
10. Pin



Download the full PDF manual instantly.

Our customer service e-mail:

aservicemanualpdf@yahoo.com