

Document Title: Tightening specifications	Function Group: torque, 715	Information Type: Service Information	Date: 2015/7/2 0
Profile: EXC, EC460C LD [GB]			

[Go back to Index Page](#)

Tightening torque, specifications

Protecting plate

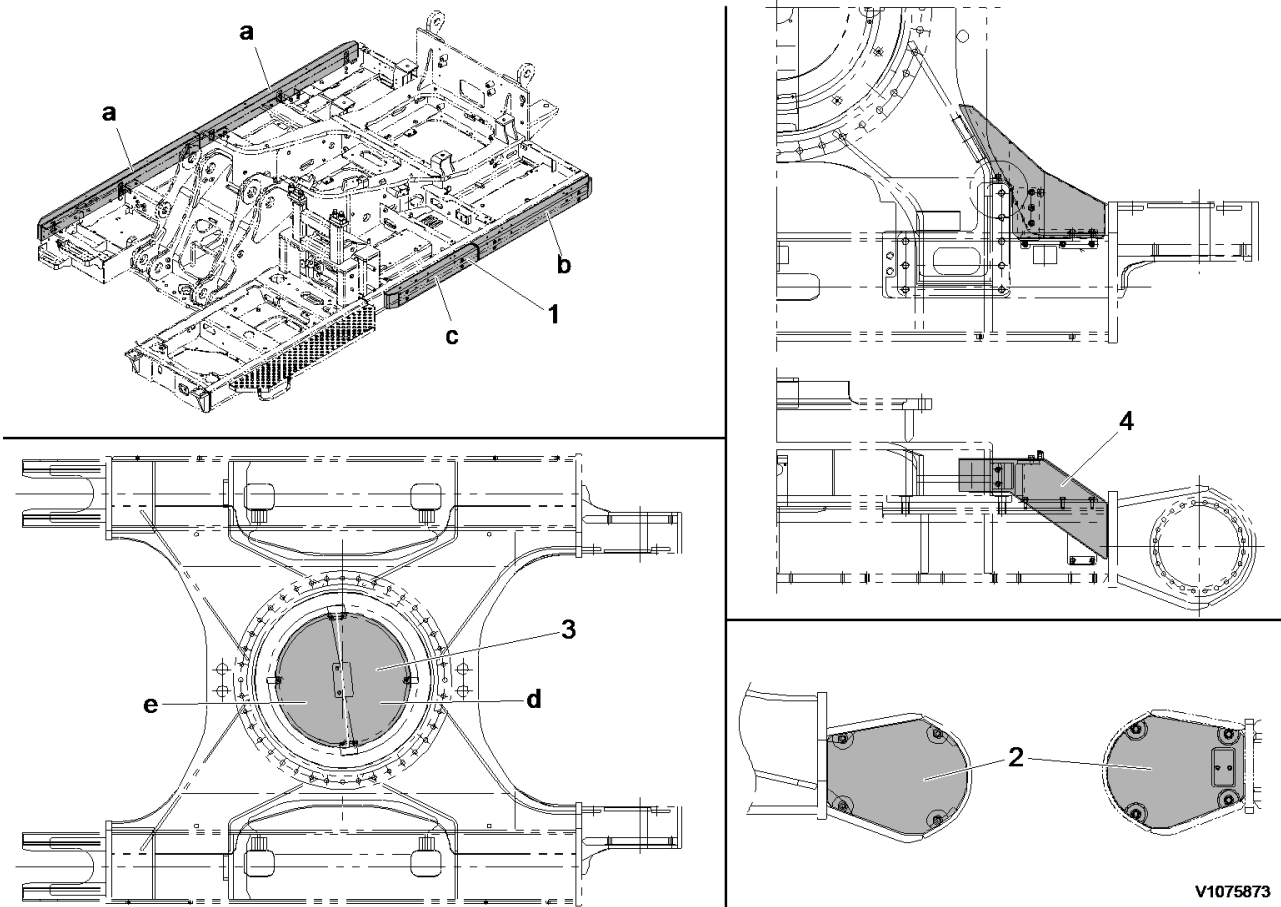

V1075873

Figure 1
Machine view, protecting plate

Tightening torque: Nm (kgf m) (lbf ft)

No.	Items	Weight: kg (lbs)	Tightening torque
1	Side (LH, RH) impact protection	a: 73 (161) b: 53 (117) c: 42 (93)	262 ±26 (26.7 ±2.7) (193 ±19)
2	Track motor protection cover (LH, RH)	LH: 11 (24) RH: 11 (24)	
3	Undercover Coat loctite (#277 or 609) on screws.	d: 37 (82) e: 30 (66)	265 ±29 (27 ±3) (195 ±22)
4	Retractable protection plates (LH, RH)	LH: 40 (88)	

Document Title: Tightening specifications	torque, 715	Function Group: 715	Information Type: Service Information	Date: 2015/7/2 0
Profile: EXC, EC460C LD [GB]				

[Go back to Index Page](#)

Tightening torque, specifications

Boom cylinder protecting guard, Demolition standard

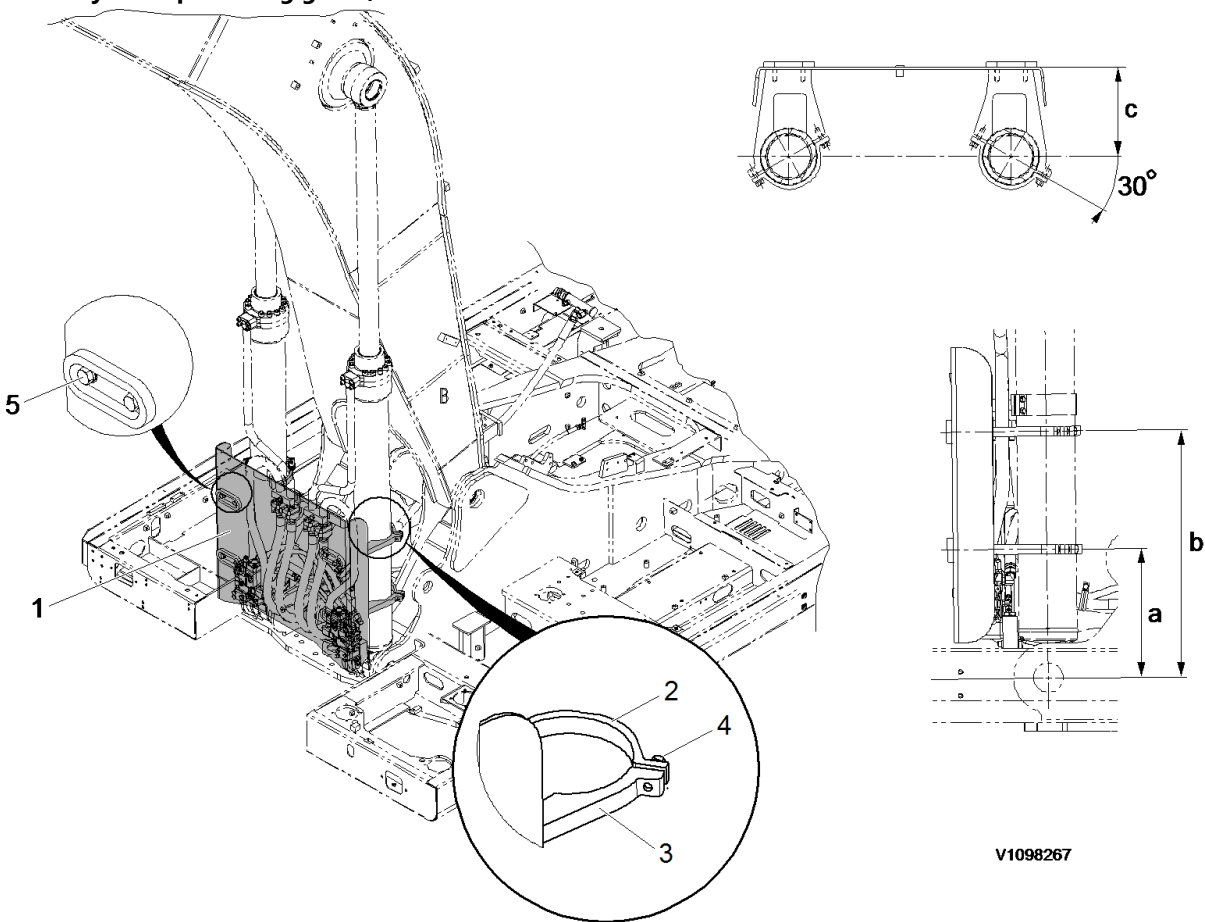

Figure 1
Boom cylinder protecting guard

Tightening torque

No.	Items	Weight: kg (lbs)	Tightening torque Nm (kgf m) (lbf ft)
1	Boom cylinder protecting guard	79.7 (175.7)	–
2	Clamp-lower	1.4 (3.1)	–
3	Clamp-upper	8.2 (18.1)	–
4	Mounting screws	8 EA	262 ±26.5 (26.7 ±2.7) (193 ±19.5)
5	Mounting screws	8 EA	
a	435 mm (17.13 inch)		

b	735 mm (28.94 inch)		
c	318 mm (12.52 inch)		

NOTE!

Mounting screws. Apply Loctite #277 or equivalent locking fluid.

Document Title: Protecting plate, description	Function Group: 715	Information Type: Service Information	Date: 2015/7/2 0
Profile: EXC, EC460C LD [GB]			

Protecting plate, description

Bucket cylinder protecting guard, Demolition

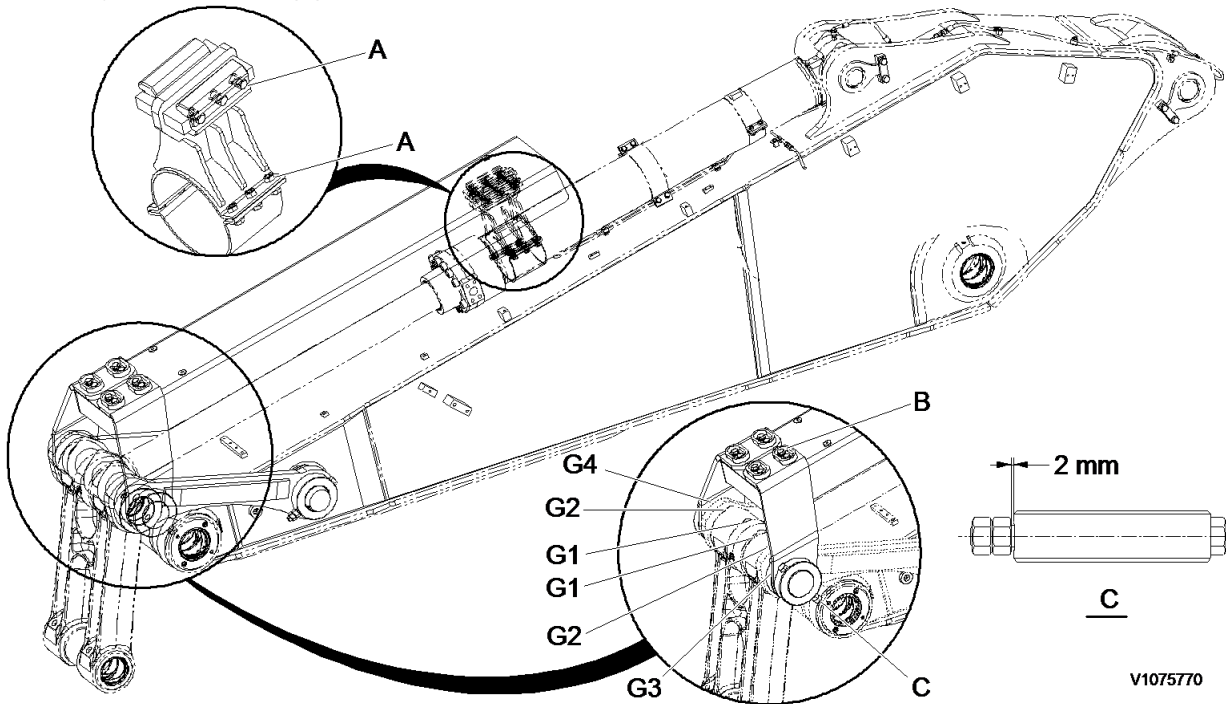

Figure 1
Protecting guard, bucket cylinder (standard)

Gap and shims

Items	Gap clearances: mm (inch)		Thick shims (1.0 t)	Thick shims (0.5 t)
	Minimum	Maximum	Quantity	Quantity
GAP 1	+0.5 (0.01969)	+2.5 (0.09843)	2	–
GAP 2	+2.0 (0.07874)	+3.0 (0.11811)	2	–
GAP 3	+0.5 (0.01969)	+1.5 (0.05906)	–	1
GAP 4	+0.5 (0.01969)	+1.5 (0.05906)	–	1
A	111 ±11 Nm (11.3 ±1.1 kgf m) (82 ±8 lbf ft)			
B	262 ±26 Nm (26.7 ±2.7 kgf m) (193 ±19 lbf ft)			
C	511.9 ±50.9 Nm (52.2 ±5.2 kgf m) (376.9 ±37.5 lbf ft)			

NOTE!

The item #4 and #5 before assembly coated grease on the hole inside.

Document Title: Boom cylinder protecting guard, removal	Function Group: 715	Information Type: Service Information	Date: 2015/7/2 0
Profile: EXC, EC460C LD [GB]			

[Go back to Index Page](#)

Boom cylinder protecting guard, removal

Op nbr 715-019

1. Park the machine in the service position B, see [091 Service positions](#).

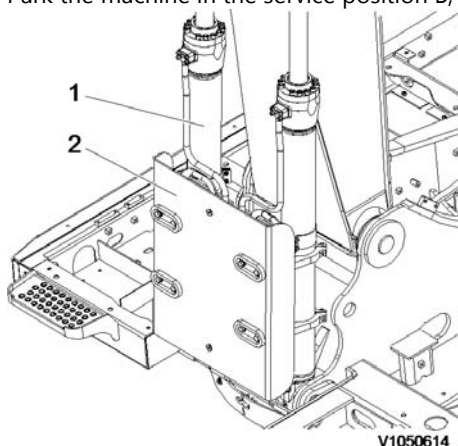

Figure 1
Position, boom cylinders

2. Raise boom cylinders (1), to Vertical position and stop engine.
3. Install I-bolt and sling guard (2) securely with a hoist.

NOTE!

Guard weight: 80 kg (176 lbs)



The parts are heavy. Take appropriate safety cautions when handling them.

4. Remove screws (3) and guard (2).

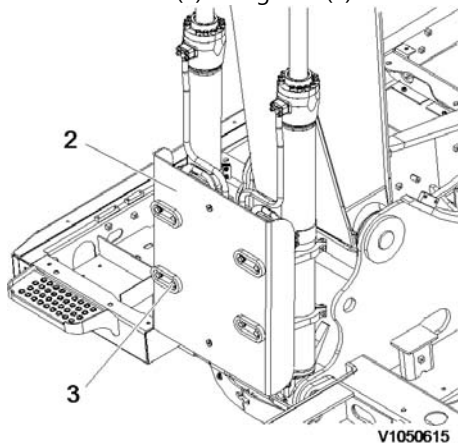

Figure 2
Remove, guard

5. Remove screws (4) and clamps (5).

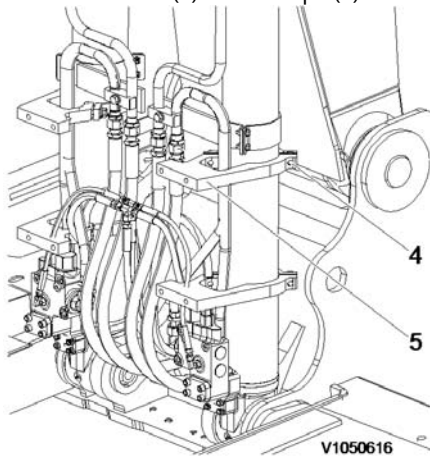

Figure 3
Remove, clamp

Document Title: Boom cylinder protecting guard, removal	Function Group: 715	Information Type: Service Information	Date: 2015/7/2 0
Profile: EXC, EC460C LD [GB]			

[Go back to Index Page](#)

Boom cylinder protecting guard, removal

Op nbr 715-019

1. Park the machine in the service position B, see [091 Service positions](#).

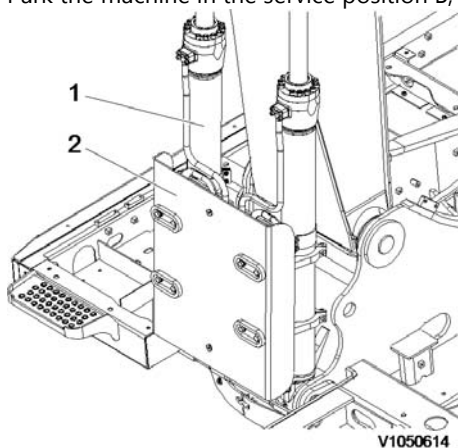

Figure 1
Position, boom cylinders

1. Boom cylinders
2. Sling guard

2. Raise boom cylinders, to Vertical position and stop engine.
3. Install the I-bolt and sling guard securely with a hoist.

NOTE!

Guard weight. See [715 Tightening torque specifications](#).



The parts are heavy. Take appropriate safety cautions when handling them.

4. Remove the screws and guard.

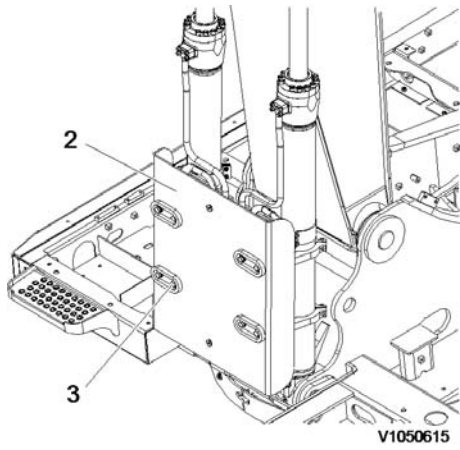

Figure 2
Remove, guard (2) and screws (3)

5. Remove the screws and clamps.

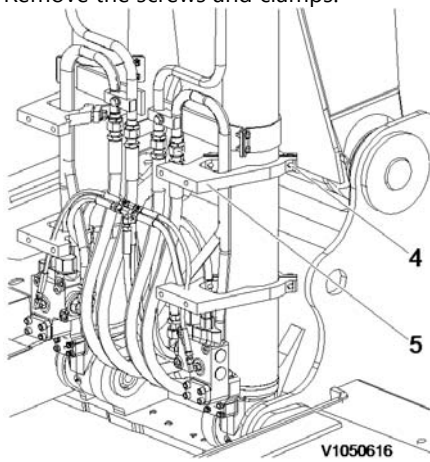

Figure 3
Remove, clamp (5) and screws (4)

Document Title: Boom cylinder protecting guard, installation	Function Group: 715	Information Type: Service Information	Date: 2015/7/20
Profile: EXC, EC460C LD [GB]			

[Go back to Index Page](#)

Boom cylinder protecting guard, installation

Op nbr 715-020

1. Park the machine in the service position B, see [091 Service positions](#).

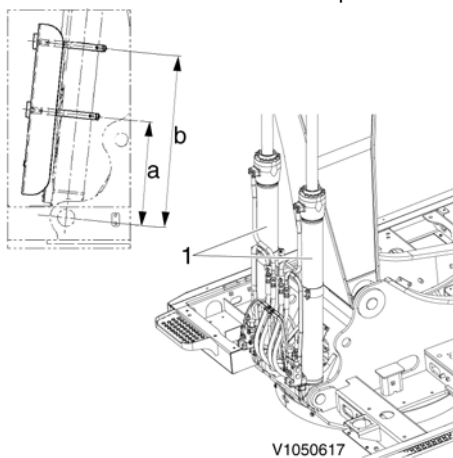

Figure 1
Marking, clamp position

- a. 435 mm (17 inch)
- b. 735 mm (29 inch)

2. Raise boom cylinders (1), to Vertical position and stop engine.
3. Mark clamp location on each the boom cylinder (1).
4. Install screws (3) and clamps (2), don't over tighten the clamps (2).

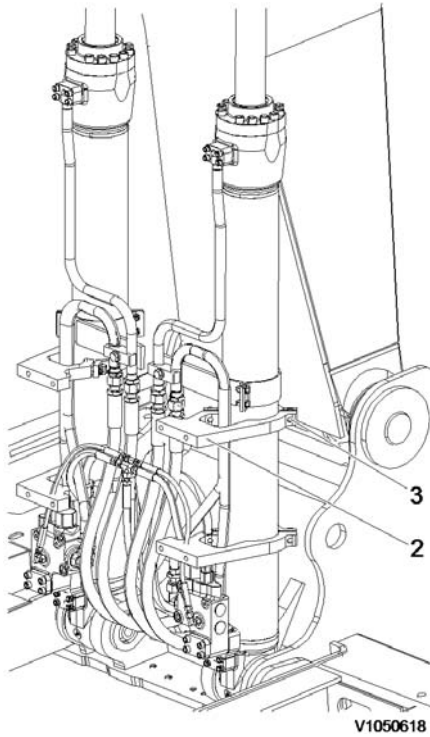

Figure 2
Install, clamp

5. Sling guard (4) securely with a hoists and install screws (5).

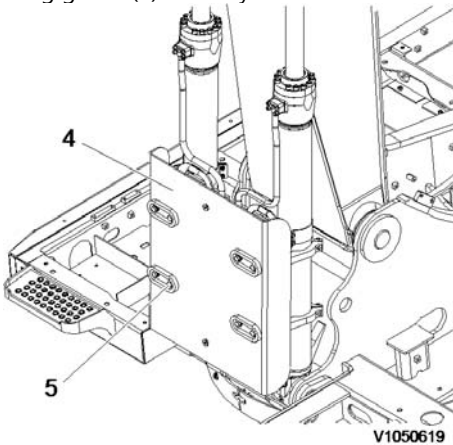

Figure 3
Install, guard

NOTE!

Apply loctite on screws (5).

NOTE!

Guard weight: 80 kg (176 lbs)

Tightening torque: 262 ±26 Nm (193 ±19 lbf ft)



The parts are heavy. Take appropriate safety cautions when handling them.

6. Before installing screws (6) apply loctite.

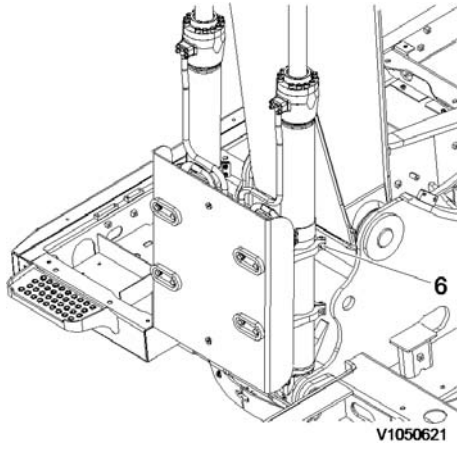

Figure 4
Install, clamp screw

NOTE!

Tightening torque: 262 ± 26 Nm (193 ± 19 lbf ft)

7. Check for interference of guard by operating the boom cylinders.

Document Title: Boom cylinder protecting guard, installation	Function Group: 715	Information Type: Service Information	Date: 2015/7/2 0
Profile: EXC, EC460C LD [GB]			

[Go back to Index Page](#)

Boom cylinder protecting guard, installation

Op nbr 715-020

1. Park the machine in the service position B, see [091 Service positions](#).

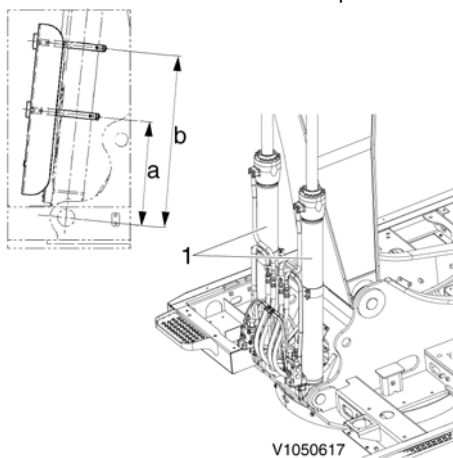

Figure 1
Marking, clamp position

- a. XXX mm (XX inch)
- b. XXX mm (XX inch)

NOTE!

See [715 Tightening torque, specifications](#).

2. Raise boom cylinders, to Vertical position and stop engine.
3. Mark clamp location on each the boom cylinder.
4. Install the screws and clamps, don't over tighten the clamps.

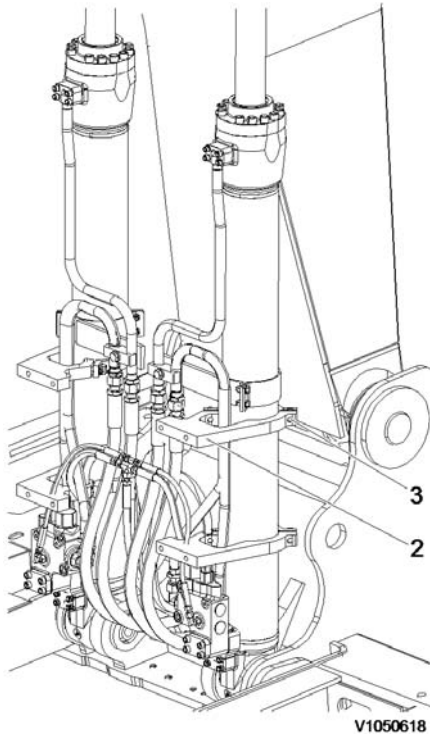

Figure 2
Install, clamp

- 2. Clamps
- 3. Screws

- 5. Sling guard securely with a hoists and install the screws.

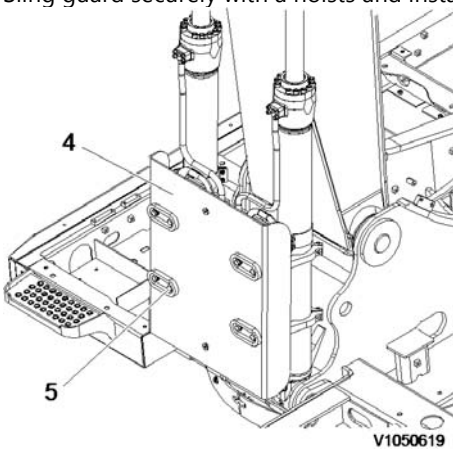

Figure 3
Install, guard

- 4. Sling guard
- 5. Screws

NOTE!

Apply loctite on screws (5).

NOTE!

Guard weight and tightening torque. See [715 Tightening torque, specifications](#).



The parts are heavy. Take appropriate safety cautions when handling them.

- 6. Before installing screws apply loctite.

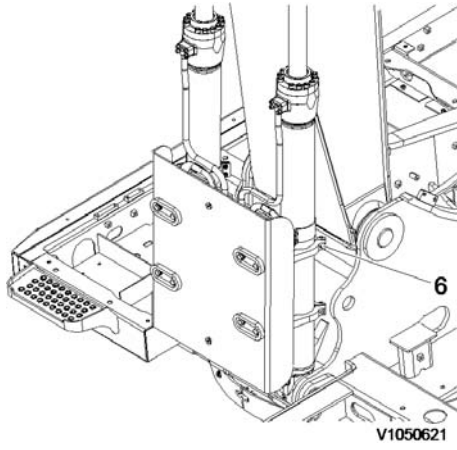

Figure 4
Install, clamp screw (6)
NOTE!

Tightening torque. See [715 Tightening torque specifications](#).

7. Check for interference of guard by operating the boom cylinders.



Download the full PDF manual instantly.

Our customer service e-mail:

aservicemanualpdf@yahoo.com