

FOREWORD

This manual covers the service procedures of the TOYOTA ELECTRIC POWERED FORKLIFT 7FBE10 to 20 series.

Please use these manuals for providing quick, correct servicing of the corresponding forklift models.

This manual deals with the above models as of February 2003. Please understand that disagreement can take place between the descriptions in the manual and actual vehicles due to change in design and specifications. Any change or modifications thereafter will be informed by Toyota Industrial Equipment Parts & Service News.

TOYOTA Material Handling Company
A Division of TOYOTA INDUSTRIES CORPORATION

SECTION INDEX

NAME	SECTION
GENERAL	0
BATTERY	1
CHARGER (OPT)	2
CONTROLLER	3
MULTI-DISPLAY FUNCTIONS	4
TROUBLESHOOTING	5
MOTOR	6
DRIVE UNIT & FRONT AXLE	7
REAR AXLE	8
STEERING	9
BRAKE	10
BODY & FRAME	11
MATERIAL HANDLING SYSTEM	12
MAST	13
CYLINDER	14
OIL PUMP	15
OIL CONTROL VALVE	16
SAS FUNCTIONS (OPT)	17
APPENDIX	18

GENERAL

	Page		Page
VEHICLE EXTERIOR VIEW.....	0-2	HIGH PRESSURE HOSE FITTING	
VEHICLE MODELS.....	0-3	TIGHTENING TORQUE.....	0-17
FRAME NUMBER.....	0-3	RECOMMENDED LUBRICANT	
HOW TO USE THIS MANUAL	0-4	QUANTITY AND TYPES	0-18
EXPLANATION METHOD	0-4	LUBRICATION CHART.....	0-19
TERMINOLOGY.....	0-5	PERIODIC MAINTENANCE.....	0-20
ABBREVIATIONS.....	0-5	PERIODIC REPLACEMENT OF	
SI UNITS	0-6	PARTS AND LUBRICANTS	0-25
OPERATING TIPS	0-7		
GENERAL INSTRUCTIONS.....	0-7		
JACK-UP POINT	0-8		
HOISTING THE VEHICLE	0-9		
WIRE ROPE SUSPENSION ANGLE			
LIST	0-10		
SAFE LOAD FOR EACH WIRE ROPE			
SUSPENSION ANGLE	0-10		
MEMBER WEIGHTS.....	0-11		
TOWING THE VEHICLE.....	0-11		
ELECTRICAL PARTS			
INSPECTION	0-12		
NOTES ON SAS	0-14		
STANDARD BOLT & NUT			
TIGHTENING TORQUE.....	0-15		
BOLT STRENGTH CLASS			
IDENTIFICATION METHOD	0-15		
TIGHTENING TORQUE TABLE	0-16		
PRECOATED BOLTS	0-17		

VEHICLE EXTERIOR VIEW

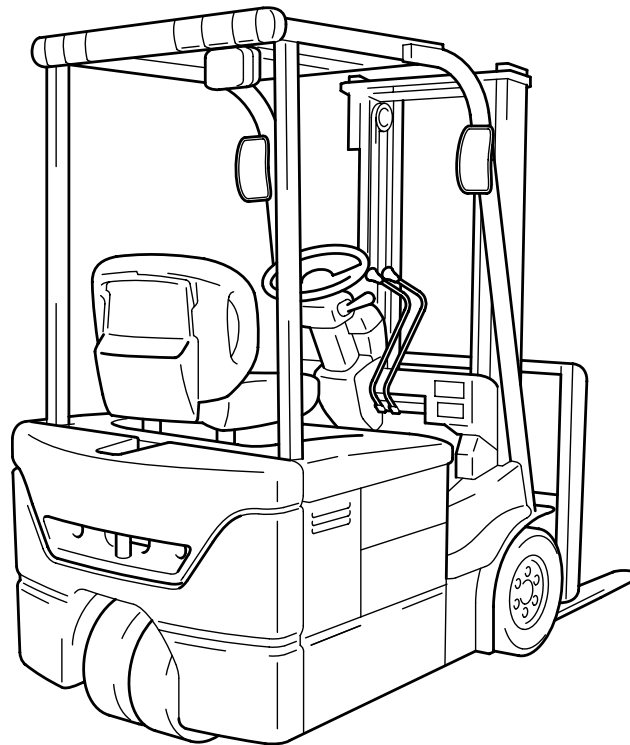
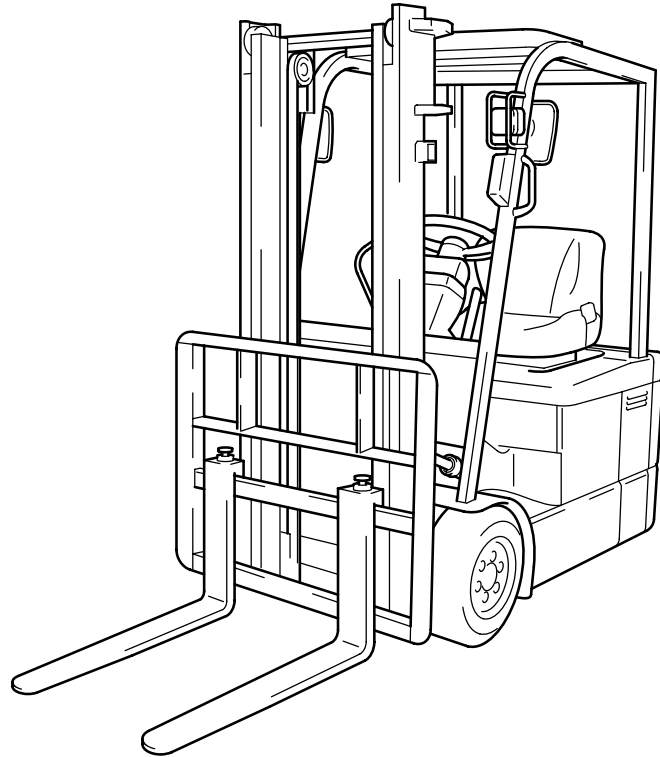

VEHICLE MODELS

Vehicle model code	Payload (ton)	Vehicle Model	Control method	Voltage (V)
10	1.0	7FBE10	AC microcomputer controller	48
13	1.25	7FBE13	↑	↑
15	1.5	7FBE15	↑	↑
18	1.75	7FBE18	↑	↑
20	2.0	7FBE20	↑	↑

0

FRAME NUMBER

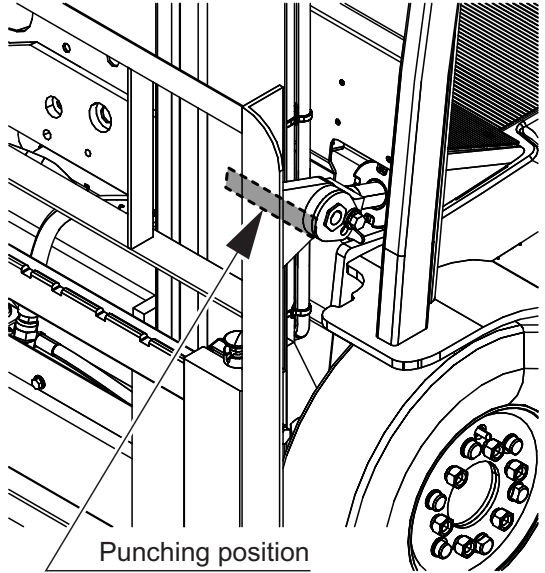
Vehicle model	Drive motor model	Punching format	Punching position
7FBE10	AR09	7FBE13-50011	 <p>Punching position</p>
7FBE13			
7FBE15		7FBE18-50011	
7FBE18			
7FBE20		7FBE20-50011	

HOW TO USE THIS MANUAL

EXPLANATION METHOD

1. Operating procedure

(1) Operating procedures are described using either pattern A or pattern B.

Pattern A: Each step of the operation is explained with its own illustration.

Pattern B: The entire operation is indicated by step numbers in one illustration, followed by cautions, notes, and point operations.

Example of pattern B

DISASSEMBLY · INSPECTION · REASSEMBLY

Tightening torque unit $T=N \cdot m(kg \cdot m)[ft \cdot lbf]$

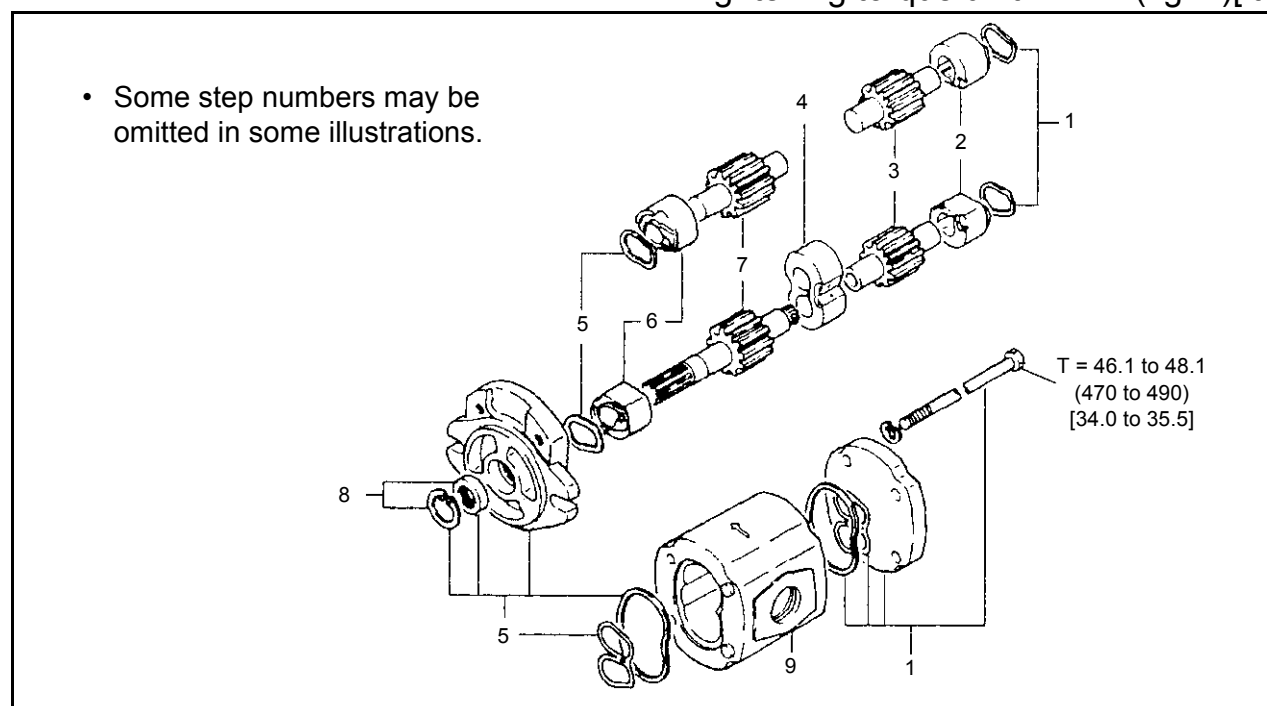

Disassembly Procedure

- 1 Remove the cover. [Point 1]
- 2 Remove the bushing. [Point 2]
- 3 Remove the gear.

← Operation to be explained

Point Operations

[POINT 1]

Disassembly:

Make match marks before removing the pump cover

Explanation of operation point with illustration

[POINT 2]

Inspection:

Measure the bushing inside diameter.

Limit 19.12 mm

1. How to read component figures

- (1) The component figures use the illustration in the parts catalog for the vehicle model. Please refer to the catalog to check the part name.

(Example)

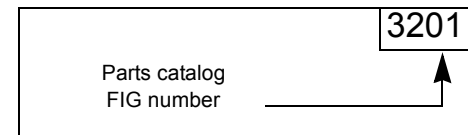

2. Matters omitted from this manual

- (1) This manual omits descriptions of the following jobs, but perform them in actual operation:
- Cleaning and washing of removed parts as required
 - Visual inspection (partially described)

0

TERMINOLOGY

CAUTION:

Important matters, negligence of which may cause accidents. Be sure to observe them.

NOTE:

Important items, negligence of which may cause accidents, or matters in operating procedure which require special attention.

Standard: Value showing the allowable range in inspection or adjustment

Limit: The maximum or minimum value allowed in inspection or adjustment.

ABBREVIATIONS

Abbreviation	Meaning	Abbreviation	Meaning
ASSY	Assembly	SAE	Society of Automotive Engineers (USA)
ATT	Attachment	SAS	System of active stability
LH	Left Hand	SST	Special Service Tool
L/	Less	STD	Standard
OPT	Option	T=	Tightening Torque
O/S	Oversize	OOT	Number of teeth (OOT)
PS system	Power Steering	U/S	Undersize
RH	Right Hand	W/	With

SI UNITS

Meaning of SI

This manual uses SI units. SI represents the International System of Units, which was established to unify the various systems of units used in the past for smoother international technical communication.

New Units Adopted in SI

Item	New unit	Conventional unit	Conversion rate* ¹ (1 [conventional unit] = X [SI unit])
Force* ²	N (newton)	kgf	1 kgf = 9.80665 N
Torque* ² (Moment)	N·m	kgf·cm	1 kgf·cm = 9.80665 N·m
Pressure* ²	Pa (pascal)	kgf/cm ²	1 kgf/cm ² = 98.0665 kPa = 0.0980665 MPa
↑	↑	mmHg	1 mmHg = 0.133322 kPa
Revolving speed	rpm	rpm	1 rpm = 1 r/min
Spring con-	N/mm	kgf/mm	1 kgf/mm = 9.80665 N/mm
Volume	l	cc	1 cc = 1 ml
Power	W	PS system	1 PS = 0.735499 kW
Heat quantity	W·h	cal	1 kcal = 1.16279 W·h
Specific fuel	g/W·h	g/PS·h	1 g/PS·h = 1.3596 g/kW·h

<Reference>

* 1: X represents the value in SI units as converted from 1 [in conventional units], which can be used as the rate for conversion between conventional and SI units.

* 2: In the past, kilogram [kg] representing mass was often used in place of weight kilogram [kgf], which should be used as the unit of force.

Conversion between Conventional and SI Units

Equation for conversion

Value in SI unit = Conversion rate × Value in conventional unit	Conversion rate: Figure corresponding to X in the conversion rate column in the table above
Value in conventional unit = Value in SI unit ÷ Conversion rate	

When converting, change the unit of the value in conventional or SI units to the one in the conversion rate column in the table above before calculation. For example, when converting 100 W to the value in conventional unit PS, first change it to 0.1 kW and divide by the conversion rate 0.735499.

OPERATING TIPS

GENERAL INSTRUCTIONS

1. Skillful operation
 - (1) Prepare the tools, necessary measuring instruments (circuit tester, megohmmeter, oil pressure gauge, etc.) and SSTs before starting operation.
 - (2) Check the cable color and wiring state before disconnecting any wiring.
 - (3) When overhauling functional parts, complicated sections or related mechanisms, arrange the parts neatly to prevent confusion.
 - (4) When disassembling and inspecting a precision part such as the control valve, use clean tools and operate in a clean location.
 - (5) Follow the specified procedures for disassembly, inspection and reassembly.
 - (6) Always replace gaskets, packing, O-rings, self-locking nuts and cotter pins with new ones each time they are disassembled.
 - (7) Use genuine Toyota parts for replacement.
 - (8) Use specified bolts and nuts and observe the specified tightening torque when reassembling. (Tighten to the medium value of the specified tightening torque range.) If no tightening torque is specified, use the value given in the "standard tightening torque table".
2. Protection of functional parts (battery operated vehicles)
 - (1) Before connecting the battery plug after vehicle inspection or maintenance, thoroughly check each connector for any connection failure or imperfect connection.
Failure or imperfect connection of connectors related to controllers, especially, may damage elements inside the controllers.
3. Defect status check
Do not start disassembly and/or replacement immediately, but first check that disassembly and/or replacement is necessary for the defect.
4. Waste fluid disposal
Always use a proper container when draining waste fluid from the vehicle.
Careless discharge of oil, fuel, coolant, oil filter, battery or other harmful substance may adversely affect human health and the environment. Always collect and sort well, and ask specialized companies for appropriate disposal.

WIRE ROPE SUSPENSION ANGLE LIST

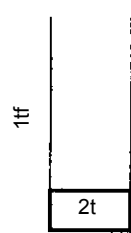
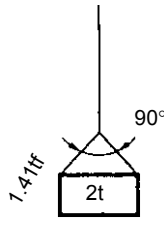
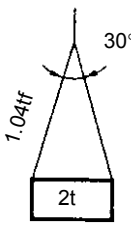
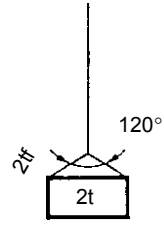
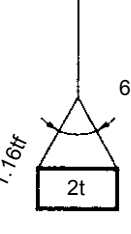
Suspension Angle	Tension	Compression	Suspension method	Suspension Angle	Tension	Compression	Suspension method
0°	1.00 time	0 time		90°	1.41 time	1.00 time	
30°	1.04 time	0.27 time		120°	2.00 time	1.73 time	
60°	1.16 time	0.58 time					

SAFE LOAD FOR EACH WIRE ROPE SUSPENSION ANGLE

Unit: N (tf) [lbf]

Rope diameter	Cutting load	Single-rope	Two-rope suspension					four-rope suspension			
		0°	0°	30°	60°	90°	0°	30°	60°	90°	
6 mm (0.24 in)	21380 (2.18) [4807]	3040 (0.31) [683.6]	6080 (0.62) [1367]	5880 (0.6) [1323]	5200 (0.53) [1169]	4310 (0.44) [970]	12160 (1.24) [2734]	11770 (1.2) [2646]	10400 (1.06) 2337	8630 (0.88) [1940]	
8 mm (0.32 in)	31480 (3.21) [7078]	4410 (0.45) [992.3]	8830 (0.9) [1985]	8530 (0.87) [1918]	7650 (0.78) [1720]	6280 (0.64) [1411]	17650 (1.8) [3969]	17060 (1.74) [3937]	15300 (1.56) [3440]	12550 (1.28) [2322]	
10 mm (0.4 in)	49230 (5.02) [11690]	6960 (0.71) [1565.6]	14020 (1.43) [3153]	13440 (1.37) [3021]	11770 (1.2) [2646]	9810 (1.0) [2205]	27460 (2.8) [6174]	26480 (2.7) [5954]	23540 (2.4) [5292]	19610 (2.0) [4410]	
12.5 mm (0.5 in)	76880 (7.84) [17387]	10980 (1.12) [2469.5]	21570 (2.2) [4851]	21280 (2.1) [4631]	18630 (1.9) [4190]	14710 (1.5) [3308]	43150 (4.4) [9702]	41190 (4.2) [9261]	37270 (3.8) [8379]	29420 (3.0) [6615]	
14 mm (0.56 in)	96400 (9.83) [21675]	13730 (1.4) [3087]	27460 (2.8) [6174]	26480 (2.7) [5954]	23540 (2.4) [5292]	18630 (1.9) [4190]	54920 (5.6) [12348]	52960 (5.4) [11907]	47070 (4.8) [10584]	37270 (3.8) [8379]	

MEMBER WEIGHTS

Unit: kg (lbs)

Member	Vehicle model	Weight
BATTERY ASSY	See P1-2	
Drive motor ASSY	All Models	Approx. 37 (82)
Pump motor ASSY	All Models	Approx. 31 (68)
Front axle ASSY W/ drive motor ASSY	All Models	Approx. 122 (269)
Rear axle ASSY W/ rear axle cylinder ASSY	All Models	Approx. 45 (99)
Counterweight	7FBE10	Approx. 405 (893)
	7FBE13	Approx. 598 (1319)
	7FBE15	Approx. 697 (1537)
	7FBE18	Approx. 853 (1881)
	7FBE20	Approx. 1040 (2293)
Mast ASSY W/ lift bracket (W/ lift cylinder, L/ fork, Lifting height 3000mm, V mast)	7FBE10 to 7FBE18	330 (730)
	7FBE20	400 (880)
Vehicle weight	7FBE10	2225 (4906)
	7FBE13	2425 (5347)
	7FBE15	2685 (5920)
	7FBE18	2840 (6262)
	7FBE20	3155 (6957)

TOWING THE VEHICLE

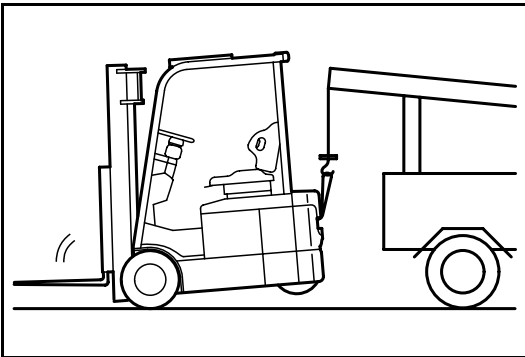

Note the cautions below when towing the vehicle.

1. Lift the rear wheels for towing
2. The traveling speed when towing must not exceed the maximum traveling speed of the forklift.
3. Before starting towing, always set the key switch to OFF and the direction switch to the neutral position.
4. Before towing, either remove the fork or take action to prevent the fork from coming into contact with the ground due to bouncing.

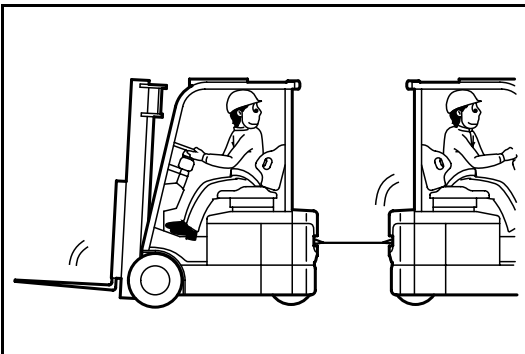

ELECTRICAL PARTS INSPECTION

1. Always disconnect the battery plug before inspecting or servicing electrical parts.
2. Pay sufficient attention when handling electronic parts.

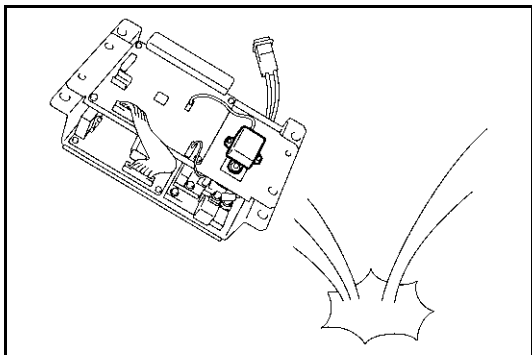

- (1) Never subject electronic parts, such as computers and relays, to impact.
- (2) Never expose electronic parts to high temperature or moisture.
- (3) Do not touch connector terminals, as they may be deformed or damaged due to static electricity.

3. Use a circuit tester that matches the object and purpose of measurement.
 Analog type: This type is convenient for observing movement during operation and the operating condition. Measured value is only a reference

Digital type: A fairly accurate reading is possible. However, it is difficult to observe operation or movement.

- (1) Difference between results of measurement with analog and digital types
 * The results of measurements using the analog type and the digital type may be different.
 Differences between the polarities of the analog type and the digital type are described below.

1) Analog circuit tester

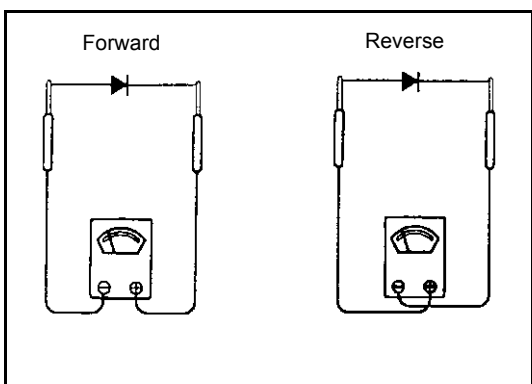

Example of measurement result
 Tester range: kΩ range

	Analog type
Forward	Continuity
	11 kΩ
Reverse	No continuity
	∞

2) Digital circuit tester

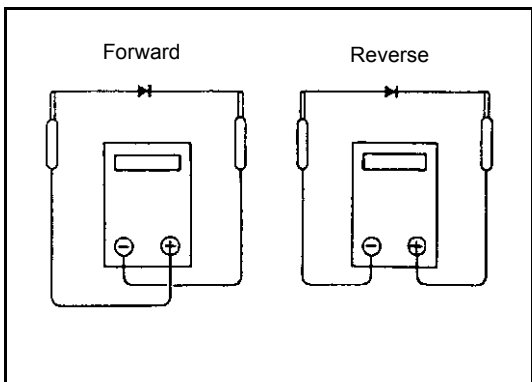

Example of measurement result
 Tester range: 2 MΩ range

	Digital type
Forward	No continuity
	1
Reverse	Continuity
	2 MΩ

(2) Difference in result of measurement with a circuit tester

The circuit tester power supply voltage depends on the tester type. 1.5 V, 3.0 V or 6.0 V is used. The resistance of a semiconductor, such as a diode, varies with the circuit tester power supply voltage.

The diode characteristics are shown in the figure below.

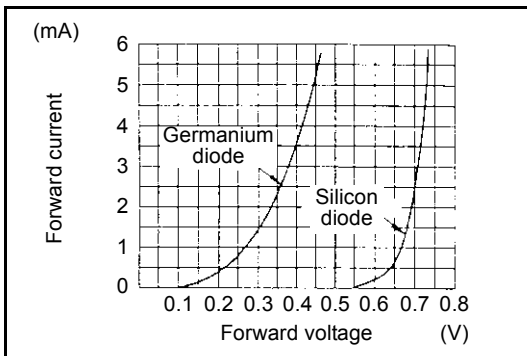

The resistance values of the same semiconductor measured with two types of circuit testers having different power supply voltages are different.

This manual describes the results of measurement with a circuit tester whose power supply voltage is 3.0 V.

(3) Difference in measurement result by measurement range (analog type)

In the analog type circuit tester, changing the measurement range switches over the internal circuit to vary the circuit resistance. Even when the same diode is measured, the measurement result varies with the measurement range.

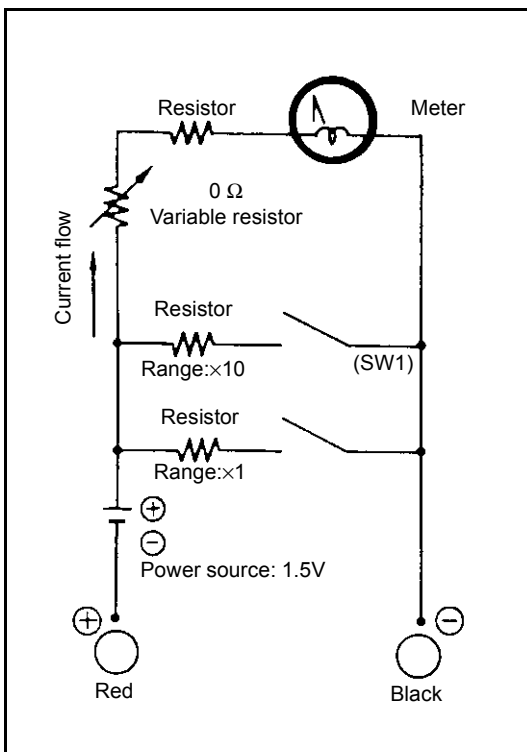

Always use the range described in the repair manual for measurement.

NOTES ON SAS

1. For the explanations of SAS functions and operation, also see “New Model Feature 7FBE10 to 20 Pub. No. PE314”.
2. See page 17-6 FOR REPAIR WORK of this repair manual before servicing.
3. If repair or replacement is performed in any section of the vehicle that relates to SAS function, perform necessary matching to ensure proper SAS function (see page 4-47).
4. always be sure to operate the vehicle carefully. Be aware of the difference in control features between with and without SAS.
5. Many precision valves are used in the SAS oil control valves. When disassembling or replacing hydraulic parts (valves, piping, etc.), be sure to clean the parts before installation. Periodic change of the hydraulic oil is also very important.
6. As the vehicle is equipped with high-precision electronic devices, modification of electrical parts may cause vehicle failure. Be sure to use genuine Toyota parts for replacement and installation of the electrical parts (auxiliary equipment, optional parts, etc.).

STANDARD BOLT & NUT TIGHTENING TORQUE







Tightening torque of standard bolts and nuts are not indicated throughout the manual.

Use the charts and table below to judge the standard tightening torque.

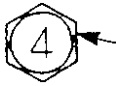
1. Find the class of the bolt strength on the table below and then find the bolt tightening torque on the tightening torque table.
2. The nut tightening torque can be judged from its corresponding bolt type.

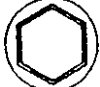
BOLT STRENGTH CLASS IDENTIFICATION METHOD

Identification by bolt shape

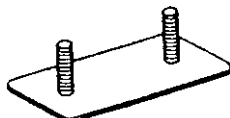
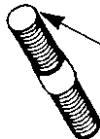
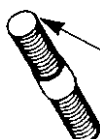
	Shape and class	Class
Hexagon head bolt	 Bolt with raised or etched numeral on head	4 = 4T 5 = 5T 6 = 6T 7 = 7T 8 = 8T
Hexagon bolt (standard)	 No mark	4T
Hexagon flange bolt	 No mark	4T
Hexagon head bolt (standard)	 Bolt with two raised lines on head	5T
Hexagon flange bolt	 Bolt with two raised lines on head	6T
Hexagon head bolt (standard)	 Bolt with three raised lines on head	7T
Hexagon head bolt (standard)	 Bolt with four raised lines on head	8T
Welded bolt		4T
Stud bolt	 No mark	4T
	 2 mm groove(s) on one/both edge(s)	6T

Identification by part No.

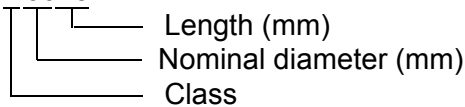
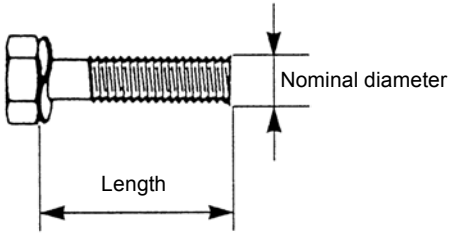
Hexagon head bolt	<p>Part No. 91611-40625</p> 
Stud bolt	<p>Part No. 92132-40614</p> 

TIGHTENING TORQUE TABLE

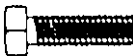
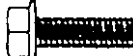
Class	Nominal diameter mm	Pitch mm	Standard tightening torque					
			Hexagon head bolt 			Hexagon flange bolt 		
			N·m	kgf·cm	ft·lbf	N·m	kgf·cm	ft·lbf
4T	6	1.0	5.4	55	48in·lbf	5.9	60	52in·lbf
	8	1.25	13	130	9	14	145	10
	10	1.25	25	260	19	28	290	21
	12	1.25	47	480	35	53	540	39
	14	1.5	75	760	55	83	850	61
	16	1.5	113	1150	83	—	—	—
5T	6	1.0	6.4	65	56in·lbf	7.5	75	65in·lbf
	8	1.25	16	160	12	18	175	13
	10	1.25	32	330	24	36	360	26
	12	1.25	59	600	43	65	670	48
	14	1.5	91	930	67	100	1050	76
	16	1.5	137	1400	101	157	1600	116
6T	6	1.0	7.8	80	69in·lbf	8.8	90	78in·lbf
	8	1.25	19	195	14	21	215	16
	10	1.25	38	400	29	43	440	32
	12	1.25	72	730	53	79	810	59
	14	1.5	110	1100	80	123	1250	90
	16	1.5	170	1750	127	191	1950	141
7T	6	1.0	11	110	8	12	120	9
	8	1.25	25	260	19	28	290	21
	10	1.25	52	530	38	58	590	43
	12	1.25	95	970	70	103	1050	76
	14	1.5	147	1500	108	167	1700	123
	16	1.5	226	2300	166	—	—	—
8T	6	1.0	12	125	9	14	145	9
	8	1.25	29	300	22	32	330	24
	10	1.25	61	620	45	68	690	50
	12	1.25	108	1100	80	123	1250	90
	14	1.5	172	1750	127	196	2000	145
	16	1.5	265	2700	195	299	3050	221

PRECOATED BOLTS

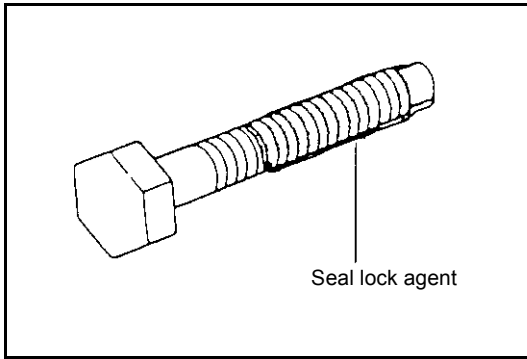

1. Do not replace or restore a precoated bolt as it is in the following cases:
 - (1) After it has been removed.
 - (2) When it has been moved by tightness check, etc. (loosened or tightened)

NOTE:

For torque check, tighten the bolt at the lower limit of the allowable tightening torque range; if the bolt moves, retighten it according to the steps below.

2. How to reuse precoated bolts
 - (1) Wash the bolt and threaded hole.
(The threaded hole must be washed even when replacing the bolt with a new one)
 - (2) Completely dry the washed parts by blowing with air.
 - (3) Apply a specified seal lock agent to the threaded portion of the bolt.

HIGH PRESSURE HOSE FITTING TIGHTENING TORQUE

1. When connecting a high pressure hose, wipe the hose fitting and corresponding nipple contact surfaces with a clean cloth to remove foreign matter and dirt. Also check that there are no dents or other damage on the contact surfaces before installation.
2. When connecting the high pressure hose, hold the hose to align the fitting with the nipple and tighten the fitting.
3. The maximum tightening torque must not exceed twice the standard tightening torque.

Nominal diameter of screw	Tightening torque standard N·m (kgf·cm) [ft·lbf]		Inside diameter of hose mm (in)
	Standard	Tightening range	
7/16-20UNF	25 (50) [18.1]	24 to 26 (240 to 270) [17.4 to 19.5]	6 (0.24)
9/16-18UNF	49 (500) [36.2]	47 to 52 (480 to 530) [34.7 to 38.3]	9 (0.35)
3/4-16UNF	59 (600) [43.4]	56 to 62 (570 to 630) [41.2 to 45.6]	12 (0.47)
7/8-14UNF	59 (600) [43.4]	56 to 62 (570 to 630) [41.2 to 45.6]	12 (0.47)
7/8-14UNF	78 (800) [57.9]	74 to 82 (740 to 840) [53.5 to 60.8]	15 (0.59)
1•1/16-12UNF	118 (1200) [86.8]	112 to 123 (1140 to 1250) [82.5 to 90.4]	19 (0.75)
1•5/16-12UNF	137 (1400) [101.3]	130 to 144 (1330 to 1470) [96.2 to 106.4]	25 (0.98)
PF1/4	25 (250) [18.1]	24 to 26 (240 to 270) [17.4 to 19.5]	6 (0.24)
PF3/8	49 (500) [36.2]	47 to 52 (480 to 530) [34.7 to 38.3]	9 (0.35)
PF1/2	59 (600) [43.4]	56 to 62 (570 to 630) [41.2 to 45.6]	12 (0.47)
PF3/4	118 (1200) [86.8]	112 to 123 (1140 to 1250) [82.5 to 90.4]	19 (0.75)
PF1	137 (1400) [101.3]	130 to 144 (1330 to 1470) [96.2 to 106.4]	25 (0.98)

RECOMMENDED LUBRICANT QUANTITY AND TYPES

Application	Type	Capacity
Drive unit	Castle hypoid gear oil W (API GL-4, SAE 75W-80)	Approx. 0.4 ℓ (0.11 US gal) (Until purring out from the filler port)
Hydraulic oil	STD: Castle hydraulic oil (ISO VG32) Cold storage vehicle: Mobil Aero HFE	See "Hydraulic oil level by lifting height" below
Chassis parts	MP grease Chassis grease special Esso beacon 325	Appropriate amount
Battery	Distilled water	Appropriate amount

Hydraulic oil level by lifting height

Unit: ℓ (US gal)

Lifting height		V mast	SV mast	FV Mast	FSV Mast
To 3000mm (118 in)	Capacity	14 (3.70)	14 (3.70)	17 (4.49)	—
	Hydraulic oil level in the tank	12.4 (3.27)			
To 4000mm (157.5 in)	Capacity	15 (3.96)	15 (3.96)	19 (5.01)	16 (4.22)
	Hydraulic oil level in the tank	14.2 (3.75)			
To 6000mm (236 in)	Capacity	18 (4.75)	—	—	19 (5.01)
	Hydraulic oil level in the tank	17.2 (4.54)			

LUBRICATION CHART

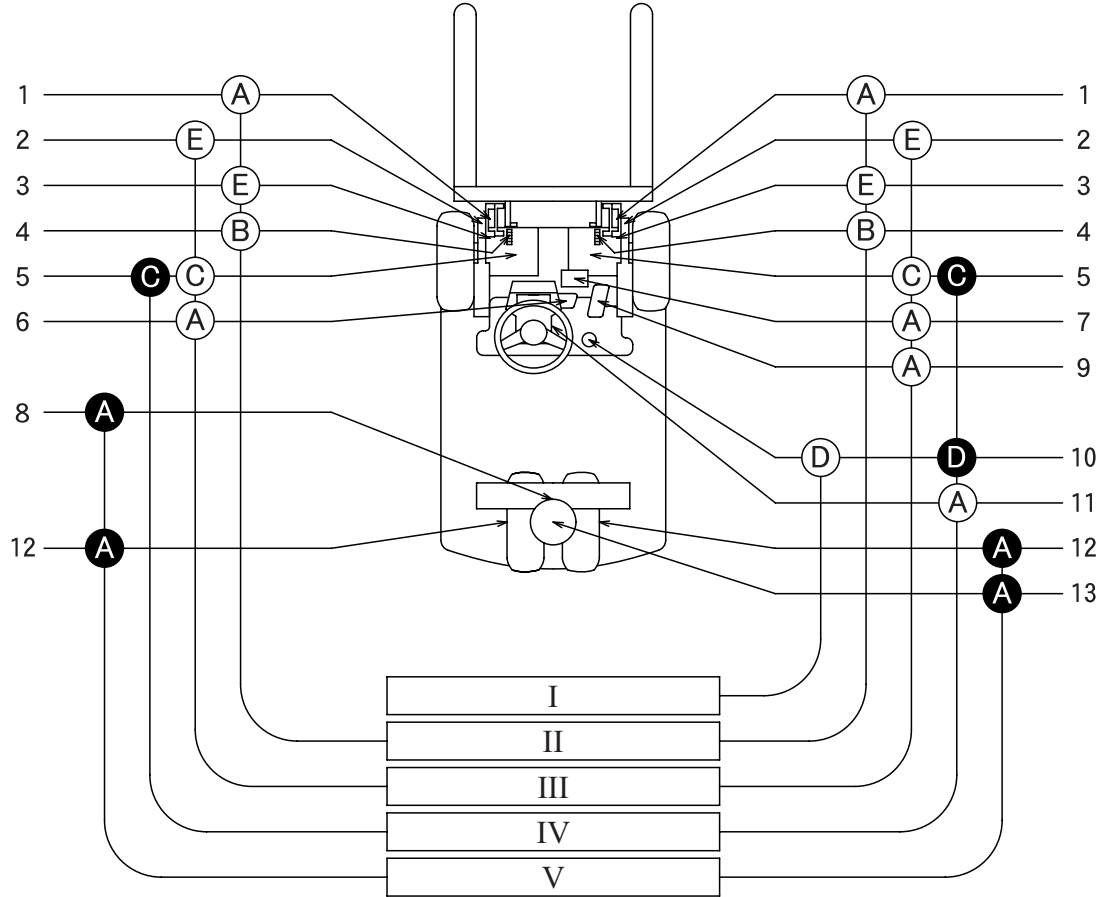

○: Inspection and addition

●: Replacement

A: MP grease

B: Motor oil

C: Gear oil (SAE 75W-80)

D: Hydraulic oil (ISO VG32)

E: Chassis grease special

I. Inspection every 8 hours (daily)

II. Inspection every 40 hours (weekly)

III. Inspection every 170 hours (monthly)

IV. Inspection every 1000 hours (6 monthly)

V. Inspection 2000 hours (annual)

1. Mast strip

2. Tilt cylinder front pin

3. Mast support bushing

4. Lift chain

5. Drive unit

6. Brake link

7. Oil control valve lever pin

8. Steering rack and pinion gear

9. Accelerator link

10. Oil tank

11. Tilt steering lock device

12. Rear wheel bearing

13. Rear axle bearing

PERIODIC MAINTENANCE

INSPECTION METHOD

I: Inspection · Repair or Replacement if required

M: Measurement · Repair or Adjustment if required

T: Retightening C: Cleaning L: Lubrication

*: For new vehicle *1: Flaw detector

Inspection timing		Every month	Every 3 months	Every 6 months	Every 12 months
		Every 170 hours	Every 500 hours	Every 1000 hours	Every 2000 hours
ELECTRICAL SYSTEM					
Motor	Rotation sound abnormality	I	←	←	←
	Looseness in the connecting parts	T	←	←	←
	Insulation resistance		M	←	←
Battery	Charging level (Display)	I	←	←	←
	Electrolyte level	I	←	←	←
	Electrolyte specific gravity	M	←	←	←
	Looseness in the connecting parts	I	←	←	←
	Abnormality in the upper portion of the battery and/or the case	I	←	←	←
	Insulation resistance		M	←	←
	Voltage measurement of each battery cell after charging				M
Charger	Timer function (Timer test)	I	←	←	←
	Looseness in the connecting parts	T	←	←	←
	HVR function voltage measurement				M
	Operating condition of the magnetic switch, contact contamination, roughness				I
Magnet switch	Contact looseness, damage, abrasion	I	←	←	←
	Operating condition, contamination and abrasion of the auxiliary contact	I	←	←	←
	Mounting condition of the arc shooter				I
	Operating condition and timing				I
	Looseness of the coil installation locations				I
	Mounting condition and looseness of the main circuit lead wire				I
Micro switch	Operating condition and timing	I	←	←	←
	Damage and looseness of installation locations	I	←	←	←
Direction lever	Operating condition, damage	I	←	←	←

Item		Inspection timing	Every month	Every 3 months	Every 6 months	Every 12 months
			Every 170 hours	Every 500 hours	Every 1000 hours	Every 2000 hours
Controller	Operating condition		I	←	←	←
	Interior contamination, damage		C	←	←	←
	Motor input voltage					M
Fuses	Looseness of the installation locations		I	←	←	←
Wiring (incl. charging cable)	Harness deterioration, damage and looseness of the clamp		I	←	←	←
	Looseness of the connections, taping condition		I	←	←	←
	Connecting condition and damage of the battery connector		I	←	←	←
POWER TRANSMISSION SYSTEM						
Drive unit	Oil leak		I	←	←	←
	Oil level		I	←	←	←
	Bolt or nut looseness					T
DRIVE SYSTEM						
Front axle	Damage and deformation					I
Rear axle	Damage and deformation					I
	Looseness of rear axle bearing					I
	Abnormal noise of rear axle bearing					I
Wheels	Tire pressure		M	←	←	←
	Tire crack, damage and abnormal wear		I	←	←	←
	Tire tread depth		M	←	←	←
	Metal piece, stone and other foreign matter on tire		I	←	←	←
	Loosening of wheel nut and bolt		T	←	←	←
	Rim, side ring and disc wheel damage		I	←	←	←
	Looseness and abnormal noise of front wheel bearing		I	←	←	←
	Looseness and abnormal noise of rear wheel bearing		I	←	←	←
STEERING SYSTEM						
Steering wheel	Play, loosening, looseness		I	←	←	←
	Function		I	←	←	←
Steering valve	Oil leak		I	←	←	←
	Looseness of the installation locations		T	←	←	←
Wheels for steering	Turning angle to left and right					I

Item		Inspection timing			
		Every month	Every 3 months	Every 6 months	Every 12 months
		Every 170 hours	Every 500 hours	Every 1000 hours	Every 2000 hours
Power steering	Oil leak	I	←	←	←
	Looseness of the installation locations	I	←	←	←
	Damage of power steering hose				I
BRAKING SYSTEM					
Brake pedal	Reserve	M	←	←	←
	Braking performance	I	←	←	←
Parking brake	Operating force and pull margin	I	←	←	←
	Braking performance	I	←	←	←
Rod and cable	Looseness and damage	I	←	←	←
	Operating condition	I	←	←	←
Disc brake	Clearance between disc and pad	M	←	←	←
	Wear of sliding portion and pad				I
	Disc wear and damage				I
	Looseness of the disc installation locations				I
	Operating condition				I
	Return spring fatigue				I
MATERIAL HANDLING SYSTEM					
Fork	Damage or wear of fork or stopper pin	I	←	←	←
	Fork deformation and wear	I	←	←	←
	Cracks at fork root and welded part of tooth				I*1
Mast and lift bracket	Deformation and damage of each part and crack at welded part	I	←	←	←
	Wear and damage of roller	I	←	←	←
	Mast and lift bracket looseness	I	←	←	←
	Wear and damage of mast support bushing				I
	Wear and damage of roller pin				I
	Wear and damage of mast strip	I	←	←	←
Chain and chain wheel	Chain lubrication	I	←	←	←
	Deformation, damage and slackness of chain	I	←	←	←
	Abnormality of chain anchor bolt	I	←	←	←
	Wear, damage and revolution of chain wheel	I	←	←	←
Various attachments	Abnormality and installation condition of each part	I	←	←	←

Item		Inspection timing			
		Every month	Every 3 months	Every 6 months	Every 12 months
		Every 170 hours	Every 500 hours	Every 1000 hours	Every 2000 hours
HYDRAULIC SYSTEM					
Cylinder	Looseness, deformation and damage of rod and rod end	I	←	←	←
	Cylinder operation	I	←	←	←
	Natural drop and natural forward tilt	M	←	←	←
	Oil leak and damage	I	←	←	←
	Wear and damage of pin and cylinder bearing	I	←	←	←
	Loosening and damage of cylinder mounting	T	←	←	←
	Lifting speed	M	←	←	←
	Uneven movement	I	←	←	←
Oil pump	Oil leak and abnormal sound	I	←	←	←
Hydraulic oil tank	Oil level and contamination	I	←	←	←
	Oil leak	I	←	←	←
	Tank and oil strainer cleaning			C	←
Hydraulic oil filter	Filter clogging				C
Control lever	Loose linkage	I	←	←	←
	Operation	I	←	←	←
Oil control valve	Oil leak	I	←	←	←
	Safety valve function	I	←	←	←
	Relief pressure measurement				M
Hydraulic hose and piping	Oil leakage, deformation and damage	I	←	←	←
	Looseness	T	←	←	←
SAFETY DEVICES, ETC.					
Head guard and backrest	Looseness of the installation locations	T	←	←	←
	Deformation, crack and damage	I	←	←	←
	Crack at welded portion	I	←	←	←
Lighting system	Function and installation condition	I	←	←	←
Direction indicator	Function and installation condition	I	←	←	←
Horn	Function and installation condition	I	←	←	←
Backup buzzer	Function and installation condition	I	←	←	←
Rear view mirror	Rear reflection status	I	←	←	←
	Dirt, damage	I	←	←	←

Item		Inspection timing			
		Every month	Every 3 months	Every 6 months	Every 12 months
		Every 170 hours	Every 500 hours	Every 1000 hours	Every 2000 hours
Instruments	Operation	I	←	←	←
Seat	Loosening and damage of mounting	I	←	←	←
	Seatbelt damage and function	I	←	←	←
	Deadman seat operation	I	←	←	←
Body	Damage and cracks in frame, cross members, etc.				I
	Bolts and nuts looseness				T
SAS	Functions	I	←	←	←
	Loosening and damage at sensor mounting portion	I	←	←	←
	Damage, deformation, oil leakage and loosened installation of functional parts	I	←	←	←
	Loosening and damage of wire harnesses	I	←	←	←
	Rusting and corrosion of load sensor				I
Others	Grease up	L	←	←	←

PERIODIC REPLACEMENT OF PARTS AND LUBRICANTS

●: Replacement

Item	Replacement cycle	Every month	Every 3 months	Every 6 months	Every 12 months
		Every 170 hours	Every 500 hours	Every 1000 hours	Every 2000 hours
Drive unit gear oil				●	←
Hydraulic oil				●	←
Hydraulic oil filter	● New vehicle initial replacement			●	←
Rear wheel bearing grease				●	←
Power steering hose					● Every 2 years
Power steering rubber parts					● Every 2 years
Hydraulic hose					● Every 2 years
Lift chain					● Every 3 years

BATTERY

	Page
BATTERY COMPARTMENT AND REQUIRED WEIGHT.....	1-2
SERVICE STANDARDS.....	1-3
DISPLAY	1-3
TROUBLESHOOTING	1-4
BATTERY ASSY	1-5
REMOVAL · INSTALLATION	1-5
INSPECTION	1-6
REPLACING BATTERY PLUG TERMINAL.....	1-9

BATTERY COMPARTMENT AND REQUIRED WEIGHT

When the battery is to be purchased locally, always adjust the weight to satisfy the minimum required weight as shown in the table below.

	Compartment dimension mm (in)			Minimum required bat- tery Weight (W/ case) kg (lb)	Remarks
	Depth X	Width Y	Height Z		
7FBE10-13	451 (17.8)	998 (39.3)	613 (24.1)	520 (1147)	
7FBE15-18	551 (21.7)	↑	↑	655 (1444)	
7FBE20	638 (25.1)	↑	↑	655 (1444)	

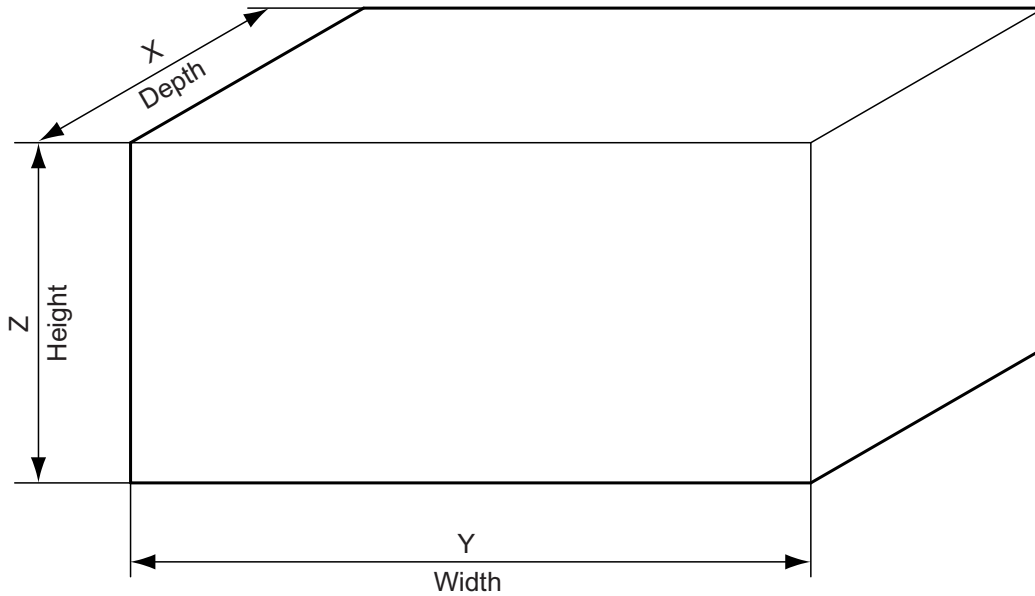

SERVICE STANDARDS

Specific gravity	1.280 [20°C (68°F)]
Specific gravity	1.150 [20°C (68°F)]
Discharge end voltage	42.5V
Electrolyte	Refined dilute sulfuric acid
Fluid to be added	Distilled water
Insulation resistance	1MΩ or more

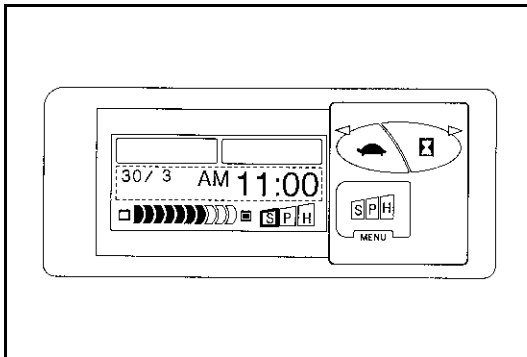

DISPLAY

Battery Charge Indicator

The battery charge indicator indicates 10 levels of battery charge on the LCD.

Battery discharged state %	LEDs									
	10 F	9	8	7	6	5	4	3	2	1 E
0 to 10 (exclusive)	○	○	○	○	○	○	○	○	○	○
10 to 20 (exclusive)	-	○	○	○	○	○	○	○	○	○
20 to 30 (exclusive)	-	-	○	○	○	○	○	○	○	○
30 to 40 (exclusive)	-	-	-	○	○	○	○	○	○	○
40 to 50 (exclusive)	-	-	-	-	○	○	○	○	○	○
50 to 60 (exclusive)	-	-	-	-	-	○	○	○	○	○
60 to 70 (exclusive)	-	-	-	-	-	-	○	○	○	○
70 to 80 (exclusive)	-	-	-	-	-	-	-	○	○	○
80 to 90 (exclusive)	-	-	-	-	-	-	-	-	○	○
90 to 100 (exclusive)	-	-	-	-	-	-	-	-	-	○
100 or more	-	-	-	-	-	-	-	-	-	-

Low Remaining Battery Charge Warning

When the battery charge becomes below the set level, the battery charge indicator blinks and the alarm will sound for five seconds after the key switch is set to the ON position.

Battery Overdischarge Warning

When the battery charge decreases further below the set level after the remaining battery charge warning, any attempt at traveling or material handling operation will cause all charge indicator segments to blink and the alarm to sound to warn the operator.

TROUBLESHOOTING

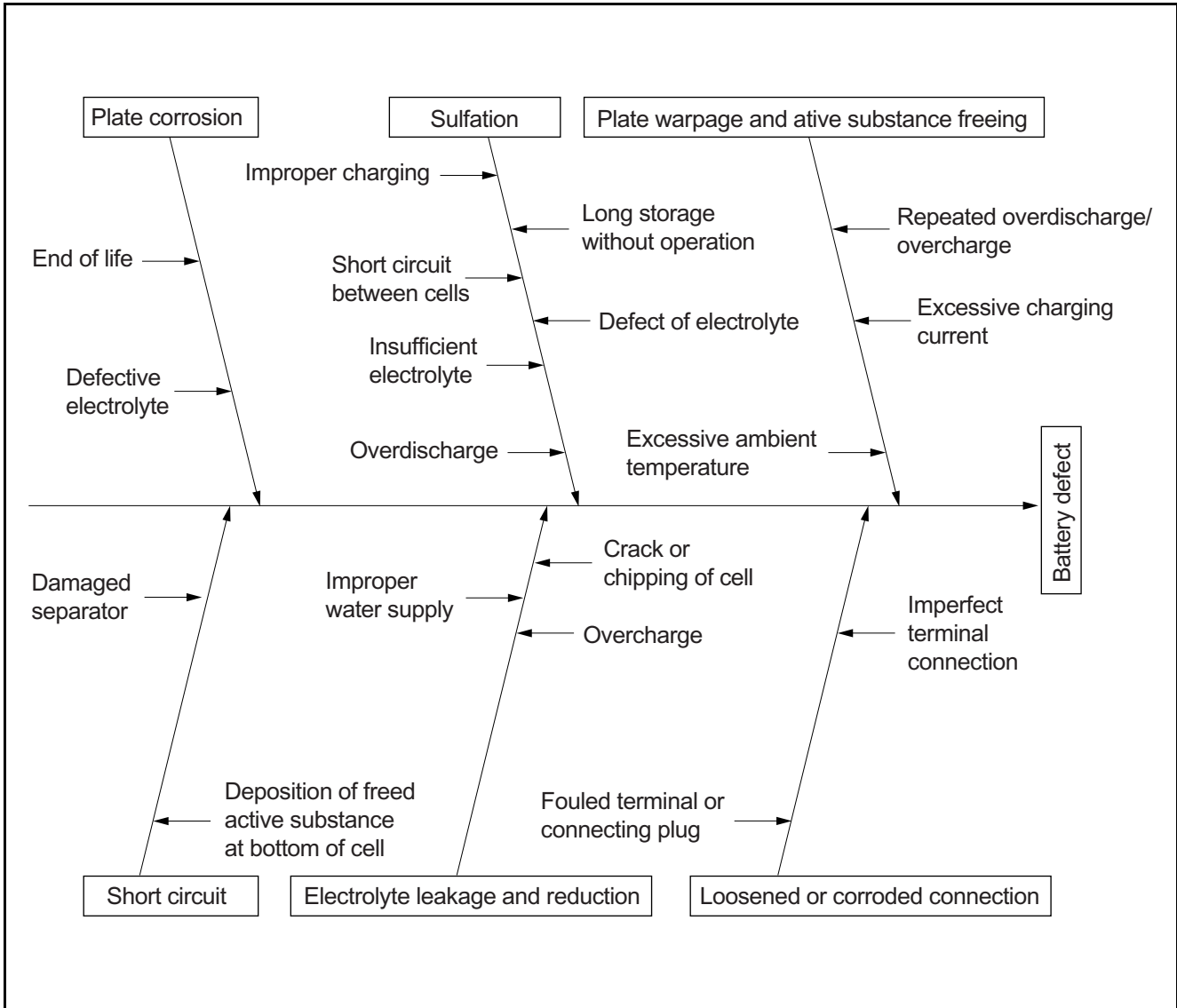

BATTERY ASSY REMOVAL · INSTALLATION

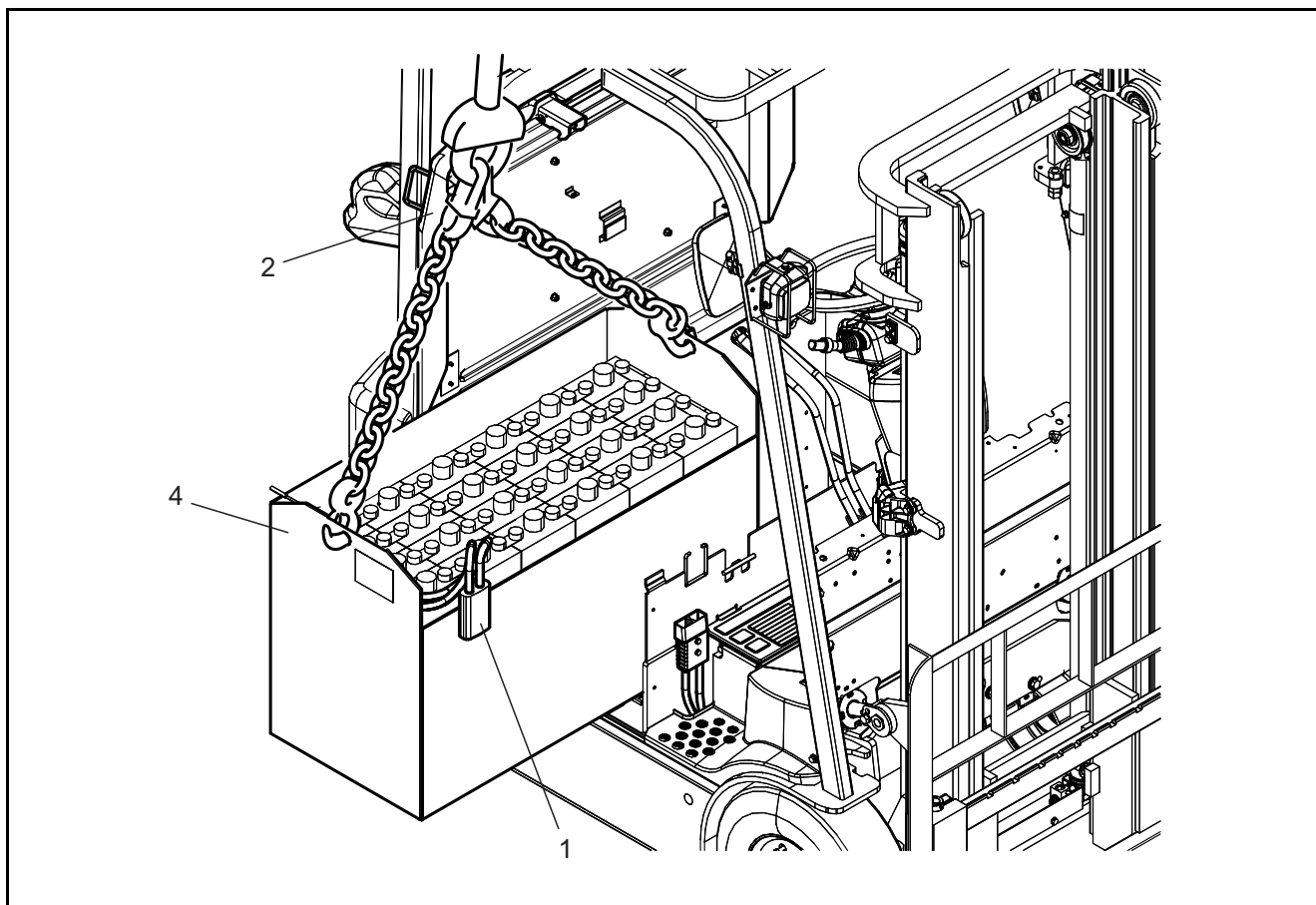

1

Removal Procedure

- 1 Disconnect the battery plug.
- 2 Open the seat stand.
- 3 Release the steering release lever.
- 4 Remove the battery ASSY. **[Point 1]**

Installation Procedure

The installation procedure is the reverse of the removal procedure.

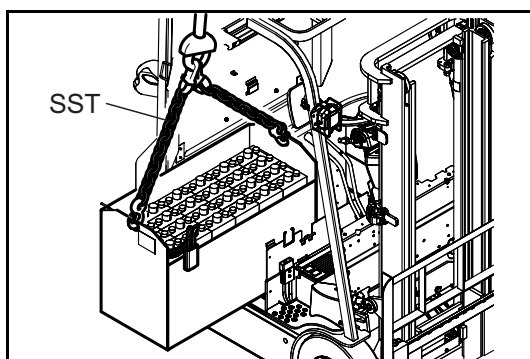

Point Operations

[POINT 1]

Removal · Installation:

SST 25009-13201-71

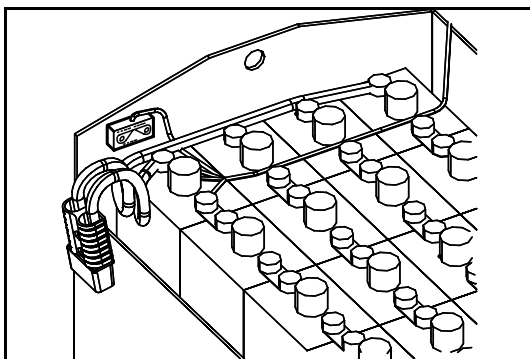
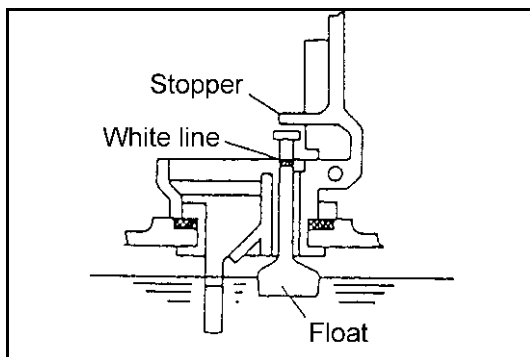

INSPECTION

1. Electrolyte level inspection
Open the cap, and if the white line on the red float has dropped, water should be added.
Add water until the white line appears.
Stop water addition when the white line appears, since addition is excessive when the tip end of the float comes into contact with the stopper.

As a level gauge is provided at the front of the battery case, the electrolyte level can generally be checked at a glance, but open the cap to check the level when making a periodic inspection.

The green light of the level gauge lights up to indicate activation of the level gauge sensor, and the red light flashes to indicate the necessity of adding water.

	Red light	Green light
Normal level	Off	On
Insufficient level	Blinking	On

Note:

Never change the installation location of the sensor.

Reference:

The consumption of electrolyte can be calculated by the following equation:

Consumption (cc) = 5 hour capacity × 0.0336 × number of cells × number of charges

Vehicle model	Number of cells	Battery capacity (AH/5HR)
7FBE10	24	280
7FBE13	↑	↑
7FBE15	↑	390
7FBE18	↑	↑
7FBE20	↑	↑

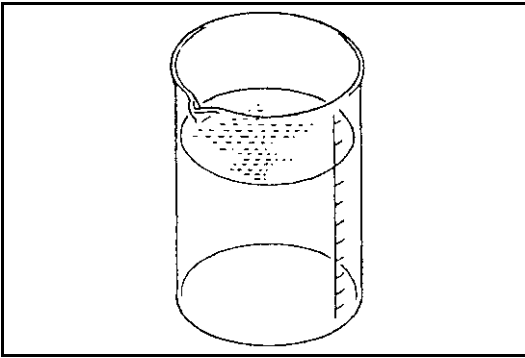

2. Electrolyte inspection
Electrolyte inspection Battery electrolyte is normal when it is transparent. Check turbidity when inspecting the specific gravity. If it cannot be checked clearly, put the electrolyte in a beaker for inspection.

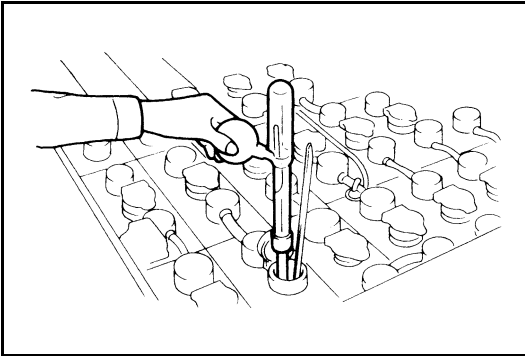

3. Battery electrolyte specific gravity inspection
Use a hydrometer to measure the specific gravity of the electrolyte.

Specific gravity upon complete charging

1.280[20°C(68°F)]

Specific gravity upon end of discharge

1.150[20°C(68°F)]

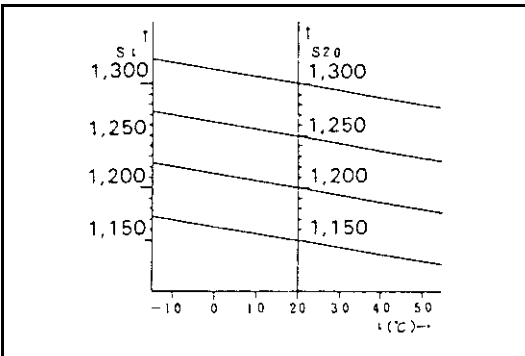

The specific gravity of the electrolyte at 20°C (68°F) is used.68

Equation for converting specific gravity

$$S_{20} = S_t + 0.0007 (t - 20)$$

S_{20} : Specific gravity at 20°C

S_t : Specific gravity at t°C

t : Electrolyte temperature upon measurement (°C)

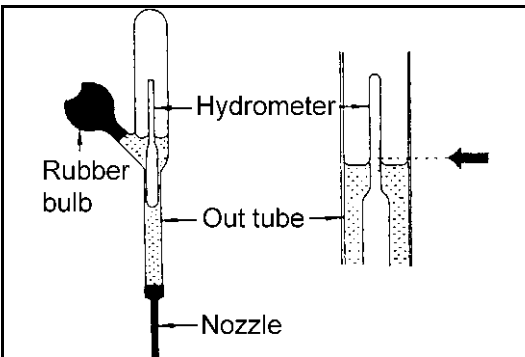

* How to use the hydrometer

- (1) Insert the nozzle of the hydrometer into the electrolyte port and allow the electrolyte to be sucked into its outer tube.
- (2) Let the hydrometer float correctly without contact with the outer tube, top or bottom, and read the scale at the highest point of the electrolyte surface as illustrated at left when the bubbles in the electrolyte disappear.
- (3) After the measurement, wash the inside and outside of the hydrometer well with clear water and store it after wiping water off with clean cloth.

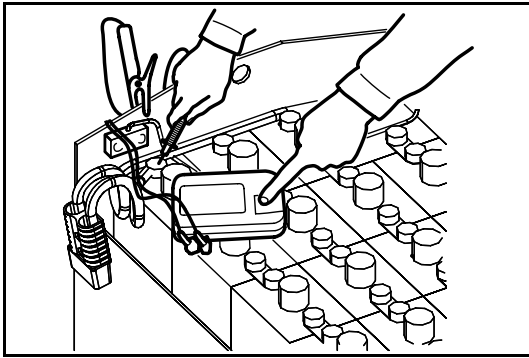

4. Insulation resistance inspection
 Measure the resistance between the battery and battery case with an insulation resistance meter (megohmmeter).
Insulation resistance 1 MΩ or more

Note:

When the insulation resistance is less than 1 MΩ, wash the battery with water after removing it from the vehicle. Fully dry the washed battery and measure the insulation resistance again. Install the battery on the vehicle after confirming that the insulation resistance is 1 MΩ or more.

* Battery control table

Prepare a control table for each battery to record and maintain the inspection results.

Inspection date and time	Inspected cell No.	Specific gravity	Electrolyte temperature	Added water quantity	Remarks	Inspector

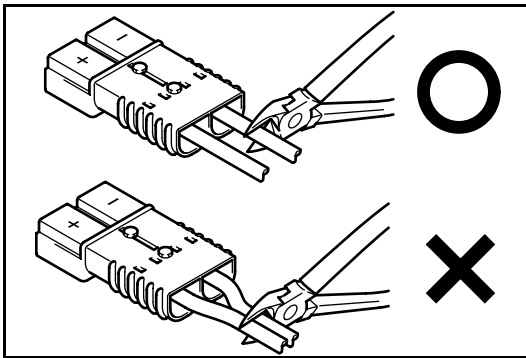

REPLACING BATTERY PLUG TERMINAL

1. Disconnect battery plug cable one by one.

Caution:

Never disconnect more than one cable at the same time. Fatal accident may result by short circuit.

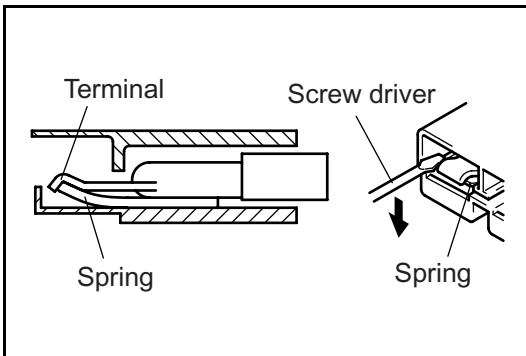

2. Insert a screwdriver from the terminal side, push down the spring at the bottom of the terminal and pull the cable to draw out the terminal.

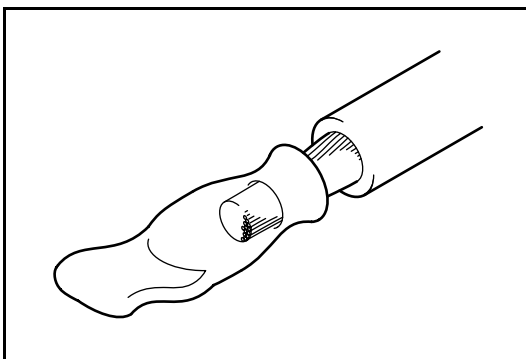

3. Peel off the tip of the cable for Approx. 30mm, solder sufficiently and insert it to the contact portion of the new terminal.

Note:

Be sure to prevent solder from pouring out and adhere to the contact surface of the terminal.

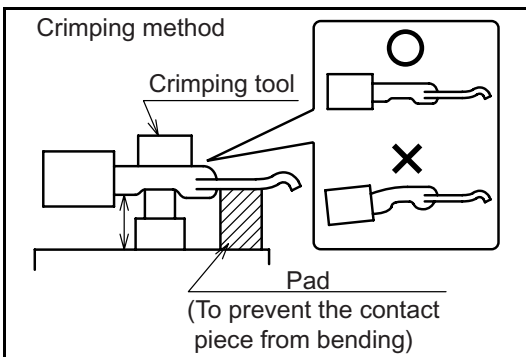

4. When crimping cables, never bend the terminal with a crimping tool.

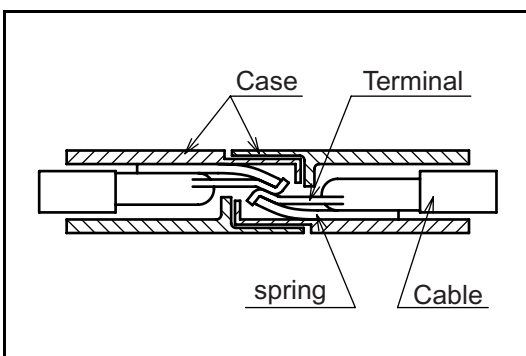

5. Insert the terminal to the battery plug. Check that the tip of the terminal goes over the tip of the spring and securely set in the position.

CHARGER (OPT)

	Page
GENERAL	2-2
ON-VEHICLE CHARGER	2-2
APPLICABLE CHARGER LIST	2-2
SPECIFICATIONS	2-3
COMPONENTS	2-4
WIRING DIAGRAM	2-5
TAP LAYOUT	2-5
BEFORE CHARGING	2-6
SWITCH BOX	2-7
MAGNETIC SWITCH ASSY	2-9
TRANSFORMER ASSY	2-11
TIMER TEST	2-15
TROUBLESHOOTING	2-16
OFF-VEHICLE CHARGER	2-26
APPLICABLE CHARGER LIST	2-26
GS	2-27
YUASA	2-43

GENERAL

A fully automatic microcomputer-controlled on-vehicle charger (STD) and a fully automatic microcomputer-controlled off-vehicle charger (OPT) are provided. The on-vehicle charger is not provided on cold storage models.

This manual explains mainly the on-vehicle charger.

ON-VEHICLE CHARGER

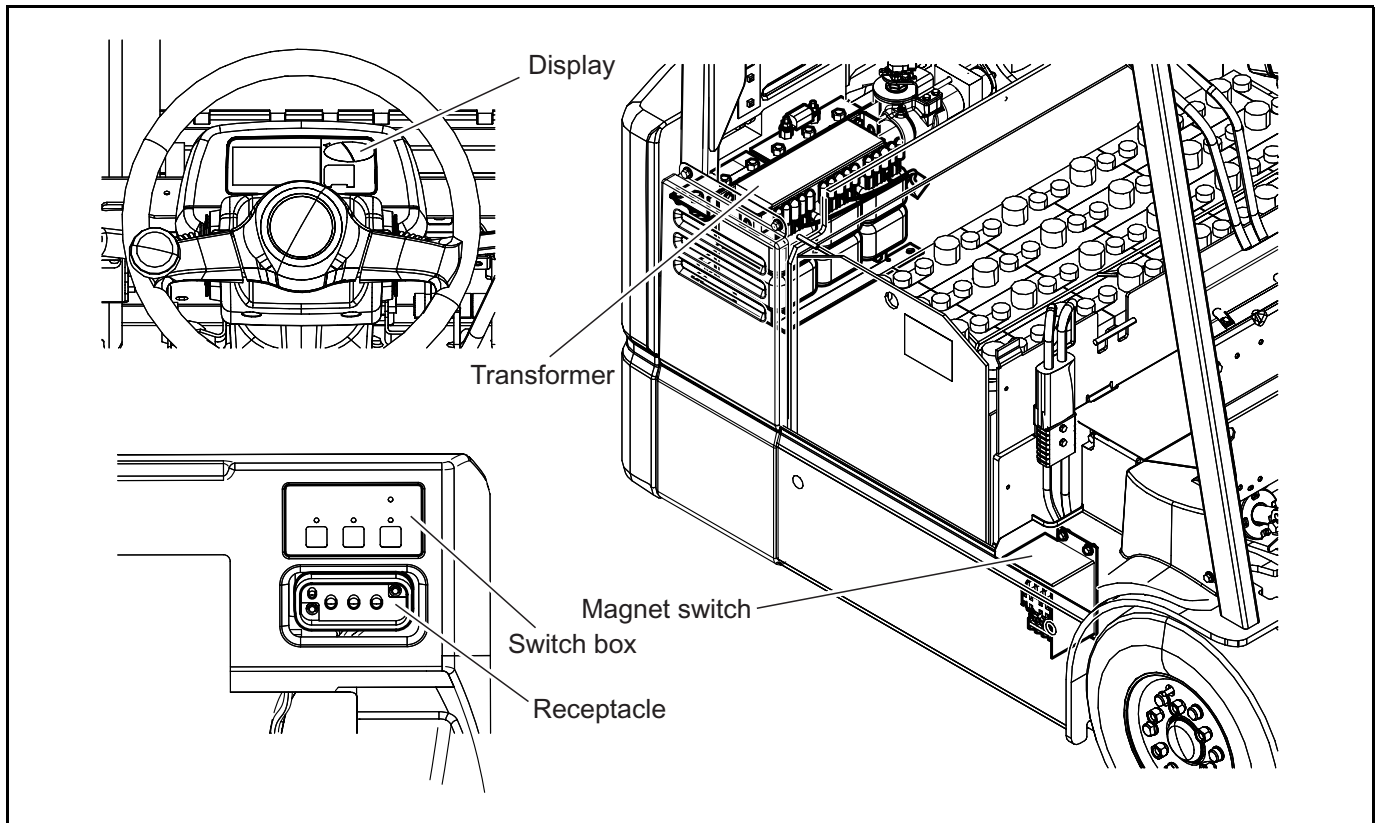

APPLICABLE CHARGER LIST

○:OPT

Transformer model	Power supply voltage	Transformer capacity (kVA) (50/60 Hz)	Battery voltage (V)	Applicable capacity (AH/5hr)	Power supply capacity (A) (50/60 Hz)	Applicable vehicle model				
						7 F	7 B	7 E	7 10	7 13
K47-227C048-405	200	4.0/3.9	48	280 to 312	15	○	○			
K47-230C048-413	↑	4.8/4.3	↑	365 to 390	15	○	○	○	○	○
K47-260C048-409	↑	7.1/7.0	↑	476 to 645	30			○	○	○



Download the full PDF manual instantly.

Our customer service e-mail:

aservicemanualpdf@yahoo.com