

WA65-6

WA70-6

WA80-6

WA90-6

WA100M-6

WHEEL LOADER

Model:

WA65-6
WA70-6
WA80-6
WA90-6
WA100M-6

Serial number:

H60051 AND UP
H60051 AND UP
H60051 AND UP
H00051 AND UP
H60051 AND UP

- This shop manual may contain attachments and optional equipment that are not available in your area. Please consult your local KOMATSU distributor for those items you may require.
- Materials and specifications are subject to change without notice.
- The Wheel Loaders WA65-6 and WA70-6 are equipped with the engine 4D95LWE-5.
The Wheel Loaders WA80-6 is equipped with the engine S4D95LWE-5.
The Wheel Loaders WA90-6 and WA100M-6 are equipped with the engine SAA4D95LE-5.
- For details of this engine see Engine Manual: WA65-WA80-6 SEN04408-00
WA90-6 and WA100M-6 SEN04357-00

Contents

Contents	TOC
List of revised pages	00-1

Safety

Safety notice	00-2
Preparations for work	00-3
Tipping up the driver's cab	00-4
Tipping down the driver's cab	00-6
Precautions during work	00-8
Hydraulic system	00-9
Foreword	00-10
How to read the shop manual	00-11
Volumes	00-11
Distribution and updating	00-11
Filing method	00-11
Symbols	00-12
Hoisting instructions	00-13
Wire ropes	00-13

General

Dimensions, weights and operating data	01-2
Specifications	01-4
WA65-6 – Specifications	01-4
WA70-6 – Specifications	01-5
WA80-6 – Specifications	01-6
WA90-6 – Specifications	01-7
WA100M-6 – Specifications	01-8
Weight tables	01-9
WA65-6 – Weight table	01-9
WA70-6 – Weight table	01-9
WA80-6 – Weight table	01-10
WA90-6 – Weight table	01-10
WA100M-6 – Weight table	01-11
Lubricants and operating mediums	01-12
WA65-6, WA70-6 – Lubricants and operating mediums	01-12
WA80-6 – Lubricants and operating mediums	01-13
WA90-6 – Lubricants and operating mediums	01-14
WA100M-6 – Lubricants and operating mediums	01-15
Basic procedures of maintenance	01-16
Oil	01-16
Fuel	01-16
Coolant	01-17
Grease	01-17
Storing oil and fuel	01-17
Filters	01-18
Biodegradable hydraulic oils and lubricants	01-18
Outline of electric system	01-18
Torque list – Screws and nuts	01-19

Structure and Function

Powertrain	10-5
Closed circuit	10-6
Hydraulic drive system	10-7
WA65-6, WA70-6 – Hydraulic drive system – 20 km/h	10-7
WA80-6 – Hydraulic drive system – 20 km/h and 30 km/h	10-8
WA90-6, WA100M-6 – Hydraulic drive system – 20 km/h and 30 km/h	10-9
Variable displacement pump (HST pump)	10-10
Regulating valve (DA valve)	10-13
WA65-6, WA70-6, WA80-6 - Charge pump pressure relief valve - 20km/h.	10-14
WA80-6 ,WA90-6, 100M-6 - Charge pump pressure relief valve - 30km/h	10-14
Control cylinder	10-15
4/3 Way valve with direction control solenoids	10-16
Pressure cut-off valve	10-17
Safety & charge valve	10-18
Towing	10-19
Variable displacement motor (HST motor with HA Control)	10-20
Hydraulic diagram HST motor A6VM80 (or 160) HA1R1	10-22
Directional shuttle valve.	10-23
Auto inch valve diagram (option)	10-23
HST motor with DA Control	10-24
Hydraulic diagram HST Motor A6VM107(160)DA2	10-25
Drive shaft	10-26
Front axle – Mounting	10-27
WA65-6, WA70-6 – Front axle mounting	10-27
WA80-6, WA90-6, WA100M-6 – Front axle mounting	10-27
Rear axle – Mounting	10-28
Front axle	10-29
WA65-6, WA70-6 – Front axle with outer disc brake as service brake and parking brake	10-29
WA80-6 – Front axle with inner disc brake as service brake and outer disc brake as parking brake	10-30
WA90-6, WA100M-6 – Front axle with inner disc brake as service brake and outer disc brake as parking brake	10-31
Rear axle with transfer box	10-32
WA65-6, WA70-6, WA80-6 – Rear axle with transfer box	10-32
WA90-6, WA100M-6 – Rear axle with transfer box	10-33
Transfer box TB172	10-34
Limited slip differential	10-36
Limited slip differential – Locking value 25%.	10-36
Locking differential	10-38
Locking differential – Locking value 100%.	10-38
Wheel hub – Front axle and rear axle	10-40
Service and parking brake – Front axle	10-42
WA65-6, WA70-6 – Service and parking brake	10-42
WA80-6, WA90-6, WA100M-6 – Service brake	10-44
WA80-6, WA90-6, WA100M-6 – Parking brake	10-45

Service and parking brake circuit	10-46
WA65-6, WA70-6 – Service and parking brake circuit	10-46
WA80-6 – Service and parking brake circuit	10-47
WA90-6, WA100M-6 – Service and parking brake circuit	10-48
Service brake assembly	10-49
WA65-6, WA70-6 – Service brake assembly	10-49
WA80-6 – Service brake assembly	10-50
WA90-6, WA100M-6 – Service brake assembly	10-51
Main-brake valve	10-52
WA65-6, WA70-6 – Main-brake valve	10-52
WA80, WA90-6, WA100M-6 – Main-brake valve	10-53
Steering articulation joint	10-54
Steering system	10-56
WA65-6, WA70-6 – Hydraulic circuit diagram of steering system	10-56
WA80-6 – Hydraulic circuit diagram of steering system	10-58
WA90-6, WA100M-6 – Hydraulic circuit diagram of steering system	10-60
Priority valve	10-62
Orbit-roll-valve	10-63
Steering relief valve	10-64
Work equipment hydraulic	10-66
WA65-6, WA70-6 – Travel, steering and work hydraulics	10-66
WA80-6 – Travel, steering and work hydraulics	10-68
WA90-6, WA100M-6 – Travel, steering and work hydraulics	10-70
PPC-Valve WA90-6, WA100M-6	10-72
Operation of PPC-valve	10-73
Servo pressure regulating valve	10-74
Emergency Lowering System	10-74
Main control valve	10-75
Main control valve WA65-6, WA70-6, WA80-6	10-75
Main control valve WA90-6, WA100M-6	10-76
Lift cylinder	10-77
WA65-6, WA70-6 – Lift cylinder	10-77
WA80-6 – Lift cylinder	10-78
WA90-6 – Lift cylinder	10-79
WA100M-6 – Lift cylinder	10-80
Dump cylinder	10-81
WA65-6, WA70-6 – Dump cylinder	10-81
WA80-6 – Dump cylinder	10-82
WA90-6 – Dump cylinder	10-83
WA100M-6 – Dump cylinder	10-84
Steering cylinder	10-85
WA65-6, WA70-6 – Steering cylinder	10-85
WA80-6 – Steering cylinder	10-86
WA90-6, WA100M-6 – Steering cylinder	10-87
Loader Linkage with quick-coupler	10-88
WA65-6, WA70-6 – Loader Linkage with quick-coupler	10-88
WA80-6, WA90-6, WA100M-6 – Loader Linkage with quick-coupler	10-89

Quick-coupler	10-90
WA65-6, WA70-6 – Quick-coupler	10-90
WA80-6 – Quick-coupler	10-91
WA90-6, WA100M-6 – Quick-coupler	10-91.1
Monitor display	10-92
WA65-6, WA70-6, WA80-6 – Monitor display	10-92
WA90-6, WA100M-6 – Monitor display	10-94
Special monitor functions	10-96
Monitor panel adjustment	10-97
Adjustment switches	10-97
Adjustment table	10-98
WA65-6, WA70-6 Tire table	10-100
WA80-6 Tire table	10-101
WA90-6 Tire table	10-102
WA100M-6 Tire table	10-103
Reading error codes WA90-6, WA100M-6	10-104
Trouble Codes and Cummins Fault Codes	10-105
Sensors	10-113
Engine oil pressure sensor	10-113
Fuel level sensor	10-114
Engine coolant temperature sensor	10-115
Brake oil reservoir sensor	10-116
Pre-heater	10-118
WA65-6, WA70-6, WA80-6 – Glow plugs	10-118
WA90-6, WA100M-6 – Ribbon heater	10-119
Engine stop / start / preheating circuit	10-120
WA65-6, WA70-6, WA80-6	10-120
WA90-6, WA100M-6	10-122
Electrical fuses and relays	10-124
Fuses	10-124
Relays	10-125
Engine room	10-126
Diagrams	10-127
Wiring diagrams	10-127
Hydraulic circuit diagram	10-127
Air conditioner (option)	10-128
Introduction	10-128
Function	10-129
The coolant circuit	10-129
The condenser	10-131
The vaporizer	10-132
The filter dryer	10-133
Installation of air conditioner	10-134
Safety when handling coolants	10-135
Operating the air conditioner	10-137
Maintenance of the air conditioner	10-138
Regular maintenance	10-139
Instructions for filling	10-141
Exchange of magnetic clutch	10-144
Exchange of compressor	10-145
Troubleshooting	10-147

Testing and Adjusting

Standard value table for engine	20-4
WA65-6, WA70-6, WA80-6 - Standard value table for engine	20-4
WA90-6, WA100M-6 - Standard value table for engine	20-5
Standard value table for chassis	20-6
WA65-6 - Standard value table for chassis	20-6
WA70-6 - Standard value table for chassis	20-8
WA80-6 - Standard value table for chassis	20-10
WA90-6 - Standard value table for chassis	20-12
WA100M-6 - Standard value table for chassis	20-14
Standard value table for electrical parts	20-16
Test certificate	20-17
WA65-6 - Test certificate	20-17
WA70-6 - Test certificate	20-18
WA80-6 - Test certificate	20-19
WA90-6 - Test certificate	20-20
WA100M-6 - Test certificate	20-21
Valve lash clearance	20-22
WA65-6, WA70-6, WA80-6 - Valve lash clearance	20-22
WA90-6, WA100M-6 - Valve lash clearance	20-24
Engine compression test	20-26
WA65-6, WA70-6, WA80-6 - Engine compression test	20-26
WA90-6, WA100M-6 - Engine compression test	20-27
Fuel system	20-31
WA65-5, WA70-6, WA80-6 - Testing and adjusting fuel injection timing	20-34
WA90-6, WA100M-6 - Testing fuel pressure	20-38
WA90-6, WA100M-6 - Bleeding air from fuel circuit	20-43
WA90-6, WA100M-6 - Testing fuel system for leakage	20-45
V-belt tension	20-46
Engine RPM	20-47
Testing travel speed	20-48
Engine stall torque RPM	20-49
Engine stall torque RPM, test with the hydrostatic drive	20-50
Engine stall torque RPM, test with hydrostatic drive and working hydraulics	20-51
Feed pump (and servo oil pressure)	20-52
WA90-6 and WA100M-6	20-52
Hydraulic pressure cut-off	20-53
Working hydraulic pressure	20-55
Steering oil pressure	20-56
Testing	20-56
Adjusting	20-57
Operating time for steering wheel	20-58
Operating force of steering wheel	20-59
Disc brake (foot brake)	20-60
WA80-6, WA90-6, WA100M-6 - Disc brake (foot brake)	20-60
Brake	20-61
WA65-6, WA70-6 - Brake	20-61

Main brake valve – basic adjustment	20-62
WA65-6, WA70-6	20-62
WA80-6, WA90-6, WA100M-6	20-62
Brake efficiency	20-63
Measuring the stopping distance	20-63
Parking brake efficiency	20-64
Bleeding/ filling up the brake circuit	20-65
WA65-6, WA70-6 - Bleeding/ filling up the brake circuit	20-65
Ventilation / filling up the brake circuit	20-67
WA80-6, WA90-6, WA100M-6 - Ventilation / filling up the brake circuit	20-67
Cabin - adjustment	20-68

Disassembly and Assembly

Comments	30-5
Starter assembly	30-6
Removal of starter assembly	30-6
Installation of starter assembly	30-7
Alternator assembly	30-8
Removal of alternator assembly	30-8
Installation of alternator assembly	30-9
Radiator assembly	30-10
Removal of radiator assembly	30-10
Installation of radiator assembly	30-14
Fan assembly	30-15
Removal of fan assembly	30-15
Installation of fan assembly	30-16
Water pump assembly	30-17
Removal of water pump assembly	30-17
Installation of water pump assembly	30-19
Fuel tank assembly	30-20
Removal and installation of fuel tank assembly	30-20
Installation	30-20
Engine cover assembly	30-21
Removal of engine cover assembly	30-21
Installation of engine cover assembly	30-22
Engine cover support assembly	30-23
Removal of engine cover support assembly	30-23
Installation of engine cover support assembly	30-24
Engine assembly	30-25
Removal of engine assembly	30-25
Installation of engine assembly	30-32
Clutch assembly	30-34
Removal of clutch assembly	30-34
Installation of clutch assembly	30-35
Main brake valve assembly	30-36
Removal of main brake valve assembly	30-36
Installation of main brake valve assembly	30-37

Priority valve assembly	30-38
Removal of priority valve assembly	30-38
Installation of priority valve assembly	30-39
Orbit-roll-valve assembly	30-40
Removal of orbit-roll-valve assembly	30-40
Installation of orbit-roll-valve assembly	30-42
Counterweight assembly	30-43
Removal of counterweight assembly	30-43
Installation of counterweight assembly	30-45
Main control valve assembly - WA65-6, WA70-6, WA80-6.	30-46
Removal of control valve assembly	30-46
Installation of main control valve assembly	30-48
Main control valve assembly - WA90-6, WA100M-6.	30-49
Removal of main control valve assembly	30-49
Installation of main control valve assembly	30-50
Pilot valve assembly WA90-6, WA100M-6.	30-51
Removal of pilot valve assembly	30-51
Installation of pilot valve assembly	30-53
Monitor assembly	30-54
Removal of monitor assembly	30-54
Installation of monitor assembly	30-55
Articulated joint assembly	30-56
Removal of articulated joint assembly	30-56
Installation of articulated joint assembly	30-57
Variable motor assembly	30-58
Removal of variable motor assembly	30-58
Installation of variable motor assembly	30-60
Rear axle assembly	30-61
Removal of rear axle assembly	30-61
Installation of rear axle assembly	30-63
Front axle assembly	30-64
Removal of front axle assembly	30-64
Installation of front axle assembly	30-66
Front axle	30-67
Brake disc group	30-67
Disassembly	30-67
Assembly	30-69
Brake caliper	30-71
Hydraulic principle of operation	30-71
Differential position	30-72
Mechanical principle of operation	30-72
Caliper removal	30-72
Disassembly (calliper removed)	30-73
Disassembly	30-73
Assembly	30-75
Caliper reassembly	30-77
Replacement of guide protective covers	30-77
Pad replacement	30-78

Brake group - wheel shaft	30-79
Disassembly	30-79
Assembly	30-82
Rear axle	30-85
Trunnions group and flange	30-85
Disassembly	30-85
Assembly	30-86
Epicyclic reduction gear group	30-88
Disassembly	30-88
Assembly	30-89
Wheel hub	30-90
Disassembly	30-90
Assembly	30-92
Wheel shaft - WA65-6, WA70-6	30-94
Disassembly	30-94
Assembly	30-95
Wheel shaft - WA80-6, WA90-6, WA100M-6	30-97
Disassembly	30-97
Assembly	30-98
Differential support group	30-100
Disassembly	30-100
Assembly	30-101
Bevel gear marking test	30-105
Differential locking group	30-106
Disassembly	30-106
Assembly	30-107
Differential group (100% Differential Lock)	30-108
Disassembly	30-108
Assembly	30-109
Differential group (LSD 25%)	30-110
Disassembly	30-110
Assembly	30-111
Pinion group	30-112
Disassembly	30-112
Assembly	30-113
Transmission box	30-116
Disassembly	30-116
Assembly	30-121
Variable displacement pump assembly	30-126
Removal of variable displacement pump assembly	30-126
Installation of variable displacement pump assembly	30-128
Hydraulic pump assemblies	30-129
Removal of the two hydraulic pump assemblies	30-129
Installation of hydraulic pump assembly	30-130
Turbocharger assembly - WA80-6, WA90-6, WA100M-6	30-131
Removal of the turbocharger	30-131
Installation of the turbocharger	30-131

Quick coupler assembly	30-132
Removal of quick coupler assembly	30-132
Installation of quick coupler assembly	30-133
Steering cylinder assembly	30-134
Removal of steering cylinder assembly	30-134
Installation of steering cylinder assembly	30-135
Lift cylinder assembly	30-136
Removal of lift cylinder assembly	30-136
Installation of lift cylinder assembly	30-137
Dump cylinder assembly	30-138
Removal of dump cylinder assembly	30-138
Installation of dump cylinder assembly	30-139
Replacing windows in driver's cab	30-140
Stuck glass	30-140
Installation	30-142
Door and side windows	30-143
Door window assembly	30-143
Side window assembly	30-143

Diagrams

Hydraulic circuit diagram – WA65-6, WA70-6	90-3
Hydraulic circuit diagram – WA80-6	90-5
Hydraulic circuit diagram – WA90-6, WA100M-6	90-7
Wiring diagram 1/9 – WA90-6, WA100M-6	90-9
Wiring diagram 2/9 – WA65-6, WA70-6, WA80-6, WA90-6, WA100M-6	90-11
Wiring diagram 3/9 – WA65-6, WA70-6, WA80-6, WA90-6, WA100M-6	90-13
Wiring diagram 4/9 – WA65-6, WA70-6, WA80-6, WA90-6, WA100M-6	90-15
Wiring diagram 5/9 – WA65-6, WA70-6, WA80-6, WA90-6, WA100M-6	90-17
Wiring diagram 6/9 – WA65-6, WA70-6, WA80-6, WA90-6, WA100M-6	90-19
Wiring diagram 7/9 – WA65-6, WA70-6, WA80-6, WA90-6, WA100M-6	90-21
Wiring diagram 8/9 – WA90-6, WA100M-6	90-23
Wiring diagram 9/9 – WA65-6, WA70-6, WA80-6-6	90-25

00 SAFETY

Safety notice	00-2
Preparations for work	00-3
Tipping up the driver's cab	00-4
Tipping down the driver's cab	00-6
Precautions during work	00-8
Hydraulic system	00-9
Foreword	00-10
How to read the shop manual	00-11
Volumes	00-11
Distribution and updating	00-11
Filing method	00-11
Symbols	00-12
Hoisting instructions	00-13
Wire ropes	00-13

List of revised pages

The affected pages are indicated by the use of the following marks. It is requested that necessary actions be taken to these pages according to the table below.	Mark	Indication	Action required
	○	Page to be newly added	Add
	●	Page to be replaced	Replace
	()	Page to be deleted	Discard
NOTE Pages having no marks are those previously revised or made additions.			

Safety notice



Important Safety Notice

Proper service and repair is extremely important for safe machine operation. Some of the described service and repair techniques require the use of tools specially designed by Komatsu for the specific purpose.

To prevent injury to workers, the symbol  is used to mark safety precautions in this manual. The cautions accompanying these symbols must always be followed carefully. If any dangerous situation arises or may possibly arise, first consider safety, and take the necessary actions to deal with the situation.



General Precautions

Mistakes in operation are extremely dangerous. Read the **OPERATION AND MAINTENANCE MANUAL** carefully before operating the machine! Always follow the safety rules valid in your country carefully!

1. Before carrying out any greasing or repairs, read all the precautions given on the decals which are fixed to the machine.
2. When carrying out any operation, always wear safety shoes and helmet. Do not wear loose work clothes, or clothes with buttons missing.
 - Always wear safety glasses when hitting parts with a hammer.
 - Always wear safety glasses when grinding parts with a grinder, etc.
3. If welding repairs are needed, always have a trained, experienced welder carry out the work. When carrying out welding work, always wear welding gloves, apron, glasses, cap and other clothes suited for welding work.
4. When carrying out any operation with two or more workers, always agree on the operating procedure before starting. Always inform your fellow workers before starting any step of the operation. Before starting work, hang **UNDER REPAIR** signs on the controls in the operator's compartment.

5. Keep all tools in good condition and learn the correct way to use them.
6. Decide a place in the repair workshop to keep tools and removed parts. Always keep the tools and parts in their correct places. Always keep the work area clean and make sure that there is no dirt or oil on the floor. Never smoke while working. Smoke only in the areas provided for smoking.

Preparations for work

1. Before adding oil or making any repairs, park the machine on hard, level ground, and block the wheels or tracks to prevent the machine from moving.
2. Before starting work, lower blade, ripper, bucket or any other work equipment to the ground and install the safety bar on the frame. If this is not possible, insert the safety pin or use blocks to prevent the work equipment from falling. In addition, be sure to lock all the control levers and hang warning signs on them.
3. When disassembling or assembling, support the machine with blocks, jacks or stands before starting work.
4. Remove all mud and oil from the steps or other places used to get on and off the machine. Always use the handrails, ladders or steps when getting on or off the machine. Never jump on or off the machine. If it is impossible to use the handrails, ladders or steps, use a stand to provide safe footing.

Tipping up the driver's cab

1. Park the machine on solid, level ground.
2. Lower the work unit to the ground and switch off the engine.
3. Close the cab door.
4. Use the locking bolt to secure the articulated steering.

NOTE

The machine has to be positioned straight and the articulated steering has to be secured with the locking bolt! If the driver's cab is tipped up while the machine is bent, the front frame can cause damage to the windscreen!

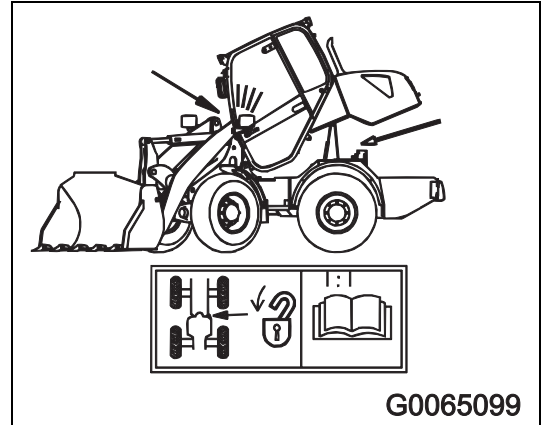

5. Open the bonnet.
6. Remove locking pins (1) and loosen the retaining screws (2) for the cab on both sides.

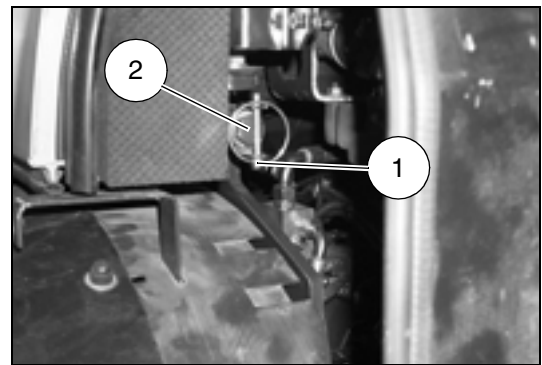

7. Take the hand pump lever from its holder on the radiator (3) and insert it into the receptacle of the pump (4).

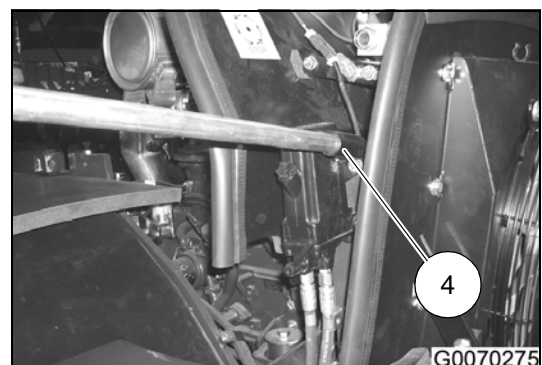
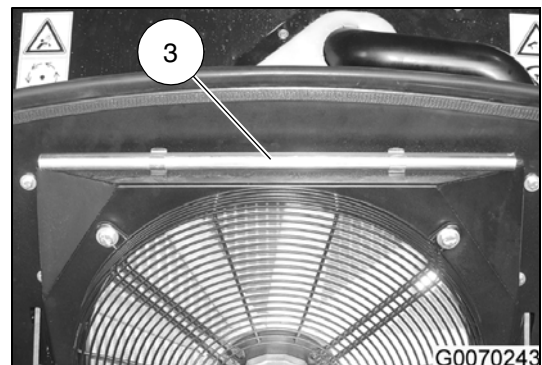

8. Set the lever at the pump to "pump up" and pump the cab upward until it reaches the limit stop.

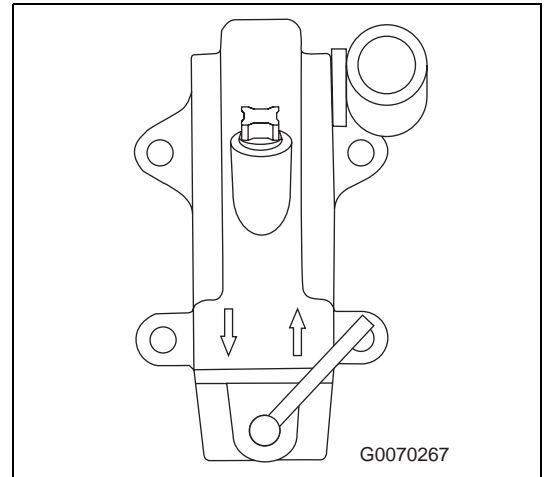

9. Fold out the safety rod on the right side over the retaining pin.

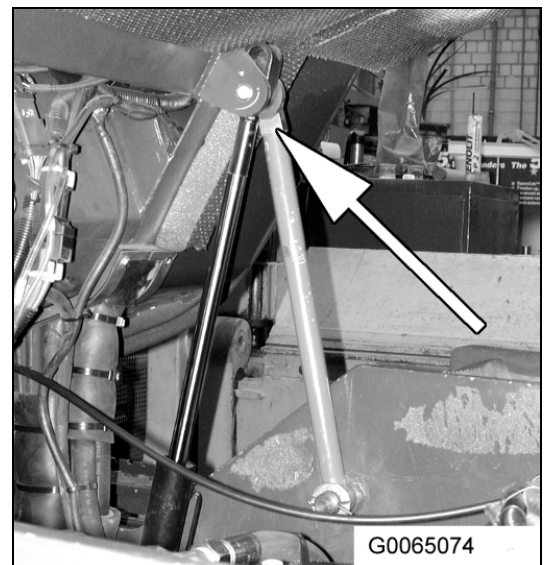

10. Set the lever at the pump to "pump down" and pump the cab downward until the safety rod is secure against the right side of the cab floor.

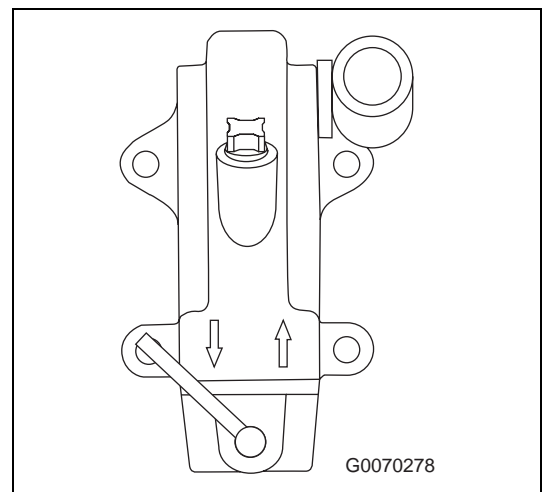

11. Remove the lever from the pump.

Tipping down the driver's cab

1. Insert the lever into the pump. Set the lever at the pump to "pump up" and pump the cab upward until it reaches the limit stop..

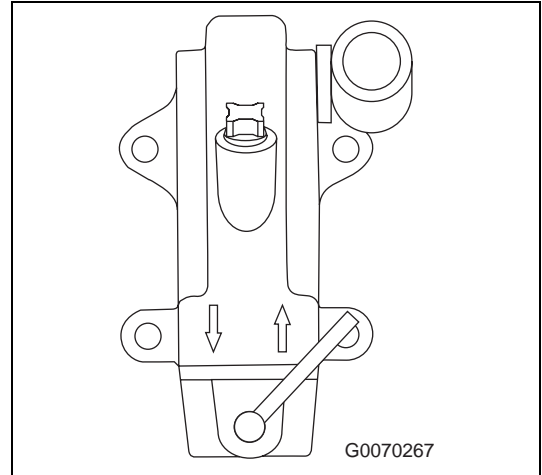

2. Fold down the safety rod on the right side and fasten it in this position (arrow).

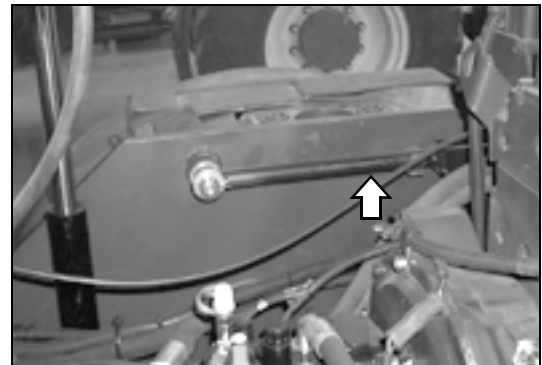

3. Set the lever to "pump down" and pump the cab downward until the cylinder is entirely retracted (the resistance at the lever increases markedly).

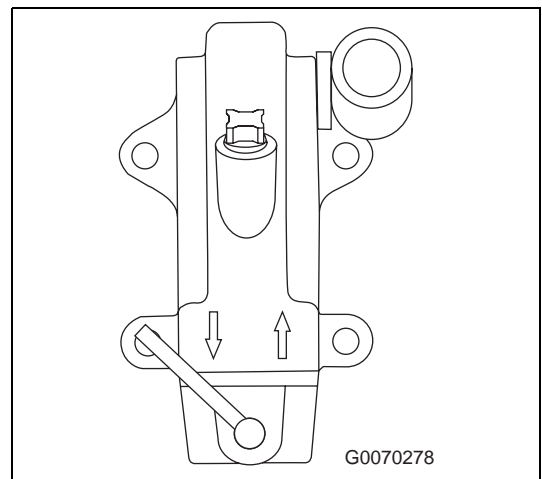

4. Remove the lever from the pump and fasten it to the radiator.

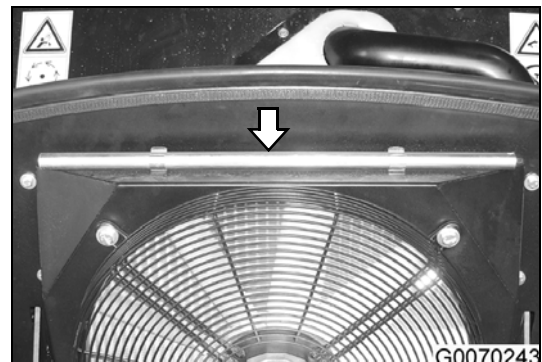

5. Insert and tighten the retaining screws (2) for the cab (1 left, 1 right). Secure the screws with the retaining pins (1).

Torque = 500 Nm

6. Close the bonnet.

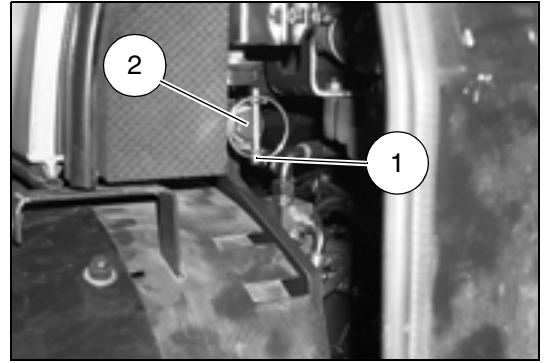

Precautions during work

1. When measuring hydraulic pressure, check that the measuring tool is correctly assembled before taking any measurements.
2. When removing the oil filler cap, drain plug or hydraulic pressure measuring plugs, loosen them slowly to prevent the oil from spurting out.

Before disconnecting or removing components of the oil, water or air circuits, first remove the pressure completely from the circuit.

3. The water and oil in the circuits are hot when the engine is stopped, so be careful not to get burned.

Wait for the oil and water to cool before carrying out any work on the oil or water circuits.

4. Before starting work, remove the leads from the battery. Always remove the lead from the negative (-) terminal first.
5. When raising heavy components, use a hoist or crane.

Check that the wire rope, chains and hooks are free from damage.

Always use lifting equipment which has ample capacity.

Install the lifting equipment at the correct places. Use a hoist or crane and operate slowly to prevent the component from hitting any other part.

Do not work with any part still raised by the hoist or crane.

6. When removing covers which are under internal pressure or under pressure from a spring, always leave two bolts in position on opposite sides. Slowly release the pressure, then slowly loosen the bolts to remove.
7. When removing components, be careful not to break or damage the wiring. Damaged wiring may cause electrical fires.
8. When removing piping, stop the fuel or oil from spilling out. If any fuel or oil drips onto the floor, wipe it up immediately. Fuel or oil on the floor can cause you to slip, or can even start fires.
9. As a general rule, do not use gasoline to wash parts. In particular, use only the minimum of gasoline when washing electrical parts. Do not smoke!
10. Be sure to assemble all parts again in their original places.

Replace any damaged parts with new parts.

When installing hoses and wires, be sure that they will not be damaged by contact with other parts when the machine is being operated.

11. When installing high pressure hoses, make sure that they are not twisted.

Damaged tubes are dangerous, so be extremely careful when installing tubes for high pressure circuits. Also, check that connecting parts are correctly installed.

12. When aligning two holes, never insert your fingers or hand. Be careful not to get your fingers caught in a hole.
13. When assembling or installing parts, always use the specified tightening torques. When installing protective parts such as guards, or parts which vibrate violently or rotate at high speed, be particularly careful to check that they are installed correctly.

Hydraulic system

Only qualified personnel with experience in the handling of highly pressurized fluids is allowed to maintain and repair the hydraulic system.



- **Hydraulic oil is hot and under high pressure!**
Danger of injury to unprotected parts of the body! Always wear special safety equipment, especially safety goggles and gloves.
- **Hydraulic oil is a hazardous substance!**
Danger of injury. Seek medical help immediately if you are exposed to hydraulic oil.

Foreword

General

This shop manual has been prepared as an aid to improve the quality of repairs by giving the service personnel an accurate understanding of the product and by showing them the correct way to perform repairs and make judgements. Make sure you understand the contents of this manual and use it to full effect at every opportunity.

This shop manual mainly contains the necessary technical information for operations performed in a service workshop. For ease of understanding, the manual is divided into the following chapters; these chapters are further divided into the each main group of components:

Structure and function

This section explains the structure and function of each component. It serves not only to give an understanding of the structure, but also serves as reference material for troubleshooting.

Testing and adjusting

This section explains checks to be made before and after performing repairs, as well as adjustments to be made at completion of the checks and repairs. Troubleshooting charts correlating "Problems" to "Causes" are also included in this section.

Disassembly and assembly

This section explains the order to be followed when removing, installing, disassembling or assembling each component, as well as precautions to be taken for these operations.

Maintenance standard

This section gives the judgement standards when inspecting disassembled parts.

NOTE

The specifications contained in this shop manual are subject to change at any time and without any advance notice. Use the specifications given in the book with the latest date.

How to read the shop manual

Volumes

Shop manuals are issued as a guide to carrying out repairs.

Distribution and updating

Any additions, amendments or other changes will be sent to Komatsu distributors.

Get the most up-to-date information before you start any work.

Filing method

1. See the page number on the bottom of the page. File the pages in correct order.
2. Following examples show how to read the page number.

Example 1 (Chassis volume):

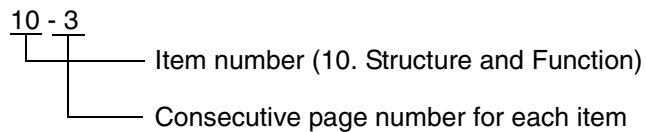

3. Additional pages: Additional pages are indicated by a point (.) and number after the page number. File as in the example.

Example:

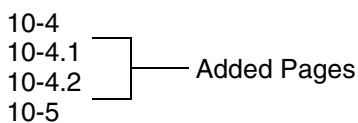



Download the full PDF manual instantly.

Our customer service e-mail:

aservicemanualpdf@yahoo.com