

SHOP MANUAL

KOMATSU

WA40-1

MACHINE MODEL SERIAL No.

WA40-1

1001 and up



CONTENTS

	No. of page
01 GENERAL	01-1
10 ENGINE	
11 STRUCTURE AND FUNCTION	11-1
13 DISASSEMBLY AND ASSEMBLY	13-1
20 POWER TRAIN	
21 STRUCTURE AND FUNCTION	21-1
23 DISASSEMBLY AND ASSEMBLY	23-1
24 MAINTENANCE STANDARD	24-1
40 STEERING SYSTEM	
41 STRUCTURE AND FUNCTION	41-1
43 DISASSEMBLY AND ASSEMBLY	43-1
44 MAINTENANCE STANDARD	44-1
50 BRAKE SYSTEM	
51 STRUCTURE AND FUNCTION	51-1
53 DISASSEMBLY AND ASSEMBLY	53-1
54 MAINTENANCE STANDARD	54-1
60 WORK EQUIPMENT	
61 STRUCTURE AND FUNCTION	61-1
63 DISASSEMBLY AND ASSEMBLY	63-1
64 MAINTENANCE STANDARD	64-1
80 ELECTRIC AND ELECTRONIC SYSTEM	
81 STRUCTURE AND FUNCTION	81-1
90 OTHERS	
91 STRUCTURE AND FUNCTION	91-1
93 DISASSEMBLY AND ASSEMBLY	93-1



IMPORTANT SAFETY NOTICE

Proper service and repair is extremely important for the safe operation of your machine. The service and repair techniques recommended by Komatsu and described in this manual are both effective and safe methods of operation. Some of these operations require the use of tools specially designed by Komatsu for the purpose.

To prevent injury to workers, the symbols  and  are used to mark safety precautions in this manual. The cautions accompanying these symbols should always be followed carefully. If any dangerous situation arises or may possibly arise, first consider safety, and take the necessary actions to deal with the situation.



SAFETY

GENERAL PRECAUTIONS

Mistakes in operation are extremely dangerous. Read the Operation and Maintenance Manual carefully BEFORE operating the machine.

1. Before carrying out any greasing or repairs, read all the precautions given on the decals which are fixed to the machine.
2. When carrying out any operation, always wear safety shoes and helmet. Do not wear loose work clothes, or clothes with buttons missing.
 - Always wear safety glasses when hitting parts with a hammer.
 - Always wear safety glasses when grinding parts with a grinder, etc.
3. If welding repairs are needed, always have a trained, experienced welder carry out the work. When carrying out welding work, always wear welding gloves, apron, glasses, cap and other clothes suited for welding work.
4. When carrying out any operation with two or more workers, always agree on the operating procedure before starting. Always inform your fellow workers before starting any step of the operation. Before starting work, hang UNDER REPAIR signs on the controls in the operator's compartment.
5. Keep all tools in good condition and learn the correct way to use them.

6. Decide a place in the repair workshop to keep tools and removed parts. Always keep the tools and parts in their correct places. Always keep the work area clean and make sure that there is no dirt or oil on the floor. Smoke only in the areas provided for smoking. Never smoke while working.

PREPARATIONS FOR WORK

7. Before adding oil or making any repairs, park the machine on hard, level ground, and block the wheels or tracks to prevent the machine from moving.
8. Before starting work, lower blade, ripper, bucket or any other work equipment to the ground. If this is not possible, insert the safety pin or use blocks to prevent the work equipment from falling. In addition, be sure to lock all the control levers and hang warning signs on them.
9. When disassembling or assembling, support the machine with blocks, jacks or stands before starting work.
10. Remove all mud and oil from the steps or other places used to get on and off the machine. Always use the handrails, ladders or steps when getting on or off the machine. Never jump on or off the machine. If it is impossible to use the handrails, ladders or steps, use a stand to provide safe footing.

PRECAUTIONS DURING WORK

11. When removing the oil filler cap, drain plug or hydraulic pressure measuring plugs, loosen them slowly to prevent the oil from spurting out.
Before disconnecting or removing components of the oil, water or air circuits, first remove the pressure completely from the circuit.
12. The water and oil in the circuits are hot when the engine is stopped, so be careful not to get burned.
Wait for the oil and water to cool before carrying out any work on the oil or water circuits.
13. Before starting work, remove the leads from the battery. Always remove the lead from the negative (–) terminal first.
14. When raising heavy components, use a hoist or crane.
Check that the wire rope, chains and hooks are free from damage.
Always use lifting equipment which has ample capacity.
Install the lifting equipment at the correct places. Use a hoist or crane and operate slowly to prevent the component from hitting any other part. Do not work with any part still raised by the hoist or crane.
15. When removing covers which are under internal pressure or under pressure from a spring, always leave two bolts in position on opposite sides. Slowly release the pressure, then slowly loosen the bolts to remove.
16. When removing components, be careful not to break or damage the wiring. Damaged wiring may cause electrical fires.
17. When removing piping, stop the fuel or oil from spilling out. If any fuel or oil drips on to the floor, wipe it up immediately. Fuel or oil on the floor can cause you to slip, or can even start fires.
18. As a general rule, do not use gasoline to wash parts. In particular, use only the minimum of gasoline when washing electrical parts.
19. Be sure to assemble all parts again in their original places.
Replace any damaged parts with new parts.
 - When installing hoses and wires, be sure that they will not be damaged by contact with other parts when the machine is being operated.
20. When installing high pressure hoses, make sure that they are not twisted. Damaged tubes are dangerous, so be extremely careful when installing tubes for high pressure circuits. Also, check that connecting parts are correctly installed.
21. When assembling or installing parts, always use the specified tightening torques. When installing protective parts such as guards, or parts which vibrate violently or rotate at high speed, be particularly careful to check that they are installed correctly.
22. When aligning two holes, never insert your fingers or hand. Be careful not to get your fingers caught in a hole.
23. When measuring hydraulic pressure, check that the measuring tool is correctly assembled before taking any measurements.
24. Take care when removing or installing the tracks of track-type machines.
When removing the track, the track separates suddenly, so never let anyone stand at either end of the track.

FOREWORD

This shop manual has been prepared as an aid to improve the quality of repairs by giving the serviceman an accurate understanding of the product and by showing him the correct way to perform repairs and make judgements. Make sure you understand the contents of this manual and use it to full effect at every opportunity.

This shop manual mainly contains the necessary technical information for operations performed in a service workshop.

For ease of understanding, the manual is divided into chapters for each main group of components; these chapters are further divided into the following sections.

STRUCTURE AND FUNCTION

This section explains the structure and function of each component. It serves not only to give an understanding of the structure, but also serves as reference material for troubleshooting.

TESTING AND ADJUSTING

This section explains checks to be made before and after performing repairs, as well as adjustments to be made at completion of the checks and repairs.

Troubleshooting charts correlating "Problems" to "Causes" are also included in this section.

DISASSEMBLY AND ASSEMBLY

This section explains the order to be followed when removing, installing, disassembling or assembling each component, as well as precautions to be taken for these operations.

MAINTENANCE STANDARD

This section gives the judgement standards when inspecting disassembled parts.

NOTICE

The specifications contained in this shop manual are subject to change at any time and without any advance notice. Contact your KOMATSU distributor for the latest information.

HOISTING INSTRUCTIONS

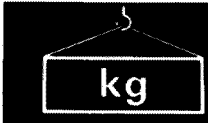

⚠ Heavy parts (25 kg or more) must be lifted with a hoist etc. In the **Disassembly and Assembly** section, every part weighing 25 kg or more is indicated clearly with the symbol 

- If a part cannot be smoothly removed from the machine by hoisting, the following checks should be made:
 - Check for removal of all bolts fastening the part to the relative parts.
 - Check for existence of another part causing interference with the part to be removed.

2. Wire ropes

- Use adequate ropes depending on the weight of parts to be hoisted, referring to the table below:

Wire ropes (Standard "Z" or "S" twist ropes without galvanizing)	
Rope diameter (mm)	Allowable load (tons)
10	1.0
11.2	1.4
12.5	1.6
14	2.2
16	2.8
18	3.6
20	4.4
22.4	5.6
30	10.0
40	18.0
50	28.0
60	40.0

The allowable load value is estimated to be one-sixth or one-seventh of the breaking strength of the rope used.

- Sling wire ropes from the middle portion of the hook.

Slinging near the edge of the hook may cause the rope to slip off the hook during hoisting, and a serious accident can result. Hooks have maximum strength at the middle portion.

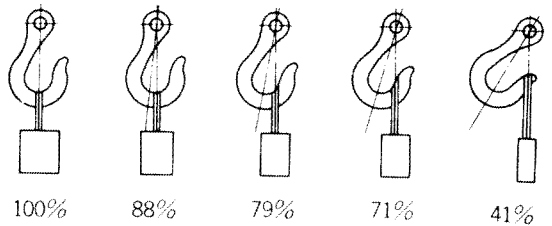

FS0064

- Do not sling a heavy load with one rope alone, but sling with two or more ropes symmetrically wound on to the load.

⚠ Slinging with one rope may cause turning of the load during hoisting, untwisting of the rope, or slipping of the rope from its original winding position on the load, which can result in a dangerous accident.

- Do not sling a heavy load with ropes forming a wide hanging angle from the hook.

When hoisting a load with two or more ropes, the force subjected to each rope will increase with the hanging angles. The table below shows the variation of allowable load (kg) when hoisting is made with two ropes, each of which is allowed to sling up to 1000 kg vertically, at various hanging angles.

When two ropes sling a load vertically, up to 2000 kg of total weight can be suspended. This weight becomes 1000 kg when two ropes make a 120° hanging angle. On the other hand, two ropes are subjected to an excessive force as large as 4000 kg if they sling a 2000 kg load at a lifting angle of 150°.

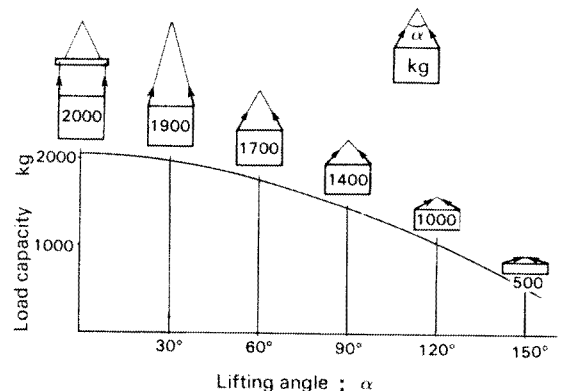



FS0065



STANDARD TIGHTENING TORQUE

1. STANDARD TIGHTENING TORQUE OF BOLTS AND NUTS

The following charts give the standard tightening torques of bolts and nuts. Exceptions are given in sections of "Disassembly and Assembly".

Thread diameter of bolt (mm)	Width across flat (mm)		
		kgm	Nm
6	10	1.35±0.15	13.2±1.4
8	13	3.2±0.3	31.4±2.9
10	17	6.7±0.7	65.7±6.8
12	19	11.5±1.0	112±9.8
14	22	18.0±2.0	177±19
16	24	28.5±3	279±29
18	27	39±4	383±39
20	30	56±6	549±58
22	32	76±8	745±78
24	36	94.5±10	927±98
27	41	135±15	1320±140
30	46	175±20	1720±190
33	50	225±25	2210±240
36	55	280±30	2750±290
39	60	335±35	3280±340

This torque table does not apply to the bolts with which nylon packings or other non-ferrous metal washers are to be used, or which require tightening to otherwise specified torque.

★ Nm (newton meter): 1Nm ≅ 0.1 kgm

2. TIGHTENING TORQUE OF SPLIT FLANGE BOLTS

Use these torques for split flange bolts.

Thread diameter of bolt (mm)	Width across flats (mm)	Tightening torque	
		kgm	Nm
10	14	6.7±0.7	65.7±6.8
12	17	11.5±1	112±9.8
16	22	28.5±3	279±29

STANDARD TIGHTENING TORQUE



3. TIGHTENING TORQUE FOR NUTS OF FLARED

Use these torques for nut part of flared.

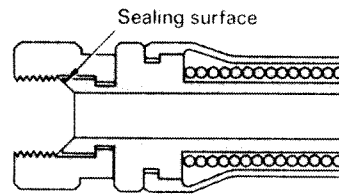

FS0068

Thread diameter of nut part (mm)	Width across flats of nut part (mm)	Tightening torque	
		kgm	Nm
14	19	2.5 ± 0.5	24.5 ± 4.9
18	24	5 ± 2	49 ± 19.6
22	27	8 ± 2	78.5 ± 19.6
24	32	14 ± 3	137.3 ± 29.4
30	36	18 ± 3	176.5 ± 29.4
33	41	20 ± 5	196.1 ± 49
36	46	25 ± 5	245.2 ± 49
42	55	30 ± 5	294.2 ± 49

COATING MATERIALS

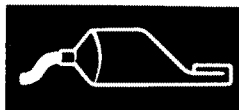

The recommended coating materials prescribed in Komatsu Shop Manuals are listed below.

Nomenclature	Komatsu code	Applications
Adhesives	LT-1A	Used to apply rubber pads, rubber gaskets, and cork plugs.
	LT-1B	Used to apply resin, rubber, metallic and non-metallic parts when a fast, strong seal is needed.
	LT-2*	Preventing bolts, nuts and plugs from loosening and leaking oil.
	LT-3	Provides an airtight, electrically insulating seal. Used for aluminum surfaces.
Liquid gasket	LG-1	Used with gaskets and packings to increase sealing effect.
	LG-3	Heat-resistant gasket for precombustion chambers and exhaust piping.
	LG-4	Used by itself on mounting surfaces on the final drive and transmission cases. (Thickness after tightening: 0.07 – 0.08 mm)
	LG-5	Used by itself to seal grease fittings, tapered screw fittings and tapered screw fittings in hydraulic circuits of less than 50 mm in diameter.
Antifriction compound (Lubricant including molybdenum disulfide)	LM-P	Applied to bearings and taper shafts to facilitate press-fitting and to prevent sticking, burning or rusting.
Grease (Lithium grease)	G2-LI	Applied to bearings, sliding parts and oil seals for lubrication, rust prevention and facilitation of assembling work.
Vaseline	—	Used for protecting battery electrode terminals from corrosion.

*LT-2 is also called LOCTITE in the shop manuals.

ELECTRIC WIRE CODE

In the wiring diagrams, various colors and symbols are employed to indicate the thickness of wires.

This wire code table will help you understand WIRING DIAGRAMS.

Example: 05WB indicates a cable having a nominal number 05 and white coating with black stripe.

CLASSIFICATION BY THICKNESS

Nominal number	Copper wire			Cable O.D. (mm)	Current rating (A)	Applicable circuit
	Number strands	Dia. of strands (mm)	Cross section (mm ²)			
01	11	0.32	0.88	2.4	12	Starting, lighting, signal etc.
02	26	0.32	2.09	3.1	20	Lighting, signal etc.
05	65	0.32	5.23	4.6	37	Charging and signal
15	84	0.45	13.36	7.0	59	Starting (Glow plug)
40	85	0.80	42.73	11.4	135	Starting
60	127	0.80	63.84	13.6	178	Starting
100	217	0.80	109.1	17.6	230	Starting

CLASSIFICATION BY COLOR AND CODE

Priority	Circuits		Starting	Charging	Lighting	Signal	Instrument	Other
	Classification							
1	Primary	Code	B	W	R	G	Y	L
		Color	Black	White	Red	Green	Yellow	Blue
2	Auxiliary	Code	BW	WR	RW	GW	YR	LW
		Color	Black & White	White & Red	Red & White	Green & White	Yellow & Red	Blue & White
3		Code	BY	WB	RB	GR	YB	LR
		Color	Black & Yellow	White & Black	Red & Black	Green & Red	Yellow & Black	Blue & Red
4		Code	BR	WL	RY	GY	YG	LY
		Color	Black & Red	White & Blue	Red & Yellow	Green & Yellow	Yellow & Green	Blue & Yellow
5		Code	—	WY	RG	GB	YL	LB
		Color	—	White & Yellow	Red & Green	Green & Black	Yellow & Blue	Blue & Black
6		Code	—	WG	RL	GL	YW	
		Color	—	White & Green	Red & Blue	Green & Blue	Yellow & White	

01 GENERAL

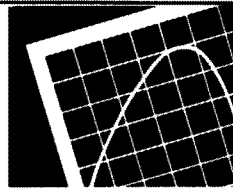

General view	01-2
General assembly drawing	01-3
Specifications	01-4
Engine assembly drawing	01-6
Engine specifications	01-7
Weight of component parts	01-8
Table of oil and coolant capacities	01-9

GENERAL VIEW

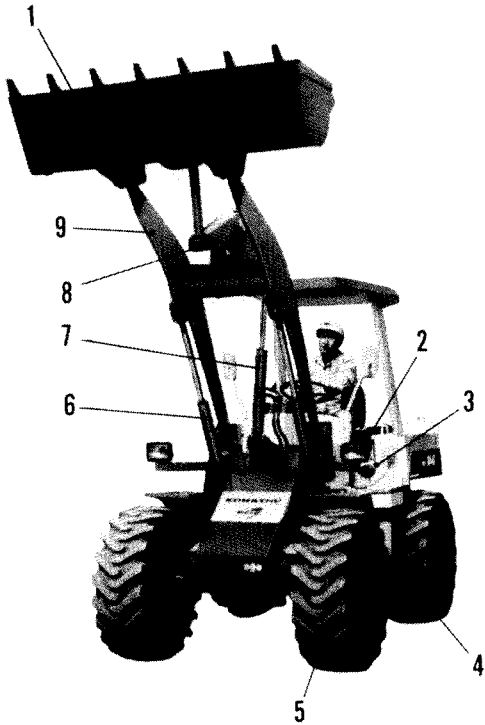

- 1. Bucket
- 2. Head lamp
- 3. Turn signal lamp
- 4. Rear wheel
- 5. Front wheel
- 6. Lift cylinder
- 7. Dump cylinder
- 8. Tilt lever
- 9. Lift arm

P363001

OPTION

This machine has various optional specifications including the ROPS cabin and the rear wheel brake.

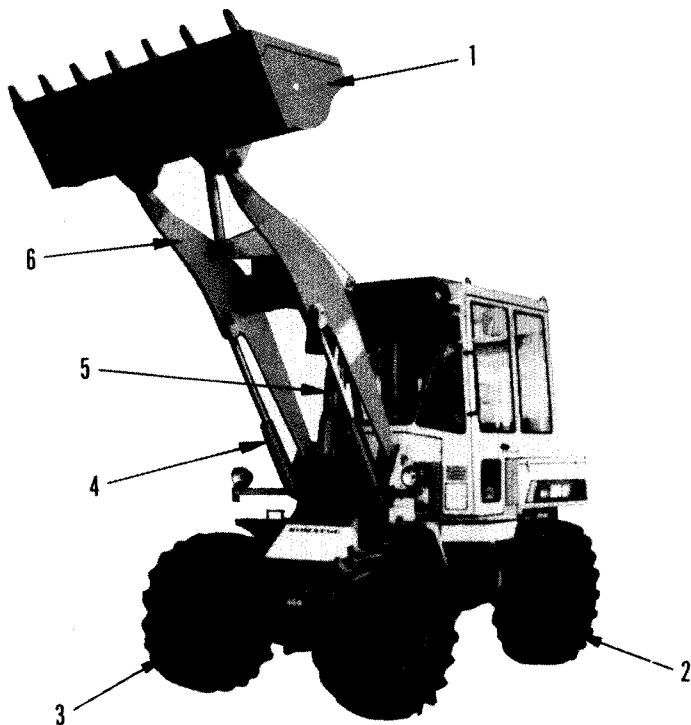

- 1. Bucket
- 2. Rear wheel
- 3. Front wheel
- 4. Lift cylinder
- 5. Dump cylinder
- 6. Lift arm

P363002

GENERAL ASSEMBLY DRAWING

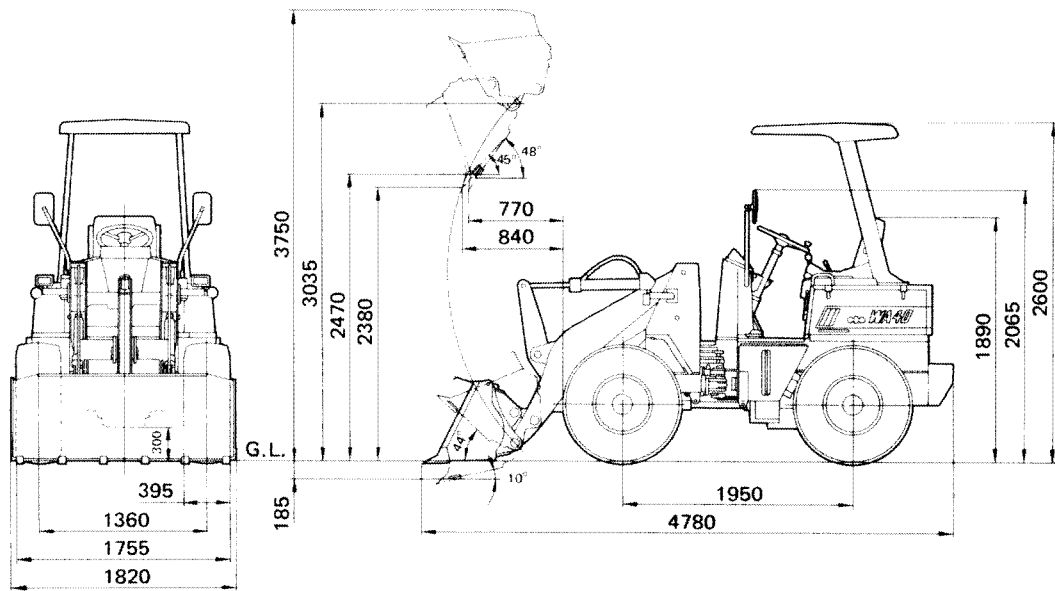

363F001

OPTION

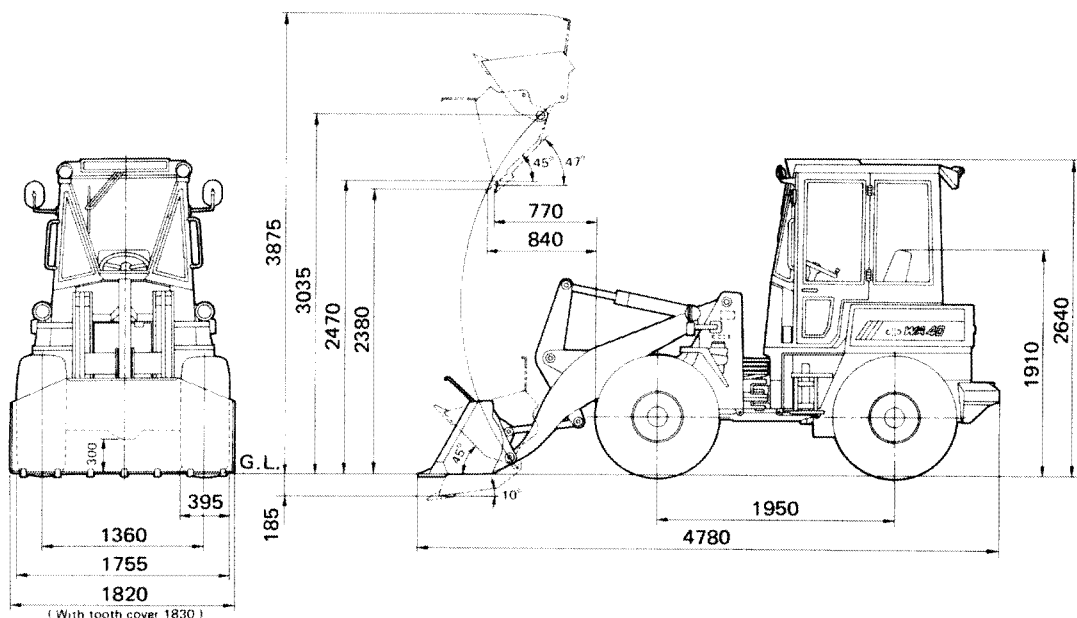

F0363001

Unit: mm

SPECIFICATIONS

Machine Model		WA40-1		
Serial Number		1001 and up		
		STANDARD	OPTION (incl. ABE spec.)	
Weight	Operating weight (kg)	3,400	3,800	
	Load on front axle (kg)	1,510 (44%)	1,640 (43%)	
	Load on rear axle (kg)	1,890 (56%)	2,160 (57%)	
Dimensions	Overall length (mm)	4,780		
	Overall width	Overall width of machine (mm)	1,755	
		Overall width of bucket (mm)	1,820	1,830
	Overall height	Bucket lowered (top of canopy) (mm)	2,600	—
		Bucket lowered (top of ROPS cabin) (mm)	—	2,640
		Bucket lowered (top of operator's seat) (mm)	1,890	1,910
		Bucket raised (mm)	3,750	3,875
	Height of bucket hinge pin (mm)	3,035		
	Dumping clearance (at 45° discharge angle) (mm)	2,470		
	Dumping reach (at 45° discharge angle) (mm)	770		
	Bucket tilt-back angle (deg.)	45		
	Bucket dumping angle (deg.)	47		
	Digging depth (10° forward tilt) (mm)	185		
	Wheelbase (mm)	1,950		
	Tread (front and rear) (mm)	1,360		
Performance	Bucket capacity (heaped) (m ³)	0.5	0.6	
	Max. payload (kg)	900	1,080	
	Max. drawbar pull (kg)	4,400		
	Gradeability (deg.)	30		
	Min. turning radius	Center of outside tire (mm)	3,390	
		Outside of machine (mm)	4,050	
	Travel speed	Forward	1st (km/h)	3.4
			2nd (km/h)	7.5
			3rd (km/h)	20.0
		Reverse	1st (km/h)	3.4
2nd (km/h)			7.5	
3rd (km/h)			20.0	

Note: Specifications are subject to change without notice.

Machine Model			WA40-1
Serial Number			1001 and up
Power train	Drive type		Front and rear wheel drive
	Transmission		Planetary gear, hydraulically actuated, forced lubrication, F3, R3
	Axle	Front axle	Fixed frame, semi-floating
		Rear axle	Fixed frame, semi-floating
	Differential		Straight bevel gear
	Final drive		1-stage spiral bevel gear
	Wheel	Tire	
Air pressure		STANDARD	1.8 kg/cm ²
		OPTION	2.0 kg/cm ²
Steering system	Steering type		Articulated steering
	Actuation system		Fully hydraulic power steering (ORBITROL type)
	Suspension	Type	Fixed axle, chassis suspension
		Front axle	Fixed frame
		Rear axle	Fixed frame
Brake system	Service brake	STANDARD	Sealed, wet, multiple disc type (hydraulic) actuated on transmission brake shaft
		OPTION	STANDARD spec. and non-sealed, dry, disc type (hydraulic), actuated on 2-wheel
	Parking brake		Sealed, wet, multiple disc type (mechanical), actuated on transmission brake shaft
Hydraulic system	Work equipment pump		Gear type (SAL025)
	Work equipment pump setting pressure	STANDARD	190 kg/cm ²
		OPTION	175 kg/cm ²
	Steering pump		Gear type (LAR012)
	Steering pump setting pressure		155 kg/cm ²
	No. of cylinders-bore x stroke (No. – mm x mm)	Lift cylinder	2 – 70 x 525
Dump cylinder		1 – 70 x 440	
Steering cylinder		1 – 70 x 210	

ENGINE ASSEMBLY DRAWING

L.H. side view

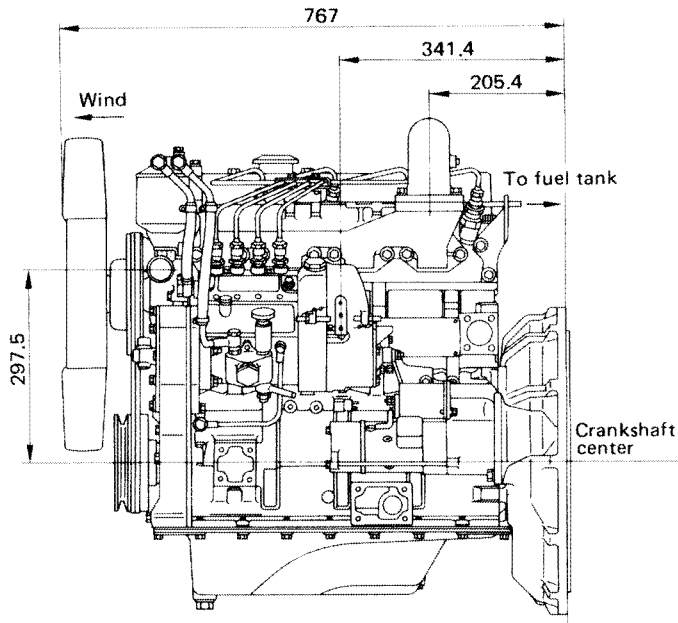

Rear view

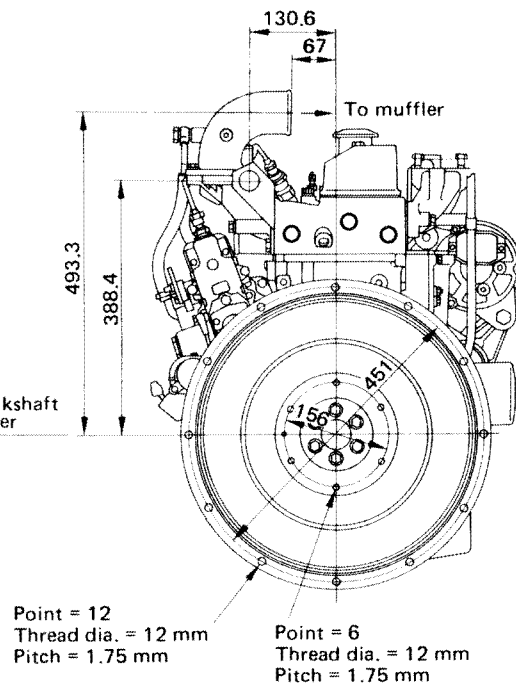

R.H. side view

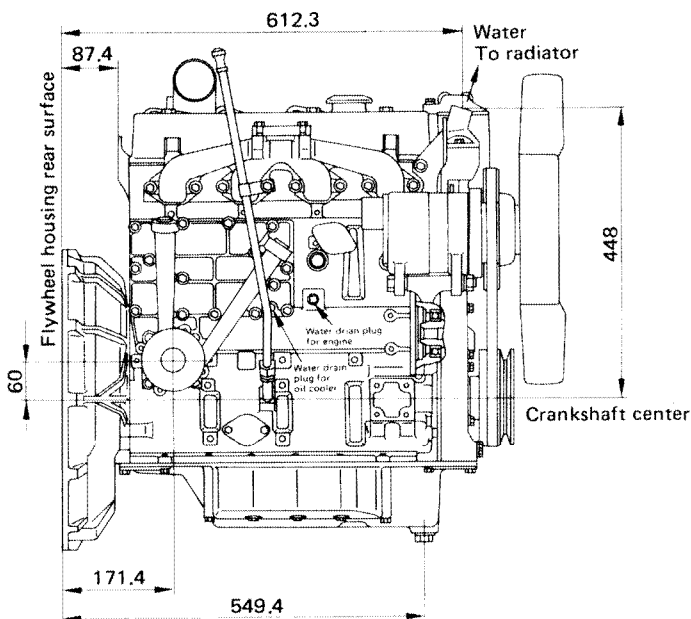

Front view

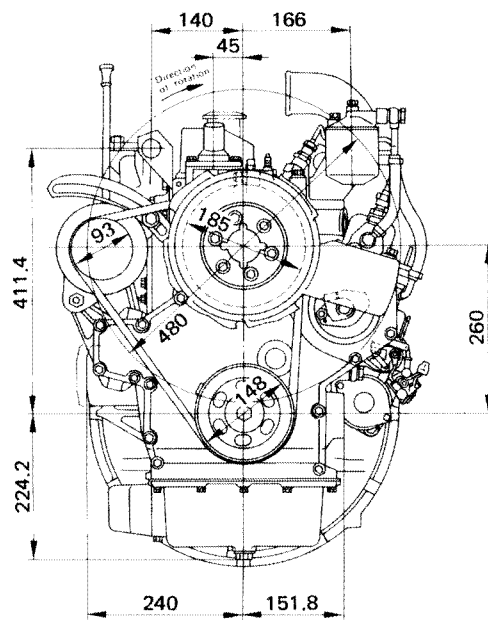

363F002

Unit: mm



Download the full PDF manual instantly.

Our customer service e-mail:

aservicemanualpdf@yahoo.com