

Shop Manual

WHEEL LOADER

WA380-7

SERIAL NUMBERS 10001 and up

KOMATSU

SHOP MANUAL

WHEEL LOADER

WA380-7

Model **Serial Number**

WA380-7 10001 and up

00 Index and foreword

Index

00 Index and foreword	00-1
Index	00-2
Foreword, safety and general information	00-17
Important safety notice	00-17
How to read the shop manual	00-24
Explanation of terms for maintenance standard	00-26
Handling of fuel system devices	00-28
Handling of intake system parts	00-29
Handling of hydraulic equipment	00-30
Method of disconnecting and connecting push-pull type coupler	00-32
Handling of electrical equipment	00-35
How to read electric wire code	00-43
Precautions when performing operation	00-46
Standard tightening torque table	00-49
List of abbreviation	00-53
Conversion table	00-57
01 Specification	01-1
Table of contents	01-2
Specifications	01-3
Specification drawing	01-3
Specification	01-5
Weight table	01-11
Table of fuel, coolant and lubricants	01-13
10 Structure and function	10-1
Table of contents	10-2
Engine and cooling system	10-4
Engine related parts	10-4
KVTG	10-6
EGR system piping drawing	10-12
EGR system circuit diagram	10-14
EGR valve	10-16
EGR cooler	10-18
KCCV layout drawing	10-19
KCCV ventilator	10-21
KDPF	10-23
Cooling system	10-29
Cooling fan pump	10-32
Cooling fan motor	10-41
Power train	10-49
Power train system	10-49
Drive shaft	10-52
Power train piping drawing	10-53
Transmission control	10-54
Torque converter	10-56
Transmission	10-61
Transmission control valve	10-79
Forward and reverse clutch ECMV and gear speed clutch ECMV	10-82
Lockup clutch ECMV	10-89
Main relief and torque converter relief valve	10-92
Axle	10-94
Differential	10-96
Limited slip differential	10-100
Final drive	10-104
Steering system	10-106
Layout of steering devices	10-106
Steering column	10-107
Steering pump	10-108

Steering valve	10-120
Orbit-roll valve	10-134
Stop valve	10-140
Emergency steering motor	10-141
Emergency steering pump	10-142
Brake system	10-143
Layout of brake parts	10-143
Charge valve	10-145
Brake valve	10-151
Accumulator (for brake)	10-155
Brake	10-156
Parking brake control	10-159
Parking brake	10-160
Parking brake solenoid valve	10-161
Parking brake emergency release valve	10-164
Undercarriage and frame	10-165
Axle mount and center hinge pin	10-165
Tire	10-166
Hydraulic system	10-168
Hydraulic component layout	10-168
Work equipment control	10-170
Hydraulic tank	10-171
Double type gear pump	10-173
Work equipment pump	10-174
Control valve	10-186
CLSS	10-196
Hydraulic circuit diagram and name of valves	10-199
Accumulator charge valve	10-214
Stabilizer valve	10-218
Work equipment lock solenoid valve	10-223
Accumulator (for PPC circuit)	10-224
Accumulator (for E.C.S.S.)	10-225
Work equipment	10-226
Work equipment linkage	10-226
Bucket	10-227
Bucket positioner and boom positioner	10-228
Cab and its attachments	10-229
ROPS cab	10-229
Electrical system	10-230
Engine control system	10-230
Preheating system	10-232
Engine power mode selector circuit	10-234
Engine output limit function	10-235
Automatic warm-up function	10-236
Parking brake control system	10-237
System operating lamp function	10-239
Battery disconnect switch function	10-241
Transmission controller system	10-243
Work equipment control system	10-278
Machine monitor system	10-299
Rear view monitor system	10-323
KOMTRAX system	10-326
System component parts	10-329
Sensors	10-354
20 Standard value tables	20-1
Table of contents	20-2
Standard service value table	20-3
Standard value table for engine	20-3
Standard value table for machine	20-5

00 Index and foreword

Index

30 Testing and adjusting	30-1
Table of contents	30-2
General information on testing and adjusting	30-4
Tools for testing and adjusting	30-4
Sketch of tools for testing and adjusting	30-9
Engine and cooling system	30-10
Measuring engine speed	30-10
Measuring boost pressure	30-11
Testing exhaust gas temperature	30-13
Testing exhaust gas color	30-15
Testing and adjusting valve clearance	30-17
Measuring compression pressure	30-19
Testing blowby pressure	30-23
Testing engine oil pressure	30-25
Testing EGR valve and KVGT driving oil pressure	30-26
Testing fuel pressure	30-27
Testing fuel delivery, return and leakage	30-32
Bleeding air from fuel system	30-38
Testing fuel circuit for leakage	30-40
Handling cylinder cutout mode operation	30-41
Handling no injection cranking operation	30-42
Check of KDPF and muffler stack for looseness and damage	30-43
Check of installed condition of cylinder head and manifolds	30-44
Checking engine piping for damage and looseness	30-45
Testing and adjusting air conditioner compressor belt tension	30-46
Replacing alternator belt	30-47
Power train system	30-48
Adjusting transmission output speed sensor	30-48
Adjusting transmission input speed sensor	30-49
Flushing procedure for torque converter and transmission hydraulic circuit	30-50
Retrieval of disabled machine due to transmission valve failure	30-51
Checking oil leakage from axle final drive	30-53
Checking drive shaft for looseness, play, and damage	30-54
Testing and adjusting power train oil pressure	30-55
Steering system	30-70
Checking directional lever	30-70
Testing steering wheel	30-71
Testing work equipment control lever	30-73
Testing and adjusting steering circuit pressure	30-74
Bleeding air from steering cylinder circuit	30-77
Testing and adjusting steering stopper valve	30-78
Brake system	30-79
Testing brake pedal	30-79
Testing and adjusting brake pedal linkage	30-80
Testing braking performance	30-81
Testing and adjusting accumulator charge pressure	30-82
Testing wheel brake oil pressure	30-84
Measuring lowering of wheel brake pressure	30-85
Measuring wear of wheel brake disc	30-88
Bleeding air from wheel brake circuit	30-89
Releasing remaining pressure in brake accumulator circuit	30-90
Testing parking brake performance	30-91
Testing parking brake oil pressure	30-92
Testing wear of parking brake disc	30-94
Method of releasing parking brake manually	30-95
Hydraulic system	30-96
Checking fan speed	30-96
Measuring fan pump circuit oil pressure	30-97
Bleeding air from hydraulic fan circuit	30-98

Testing and adjusting work equipment PPC oil pressure	30-99
Testing and adjusting work equipment oil pressure	30-102
Bleeding air from work equipment circuit	30-106
Releasing remaining pressure from work equipment circuit	30-107
Checking of E.C.S.S. accumulator nitrogen gas pressure and procedure for charging accumulator with nitrogen gas	30-108
Work equipment	30-112
Testing and adjusting bucket position detection lever	30-112
Testing and adjusting boom position detection lever	30-113
Electrical system	30-114
Adjusting replaced, reassembled or added sensor, controller, etc. with machine monitor	30-114
Special functions of machine monitor	30-116
Angle adjustment of rear view camera	30-205
Handling voltage circuit of engine controller	30-206
Handling battery disconnect switch	30-207
Testing diodes	30-208
Pm clinic	30-209
Pm Clinic service	30-209
Check sheet	30-210
40 Troubleshooting	40-1
Table of contents	40-2
General information on troubleshooting	40-11
Instruction on troubleshooting	40-11
Sequence of events in troubleshooting	40-13
Check before troubleshooting	40-15
Classification and procedures for troubleshooting	40-25
Information in troubleshooting table	40-28
Connector list and layout	40-30
Procedure for troubleshooting wiring harness of pressure sensor system for open circuit	40-46
Fuse location table	40-49
Precautions for cleaning and replacing KDPF (KCSF, KDOC)	40-52
Dummy temperature sensor (for KDOC and KDPF temperature sensors)	40-55
Short-circuit connector (for CA1883 and CA3135)	40-56
Failure codes table	40-57
Troubleshooting by failure code (Display of code)	40-71
Failure code [1500L0] Double Engagement of T/M Clutches	40-71
Failure code [15SAL1] Release Trouble of ECMV (Forward)	40-72
Failure code [15SALH] Malfunction of ECMV (Forward)	40-74
Failure code [15SBL1] Release Trouble of ECMV (Reverse)	40-76
Failure code [15SBLH] Malfunction of ECMV (Reverse)	40-78
Failure code [15SEL1] Release Trouble of ECMV (1st)	40-80
Failure code [15SELH] Malfunction of ECMV (1st)	40-82
Failure code [15SFL1] Release Trouble of ECMV (2nd)	40-84
Failure code [15SFLH] Malfunction of ECMV (2nd)	40-86
Failure code [15SGL1] Release Trouble of ECMV (3rd)	40-88
Failure code [15SGLH] Malfunction of ECMV (3rd)	40-90
Failure code [15SHL1] Release Trouble of ECMV (4th)	40-92
Failure code [15SHLH] Malfunction of ECMV (4th)	40-94
Failure code [2F00MA] Failure of Parking Brake Circuit	40-96
Failure code [2G42ZG] Accumulator Oil Pressure Low (Front)	40-99
Failure code [2G43ZG] Accumulator Oil Pressure Low (Rear)	40-101
Failure code [879AKA] A/C Inner Sensor Open Circuit	40-103
Failure code [879AKB] A/C Inner Sensor Short Circuit	40-104
Failure code [879BKA] A/C Outer Sensor Open Circuit	40-105
Failure code [879BKA] A/C Outer Sensor Open Circuit	40-106
Failure code [879BKB] A/C Outer Sensor Short Circuit	40-107
Failure code [879CKA] Ventilating Sensor Open Circuit	40-108

00 Index and foreword

Index

Failure code [879CKB] Ventilating Sensor Short Circuit	40-109
Failure code [879DKZ] Sunlight Sensor Open or Short Circuit	40-110
Failure code [879EMC] Ventilation Damper Abnormality	40-111
Failure code [879FMC] Air Mix Damper Abnormality	40-112
Failure code [989A00] Engine Overrun Prevention Activated	40-113
Failure code [989L00] Engine Controller Lock Caution 1	40-114
Failure code [989M00] Engine Controller Lock Caution 2	40-115
Failure code [989N00] Engine Controller Lock Caution 3	40-116
Failure code [A1U0N3] HC Desorb Request 1	40-117
Failure code [A1U0N4] HC desorb request 2	40-119
Failure code [AA10NX] Air Cleaner Clogging	40-121
Failure code [B@BAZG] Eng Oil Press Low	40-123
Failure code [B@BAZK] Engine Oil Level Low	40-124
Failure code [B@BCNS] Eng Water Overheat 1	40-125
Failure code [B@BCZK] Eng Water Level Low	40-126
Failure code [B@CENS] T/C Oil Temp. Overheat	40-128
Failure code [B@HANS] HYD Oil Temp. Overheat	40-129
Failure code [CA115] Eng Ne and Bkup Speed Sens Error	40-130
Failure code [CA122] Chg Air Press Sensor High Error	40-131
Failure code [CA123] Chg Air Press Sensor Low Error	40-133
Failure code [CA131] Throttle Sensor High Error	40-135
Failure code [CA132] Throttle Sensor Low Error	40-137
Failure code [CA144] Coolant Temp Sens High Error	40-139
Failure code [CA145] Coolant Temp Sens Low Error	40-141
Failure code [CA153] Chg Air Temp Sensor High Error	40-143
Failure code [CA154] Chg Air Temp Sensor Low Error	40-145
Failure code [CA187] Sensor 2 Supply Volt Low Error	40-147
Failure code [CA221] Ambient Press Sens High Error	40-149
Failure code [CA222] Ambient Press Sens Low Error	40-151
Failure code [CA227] Sensor 2 Supply Volt High Error	40-153
Failure code [CA234] Eng Overspeed	40-154
Failure code [CA238] Ne Speed Sensor Supply Volt Error	40-155
Failure code [CA239] Ne Speed Sens Supply Volt High Error	40-156
Failure code [CA271] IMV/PCV1 Short Error	40-157
Failure code [CA272] IMV/PCV1 Open Error	40-159
Failure code [CA295] Ambient Press Sens In Range Error	40-161
Failure code [CA322] Inj #1(L#1) Open/Short Error	40-162
Failure code [CA323] Inj #5(L#5) Open/Short Error	40-164
Failure code [CA324] Inj #3(L#3) Open/Short Error	40-166
Failure code [CA325] Inj #6(L#6) Open/Short Error	40-168
Failure code [CA331] Inj #2(L#2) Open/Short Error	40-170
Failure code [CA332] Inj #4(L#4) Open/Short Error	40-172
Failure code [CA343] EMC Critical Internal Failure	40-174
Failure code [CA351] Injectors Drive Circuit Error	40-175
Failure code [CA352] Sensor 1 Supply Volt Low Error	40-176
Failure code [CA356] Mass Air Flow Sensor High Error	40-178
Failure code [CA357] Mass Air Flow Sensor Low Error	40-180
Failure code [CA386] Sensor 1 Supply Volt High Error	40-182
Failure code [CA428] Water in Fuel Sensor High Error	40-183
Failure code [CA429] Water in Fuel Sensor Low Error	40-185
Failure code [CA431] Idle Validation Sw Error	40-187
Failure code [CA432] Idle Validation Process Error	40-190
Failure code [CA435] Eng Oil Press Sw Error	40-193
Failure code [CA441] Battery Voltage Low Error	40-194
Failure code [CA442] Battery Voltage High Error	40-196
Failure code [CA449] Rail Press Very High Error	40-197
Failure code [CA451] Rail Press Sensor High Error	40-198
Failure code [CA452] Rail Press Sensor Low Error	40-200
Failure code [CA488] Chg Air Temp High Torque Derate	40-201

Failure code [CA515] Rail Press Sens Sup Volt High Error	40-202
Failure code [CA516] Rail Press Sens Sup Volt Low Error	40-204
Failure code [CA553] Rail Press High Error	40-206
Failure code [CA555] Crankcase Press High Error 1	40-207
Failure code [CA556] Crankcase Press High Error 2	40-208
Failure code [CA559] Rail Press Low Error	40-209
Failure code [CA595] Turbo Speed High Error 2	40-211
Failure code [CA687] Turbo Speed Low Error	40-212
Failure code [CA689] Eng Ne Speed Sensor Error	40-214
Failure code [CA691] Intake Air Temp Sens High Error	40-216
Failure code [CA692] Intake Air Temp Sens Low Error	40-218
Failure code [CA697] ECM Int Temp Sensor High Error	40-220
Failure code [CA698] ECM Int Temp Sensor Low Error	40-221
Failure code [CA731] Eng Bkup Speed Sens Phase Error	40-222
Failure code [CA778] Eng Bkup Speed Sensor Error	40-224
Failure code [CA1117] Persistent Data Lost Error	40-228
Failure code [CA1664] KDOC Malfunction	40-229
Failure code [CA1691] Ineffective Regeneration	40-232
Failure code [CA1695] Sensor 5 Supply Volt High Error	40-235
Failure code [CA1696] Sensor 5 Supply Volt Low Error	40-236
Failure code [CA1843] Crankcase Press Sens High Error	40-238
Failure code [CA1844] Crankcase Press Sens Low Error	40-240
Failure code [CA1879] KDPF Delta P Sensor High Error	40-242
Failure code [CA1881] KDPF Delta P Sensor Low Error	40-244
Failure code [CA1883] KDPF Delta P Sens In Range Error	40-246
Failure code [CA1921] KDPF Soot Load High Error 1	40-251
Failure code [CA1922] KDPF Soot Load High Error 2	40-253
Failure code [CA1942] Crankcase Press Sens In Range Error	40-257
Failure code [CA1993] KDPF Delta Pressure Low Error	40-258
Failure code [CA2185] Throt Sensor Sup Volt High Error	40-261
Failure code [CA2186] Throt Sensor Sup Volt Low Error	40-263
Failure code [CA2249] Rail Press Very Low Error	40-265
Failure code [CA2271] EGR Valve Pos Sens High Error	40-266
Failure code [CA2272] EGR Valve Pos Sens Low Error	40-268
Failure code [CA2288] Turbo Speed High Error 1	40-271
Failure code [CA2311] IMV Solenoid Error	40-272
Failure code [CA2349] EGR Valve Solenoid Open Error	40-273
Failure code [CA2353] EGR Valve Solenoid Short Error	40-275
Failure code [CA2357] EGR Valve Servo Error	40-277
Failure code [CA2373] Exhaust Manifold Press Sens High error	40-278
Failure code [CA2374] Exhaust Manifold Press Sens Low error	40-280
Failure code [CA2375] EGR Orifice Temp Sens High Error	40-282
Failure code [CA2376] EGR Orifice Temp Sens Low Error	40-284
Failure code [CA2381] KVGT Pos Sens High Error	40-286
Failure code [CA2382] KVGT Pos Sens Low Error	40-288
Failure code [CA2383] KVGT Solenoid Open Error	40-291
Failure code [CA2386] KVGT Solenoid Short Error	40-293
Failure code [CA2387] KVGT Servo Error	40-295
Failure code [CA2554] Exh Manifold Press Sens In Range Error	40-296
Failure code [CA2555] Grid Htr Relay Volt Low Error	40-297
Failure code [CA2556] Grid Htr Relay Volt High Error	40-299
Failure code [CA2637] KDOC Face Plugging	40-301
Failure code [CA2639] Manual Stationary Regeneration Request	40-303
Failure code [CA2961] EGR Orifice Temp High Error 1	40-306
Failure code [CA2973] Chg Air Press Sensor In Range Error	40-307
Failure code [CA3133] KDPF Outlet Press Sens High Error	40-308
Failure code [CA3134] KDPF Outlet Press Sens Low Error	40-310
Failure code [CA3135] KDPF Outlet Press Sens In Range Error	40-312
Failure code [CA3251] KDOC Inlet Temp High Error	40-316

Failure code [CA3253] KDOC Temp Error - Non Regeneration	40-319
Failure code [CA3254] KDOC Outlet Temp High Error 1	40-322
Failure code [CA3255] KDPF Temp Error - Non Regeneration.....	40-325
Failure code [CA3256] KDPF Outlet Temp High Error 1	40-328
Failure code [CA3311] KDOC Outlet Temp High Error 2.....	40-331
Failure code [CA3312] KDPF Outlet Temp High Error 2	40-334
Failure code [CA3313] KDOC Inlet Temp Sensor Low Error	40-337
Failure code [CA3314] KDOC Inlet Temp Sens High Error	40-340
Failure code [CA3315] KDOC Inlet Temp Sens In Range Error.....	40-344
Failure code [CA3316] KDOC Outlet Temp Sens Low Error	40-349
Failure code [CA3317] KDOC Outlet Temp Sens High Error.....	40-352
Failure code [CA3318] KDOC Outlet Temp Sens In Range Error	40-356
Failure code [CA3319] KDPF Outlet Temp Sens High Error	40-361
Failure code [CA3321] KDPF Outlet Temp Sens Low Error	40-365
Failure code [CA3322] KDPF Outlet Temp Sens In Range Error.....	40-368
Failure code [CA3419] Mass Air Flow Sensor Sup Volt High Error	40-372
Failure code [CA3421] Mass Air Flow Sensor Sup Volt Low Error.....	40-374
Failure code [D150KA] Disconnection of Emerg. Steering Relay	40-376
Failure code [D150KB] Ground Fault of Emerg. Steering Relay	40-378
Failure code [D150KY] Hot Short of Emergency Steering Relay	40-380
Failure code [D160KA] Disconnection of Backup Lamp Relay Output	40-382
Failure code [D160KB] Ground Fault of Backup Lamp Relay Output.....	40-384
Failure code [D160KY] Hot Short of Backup Lamp Relay Output	40-386
Failure code [D191KA] Disconnection of Neutral Output Relay.....	40-388
Failure code [D191KB] Ground Fault of Neutral Output Relay	40-391
Failure code [D191KY] Hot Short of Neutral Output Relay.....	40-394
Failure code [D192KA] Disconnection of ECSS Solenoid.....	40-396
Failure code [D192KB] Ground Fault of ECSS Solenoid	40-398
Failure code [D192KY] Hot Short of ECSS Solenoid	40-399
Failure code [D19JKZ] Personal Code Relay Abnormality.....	40-400
Failure code [D1E6KA] Disconnection of Parking Brake Relay	40-402
Failure code [D1E6KB] Ground Fault of Parking Brake Relay.....	40-404
Failure code [D1E6KY] Hot Short of Parking Brake Relay	40-406
Failure code [D5ZHKA] Failure of Key SW C Signal	40-408
Failure code [D5ZHKB] Key SW C Signal Short Circuit.....	40-410
Failure code [D5ZHKZ] Failure of Key SW C Signal	40-412
Failure code [D5ZHL6] Disconnection of Key SW C	40-414
Failure code [D811MC] KOMTRAX Error.....	40-416
Failure code [D862KA] GPS Antenna Open Circuit	40-417
Failure code [D8ALKA] Operating Lamp Open Circuit (KOMTRAX)	40-418
Failure code [D8ALKB] Operating Lamp Short Circuit (KOMTRAX)	40-420
Failure code [D8AQK4] CAN2 Discon (KOMTRAX) 2	40-422
Failure code [D8AQKR] CAN2 Discon (KOMTRAX)	40-423
Failure code [DAF0KT] Abnormality of Non-volatile Memory (MON)	40-424
Failure code [DAF0MB] Monitor ROM Abnormality.....	40-425
Failure code [DAF0MC] Monitor Error	40-426
Failure code [DAF3KK] Controller Power Source Low (MON).....	40-427
Failure code [DAF8KB] Camera Power Supply Short Circuit	40-429
Failure code [DAFDKB] Monitor 12V Power Output Short Circuit.....	40-430
Failure code [DAFGMC] GPS Module Error.....	40-432
Failure code [DAFLKA] Operating Lamp Open Circuit (MON).....	40-433
Failure code [DAFLKB] Operating Lamp Short Circuit (MON).....	40-435
Failure code [DAFQKR] CAN2 Discon (Monitor)	40-437
Failure code [DAQ0KK] Controller Power Source Low (T/M).....	40-438
Failure code [DAQ0KT] Abnormality of Non-volatile Memory (T/M).....	40-441
Failure code [DAQ0MC] T/M Con Error	40-442
Failure code [DAQ2KK] Solenoid Power Source Low (T/M)	40-443
Failure code [DAQ4KB] Ground Fault of Sol. Self-Holding Relay (TM)	40-446
Failure code [DAQ9KQ] Inconsistency of Model Selection (T/M)	40-448

Failure code [DAQLKA] Operating Lamp Open Circuit (T/M)	40-449
Failure code [DAQLKB] Operating Lamp Short Circuit (T/M)	40-451
Failure code [DAQQKR] CAN2 Discon (Transmission Con)	40-453
Failure code [DAQRKR] CAN1 Discon (Transmission Con)	40-454
Failure code [DAQRMA] Inconsistency of Option Selection (T/M)	40-455
Failure code [DAZ9KQ] A/C Model Selection Abnormality	40-456
Failure code [DAZQKR] CAN2 Discon (Aircon ECU)	40-457
Failure code [DB2QKR] CAN2 Discon (Engine Con)	40-458
Failure code [DB2RKR] CAN1 Discon (Engine Con)	40-463
Failure code [DB90KK] Drop in BBC Controller Main Power Source	40-469
Failure code [DB90KT] Abnormality of Non-volatile Memory (BBC)	40-471
Failure code [DB90MC] BBC Error	40-472
Failure code [DB91KA] Disconnection of Key SW ACC (BBC)	40-473
Failure code [DB92KK] Solenoid Power Source Low (BBC)	40-475
Failure code [DB95KX] Failure of 5 V Power Source 1	40-477
Failure code [DB96KX] Failure of 5 V Power Source 2	40-479
Failure code [DB99KQ] Inconsistency of Model Selection (BBC)	40-481
Failure code [DB9LKA] Operating Lamp Open Circuit (BBC)	40-482
Failure code [DB9LKB] Operating Lamp Short Circuit (BBC)	40-484
Failure code [DB9QKR] CAN2 Discon (Bucket Boom Con)	40-486
Failure code [DB9RKR] CAN1 Discon (Bucket Boom Con)	40-487
Failure code [DB9RMA] Inconsistency of Option Selection (BBC)	40-488
Failure code [DBE5KX] Failure of 5 V Power Source	40-489
Failure code [DBE6KX] Failure of 24 V Power Source	40-491
Failure code [DD1ALD] Ground Fault of Remote Positioner Set SW	40-493
Failure code [DDAAL6] Disconnection of Secondary ENG Stop SW	40-495
Failure code [DDB6L4] Neutral Signal Malfunction	40-497
Failure code [DDD1LD] Failure of Bucket Positioner Set Switch	40-500
Failure code [DDK3KA] FNR SW Input Signal Disconnection	40-502
Failure code [DDK3KB] FNR SW Input Signal Short Circuit	40-504
Failure code [DDK6KA] FNR Lever Input Signal Disconnection	40-506
Failure code [DDK6KB] FNR Lever Input Signal Short Circuit	40-509
Failure code [DDNRKY] Hot Short of Work Equipment Lock SW	40-511
Failure code [DDT0L4] Failure of Shift Mode Select SW	40-513
Failure code [DDT4LD] Ground Fault of T/M Cut Off Set SW Signal	40-515
Failure code [DDT9LD] Ground Fault of T/M Cut Off SW Signal	40-517
Failure code [DDW9LD] Ground Fault of Kickdown Switch	40-519
Failure code [DDWLLD] Ground Fault of T/M Shift Hold SW	40-521
Failure code [DF10KA] Disconnection of Shift Lever Input	40-523
Failure code [DF10KB] Ground Fault of Shift Lever Input	40-525
Failure code [DGF1KA] Disconnection of T/M Oil Temp. Sensor	40-528
Failure code [DGF1KB] Ground Fault of T/M Oil Temp. Sensor	40-530
Failure code [DGH2KX] Out of Range of HYD Oil Temp. Sensor	40-532
Failure code [DGR2KB] Ground Fault of Brake Oil Temp. Sensor	40-534
Failure code [DGR2KZ] Failure of Brake Oil Temp. Sensor	40-535
Failure code [DGT1KA] Disconnection of T/C Oil Temp. Sensor	40-537
Failure code [DGT1KB] Ground Fault of T/C Oil Temp. Sensor	40-539
Failure code [DH21KA] Failure of Loader Pump Press. Sensor	40-541
Failure code [DH21KB] Loader Pump Press. Sensor Short Circuit	40-543
Failure code [DHA4KA] Failure of Air Cleaner Sensor Circuit	40-545
Failure code [DHPCKX] Out of Range of Boom Bottom Press. Sensor	40-547
Failure code [DHPDKX] Out of Range of Boom Head Press. Sensor	40-549
Failure code [DHT1KX] Out of Range of T/M Cut Off Press. Sensor	40-551
Failure code [DHT5KX] Out of Range of T/C Input Pressure Sensor	40-553
Failure code [DHT7KX] Out of Range of T/C Output Pressure Sensor	40-556
Failure code [DHT8KA] Failure of Steering Pump Press. Sensor	40-558
Failure code [DHT8KB] Steering Pump Press. Sensor Short Circuit	40-560
Failure code [DHT8ZG] Steering Oil Pressure Low	40-562
Failure code [DHUDKA] Failure of Emrg. Steering Press. Sensor	40-563

Failure code [DHUDBK] Emrg. Steering Press. S. Short Circuit	40-565
Failure code [DJF1KA] Disconnection of Fuel Level Sensor	40-567
Failure code [DK55KA] Failure of FNR Lever Potentio	40-569
Failure code [DK55KY] Hot Short of FNR Lever Potentio Circuit	40-571
Failure code [DK55L5] Failure of FNR Lever Potentio	40-573
Failure code [DK59KA] Failure of Boom Lever Potentio (Main)	40-574
Failure code [DK59KY] Hot Short of Boom Lever Potentio (Main)	40-577
Failure code [DK59L8] Boom Lever Potentio (Main & Sub) Disagree	40-579
Failure code [DK5AKA] Failure of Boom Lever Potentio (Sub)	40-583
Failure code [DK5AKY] Hot Short of Boom Lever Potentio (Sub)	40-586
Failure code [DK5BKA] Failure of Bucket Lever Potentio (Main)	40-588
Failure code [DK5BKY] Hot Short of Bucket Lever Potentio (Main)	40-590
Failure code [DK5BL8] Bucket Lever Potentio (Main&Sub) Disagree	40-592
Failure code [DK5CKA] Failure of Bucket Lever Potentio (Sub)	40-596
Failure code [DK5CKY] Hot Short of Bucket Lever Potentio (Sub)	40-598
Failure code [DK5DKA] Failure of 3rd Lever Potentio (Main)	40-600
Failure code [DK5DKY] Hot Short of 3rd Lever Potentio (Main)	40-602
Failure code [DK5DL8] 3rd Lever Potentio (Main & Sub) Disagree	40-604
Failure code [DK5EKA] Failure of 3rd Lever Potentio (Sub)	40-607
Failure code [DK5EKY] Hot Short of 3rd Lever Potentio (Sub)	40-609
Failure code [DK5KKA] Failure of 4th Lever Potentio (Main)	40-611
Failure code [DK5KKY] Hot Short of 4th Lever Potentio (Main)	40-613
Failure code [DK5KL8] 4th Lever Potentio (Main & Sub) Disagree	40-615
Failure code [DK5LKA] Failure of 4th Lever Potentio (Sub)	40-618
Failure code [DK5LKY] Hot Short of 4th Lever Potentio (Sub)	40-620
Failure code [DKA0KA] Failure of Boom Angle Sensor	40-622
Failure code [DKA0KY] Hot Short of Boom Angle Sensor Circuit	40-624
Failure code [DKA0L0] Boom Angle Sensor Dislocation	40-626
Failure code [DKA1KA] Failure of Bucket Angle Sensor	40-628
Failure code [DKA1KY] Hot Short of Bucket Angle Sensor Circuit	40-631
Failure code [DLF1KA] Disconnection of T/M Input Speed Sensor	40-633
Failure code [DLF1LC] Failure of T/M Input Speed Sensor	40-634
Failure code [DLM3KA] Disconnection of Radiator Fan Speed Sensor	40-635
Failure code [DLM3LC] Failure of Radiator Fan Speed Sensor	40-636
Failure code [DLT3KA] Disconnection of Output Speed Sens. (Main)	40-637
Failure code [DLT3LC] Failure of Output Speed Sensor (Main)	40-639
Failure code [DPQ1KR] LIN Discon (Switch Panel)	40-641
Failure code [DPQ2KR] LIN Discon (LED Unit)	40-644
Failure code [DPQ3KR] LIN Discon (Rear View Monitor)	40-647
Failure code [DSJ0KR] CAN2 Discon (Meter Unit)	40-650
Failure code [DT20KB] Ground Fault of T/M Cut Off Indicator	40-651
Failure code [DT22KB] Ground Fault of Work Equip. Lock Indic.	40-653
Failure code [DV00KB] Ground Fault of Buzzer Output	40-655
Failure code [DW4PKA] Disconnection of Boom EPC Solenoid (Raise)	40-657
Failure code [DW4PKB] Ground Fault of Boom EPC Solenoid (Raise)	40-658
Failure code [DW4PKY] Hot Short of Boom EPC Solenoid (Raise)	40-660
Failure code [DW4QKA] Disconnection of Boom EPC Solenoid (Lower)	40-662
Failure code [DW4QKB] Ground Fault of Boom EPC Solenoid (Lower)	40-663
Failure code [DW4QKY] Hot Short of Boom EPC Solenoid (Lower)	40-665
Failure code [DW4RKA] Disconnection of Bucket EPC Sol. (Tilt)	40-667
Failure code [DW4RKB] Ground Fault of Bucket EPC Solenoid (Tilt)	40-668
Failure code [DW4RKY] Hot Short of Bucket EPC Solenoid (Tilt)	40-670
Failure code [DW4SKA] Disconnection of Bucket EPC Sol. (Dump)	40-672
Failure code [DW4SKB] Ground Fault of Bucket EPC Solenoid (Dump)	40-673
Failure code [DW4SKY] Hot Short of Bucket EPC Solenoid (Dump)	40-675
Failure code [DW7BKA] Disconnection of Fan Reverse Solenoid	40-677
Failure code [DW7BKB] Ground Fault of Radiator Fan Rev. Sol.	40-678
Failure code [DW7BKY] Hot Short of Radiator Fan Rev. Sol.	40-679
Failure code [DWM1KA] Disconnection of Neutral Lock Solenoid	40-680

Failure code [DWM1KB] Ground Fault of Neutral Lock Solenoid.....	40-682
Failure code [DWM1KY] Hot Short of Neutral Lock Solenoid	40-684
Failure code [DWN6KA] Disconnection of Detent Solenoid (Boom)	40-686
Failure code [DWN6KB] Ground Fault of Detent Solenoid (Boom)	40-688
Failure code [DWN6KY] Hot Short of Detent Solenoid (Boom)	40-690
Failure code [DWN8KA] Disconnection of Detent Solenoid (Bucket).....	40-692
Failure code [DWN8KB] Ground Fault of Detent Solenoid (Bucket).....	40-694
Failure code [DWN8KY] Hot Short of Detent Solenoid (Bucket).....	40-696
Failure code [DX16KA] Disconnection of Rad. Fan Pump EPC Sol.....	40-698
Failure code [DX16KB] Ground Fault of Rad. Fan Pump EPC Sol.	40-699
Failure code [DX16KY] Hot Short of Radiator Fan Pump EPC Sol.	40-700
Failure code [DXA1KA] Disconnection of Loader Pump EPC Solenoid	40-701
Failure code [DXA1KB] Ground Fault of Loader Pump EPC Solenoid	40-702
Failure code [DXA1KY] Hot Short of Loader Pump EPC Solenoid	40-703
Failure code [DXANKA] Disconnection of Steering Pump EPC Sol.....	40-704
Failure code [DXANKB] Ground Fault of Steering Pump EPC Solenoid	40-705
Failure code [DXANKY] Hot Short of Steering Pump EPC Solenoid	40-706
Failure code [DXH1KA] Disconnection of ECMV Solenoid (Lockup)	40-707
Failure code [DXH1KB] Ground Fault of ECMV Solenoid (Lockup)	40-708
Failure code [DXH1KY] Hot Short of ECMV Solenoid (Lockup)	40-710
Failure code [DXH4KA] Disconnection of ECMV Solenoid (1st).....	40-712
Failure code [DXH4KB] Ground Fault of ECMV Solenoid (1st)	40-714
Failure code [DXH4KY] Hot Short of ECMV Solenoid (1st).....	40-716
Failure code [DXH5KA] Disconnection of ECMV Solenoid (2nd).....	40-718
Failure code [DXH5KB] Ground Fault of ECMV Solenoid (2nd)	40-719
Failure code [DXH5KY] Hot Short of ECMV Solenoid (2nd).....	40-721
Failure code [DXH6KA] Disconnection of ECMV Solenoid (3rd)	40-723
Failure code [DXH6KB] Ground Fault of ECMV Solenoid (3rd).....	40-724
Failure code [DXH6KY] Hot Short of ECMV Solenoid (3rd)	40-726
Failure code [DXH7KA] Disconnection of ECMV Solenoid (Reverse).....	40-728
Failure code [DXH7KB] Ground Fault of ECMV Solenoid (Reverse)	40-729
Failure code [DXH7KY] Hot Short of ECMV Solenoid (Reverse).....	40-731
Failure code [DXH8KA] Disconnection of ECMV Solenoid (Forward).....	40-733
Failure code [DXH8KB] Ground Fault of ECMV Solenoid (Forward).....	40-734
Failure code [DXH8KY] Hot Short of ECMV Solenoid (Forward).....	40-736
Failure code [DXHHKA] Disconnection of ECMV Solenoid (4th).....	40-738
Failure code [DXHHKB] Ground Fault of ECMV Solenoid (4th).....	40-739
Failure code [DXHHKY] Hot Short of ECMV Solenoid (4th).....	40-741
Failure code [DXHJKA] Disconnection of 3rd EPC Solenoid (EXT)	40-743
Failure code [DXHJKB] Ground Fault of 3rd EPC Solenoid (EXT).....	40-745
Failure code [DXHJKY] Hot Short of 3rd EPC Solenoid (EXT).....	40-747
Failure code [DXHKKA] Disconnection of 3rd EPC Solenoid (RET)	40-749
Failure code [DXHKKB] Ground Fault of 3rd EPC Solenoid (RET).....	40-751
Failure code [DXHKKY] Hot Short of 3rd EPC Solenoid (RET)	40-753
Failure code [DXJEKA] Disconnection of 4th EPC Solenoid (EXT)	40-755
Failure code [DXJEKB] Ground Fault of 4th EPC Solenoid (EXT).....	40-756
Failure code [DXJEKY] Hot Short of 4th EPC Solenoid (EXT)	40-757
Failure code [DXJFKA] Disconnection of 4th EPC Solenoid (RET)	40-759
Failure code [DXJFKB] Ground Fault of 4th EPC Solenoid (RET).....	40-760
Failure code [DXJFKY] Hot Short of 4th EPC Solenoid (RET)	40-761
Failure code [DY30MA] Malfunction 1 of Emerg. Steering Motor.....	40-763
Failure code [DY30MC] Malfunction 2 of Emerg. Steering Motor	40-765
Failure code [DY30ME] Emerg. Steering Long-Time Activated	40-768
Failure code [LA00L3] Failure of Fan Reverse	40-771
Troubleshooting of electrical system (E-mode)	40-772
E-1 Engine does not start.....	40-772
E-2 Wipers do not operate	40-777
E-3 Windshield washer does not operate	40-781

E-4 Headlamp, clearance lamp, tail lamp or license-plate lamp neither lights up nor goes out	40-784
E-5 Working lamp neither lights up nor goes out	40-790
E-6 Both turn signal lamp and emergency lamp neither lights up nor goes out	40-794
E-7 The stop lamp does not light up or stays lighted	40-800
E-8 Backup lamp does not light or continues to light	40-802
E-9 Backup buzzer does not sound or continues to sound	40-804
E-10 Horn does not sound or continues to sound	40-806
E-11 Alarm buzzer does not sound or does not stop sounding	40-808
E-12 Kickdown does not work when kickdown switch is turned ON	40-809
E-13 The hold switch does not work when it is pressed	40-811
E-14 Transmission is always shifted to Neutral, or the brake drags when parking brake applies and FR drive is selected	40-813
E-15 Transmission cut-off mode is not selected or not released	40-816
E-16 Transmission cut-off position cannot be released	40-818
E-17 FNR switch mode is not selected or not released	40-820
E-18 Flow of loader pump does not increase from the minimum rate	40-822
E-19 ECSS function cannot be selected or cannot be released	40-823
E-20 Parking brake indicator lamp does not light when the parking brake is set to ON (Parking) position	40-825
E-21 When brake accumulator oil pressure drops, the brake oil pressure caution lamp does not light	40-828
E-22 Air cleaner clogging indicator lamp does not light	40-831
E-23 Radiator coolant level caution lamp does not light	40-832
E-24 Indication of hydraulic oil temperature gauge does not increase, or hydraulic oil temperature caution lamp does not light	40-833
E-25 Indication of torque converter oil temperature gauge does not increase, or torque converter oil temperature caution lamp does not light	40-834
E-26 KOMTRAX system does not operate normally	40-835
Troubleshooting of hydraulic and mechanical system (H-mode)	40-836
Information mentioned in troubleshooting table (H-mode)	40-836
System chart of hydraulic and mechanical systems	40-837
Failure mode and cause table	40-839
H-1 Machine does not start	40-845
H-2 Torque converter lockup clutch is not disengaged (engine stalls)	40-848
H-3 Torque converter lockup clutch is not engaged	40-849
H-4 Travel speed is slow, bucket thrust force is weak, gradability is low, or gear speed does not shift	40-850
H-5 Large shock is made when machine starts or gear is shifted	40-853
H-6 Machine starts or gear speed shifts with long time lag	40-856
H-7 Torque converter oil temperature is high	40-858
H-8 Machine does not turn	40-861
H-9 Turning response is poor	40-863
H-10 Steering wheel is heavy to turn	40-865
H-11 Machine sways or large shocks are made while machine turns	40-866
H-12 Turning radius differs between right and left turns	40-868
H-13 Wheel brakes do not work or are weak	40-869
H-14 Wheel brakes are not released or drag	40-870
H-15 Parking brake does not work or it is weak	40-871
H-16 Parking brake is not released or drags (including emergency release system)	40-872
H-17 Boom does not rise	40-873
H-18 Boom moves slow or boom lacks lifting force	40-875
H-19 Rising boom slows down at certain height	40-877
H-20 Lift cylinders do not serve to hold bucket on ground	40-878
H-21 Hydraulic drift of boom is large	40-879
H-22 Boom moves up and down during operation	40-880
H-23 Bucket does not tilt back	40-881
H-24 Bucket moves slow or bucket lacks tilt-back force	40-883
H-25 Bucket decelerates during tilt-back operation	40-885

H-26 Bucket cylinder does not hold bucket on ground	40-886
H-27 Hydraulic drift of bucket is large	40-887
H-28 Bucket tilts back and forth during carrying load (work equipment valve in "HOLD").....	40-888
H-29 Boom and bucket control levers do not move smoothly and heavy to move	40-889
H-30 Operating work equipment causes engine speed to lower significantly or engine to stall	40-890
H-31 Large shocks are made when work equipment starts to move and stops	40-891
H-32 When certain work equipment stalls hydraulically, other work equipment moves	40-892
H-33 E.C.S.S. (travel damper) does not work and machine pitches and bounces	40-893
H-34 Air conditioner does not work while cooling fan rotates in reverse mode	40-894
H-35 Fan speed is abnormal (too high or low, or fan does not rotate)	40-895
H-36 Unusual noise is heard from around fan	40-896
Troubleshooting of engine (S-mode).....	40-897
Information described in troubleshooting table (S mode).....	40-897
S-1 Engine does not crank when starting switch is turned to "START" position	40-898
S-2 Engine cranks but no exhaust smoke comes out.....	40-899
S-3 Fuel is being injected but engine does not start (misfiring: engine cranks but does not start).....	40-900
S-4 Engine startability is poor	40-901
S-5 Engine does not pick up smoothly	40-903
S-6 Engine stops during operation	40-905
S-7 Engine runs rough or is unstable	40-907
S-8 Engine lacks power	40-908
S-9 Exhaust smoke is black (KDPF gets clogged in a short time)	40-910
S-10 Engine oil consumption is excessive	40-912
S-11 Oil becomes contaminated quickly	40-913
S-12 Fuel consumption is excessive	40-914
S-13 Oil is in coolant (or coolant spurts back or coolant level goes down).....	40-915
S-14 Oil pressure drops	40-916
S-15 Fuel mixes into engine oil	40-917
S-16 Water mixes into engine oil (milky)	40-918
S-17 Coolant temperature rises too high (overheating)	40-919
S-18 Unusual noise is heard	40-920
S-19 Vibration is excessive	40-921
S-20 Air cannot be bled from fuel circuit	40-922
S-21 Active regeneration is executed frequently	40-923
S-22 Active regeneration takes time.....	40-924
S-23 White smoke is exhausted during active regeneration	40-925
50 Disassembly and assembly	50-1
Table of contents	50-2
General information on disassembly and assembly.....	50-4
How to read this manual	50-4
Coating materials list	50-6
Special tools list	50-10
Sketches of special tools	50-13
Engine and cooling system	50-20
Removal and installation of supply pump assembly.....	50-20
Removal and installation of injector assembly.....	50-23
Removal and installation of cylinder head assembly.....	50-34
Removal and installation of engine hood assembly	50-53
Removal and installation of grille assembly	50-56
Removal and installation of cooling system assembly.....	50-57
Removal and installation of radiator core assembly	50-60
Removal and installation of aftercooler.....	50-63
Removal and installation of hydraulic oil cooler assembly	50-65
Removal and installation of fuel cooler assembly	50-66
Removal and installation of engine, torque converter and transmission assemblies	50-67

Removal and installation of engine front oil seal	50-76
Removal and installation of engine rear oil seal	50-79
Removal and installation of cooling fan and fan motor assembly	50-82
Removal and installation of KDPF assembly	50-84
Disassembly and assembly of KDPF assembly	50-87
Removal and installation of KCCV assembly	50-96
Removal and installation of air cleaner assembly	50-97
Removal and installation of fuel tank assembly	50-99
Power train	50-102
Disassembly and assembly of torque converter assembly	50-102
Disassembly and assembly of transmission assembly	50-109
Disassembly and assembly of transmission clutch pack assembly	50-122
Disassembly and assembly of differential assembly	50-136
Disassembly and assembly of parking brake assembly	50-154
Removal and installation of front axle assembly	50-162
Removal and installation of rear axle assembly	50-163
Disassembly and assembly of axle housing assembly	50-166
Steering system	50-175
Removal and installation of steering valve assembly	50-175
Brake system	50-177
Removal and installation of parking brake disc and plate	50-177
Undercarriage and frame	50-180
Removal and installation of center hinge pin	50-180
Removal and installation of counterweight assembly	50-188
Removal and installation of full-length fender assembly	50-190
Hydraulic system	50-191
Removal and installation of hydraulic tank assembly	50-191
Removal and installation of work equipment controll valve assembly	50-194
Removal and installation of power train pump and work equipment hydraulic pump assembly	50-197
Removal and installation of steering pump and cooling fan pump assembly	50-198
Disassembly and assembly of hydraulic cylinder assembly	50-200
Work equipment	50-207
Removal and installation of work equipment assembly	50-207
Cab and its attachments	50-212
Removal and installation of operator's cab and floor frame assembly	50-212
Removal and installation of operator's cab glass (stuck window glass)	50-216
Removal and installation of operator's seat assembly	50-224
Removal and installation of seat belt	50-226
Electrical system	50-227
Removal and installation of machine monitor assembly	50-227
Removal and installation of engine controller assembly	50-228
Removal and installation of work equipment controller assembly	50-229
Removal and installation of transmission controller assembly	50-231
Removal and installation of monitor controller assembly	50-232
Removal and installation of mass air flow and temperature sensor	50-234
Removal and installation of KOMTRAX terminal assembly	50-235
60 Maintenance standard	60-1
Table of contents	60-2
Engine and cooling system	60-3
Engine related parts	60-3
Cooling fan pump	60-4
Cooling fan motor	60-7
Power train	60-9
Drive shaft	60-9
Torque converter	60-10
Transmission	60-12
Transmission control valve	60-19
Forward and reverse clutch ECMV and gear speed clutch ECMV	60-20

Lockup clutch ECMV	60-21
Main relief and torque converter relief valve	60-22
Differential	60-23
Limited slip differential	60-25
Final drive	60-29
Steering system	60-31
Steering column	60-31
Steering pump	60-32
Steering valve	60-36
Steering cylinder	60-38
Emergency steering pump	60-40
Brake system	60-41
Charge valve	60-41
Brake	60-43
Parking brake	60-45
Parking brake solenoid valve	60-46
Undercarriage and frame	60-47
Axle mount and center hinge pin	60-47
Hydraulic system	60-51
Hydraulic tank	60-51
Double type gear pump	60-52
Work equipment pump	60-53
Control valve	60-58
Stabilizer valve	60-69
Work equipment	60-70
Work equipment linkage	60-70
Bucket	60-72
Work equipment cylinder	60-73
80 Appendix	80-1
Table of contents	80-2
Air conditioner	80-3
Precautions for refrigerant	80-3
Air conditioner component	80-4
Configuration and function of refrigeration cycle	80-6
Outline of refrigeration cycle	80-7
Air conditioner unit	80-9
Dual pressure switch	80-14
Air conditioner controller	80-15
Compressor	80-16
Condenser	80-17
Receiver drier	80-18
Sunlight sensor	80-20
Outer temperature sensor (outside air temperature sensor)	80-21
Procedure for testing and troubleshooting	80-22
Circuit diagram and arrangement of connector pins	80-24
System diagram	80-26
Parts and connectors layout	80-28
Testing with self-diagnosis function	80-33
How to enter air conditioner "Electrical Systems" screen in service mode of the machine monitor	80-34
Testing temperature control system	80-36
Testing vent (mode) changeover	80-38
Testing FRESH/RECIRC air changeover	80-40
Testing relays	80-42
Troubleshooting chart 1	80-43
Troubleshooting chart 2	80-44
Information mentioned in troubleshooting table	80-46
Troubleshooting with gauge pressure	80-47
Connection of service tool	80-50

00 Index and foreword

Index

Precautions for disconnecting and connecting hoses and tubes in air conditioner circuit.....	80-52
Handling of compressor oil.....	80-54
90 Diagrams and drawings	90-1
Table of contents	90-2
Hydraulic circuit diagram	90-3
Symbols in hydraulic circuit diagram	90-3
Power train hydraulic circuit diagram.....	90-6
Hydraulic circuit diagram.....	90-7
Electric circuit diagram	90-9
Symbols in electric circuit diagram	90-9
Electric circuit diagram of machine body.....	90-13
Electric circuit diagram of floor.....	90-23
Electric circuit diagram for air conditioner unit	90-39
Index.....	1

Foreword, safety and general information

Important safety notice

(Rev. 2011/02)

- Appropriate servicing and repair are extremely important to ensure safe operation of the machine. The Shop Manual describes the effective and safe servicing and repair methods recommended by Komatsu. Some of these methods require the use of special tools designed by Komatsu for the specific purpose.
- The symbol mark  is used for such matters that require special precautions during the work. The work indicated with the warning mark should be performed according to the instructions with special attention to the precautions. Should a hazardous situation occur or be anticipated during such work, be sure to keep safe first and take every necessary measure.

General precautions

 **Inappropriate handling creates an extreme danger. Read and understand what is described in the Operation and Maintenance Manual before operating the machine. In addition read this manual carefully and understand its contents before starting work.**

- Before performing any greasing or repairs, read all the safety labels stuck to the machine. For the locations of the safety labels and detailed explanation of precautions, see the Operation and Maintenance Manual.
- Locate a place in the repair workshop to keep tools and removed parts. Always keep the tools and parts in their correct places. Always keep the work area clean and make sure that there is no dirt, water, or oil on the floor. Smoke only in the areas provided for smoking. Never smoke while working.
- When performing any work, always wear safety shoes and helmet. Do not wear loose work clothes, or clothes with buttons missing.
 1. Always wear the protective eyeglasses when hitting parts with a hammer.
 2. Always wear the protective eyeglasses when grinding parts with a grinder, etc.
- When performing any work with two or more workers, always agree on the operating procedure before starting. Always inform your fellow workers before starting any step of the work. During the work, hang UNDER REPAIR warning tag in the operator's compartment.
- Only qualified workers must perform the work and operation which require license or qualification.
- Keep all tools in good condition. Learn the correct way to use them, and use the proper ones of them. Before starting work, thoroughly check the tools, machine, forklift truck, service car, etc.
- If welding repairs are needed, always have a trained and experienced welder perform the

work. When performing welding work, always wear welding gloves, apron, shielding goggles, cap and other clothes suited for welding work.

- Before starting work, warm up your body thoroughly to start work under good condition.
- Avoid continuing work for long hours and take rests at proper intervals to keep your body in good condition. Take rests in specified safe places.

Safety points

1	Good arrangement
2	Correct work clothes
3	Following work standard
4	Making and checking signals
5	Prohibition of operation and handling by unlicensed workers
6	Safety check before starting work
7	Wearing protective goggles (for cleaning or grinding work)
8	Wearing shielding goggles and protectors (for welding work)
9	Good physical condition and preparation
10	Precautions against work which you are not used to or you are used to too much

Preparation work

- Before adding oil or making any repairs, park the machine on a hard and level ground, and apply the parking brake and chock the wheels or tracks to prevent the machine from moving.
- Before starting work, lower the work equipment (blade, ripper, bucket, etc.) to the ground. If this is not possible, insert the lock pin or use blocks to prevent the work equipment from falling. In addition, be sure to lock all the control levers and hang warning tag on them.
- When disassembling or assembling, support the machine with blocks, jacks, or stands before starting the work.
- Remove all mud and oil from the steps or other places used to get on and off the machine. Always use the handrails, ladders or steps when getting on or off the machine. Never jump on or

00 Index and foreword

Foreword, safety and general information

off the machine. When a scaffolding is not provided, use steps or a step ladder to secure your footing.

Precautions during work

- For the machine equipped with a battery disconnect switch, before starting the work, check that the system operating lamp is turned OFF, and then turn the battery disconnect switch to the OFF (○) position and pull the switch key out. For machines without a battery disconnect switch, before starting the work, remove the cables from the battery. Always remove the cable from the negative (–) terminal first.
- Before disconnecting or removing components of the oil, water, or air circuits, first release the remaining pressure completely from the circuit. When removing the oil filter cap, a drain plug, or an oil pressure pickup plug, loosen it slowly to prevent the oil from spurting out.
- The coolant and oil in the circuits are hot when the engine is shut down. Be careful not to get scalded. Wait for the oil and coolant to cool before performing any work on the oil or water circuits.
- Before starting work, shut down the engine. When working on or around a rotating part, in particular, shut down the engine. When checking the machine without stopping the engine (measuring oil pressure, revolving speed, temperature, etc.), take extreme care not to get rolled or caught in rotating parts or moving parts.
- When raising a heavy component (heavier than 25 kg), use a hoist or crane. Before starting work, check that the slings (wire ropes, chains, and hooks) are free from damage. Always use slings which have ample capacity and install them to proper places. Operate the hoist or crane slowly to prevent the component from hitting any other part. Do not work with any part still raised by the hoist or crane.
- When removing a cover which is under internal pressure or under reaction force of a spring, always leave two bolts in diagonal positions. Loosen those two bolts gradually and alternately to release the pressure, and then remove the cover.
- When removing components, be careful not to break or damage the electrical wiring. Damaged wiring may cause electrical fires.
- When removing piping, stop the fuel or oil from spilling out. If any fuel or oil drips onto the floor, wipe it off immediately. Fuel or oil on the floor can cause you to slip and can even cause fires.
- As a general rule, do not use gasoline to wash parts. Do not use it to clean electrical parts, in particular.
- Be sure to assemble all parts again in their original places. Replace any damaged parts and parts which must not be reused with new parts. When installing hoses and wires, be sure that they will not be damaged by contact with other parts when the machine is operated.
- When installing high pressure hoses and tubes, make sure that they are not twisted. Damaged hoses and tubes are dangerous, so be extremely careful when installing hoses and tubes for high-pressure circuits. In addition, check that connections of them are correct.
- When assembling or installing parts, always tighten them to the specified torques. When installing protective parts such as guards, or parts which vibrate violently or rotate at high speeds, be particularly careful to check that they are installed correctly.
- When aligning two holes, never insert your fingers or hand. Be careful not to get your fingers caught in a hole.
- When measuring hydraulic pressure, check that the measuring tools are correctly installed.
- Take care when removing or installing the tracks of track-type machines. When removing the track, the track separates suddenly, so never let anyone stand at either end of the track.
- If the engine is operated for a long time in a place which is not ventilated well, you may suffer from gas poisoning. Accordingly, open the windows and doors to ventilate well.

Precautions for slinging work and making signals

- Only one appointed worker must make signals and co-workers must communicate with each other frequently. The appointed signaler must make specified signals clearly at a place where he (she) is well seen from the operator's seat and where he (she) can see the working condition easily. The signaler must always stand in front of the load and guide the operator safely.
 1. Do not stand under the load.
 2. Do not step on the load.
- Check the slings before starting sling work.
- Keep putting on gloves during sling work. (Put on leather gloves, if available.)
- Measure the weight of the load by the eye and check its center of gravity.
- Use proper sling according to the weight of the load and method of slinging. If too thick wire ropes are used to sling a light load, the load may slip and fall.
- Do not sling a load with one wire rope alone. If it is slung by one wire rope, it may rotate and slip out of the rope. Install two or more wire ropes symmetrically.

⚠ Slinging with one rope may cause turning of the load during hoisting, untwisting of the rope, or slipping of the rope from its original winding position on the load, which can result in a dangerous accident.

- Limit the hanging angle to 60 degrees, as a rule.
- Do not sling a heavy load (25 kg or more) with ropes forming a wide hanging angle from the hook.
- ★ When hoisting a load with two or more ropes, the force subjected to each rope will increase with the hanging angle. The figure below shows the variation of allowable load in kN {kg} when hoisting is made with two ropes, each of which is allowed to sling up to 9.8 kN {1,000 kg} vertically, at various hanging angles. When the two ropes sling a load vertically, up to 19.6 kN {2,000 kg} of total weight can be suspended. This weight is reduced to 9.8 kN {1,000 kg} when the two ropes make a hanging angle of 120 degrees. If the two ropes sling a 19.6 kN {2,000 kg} load at a lifting angle of 150 degrees, each rope is subjected to a force as large as 39.2 kN {4,000 kg}.

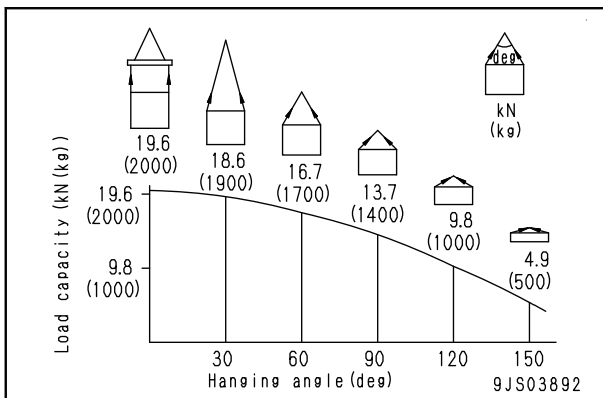

- When installing wire ropes to an angular load, apply pads to protect the wire ropes. If the load is slippery, apply proper material to prevent the wire rope from slipping.
- Use the specified eyebolts and fix wire ropes, chains, etc. to them with shackles, etc.
- Apply wire ropes to the middle portion of the hook.
- ★ Slinging near the tip of the hook may cause the rope to slip off the hook during hoisting. The hook has the maximum strength at the middle part.

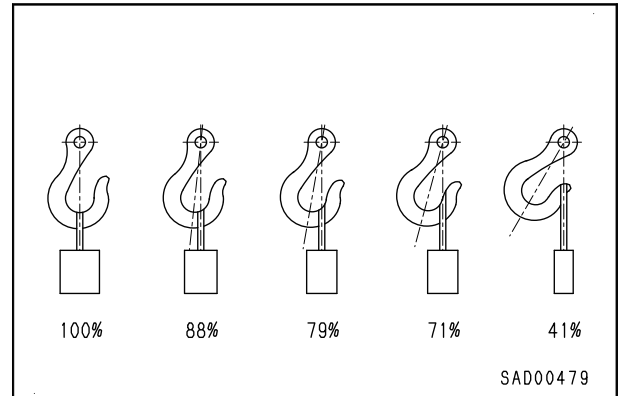

- Do not use twisted or kinked wire ropes.
- When lifting up a load, observe the following.
 1. Wind in the crane slowly until wire ropes are stretched. When settling the wire ropes with the hand, do not grasp them but press them from above. If you grasp them, your fingers may be caught.
 2. After the wire ropes are stretched, stop the crane and check the condition of the slung load, wire ropes, and pads.
 3. If the load is unstable or the wire rope or chains are twisted, lower the load and lift it up again.
 4. Do not lift up the load at an angle.
- When lowering a load, observe the following.
 1. When lifting down a load, stop it temporarily at 30 cm above the floor, and then lower it slowly.
 2. Check that the load is stable, and then remove the sling.
 3. Remove kinks and dirt from the wire ropes and chains used for the sling work, and put them in the specified place.

Precautions for using mobile crane

- ★ Read the Operation and Maintenance Manual of the crane carefully in advance and operate the crane safely.

Precautions for using overhead traveling crane

⚠ When raising a heavy part (heavier than 25 kg), use a hoist, etc. . In disassembly and assembly, the weight of a part heavier than 25 kg is indicated after the mark of .

- Before starting work, inspect the wire ropes, brake, clutch, controller, rails, over wind stop device, ground fault circuit interrupter, crane collision prevention device, and power application warning lamp, and check safety.
- Observe the signals for sling work.
- Operate the hoist at a safe place.
- Check the direction indicator plates (north, south, east, and west) and the directions of the control buttons without fail.

00 Index and foreword

Foreword, safety and general information

- Do not sling a load at an angle. Do not move the crane while the slung load is swinging.
- Do not raise or lower a load while the crane is moving longitudinally or laterally.
- Do not drag a sling.
- When lifting up a load, stop it just after it leaves the ground and check safety, and then lift it up.
- Consider the travel route in advance and lift up a load to a safe height.
- Place the control switch in a position where it will not be an obstacle to work and passage.
- After operating the hoist, do not swing the control switch.
- Remember the position of the main switch so that you can turn off the power immediately in an emergency.
- If the hoist stops because of a power failure, turn the power switch OFF. When turning on a switch which was turned OFF by the ground fault circuit interrupter, check that the devices related to that switch are not in operating condition.
- If you find an obstacle around the hoist, stop the operation.
- After finishing the work, stop the hoist at the specified position and raise the hook to at least two meters above the floor. Do not leave the sling attached to the hook.

Selecting wire ropes

- Select adequate ropes depending on the weight of parts to be hoisted, referring to the table below

Wire ropes (standard "Z" twist ropes without galvanizing) (JIS G3525, No. 6, Type 6x37-A)

Nominal diameter of rope	Allowable load	
	kN	ton
mm		
10	8.8	0.9
12	12.7	1.3
14	17.3	1.7
16	22.6	2.3
18	28.6	2.9
20	35.3	3.6
25	55.3	5.6
30	79.6	8.1
40	141.6	14.4
50	221.6	22.6
60	318.3	32.4

- ★ The allowable load is one-sixth of the breaking strength of the rope to be used (Safety coefficient: 6).

Precautions for disconnecting and connecting hoses and tubes in air conditioner circuit

Disconnection

⚠ Disconnection although the refrigerant (refrigerant gas: R134a) used on the machine's air conditioner is less destructive to the ozone layer for environmental friendliness, it is not allowed to be released into the atmosphere as is. Whenever disconnecting the air conditioner gas circuit, be sure to recover the refrigerant gas to reuse it.

- ★ Ask a qualified person for collection, and charge of the refrigerant (R134a).
- ★ Never release the refrigerant (R134a) to the atmosphere.

⚠ If refrigerant gas (R134a) gets in your eyes, you may lose your sight. And if it touches your skins, you may suffer from frostbite. Accordingly, put on protective eyeglasses, gloves and working suits with long sleeves while you are collecting or filling the refrigerant (R134a).

- When loosening the nuts fixing air conditioner hoses and tubes, be sure to use two wrenches; use one wrench to fix and use the other one to loosen the nut.

Connection

- When installing the air conditioner hoses and tubes, take care to prevent any dirt, dust or water from entering.
- When installing the air conditioner hoses and tubes, check that O-rings are fitted to their joints.
- Once an O-ring is used, it is deformed and deteriorated. Accordingly, do not reuse it.
- When removing O-rings, use a soft tool so that the piping will not be damaged.
- Check that there is no defect or deterioration on the O-ring.
- Apply compressor oil for refrigerant (R134a) to the O-ring.
 - ★ However, do not apply oil to the threads portion of a bolt, nut or union.

Manufacturer	Part name
DENSO	ND-OIL8
VALEO THERMAL SYSTEMS	ZXL100PG (equivalent to PAG46)
SANDEN	SP-10

- When tightening nuts of the air conditioner hoses and tubes, be sure to use two wrenches. Use one wrench to fix and tighten the nut with

the other wrench to the specified torque (Use a torque wrench for tightening).

★ Example of fitting of O-ring

- An O-ring is fitted to every joint of hoses and tubes in the air conditioner circuit.

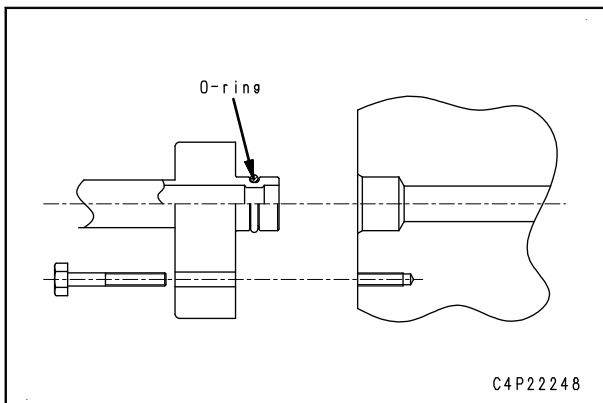
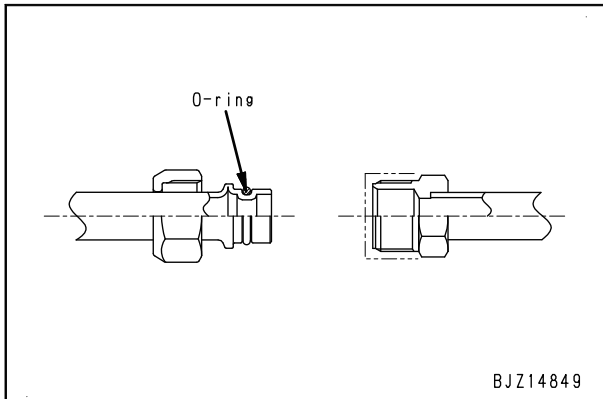

- ★ For tightening torques, see "Others",
"Precautions for disconnection and connection
of air conditioner piping".

Fire prevention

Action if fire occurs

- Turn the start switch OFF to stop the engine.
- Use the handrails and steps to get off the machine.
- Do not jump off the machine. There is the danger of falling and suffering serious injury.
- When the machine is involved with a fire, fumes include harmful materials.
Don't breathe the fumes.
- After a fire, there might be harmful material left. Don't touch them directly, because they might be harmful to person.
Anyone conducting clean-up must wear rubber groves.
Rubber gloves should be polychloroprene (Neoprene) or polyvinyl chloride (in the case of low temperature).
When wearing cotton-work-gloves, wear rubber gloves under them.

Prevent fire

- **Fire caused by fuel, oil, coolant, or window washer fluid**
Do not bring any flame or fire close to flammable substances such as fuel, oil, coolant, or window washer fluid. There is danger that they may catch fire. To prevent fire, always observe the following.
 - Do not smoke or use any flame near fuel or other flammable substances.
 - Stop the engine before adding fuel.
 - Do not leave the machine when adding fuel or oil.
 - Tighten all fuel and oil caps securely.
 - Be careful not to spill fuel on overheated surfaces or on parts of the electrical system.
 - After adding fuel or oil, wipe up any spilled fuel or oil.
 - Put greasy rags and other flammable materials into a safe container to maintain safety at the workplace.
 - When washing parts with oil, use a non-flammable oil. Do not use diesel oil or gasoline. There is danger that they may catch fire.
 - Do not weld or use a cutting torch to cut any pipes or tubes that contain flammable liquids.
 - Determine well-ventilated areas for storing oil and fuel. Keep the oil and fuel in the determined place and do not allow unauthorized persons to enter.
 - When carrying out grinding or welding work on the machine, move any flammable materials to a safe place before starting.

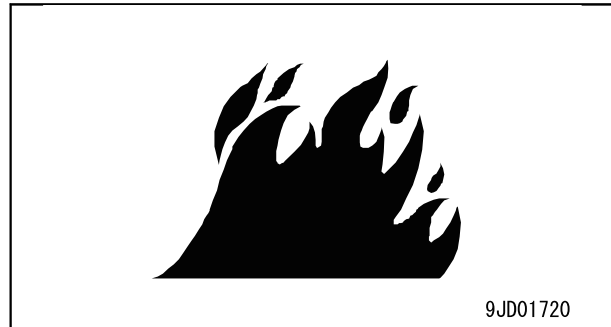

- **Fire caused by accumulation of flammable material**
 - Remove any dry leaves, chips, pieces of paper, coal dust, or any other flammable materials accumulated or affixed around the engine exhaust manifold, muffler or battery, or inside the undercovers.
 - To prevent fires spreading from sparks or burning particles from other fires, remove any flammable materials such as dry leaves, chips, coal dust, or any other flammable materials accumulated around the cooling system (radiator, oil cooler) or inside the undercover.
- **Fire coming from electric wiring**
Short circuits in the electrical system can cause fire. To prevent fire, always observe the following.
 - Keep all electric wiring connections clean and securely tightened.
 - Check the wiring every day for looseness or damage. Tighten any loose connectors or wiring clamps. Repair or replace any damaged wiring.
- **Fire coming from piping**
Check that all the hose and tube clamps, guards, and cushions are securely fixed in position. If they are loose, they may vibrate during operation and rub against other parts. There is danger that this may lead to damage to the hoses and cause high-pressure oil to spurt out, leading to fire, serious personal injury or death.
- **Fire around the machine due to highly heat exhaust gas**
This machine is equipped with KDPF (Komatsu Diesel Particulate Filter).
KDPF is a system for purifying soot in exhaust gas. Its exhaust gas discharged during

purification process (regeneration) can be at higher temperature than that from existing models. Do not bring any flammable close the outlet of the exhaust pipe.

- When there are thatched houses, dry leaves or pieces of paper near the work site, set the system to disable the regeneration before starting work to prevent fire hazards due to highly heated exhaust gas.
For the setting procedure, see the Operation and Maintenance Manual.

- **Explosion caused by lighting equipment**

- When checking fuel, oil, battery electrolyte, or coolant, always use lighting with anti-explosion specifications.
- When taking electrical power for the lighting from the machine itself, see the Operation and Maintenance Manual.

Dispose of waste materials

To prevent pollution, pay careful attention to the method of disposing of waste materials.

- Always put oil drained from your machine in containers. Never drain oil directly onto the ground or dump into the sewage system, rivers, the sea, or lakes.
- Obey appropriate laws and regulations when disposing of harmful objects such as oil, fuel, coolant, solvent, filters, and batteries.

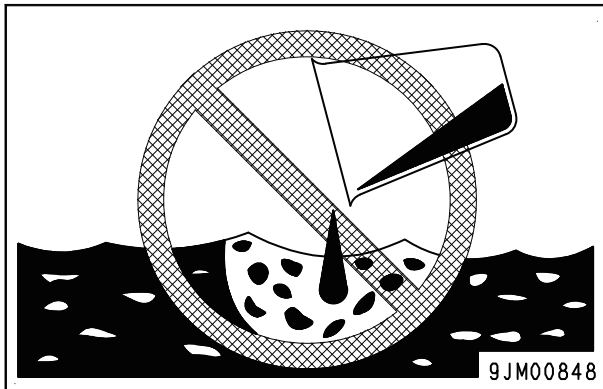

Some kinds of rubber, plastics might produce poisonous gas harmful to person, when they are burned.

- When disposing of rubber, plastics, or parts (hoses, cables, and harness) made of those materials, these must be treated by industrial waste disposer in accordance with local regulations.

How to read the shop manual

(Rev. 2011/06)

- Some attachments and optional parts in this shop manual may not be delivered to certain areas. If one of them is required, consult KOMATSU distributors.
- Materials and specifications are subject to change without notice.
- Shop manuals are divided into the "Chassis volume" and "Engine volume". For the engine unit, see the engine volume of the engine model mounted on the machine.

Composition of shop manual

- This shop manual contains the necessary technical information for services performed in a workshop. For ease of understanding, the manual is divided into the following sections.

00. Index and foreword

- This section contains the index, foreword, safety and basic information. If any revision is made, the LIST OF REVISED PAGES will be added.

01. Specification

- This section explains the specifications of the machine.

10. Structure and function

- This section explains the structure and function of each component. It serves not only to give an understanding for the structure of each component, but also serves as reference material for troubleshooting.

20. Standard value table

- This section explains the standard values for new machine and judgement criteria for testing, adjusting, and troubleshooting. This standard value table is used to check the standard values in testing and adjusting and to judge parts in troubleshooting.

30. Testing and adjusting

- This section explains measuring tools and measuring methods for testing and adjusting, as well as the adjusting method of each part. The standard values and judgment criteria for "Testing and adjusting" are explained in "Standard value table".

40. Troubleshooting

- This section explains how to find out failed parts and how to repair them. The troubleshooting is divided by failure modes.

50. Disassembly and assembly

- This section explains the special tools and procedures for removing, installing, disassembling, and assembling each component, as well as precautions for them. In addition, tightening torque, and quantity and weight of coating material, oil, grease, and coolant necessary for the work are also explained.

60. Maintenance standard

- This section gives maintenance standard values of each component. The maintenance standard sub-section explains the criteria and remedies for disassembly and service.

80. Appendix

- The section contains the equipment which can not be class, field in the other sections. This section explains the structure, function, testing, adjusting, and troubleshooting for the equipment.

90 Diagrams and drawings

- This section gives hydraulic circuit diagrams and electrical circuit diagrams.





Revision and distribution

- Any additions, revisions, or other change of notices will be sent to KOMATSU distributors. Get the most up-to-date information before you start any work.

Symbol

Important safety and quality portions are marked with the following symbols so that the shop manual will be used practically.

Symbol	Item	Description
	Safety	Special safety precautions which are necessary when performing work are described.
★	Caution	Special technical precautions or other precautions for preserving standards which are necessary when performing work are described.

Symbol	Item	Description
	Weight	Weight of parts of component or parts are indicated. Caution necessary when selecting hoisting wire, or when working posture is important, etc. are described.
	Tightening torque	Tightening torque of the places that requires special attention.
	Coat	Places to be coated with adhesives, etc. during assembly are indicated.
	Oil, coolant	Places where oil, etc. must be added, and capacity are indicated.
	Drain	Places where oil, etc. must be drained, and quantity to be drained are indicated.

Unit

- In this shop manual, the units are indicated with International System of units (SI).
- For reference, conventionally used Gravitational System of units is indicated in parentheses { }.

Explanation of terms for maintenance standard

(Rev. 2011/02)

- The maintenance standard chapter describes the criteria for replacing or reusing products or parts in the machine disassembly and maintenance work. The following terms are used to describe the criteria.

Standard dimension and tolerance

- To be accurate, the finished dimension of parts is slightly different from one to another.
- To specify the finished dimension of a part, a certain dimension is set for the part and an allowable difference from that dimension is indicated.
- The above dimension set is called the "standard dimension" and the range of difference from the standard dimension is called the "tolerance".
- The tolerance with the symbols of + or - is indicated on the right side of the standard dimension.

Example:

Standard dimension	Tolerance
120	-0.022
	-0.126

- The tolerance may be indicated in the text and a table as "standard dimension (upper limit of tolerance/lower limit of tolerance)." Example) 120 (-0.022/-0.126)
- Usually, the dimension of a hole and the dimension of the shaft to be inserted into that hole are indicated by the same standard dimension and different tolerances of the hole and shaft. The tightness of fit is decided by the tolerance.
- Indication of dimension of rotating shaft and hole and their related drawing.

Example:

Standard dimension	Tolerance	
	Shaft	Hole
60	-0.030	+0.046
	-0.076	0

Standard clearance and standard value

- The clearance made when new parts are assembled is called the standard clearance, which is indicated by the range from the minimum clearance to the maximum clearance.
- When some parts are repaired, the clearance is generally adjusted to the standard clearance.
- The values indicating performance and function of new products or equivalent are called the "standard value", which is indicated by a range or a target value.
- When some parts are repaired, the value of performance/function is set to the standard value.

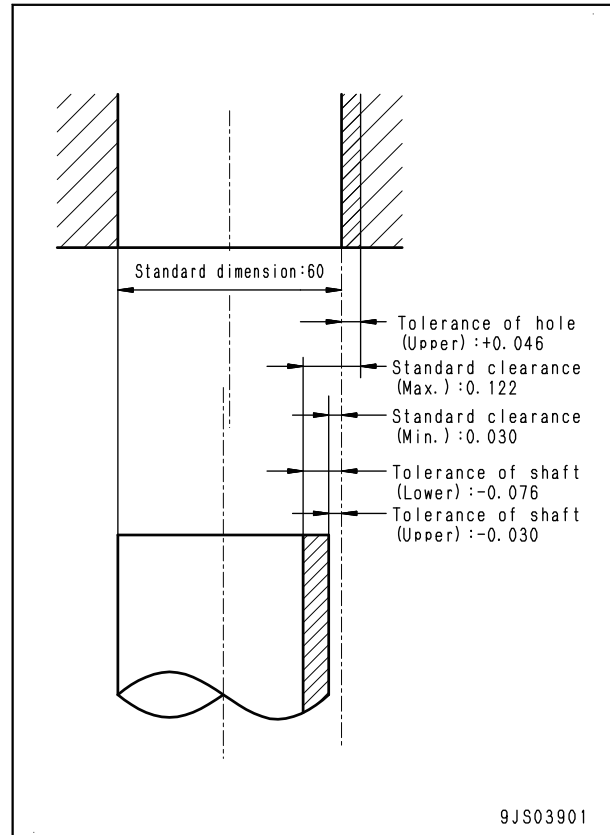

Standard interference

- When the diameter of a hole of a part shown in the given standard dimension and tolerance table is smaller than that of the shaft to be inserted, the difference between those diameters is called the "interference".
- Subtract the maximum dimension of the hole from the minimum dimension of the shaft and call it (A). Subtract the minimum dimension of the hole from the maximum dimension of the shaft and call it (B). The range between (A) and (B) is the "standard interference".
- After repairing or replacing some parts, measure the dimension of their hole and shaft and check that the interference is in the standard range.

Repair limit and allowable value or allowable dimension

- The dimension of parts changes due to the wear or deformation while they are used. When the dimension changes exceeding certain value, parts can not be used any longer. This value is called the "repair limit".
- If a part is worn to the repair limit, it must be replaced or repaired.

- The performance and function of products lowers while they are used. When alternative characteristic value of the performance and function towers exceeding certain limit, it fluence operation etc. This value is called the allowable value or allowable dimension
- If a product deviates from the allowable value, it must be checked or repaired. However, since the allowable values are generally estimated from various tests or experiences in most cases, it must be judged after considering the operating condition and customer's requirement.

Allowable clearance

- Parts can be used until the clearance between them is increased to a certain limit. The limit at which those parts cannot be used is called the "allowable clearance".
- If the clearance between the parts exceeds the allowable clearance, they must be replaced or repaired.

Allowable interference

- The allowable maximum interference between the hole of a part and the shaft of another part to be assembled is called the "allowable interference".
- The allowable interference shows the repair limit of the part of smaller tolerance.
- If the interference between the parts exceeds the allowable interference, they must be replaced or repaired.



Download the full PDF manual instantly.

Our customer service e-mail:

aservicemanualpdf@yahoo.com