

# Shop Manual

WHEEL LOADER

**WA320 -6**

**WA320PZ-6**

SERIAL NUMBERS

WA320- 70001

WA320PZ- 70001

and up

**ecot3**

**KOMATSU**

## Table of contents

00 Index and foreword	
100 Index	SEN04171-07
Composition of shop manual.....	2
Table of contents.....	4
200 Foreword and general information	SEN04172-01
Safety notice.....	2
How to read the shop manual.....	7
Explanation of terms for maintenance standard.....	9
Handling of electric equipment and hydraulic component.....	11
Handling of connectors newly used for engines.....	20
How to read electric wire code.....	23
Precautions when carrying out operation.....	26
Method of disassembling and connecting push-pull type coupler.....	29
Standard tightening torque table.....	32
Conversion table.....	36
01 Specification	
100 Specification and technical data	SEN04173-01
Specification dimension drawing.....	3
Specifications.....	4
Weight table.....	8
Table of fuel, coolant and lubricants.....	10
10 Structure, function and maintenance standard	
100 Engine and cooling system	SEN04174-01
Engine mount and transfer mount.....	2
Damper.....	3
Cooling system.....	4
Cooling system hydraulic piping diagram.....	5
Cooling fan motor.....	7
200 Power train	SEN04175-01
Power train.....	3
Power train system diagram.....	4
Drive shaft.....	6
HST hydraulic piping diagram.....	7
HST pump.....	8
HST motor.....	16
Transfer.....	22
Clutch solenoid valve.....	33
Axle.....	34
Differential.....	36
Torque proportioning differential.....	41
Limited slip differential.....	44
Final drive.....	48
300 Steering system	SEN04176-01
Steering piping diagram.....	3
Steering column.....	4
Priority valve.....	5
Orbit-roll valve.....	8
Cushion valve.....	16
Steering cylinder.....	17
Emergency steering piping diagram.....	19
Emergency steering valve.....	20
Steering relief valve.....	23

400 Brake system	SEN04177-00
Brake piping diagram.....	3
Charge valve .....	4
Brake valve.....	8
Inching valve.....	12
Accumulator (for brake) .....	13
Slack adjuster .....	14
Brake .....	16
Parking brake control.....	21
Parking brake .....	22
500 Undercarriage and frame	SEN04178-00
Axle mount and center hinge pin .....	2
Tires.....	7
600 Hydraulic system	SEN04179-00
Work equipment hydraulic piping diagram .....	2
Work equipment control lever linkage .....	6
Hydraulic tank.....	10
4-gear pump .....	12
Work equipment control valve .....	14
Cut-off valve .....	40
PPC valve.....	43
Lock valve.....	58
Accumulator (for PPC circuit) .....	59
ECSS valve .....	61
Accumulator (for ECSS) .....	63
700 Work equipment	SEN04180-02
Work equipment linkage .....	2
Bucket.....	6
Bucket positioner and boom kick-out.....	10
Work equipment cylinder .....	22
800 Cab and its attachments	SEN04181-00
Cab.....	3
Air conditioner.....	4
910 Electrical system, Part 1	SEN04182-02
Machine monitor system.....	2
Machine monitor .....	6
920 Electrical system, Part 2	SEN04183-03
Electrical system (HST controller system).....	2
HST controller.....	18
ECSS system .....	20
KOMTRAX system .....	22
Engine starting circuit .....	24
Engine stopping circuit .....	26
Preheating circuit.....	27
Engine output derating function.....	28
Automatic warm-up function .....	28
Parking brake circuit .....	30
Coupler plunger control system.....	32
Max. traction switch .....	33
Multi-function knob .....	34
Sensor .....	35
20 Standard value table	
100 Standard service value table	SEN04184-00
Standard service value table for engine .....	2
Standard service value table for chassis .....	3

30 Testing and adjusting	
110 Testing and adjusting, Part 1	SEN04185-03
Tools for testing, adjusting, and troubleshooting .....	3
Measuring engine speed .....	8
Measuring exhaust gas color .....	10
Adjusting valve clearance .....	12
Measuring compression pressure .....	14
Measuring blow-by pressure .....	17
Measuring engine oil pressure .....	18
Measuring intake air (boost) pressure .....	19
Handling fuel system equipment .....	21
Releasing residual pressure in fuel system .....	21
Measuring fuel pressure .....	22
Measuring fuel return rate and leakage .....	24
Bleeding air from fuel circuit .....	28
Checking leakage in fuel system .....	29
Handling cylinder cut-out mode operation .....	30
Handling no-injection cranking operation .....	30
Handling controller voltage circuit .....	31
Check of muffler and muffler stack for looseness and damage .....	31
Check of muffler function .....	32
Check of installed condition of cylinder head and manifolds .....	32
Check of engine piping for damage and looseness .....	33
Testing and adjusting air conditioner compressor belt tension .....	33
Replacing alternator belt .....	34
120 Testing and adjusting, Part 2	SEN04186-04
Checking operating force of accelerator pedal .....	3
Checking directional lever .....	4
Testing and adjusting HST oil pressure .....	5
Testing clutch control pressure .....	9
Testing and adjusting steering wheel .....	10
Testing and adjusting steering oil pressure .....	12
Bleeding air from steering circuit .....	14
Testing hydraulic fan .....	15
Measuring brake pedal .....	17
Testing and adjusting brake pedal linkage .....	18
Measuring brake performance .....	19
Testing and adjusting accumulator charge pressure .....	20
Testing wheel brake oil pressure .....	22
Testing wear of brake disc .....	25
Bleeding air from wheel brake circuit .....	26
Releasing residual pressure in brake accumulator circuit .....	27
Testing parking brake performance .....	28
Testing and adjusting parking brake control cable .....	29
Measuring and adjusting work equipment control lever .....	30
Testing and adjusting work equipment hydraulic pressure .....	31
Testing work equipment PPC oil pressure .....	32
Bleeding air from hydraulic circuit .....	34
Releasing remaining pressure in hydraulic circuit .....	35
Testing and adjusting bucket positioner .....	36
Testing and adjusting of boom kick-out switch .....	37
Checking proximity switch operation pilot lamp .....	38
Procedure for testing diodes .....	39
Preparation work for troubleshooting for electric system .....	40
Starting KOMTRAX terminal operations .....	44
Indicator lamps of KOMTRAX terminal .....	48

130 Testing and adjusting, Part 3	SEN04187-02
Adjusting machine monitor .....	2
Adjusting replaced, reassembled or added sensor, controller, etc. with machine monitor .....	3
Special functions of machine monitor (EMMS).....	5
Pm clinic inspection chart .....	58
40 Troubleshooting	
100 Failure code table and fuse locations	SEN04188-02
Failure codes table .....	2
Fuse locations .....	8
200 General information on troubleshooting	SEN04189-02
Points to remember when troubleshooting .....	2
Sequence of events in troubleshooting .....	3
Testing before troubleshooting .....	4
Classification and procedures of troubleshooting.....	5
Information contained in troubleshooting table.....	8
Connection table for connector pin numbers.....	10
T- branch box and T- branch adapter table .....	46
310 Troubleshooting by failure code (Display of code), Part 1	SEN04190-00
Failure code [2G40ZG] Brake: Oil pressure reduction .....	2
Failure code [6091NX] HST filter: Clogging.....	4
Failure code [989FN1] Travel speed: Overrun alarm .....	5
Failure code [AA1ANX] Air cleaner: Clogging .....	6
Failure code [AB00L6] Alternator R system: Hot short.....	8
Failure code [AB00MA] Alternator R system: Ground fault/Disconnection/Low charge voltage .....	10
Failure code [B@BAZG] Engine: Oil pressure reduction.....	12
Failure code [B@BAZK] Engine oil: Low level.....	13
Failure code [B@BCNS] Engine: Overheat.....	14
Failure code [B@BCZK] Engine: Low coolant level .....	16
Failure code [B@C6NS] Front brake: High oil temperature .....	18
Failure code [B@CRNS] HST: High oil temperature .....	19
320 Troubleshooting by failure code (Display of code), Part 2	SEN04191-00
Failure code [CA111] Abnormality in engine controller .....	3
Failure code [CA115] Engine Ne or Bkup speed sensor error.....	4
Failure code [CA122] Charge pressure sensor high error.....	6
Failure code [CA123] Charge pressure sensor low error .....	8
Failure code [CA131] Throttle sensor high error .....	10
Failure code [CA132] Throttle sensor low error.....	12
Failure code [CA144] Coolant sensor high error .....	14
Failure code [CA145] Coolant sensor low error.....	16
Failure code [CA153] Charge temperature sensor high error .....	18
Failure code [CA154] Charge temperature sensor low error.....	20
Failure code [CA155] Derating of speed by abnormally high charge temperature.....	22
Failure code [CA187] Sensor power supply 2 low error .....	24
Failure code [CA221] Atmospheric pressure sensor high error.....	26
Failure code [CA222] Atmospheric sensor low error .....	28
Failure code [CA227] Sensor power supply 2 high error.....	30
Failure code [CA234] Engine overspeed.....	31
Failure code [CA238] Ne speed sensor power supply error.....	32
Failure code [CA271] IMV (IMA) Short circuit.....	33
Failure code [CA272] IMV (IMA) Disconnection .....	34
Failure code [CA322] Injector #1 open/short error .....	36
Failure code [CA323] Injector #5 open/short error .....	38
Failure code [CA324] Injector #3 open/short error .....	40
Failure code [CA325] Injector #6 open/short error .....	42
Failure code [CA331] Injector #2 open/short error .....	44
Failure code [CA332] Injector #4 open/short error .....	46

Failure code [CA342] Calibration code inconsistency .....	48
Failure code [CA351] Injectors drive circuit error .....	50
Failure code [CA352] Sensor power supply 1 low error .....	52
Failure code [CA386] Sensor power supply 1 high error .....	54
330 Troubleshooting by failure code (Display of code), Part 3 .....	SEN04192-02
Failure code [CA428] Abnormally high level in water sensor .....	4
Failure code [CA429] Abnormally low level in water sensor .....	6
Failure code [CA431] Idle validation switch error .....	8
Failure code [CA432] Idle validation action error .....	12
Failure code [CA435] Engine oil pressure switch error .....	16
Failure code [CA441] Battery voltage low error .....	17
Failure code [CA442] Battery voltage high error .....	20
Failure code [CA449] Common rail pressure high error 2 .....	22
Failure code [CA451] Common rail pressure sensor high error .....	24
Failure code [CA452] Common rail pressure sensor low error .....	26
Failure code [CA488] Derating of torque by abnormally high charge temperature .....	28
Failure code [CA553] Common rail pressure high error 1 .....	29
Failure code [CA559] Supply pump pressure very low error .....	30
Failure code [CA689] Engine Ne speed sensor error .....	32
Failure code [CA731] Engine Bkup speed sensor phase error .....	34
Failure code [CA757] All continuous data lost error .....	35
Failure code [CA778] Engine Bkup speed sensor error .....	38
Failure code [CA1633] KOMNET datalink timeout error .....	40
Failure code [CA2185] Throttle sensor supply voltage high error .....	44
Failure code [CA2186] Throttle sensor power supply low error .....	46
Failure code [CA2249] Supply pump pressure very low error 2 .....	48
Failure code [CA2311] Abnormality in IMV (IMA) solenoid .....	50
Failure code [CA2555] Intake heater relay disconnection error .....	52
Failure code [CA2556] Intake heater relay short circuit error .....	54
340 Troubleshooting by failure code (Display of code), Part 4 .....	SEN04193-01
Failure code [D160KY] Backup alarm/lamp relay 1 circuit: Hot short .....	2
Failure code [D192KY] ECSS solenoid relay: Hot short .....	4
Failure code [D1B0KA] HST safety relay: Disconnection .....	6
Failure code [D1B0KB] HST safety relay: Ground fault .....	8
Failure code [D1B0KY] HST safety relay: Hot short .....	10
Failure code [D5ZHL6] IGN C system: Ground fault/Disconnection .....	12
Failure code [DAF3KK] UNSW power supply: Ground fault/Disconnection .....	14
Failure code [DAFRKR] Machine monitor CAN-NET Signal: Disconnection .....	16
Failure code [DAJ0KK] HST controller power supply: Low voltage .....	20
Failure code [DAJ0KT] HST controller memory (EEPROM): Abnormality .....	22
Failure code [DAJ1L4] HST controller main power line: Disconnection/Ground fault .....	24
Failure code [DAJ1L6] HST controller main power line: Hot short .....	26
Failure code [DAJ2KK] Controller solenoid power supply: Low voltage .....	28
Failure code [DAJ2L3] HST controller load power supply holding line: Hot short in wiring harness .....	30
Failure code [DAJ2L4] HST controller load power supply holding line: Disconnection/Ground fault .....	32
Failure code [DAJ5KX] Sensor 5V power supply: Out of output range .....	34
Failure code [DAJ9KQ] HST controller model selection: Disagreement of model selection signals .....	36
Failure code [DAJRKR] HST controller CAN-NET signal: Disconnection .....	37
Failure code [DAJRMA] HST controller: Disagreement in option selection .....	43
350 Troubleshooting by failure code (Display of code), Part 5 .....	SEN04194-01
Failure code [DB2RKR] Engine controller CAN-NET: Disconnection in signal line .....	2
Failure code [DD1NL4] Fan automatic reverse switch signal: Abnormality .....	8
Failure code [DD1NLD] Fan reverse switch signal: Abnormality .....	10
Failure code [DDB6KA] Parking brake reminder signal: Disconnection/Hot short .....	12
Failure code [DDB6KB] Parking brake indicator signal: Ground fault .....	14
Failure code [DDB6KZ] Parking brake switch (bottom switch) or parking brake reminder switch (intermediate switch): Trouble .....	16
Failure code [DDB6L0] Parking brake reminder signal: Ground fault .....	18

Failure code [DDB6L4] Parking brake indicator signal: Disconnection/Hot short.....	20
Failure code [DDD7KX] Travel speed control dial signal: Disconnection/Ground fault .....	22
Failure code [DDD7KY] Travel speed control dial signal: Hot short .....	24
Failure code [DDE5MA] Emergency steering operation switch: Disconnection .....	26
Failure code [DDK6KA] FNR lever: Disconnection/Ground fault.....	28
Failure code [DDK6KY] FNR lever: Hot short.....	32
Failure code [DDS5L6] Steering: Low oil pressure (Operation of emergency steering) .....	34
<b>360 Troubleshooting by failure code (Display of code), Part 6</b> .....	<b>SEN04195-01</b>
Failure code [DF10KA] Travel speed range selector switch: Disconnection/Ground fault .....	2
Failure code [DF10KB] Travel speed range selector switch: Hot short .....	6
Failure code [DGH1KX] HST oil temperature sensor: Ground fault .....	8
Failure code [DGR2KB] Brake oil temperature sensor: Ground fault.....	9
Failure code [DGR2KZ] Brake oil temperature sensor: Disconnection/Hot short.....	10
Failure code [DHH1KX] HST oil pressure sensor: Disconnection/Ground fault .....	12
Failure code [DHH1KY] HST oil pressure sensor: Hot short .....	14
Failure code [DHTCL6] HST filter clogging sensor: Functional defect .....	16
Failure code [DJF1KA] Fuel level sensor: Disconnection/Hot short .....	18
Failure code [DLT3KX] Travel speed sensor B: Abnormality.....	20
Failure code [DLT4KX] Travel speed sensor A: Abnormality.....	24
Failure code [DLT4LC] Travel speed sensor A & B: Abnormality .....	26
Failure code [DV00KY] Alarm buzzer: Hot short .....	28
Failure code [DW26KA] Motor 2 solenoid: Disconnection/Ground fault .....	30
Failure code [DW26KY] Motor 2 solenoid: Hot short.....	32
Failure code [DW7BKY] Fan reverse solenoid circuit: Hot short .....	34
Failure code [DW7BKZ] Fan reverse solenoid circuit: Disconnection/Ground fault .....	36
<b>370 Troubleshooting by failure code (Display of code), Part 7</b> .....	<b>SEN04196-00</b>
Failure code [DX16KA] Fan EPC solenoid: Disconnection .....	2
Failure code [DX16KB] Fan EPC solenoid: Ground fault .....	3
Failure code [DX16KY] Fan EPC solenoid: Hot short .....	4
Failure code [DX19KA] Motor 1 solenoid: Disconnection.....	6
Failure code [DX19KB] Motor 1 solenoid: Ground fault.....	8
Failure code [DX19KY] Motor 1 solenoid: Hot short.....	10
Failure code [DX20KA] Clutch EPC solenoid: Disconnection .....	12
Failure code [DX20KB] Clutch EPC solenoid: Ground fault .....	14
Failure code [DX20KY] Clutch EPC solenoid: Hot short .....	16
Failure code [DXH7KB] Reverse solenoid: Ground fault.....	18
Failure code [DXH7KZ] Reverse solenoid: Disconnection/Hot short.....	20
Failure code [DXH8KB] Forward solenoid: Ground fault.....	22
Failure code [DXH8KZ] Forward solenoid: Disconnection/Hot short.....	24
Failure code [J141N1] Steering pump: Overrun alarm .....	26
Failure code [M100N1] HST pump: Overrun alarm .....	26
Failure code [M400N1] Motor 1: Overrun alarm .....	27
<b>400 Troubleshooting of electrical system (E-mode)</b> .....	<b>SEN04197-01</b>
E-1 Engine does not start .....	3
E-2 Preheater does not operate normally.....	10
E-3 Travel speed is low or high .....	14
E-4 ECSS does not operate .....	20
E-5 ECSS keeps operating.....	23
E-6 Defective boom kick-out function and cancellation .....	26
E-7 Defective bucket positioner function and cancellation .....	30
E-8 Defective lift arm FLOATING holding function and cancellation .....	34
E-9 Travel direction selection system does not function.....	38
E-10 Fan does not reverse .....	42
E-11 Fan keeps rotating in reverse.....	46
E-12 Wiper does not operate.....	48
E-13 Windshield washer does not operate.....	52
E-14 Headlamp, clearance lamp and tail lamp do not light up or go off .....	56
E-15 Working lamp does not light up or go off.....	64

E-16 Turn signal lamp and hazard lamp do not light up or go off.....	70
E-17 Brake lamp does not light or it keeps lighting up .....	76
E-18 Backup lamp does not light or it keeps lighting up .....	78
E-19 Backup alarm does not sound or it keeps sounding.....	81
E-20 Horn does not sound or it keeps sounding .....	84
E-21 Alarm buzzer does not sound or it keeps sounding.....	86
E-22 Air conditioner does not operate or stop.....	88
E-23 The KOMTRAX system does not work properly .....	92
500 Troubleshooting of hydraulic and mechanical system (H-mode)	SEN04198-01
Method of using troubleshooting chart .....	3
Failure code and cause table .....	6
H-1 The machine does not start.....	8
H-2 The travel speed is slow .....	9
H-3 The traction force is weak .....	10
H-4 Engine stalls when traveling or engine speed drops excessively.....	11
H-5 Shift range is not shifted .....	12
H-6 The steering wheel does not turn .....	13
H-7 The steering wheel is heavy.....	14
H-8 Steering wheel shakes or jerks.....	15
H-9 Machine deviates naturally to one side when traveling .....	15
H-10 The brake does not work or does not work well .....	16
H-11 The brake is not released or is dragged .....	17
H-12 The lift arm does not rise or lower .....	18
H-13 The lift arm moves slowly or the lift arm rising force is insufficient .....	19
H-14 When rising, the lift arm comes to move slowly at specific height.....	20
H-15 The lift arm cylinder cannot hold down the bucket (The bucket rises in the air).....	20
H-16 Hydraulic drifts of the lift arm occur often .....	20
H-17 The lift arm wobbles during operation .....	20
H-18 When the control lever is switched from "HOLD" to "RAISE," the lift arm falls temporarily .....	21
H-19 The bucket does not tilt back.....	22
H-20 The bucket moves slowly or the tilting-back force is insufficient .....	23
H-21 The bucket comes to operate slowly in the midst of tilting-back .....	24
H-22 The bucket cylinder cannot hold down the bucket .....	24
H-23 Hydraulic drifts of the bucket occur often .....	24
H-24 The bucket wobbles during travel with load (The work equipment valve is set to "HOLD") .....	24
H-25 When the control lever is switched from "HOLD" to "TILT," the bucket falls temporarily .....	25
H-26 The control levers of the lift arm and bucket do not move smoothly and heavy.....	25
H-27 The ECSS does not operate and machine pitches and bounces.....	26
H-28 Fan revolution is abnormal (Fan sound/vibration is abnormally large or engine overheats) .....	27
600 Troubleshooting of engine (S-mode)	SEN04199-01
Method of using troubleshooting charts .....	2
S-1 Starting performance is poor .....	6
S-2 Engine does not start.....	8
S-3 Engine does not pick up smoothly.....	11
S-4 Engine stops during operations .....	12
S-5 Engine does not rotate smoothly .....	13
S-6 Engine lacks output (or lacks power).....	14
S-7 Exhaust smoke is black (incomplete combustion).....	15
S-8 Oil consumption is excessive (or exhaust smoke is blue) .....	16
S-9 Oil becomes contaminated quickly .....	17
S-10 Fuel consumption is excessive .....	18
S-11 Oil is in coolant (or coolant spurts back or coolant level goes down) .....	19
S-12 Oil pressure drops .....	20
S-13 Oil level rises (Entry of coolant or fuel).....	21
S-14 Coolant temperature becomes too high (overheating) .....	22
S-15 Abnormal noise is made .....	23
S-16 Vibration is excessive .....	24



50 Disassembly and assembly	
100 General information on disassembly and assembly	SEN04200-02
Coating materials list .....	4
Coating materials list .....	4
Special tool list .....	7
Sketches of special tools .....	11
200 Engine and cooling system	SEN04201-03
Removal and installation of fuel supply pump assembly .....	2
Removal and installation of fuel injector assembly .....	5
Removal and installation of cylinder head assembly .....	13
Removal and installation of engine hood assembly .....	25
Removal and installation of radiator .....	28
Removal and installation of air aftercooler .....	31
Removal and installation of hydraulic oil cooler assembly .....	33
Removal and installation of engine assembly .....	35
Removal and installation of engine front oil seal assembly .....	41
Removal and installation of engine rear oil seal assembly .....	44
Removal and installation of cooling fan and fan motor assembly .....	47
Removal and installation of fuel tank assembly .....	50
310 Power train, Part 1	SEN04202-00
Removal and installation of transfer assembly .....	2
Disassembly and assembly of transfer assembly .....	5
Removal and installation of parking brake assembly .....	24
Disassembly and assembly of parking brake assembly .....	25
320 Power train, Part 2	SEN04203-00
Removal and installation of front axle assembly .....	2
Removal and installation of rear axle assembly .....	4
Disassembly and assembly of axle housing assembly .....	7
Disassembly and assembly of differential assembly .....	19
400 Undercarriage and frame	SEN04204-00
Removal and installation of center hinge pin .....	2
Removal and installation of counterweight assembly .....	12
500 Hydraulic system	SEN04205-00
Removal and installation of HST pump and 4-gear pump assembly .....	2
Disassembly and assembly of HST pump assembly .....	5
Removal and installation of HST motor 1 assembly .....	32
Removal and installation of HST motor 2 assembly .....	34
Disassembly and assembly of HST motor assembly .....	36
Removal and installation of work equipment control valve assembly .....	52
Removal and installation of hydraulic tank assembly .....	54
Disassembly and assembly of hydraulic cylinder assembly .....	56
600 Work equipment	SEN04206-00
Removal and installation of work equipment assembly .....	2
700 Cab and its attachments	SEN04207-01
Removal and installation of operator's cab and floor frame assembly .....	2
Removal and installation of operator's cab glass (Stuck glass) .....	8
Disassembly and assembly of operator's seat assembly .....	16
Removal and installation of air conditioner unit .....	26
800 Electrical system	SEN04208-00
Removal and installation of monitor panel .....	2
Removal and installation of engine controller assembly .....	4
Removal and installation of HST controller assembly .....	5
Removal and installation of KOMTRAX terminal assembly .....	6

90 Diagrams and drawings	
100 Hydraulic diagrams and drawings	SEN04209-01
Automatic greasing circuit diagram .....	2
Hydraulic circuit diagram .....	5
200 Electrical diagrams and drawings	SEN04210-03
Electrical circuit diagram .....	3
Connector list and stereogram .....	29

# WHEEL LOADER

## WA320-6

## WA320PZ-6

**Machine model      Serial number**

**WA320-6              70001 and up**

**WA320PZ-6         70001 and up**

---

## 00 Index and foreword

### 200 Foreword and general information

---

---

Safety notice .....	2
How to read the shop manual .....	7
Explanation of terms for maintenance standard .....	9
Handling of electric equipment and hydraulic component .....	11
Handling of connectors newly used for engines .....	20
How to read electric wire code .....	23
Precautions when carrying out operation .....	26
Method of disassembling and connecting push-pull type coupler .....	29
Standard tightening torque table .....	32
Conversion table .....	36

## Safety notice

(Rev. 2008/08)

### Important safety notice

Proper service and repair are extremely important for safe machine operation. The service and repair techniques recommended by Komatsu and described in this manual are both effective and safe. Some of these techniques require the use of tools specially designed by Komatsu for the specific purpose.

To prevent injury to workers, the symbol **▲** is used to mark safety precautions in this manual. The cautions accompanying these symbols should always be followed carefully. If any dangerous situation arises or may possibly arise, first consider safety, and take the necessary actions to deal with the situation.

### 1. General precautions

**▲ Mistakes in operation are extremely dangerous. Read the Operation and Maintenance Manual carefully before operating the machine. In addition, read this manual and understand its contents before starting the work.**

- 1) Before carrying out any greasing or repairs, read all the safety labels stuck to the machine. For the locations of the safety labels and detailed explanation of precautions, see the Operation and Maintenance Manual.
- 2) Decide a place in the repair workshop to keep tools and removed parts. Always keep the tools and parts in their correct places. Always keep the work area clean and make sure that there is no dirt, water, or oil on the floor. Smoke only in the areas provided for smoking. Never smoke while working.
- 3) When carrying out any operation, always wear safety shoes and helmet. Do not wear loose work clothes, or clothes with buttons missing.
  - Always wear safety glasses when hitting parts with a hammer.
  - Always wear safety glasses when grinding parts with a grinder, etc.
- 4) When carrying out any operation with 2 or more workers, always agree on the operating procedure before starting. Always inform your fellow workers before starting any step of the operation. Before starting work, hang UNDER REPAIR warning signs in the operator's compartment.
- 5) Only qualified workers must carry out work and operation which require license or qualification.
- 6) Keep all tools in good condition, learn the correct way to use them, and use the proper ones of them. Before starting work, thoroughly check the tools, machine, forklift, service car, etc.

- 7) If welding repairs are needed, always have a trained and experienced welder carry out the work. When carrying out welding work, always wear welding gloves, apron, shielding goggles, cap and other clothes suited for welding work.
- 8) Before starting work, warm up your body thoroughly to start work under good condition.
- 9) Avoid continuing work for long hours and take rests at proper intervals to keep your body in good condition. Take rests in specified safe places.

### Safety points

1	Good arrangement
2	Correct work clothes
3	Following work standard
4	Making and checking signs
5	Prohibition of operation and handling by unlicensed workers
6	Safety check before starting work
7	Wearing protective goggles (for cleaning or grinding work)
8	Wearing shielding goggles and protectors (for welding work)
9	Good physical condition and preparation
10	Precautions against work which you are not used to or you are used to too much

## 2. Preparations for work

- 1) Before adding oil or making any repairs, park the machine on a hard and level ground, and apply the parking brake and block the wheels or tracks to prevent the machine from moving.
- 2) Before starting work, lower the work equipment (blade, ripper, bucket, etc.) to the ground. If this is not possible, insert the lock pin or use blocks to prevent the work equipment from falling. In addition, be sure to lock all the control levers and hang warning signs on them.
- 3) When disassembling or assembling, support the machine with blocks, jacks, or stands before starting work.
- 4) Remove all mud and oil from the steps or other places used to get on and off the machine. Always use the handrails, ladders or steps when getting on or off the machine. Never jump on or off the machine. If it is impossible to use the handrails, ladders or steps, use a stand to provide safe footing.

## 3. Precautions during work

- 1) Before disconnecting or removing components of the oil, water, or air circuits, first release the pressure completely from the circuit. When removing the oil filler cap, a drain plug, or an oil pressure pickup plug, loosen it slowly to prevent the oil from spurting out.
- 2) The coolant and oil in the circuits are hot when the engine is stopped, so be careful not to get scalded. Wait for the oil and coolant to cool before carrying out any work on the oil or water circuits.
- 3) Before starting work, stop the engine. When working on or around a rotating part, in particular, stop the engine. When checking the machine without stopping the engine (measuring oil pressure, revolving speed, temperature, etc.), take extreme care not to get rolled or caught in rotating parts or moving parts.
- 4) Before starting work, remove the leads from the battery. Always remove the lead from the negative (-) terminal first.
- 5) When raising a heavy component (heavier than 25 kg), use a hoist or crane. Before starting work, check that the slings (wire ropes, chains, and hooks) are free from damage. Always use slings which have ample capacity and install them to proper places. Operate the hoist or crane slowly to prevent the component from hitting any other part. Do not work with any part still raised by the hoist or crane.
- 6) When removing a cover which is under internal pressure or under pressure from a spring, always leave 2 bolts in diagonal positions. Loosen those bolts gradually and alternately to release the pressure, and then remove the cover.
- 7) When removing components, be careful not to break or damage the electrical wiring. Damaged wiring may cause electrical fires.
- 8) When removing piping, stop the fuel or oil from spilling out. If any fuel or oil drips onto the floor, wipe it up immediately. Fuel or oil on the floor can cause you to slip and can even start fires.
- 9) As a general rule, do not use gasoline to wash parts. Do not use it to clean electrical parts, in particular.
- 10) Be sure to assemble all parts again in their original places. Replace any damaged parts and parts which must not be reused with new parts. When installing hoses and wires, be sure that they will not be damaged by contact with other parts when the machine is operated.
- 11) When installing high pressure hoses, make sure that they are not twisted. Damaged tubes are dangerous, so be extremely careful when installing tubes for high pressure circuits. In addition, check that connecting parts are correctly installed.
- 12) When assembling or installing parts, always tighten them to the specified torques. When installing protective parts such as guards, or parts which vibrate violently or rotate at high speed, be particularly careful to check that they are installed correctly.
- 13) When aligning 2 holes, never insert your fingers or hand. Be careful not to get your fingers caught in a hole.
- 14) When measuring hydraulic pressure, check that the measuring tools are correctly assembled.
- 15) Take care when removing or installing the tracks of track-type machines. When removing the track, the track separates suddenly, so never let anyone stand at either end of the track.
- 16) If the engine is operated for a long time in a place which is not ventilated well, you may suffer from gas poisoning. Accordingly, open the windows and doors to ventilate well.

**4. Precautions for sling work and making signs**

- 1) Only one appointed worker must make signs and co-workers must communicate with each other frequently. The appointed sign maker must make specified signs clearly at a place where he is well seen from the operator's seat and where he can see the working condition easily. The sign maker must always stand in front of the load and guide the operator safely.
  - Do not stand under the load.
  - Do not step on the load.
- 2) Check the slings before starting sling work.
- 3) Keep putting on gloves during sling work. (Put on leather gloves, if available.)
- 4) Measure the weight of the load by the eye and check its center of gravity.
- 5) Use proper sling according to the weight of the load and method of slinging. If too thick wire ropes are used to sling a light load, the load may slip and fall.
- 6) Do not sling a load with 1 wire rope alone. If it is slung so, it may rotate and may slip out of the rope. Install 2 or more wire ropes symmetrically.

**⚠ Slinging with 1 rope may cause turning of the load during hoisting, untwisting of the rope, or slipping of the rope from its original winding position on the load, which can result in a dangerous accident.**

- 7) Limit the hanging angle to 60°, as a rule. Do not sling a heavy load with ropes forming a wide hanging angle from the hook. When hoisting a load with 2 or more ropes, the force subjected to each rope will increase with the hanging angle. The table below shows the variation of allowable load in kN {kg} when hoisting is made with 2 ropes, each of which is allowed to sling up to 9.8 kN {1,000 kg} vertically, at various hanging angles. When the 2 ropes sling a load vertically, up to 19.6 kN {2,000 kg} of total weight can be suspended. This weight is reduced to 9.8 kN {1,000 kg} when the 2 ropes make a hanging angle of 120°. If the 2 ropes sling a 19.6 kN {2,000 kg} load at a lifting angle of 150°, each of them is subjected to a force as large as 39.2 kN {4,000 kg}.

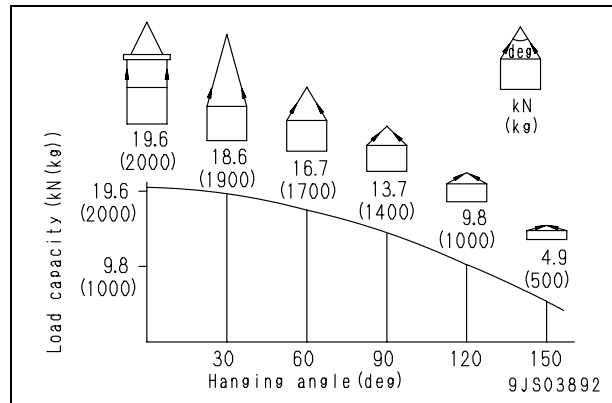

- 8) When installing wire ropes to an angular load, apply pads to protect the wire ropes. If the load is slippery, apply proper material to prevent the wire rope from slipping.
- 9) Use the specified eyebolts and fix wire ropes, chains, etc. to them with shackles, etc.
- 10) Apply wire ropes to the middle portion of the hook.
  - Slinging near the tip of the hook may cause the rope to slip off the hook during hoisting. The hook has the maximum strength at the middle portion.

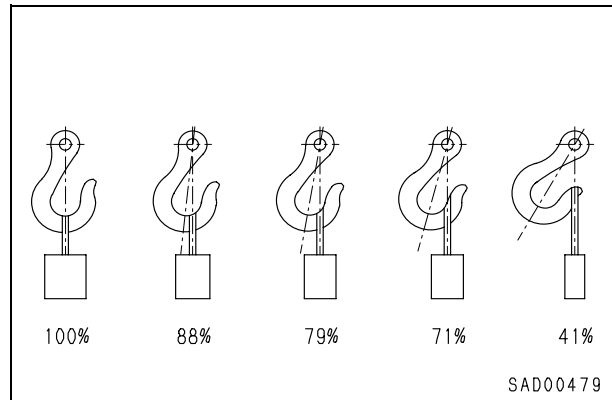

- 11) Do not use twisted or kinked wire ropes.
- 12) When lifting up a load, observe the following.
  - Wind in the crane slowly until wire ropes are stretched. When settling the wire ropes with the hand, do not grasp them but press them from above. If you grasp them, your fingers may be caught.
  - After the wire ropes are stretched, stop the crane and check the condition of the slung load, wire ropes, and pads.

- If the load is unstable or the wire rope or chains are twisted, lower the load and lift it up again.
  - Do not lift up the load slantingly.
- 13) When lifting down a load, observe the following.
- When lifting down a load, stop it temporarily at 30 cm above the floor, and then lower it slowly.
  - Check that the load is stable, and then remove the sling.
  - Remove kinks and dirt from the wire ropes and chains used for the sling work, and put them in the specified place.

#### 5. Precautions for using mobile crane

- ★ Read the Operation and Maintenance Manual of the crane carefully in advance and operate the crane safely.

#### 6. Precautions for using overhead hoist crane

**▲ When raising a heavy part (heavier than 25 kg), use a hoist, etc. In Disassembly and assembly, the weight of a part heavier than 25 kg is indicated after the mark of .**

- 1) Before starting work, inspect the wire ropes, brake, clutch, controller, rails, over wind stop device, electric shock prevention earth leakage breaker, crane collision prevention device, and power application warning lamp, and check safety.
- 2) Observe the signs for sling work.
- 3) Operate the hoist at a safe place.
- 4) Check the direction indicator plates (east, west, south, and north) and the directions of the control buttons without fail.
- 5) Do not sling a load slantingly. Do not move the crane while the slung load is swinging.
- 6) Do not raise or lower a load while the crane is moving longitudinally or laterally.
- 7) Do not drag a sling.
- 8) When lifting up a load, stop it just after it leaves the ground and check safety, and then lift it up.
- 9) Consider the travel route in advance and lift up a load to a safe height.
- 10) Place the control switch on a position where it will not be an obstacle to work and passage.
- 11) After operating the hoist, do not swing the control switch.
- 12) Remember the position of the main switch so that you can turn off the power immediately in an emergency.

- 13) If the hoist stops because of a power failure, turn the power switch OFF. When turning on a switch which was turned OFF by the electric shock prevention earth leakage breaker, check that the devices related to that switch are not in operation state.
- 14) If you find an obstacle around the hoist, stop the operation.
- 15) After finishing the work, stop the hoist at the specified position and raise the hook to at least 2 m above the floor. Do not leave the sling installed to the hook.

#### 7. Selecting wire ropes

- 1) Select adequate ropes depending on the weight of parts to be hoisted, referring to the table below.

Wire ropes  
(Standard "Z" twist ropes without galvanizing)  
(JIS G3525, No. 6, Type 6X37-A)

Nominal diameter of rope mm	Allowable load	
	kN	ton
10	8.8	0.9
12	12.7	1.3
14	17.3	1.7
16	22.6	2.3
18	28.6	2.9
20	35.3	3.6
25	55.3	5.6
30	79.6	8.1
40	141.6	14.4
50	221.6	22.6
60	318.3	32.4

- ★ The allowable load is one-sixth of the breaking strength of the rope used (Safety coefficient: 6).

## 8. Precautions for disconnecting and connecting hoses and tubes in air conditioner circuit

### 1) Disconnection

**⚠ For the environment, the air conditioner of this machine uses the refrigerant (air conditioner gas: R134a) which has fewer factors of the depletion of the ozone layer. However, it does not mean that you may discharge the refrigerant into the atmosphere as it is. Be sure to recover the refrigerant when disconnecting the refrigerant gas circuit and then reuse it.**

★ Ask professional traders for collecting and filling operation of refrigerant (R134a).

★ Never release the refrigerant (R134a) to the atmosphere.

**⚠ If the refrigerant gas gets in your eyes or contacts your skin, you may lose your sight and your skin may be frozen. Accordingly, put on safety glasses, safety gloves and safety clothes when recovering or adding the refrigerant. Refrigerant gas must be recovered and added by a qualified person.**

### 2) Connection

1] When installing the air conditioner circuit hoses and tubes, take care that dirt, dust, water, etc. will not enter them.

2] When connecting the air conditioner hoses and tubes, check that O-rings (1) are fitted to their joints.

3] Check that each O-ring is not damaged or deteriorated.

4] When connecting the refrigerant piping, apply compressor oil for refrigerant (R134a) (**DENSO: ND-OIL8, VALEO THERMAL SYSTEMS: ZXL100PG (equivalent to PAG46)**) to its O-rings.

★ Example of O-ring (Fitted to every joint of hoses and tubes)

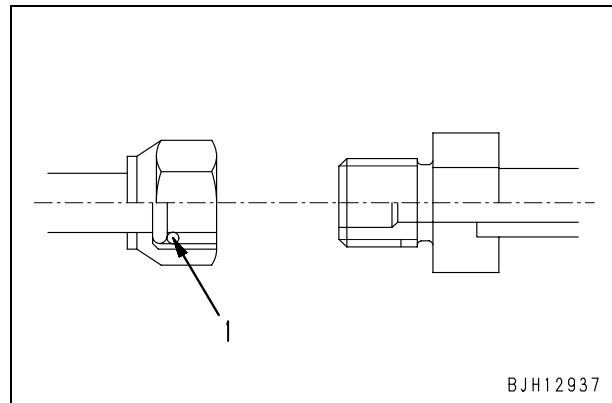

★ For tightening torque, see the precautions for installation in each section of "Disassembly and assembly".



## How to read the shop manual

- Some attachments and optional parts in this shop manual may not be delivered to certain areas. If one of them is required, consult KOMATSU distributors.
- Materials and specifications are subject to change without notice.
- Shop manuals are divided into the “Chassis volume” and “Engine volume”. For the engine unit, see the engine volume of the engine model mounted on the machine.

### 1. Composition of shop manual

This shop manual contains the necessary technical information for services performed in a workshop. For ease of understanding, the manual is divided into the following sections.

#### 00. Index and foreword

This section explains the shop manuals list, table of contents, safety, and basic information.

#### 01. Specification

This section explains the specifications of the machine.

#### 10. Structure, function and maintenance standard

This section explains the structure, function, and maintenance standard values of each component. The structure and function sub-section explains the structure and function of each component. It serves not only to give an understanding of the structure, but also serves as reference material for troubleshooting. The maintenance standard sub-section explains the criteria and remedies for disassembly and service.

#### 20. Standard value table

This section explains the standard values for new machine and judgement criteria for testing, adjusting, and troubleshooting. This standard value table is used to check the standard values in testing and adjusting and to judge parts in troubleshooting.

#### 30. Testing and adjusting

This section explains measuring instruments and measuring methods for testing and adjusting, and method of adjusting each part. The standard values and judgement criteria for testing and adjusting are explained in Testing and adjusting.

#### 40. Troubleshooting

This section explains how to find out failed parts and how to repair them. The troubleshooting is divided by failure modes. The “S mode” of the troubleshooting related to the engine may be also explained in the Chassis volume and Engine volume. In this case, see the Chassis volume.

#### 50. Disassembly and assembly

This section explains the special tools and procedures for removing, installing, disassembling, and assembling each component, as well as precautions for them. In addition, tightening torque and quantity and weight of coating material, oil, grease, and coolant necessary for the work are also explained.

#### 90. Diagrams and drawings (chassis volume)/Repair and replacement of parts (engine volume)

- Chassis volume  
This section gives hydraulic circuit diagrams and electrical circuit diagrams.
- Engine volume  
This section explains the method of reproducing, repairing, and replacing parts.

### 2. Revision and distribution

Any additions, revisions, or other change of notices will be sent to KOMATSU distributors. Get the most up-to-date information before you start any work.

**3. Filing method**

File by the brochures in the correct order of the form number printed in the shop manual composition table.

- **Revised edition mark**







When a manual is revised, the ones and tens digits of the form number of each brochure is increased by 1. (Example: 00, 01, 02 ...)

- **Revisions**

Revised brochures are shown in the shop manual composition table.

**4. Symbols**

Important safety and quality portions are marked with the following symbols so that the shop manual will be used practically.

Symbol	Item	Remarks
	Safety	Special safety precautions are necessary when performing work.
	Caution	Special technical precautions or other precautions for preserving standards are necessary when performing work.
	Weight	Weight of parts of component or parts. Caution necessary when selecting hoisting wire, or when working posture is important, etc.
	Tightening torque	Places that require special attention for tightening torque during assembly.
	Coat	Places to be coated with adhesives, etc. during assembly.
	Oil, coolant	Places where oil, etc. must be added, and capacity.
	Drain	Places where oil, etc. must be drained, and quantity to be drained.

**5. Units**

In this shop manual, the units are indicated with International System of units (SI). For reference, conventionally used Gravitational System of units is indicated in parentheses { }.

## Explanation of terms for maintenance standard

The maintenance standard chapter explains the criteria for replacing or reusing products and parts in the machine maintenance work. The following terms are used to explain the criteria.

### 1. Standard size and tolerance

- To be accurate, the finishing size of parts is a little different from one to another.
- To specify a finishing size of a part, a temporary standard size is set and an allowable difference from that size is indicated.
- The above size set temporarily is called the “standard size” and the range of difference from the standard size is called the “tolerance”.
- The tolerance with the symbols of + or – is indicated on the right side of the standard size.

Example:

Standard size	Tolerance
120	-0.022 -0.126

- ★ The tolerance may be indicated in the text and a table as [standard size (upper limit of tolerance/lower limit of tolerance)].  
Example) 120 (-0.022/-0.126)
- Usually, the size of a hole and the size of the shaft to be fitted to that hole are indicated by the same standard size and different tolerances of the hole and shaft. The tightness of fit is decided by the tolerance.
- Indication of size of rotating shaft and hole and relationship drawing of them

Example:

Standard size	Tolerance	
	Shaft	Hole
60	-0.030 -0.076	+0.046 0

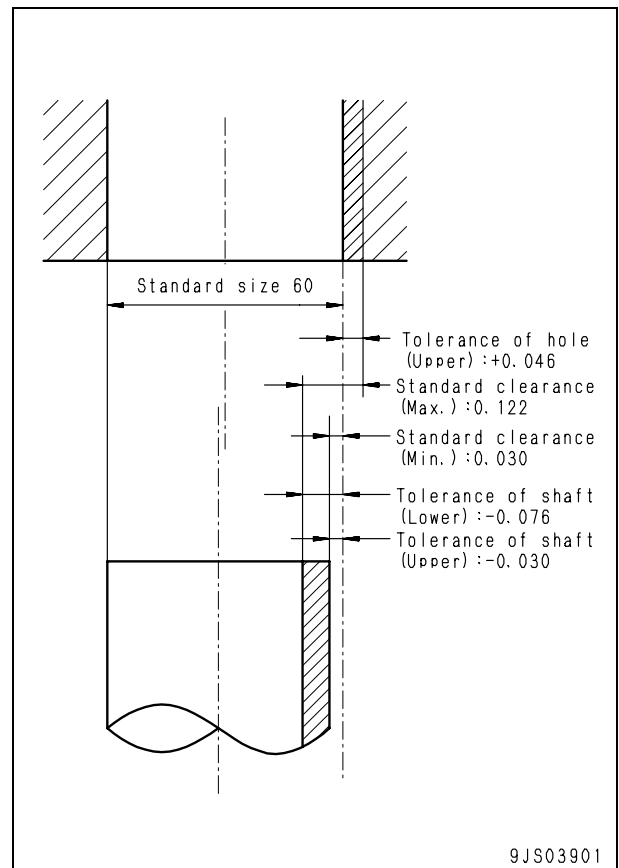

**2. Standard clearance and standard value**

- The clearance made when new parts are assembled is called the “standard clearance”, which is indicated by the range from the minimum clearance to the maximum clearance.
- When some parts are repaired, the clearance is generally adjusted to the standard clearance.
- A value of performance and function of new products or equivalent is called the “standard value”, which is indicated by a range or a target value.
- When some parts are repaired, the value of performance/function is set to the standard value.

**3. Standard interference**

- When the diameter of a hole of a part shown in the given standard size and tolerance table is smaller than that of the mating shaft, the difference between those diameters is called the “interference”.
- The range (A – B) from the difference (A) between the minimum size of the shaft and the maximum size of the hole to the difference (B) between the maximum size of the shaft and the minimum size of the hole is the “standard interference”.
- After repairing or replacing some parts, measure the size of their hole and shaft and check that the interference is in the standard range.

**4. Repair limit and allowable value or allowable dimension**

- The size of a part changes because of wear and deformation while it is used. The limit of changed size is called the “repair limit”.
- If a part is worn to the repair limit, it must be replaced or repaired.
- The performance and function of a product lowers while it is used. A value which the product can be used without causing a problem is called the “allowable value” or “allowable dimension”.
- If a product is worn to the allowable value, it must be checked or repaired. Since the permissible value is estimated from various tests or experiences in most cases, however, it must be judged after considering the operating condition and customer's requirement.

**5. Clearance limit**

- Parts can be used until the clearance between them is increased to a certain limit. The limit at which those parts cannot be used is called the “clearance limit”.
- If the clearance between the parts exceeds the clearance limit, they must be replaced or repaired.

**6. Interference limit**

- The allowable maximum interference between the hole of a part and the shaft of another part to be assembled is called the “interference limit”.
- The interference limit shows the repair limit of the part of smaller tolerance.
- If the interference between the parts exceeds the interference limit, they must be replaced or repaired.

## Handling of electric equipment and hydraulic component

To maintain the performance of the machine over a long period, and to prevent failures or other troubles before they occur, correct “operation”, “maintenance and inspection”, “troubleshooting”, and “repairs” must be carried out. This section deals particularly with correct repair procedures for mechatronics and is aimed at improving the quality of repairs. For this purpose, it gives sections on “Handling electric equipment” and “Handling hydraulic equipment” (particularly gear oil and hydraulic oil).

### Points to remember when handling electric equipment

#### 1. Handling wiring harnesses and connectors

Wiring harnesses consist of wiring connecting one component to another component, connectors used for connecting and disconnecting one wire from another wire, and protectors or tubes used for protecting the wiring.

Compared with other electrical components fitted in boxes or cases, wiring harnesses are more likely to be affected by the direct effects of rain, water, heat, or vibration. Furthermore, during inspection and repair operations, they are frequently removed and installed again, so they are likely to suffer deformation or damage. For this reason, it is necessary to be extremely careful when handling wiring harnesses.

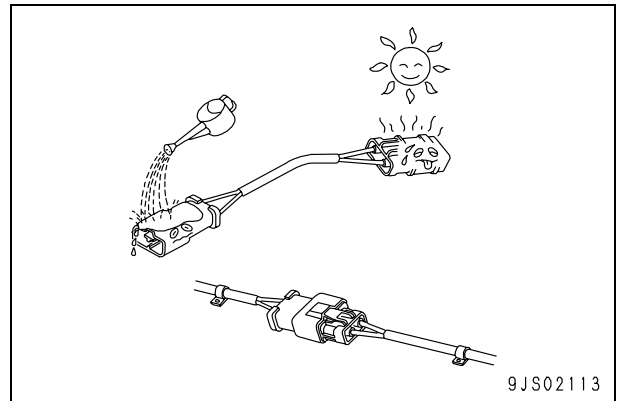

#### 2. Main failures occurring in wiring harness

##### 1) Defective contact of connectors (defective contact between male and female)

Problems with defective contact are likely to occur because the male connector is not properly inserted into the female connector, or because one or both of the connectors is deformed or the position is not correctly aligned, or because there is corrosion or oxidization of the contact surfaces. The corroded or oxidized contact surfaces may become shiny again (and contact may become normal) by connecting and disconnecting the connector about 10 times.

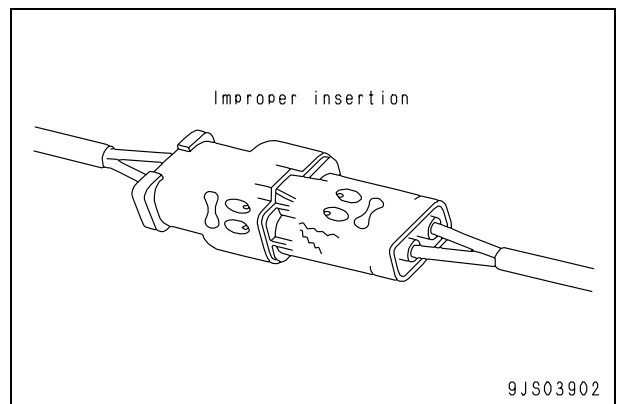

##### 2) Defective crimping or soldering of connectors

The pins of the male and female connectors are in contact at the crimped terminal or soldered portion, but if there is excessive force brought to bear on the wiring, the plating at the joint will peel and cause improper connection or breakage.

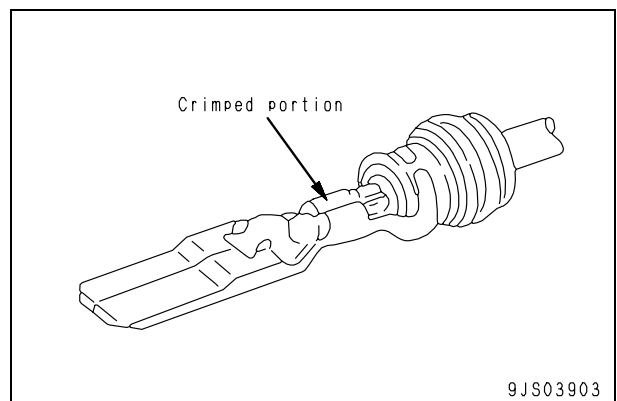

- 3) Disconnections in wiring  
 If the wiring is held and the connectors are pulled apart, or components are lifted with a crane with the wiring still connected, or a heavy object hits the wiring, the crimping of the connector may separate, or the soldering may be damaged, or the wiring may be broken.

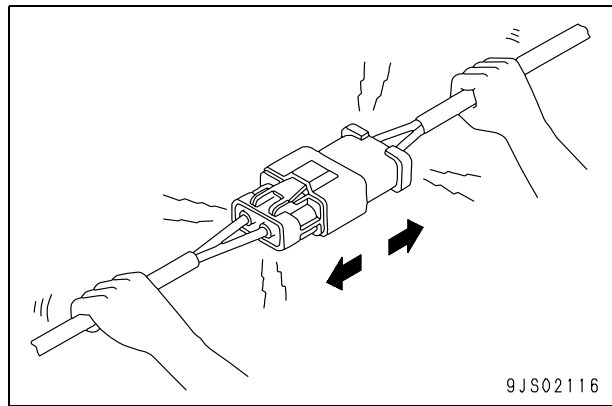

- 4) High-pressure water entering connector  
 The connector is designed to make it difficult for water to enter (drip-proof structure), but if high-pressure water is sprayed directly on the connector, water may enter the connector, depending on the direction of the water jet. Accordingly, take care not to splash water over the connector. The connector is designed to prevent water from entering, but at the same time, if water does enter, it is difficult for it to be drained. Therefore, if water should get into the connector, the pins will be short-circuited by the water, so if any water gets in, immediately dry the connector or take other appropriate action before passing electricity through it.

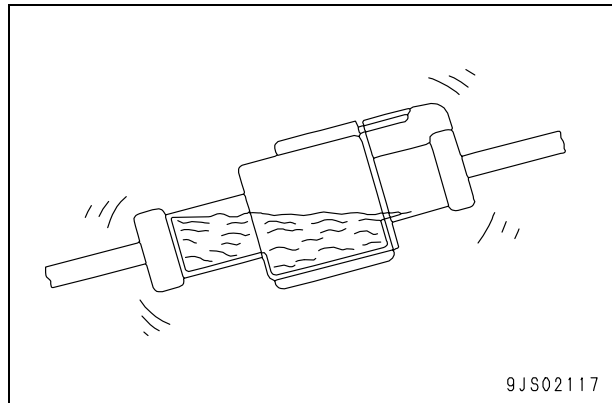

- 5) Oil or dirt stuck to connector  
 If oil or grease are stuck to the connector and an oil film is formed on the mating surface between the male and female pins, the oil will not let the electricity pass, so there will be defective contact. If there is oil or grease stuck to the connector, wipe it off with a dry cloth or blow it dry with compressed air and spray it with a contact restorer.

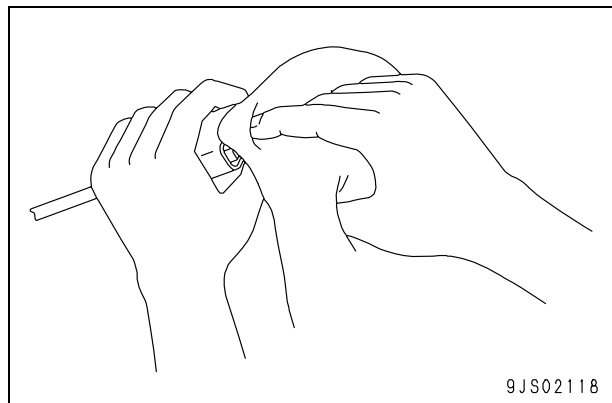

- ★ When wiping the mating portion of the connector, be careful not to use excessive force or deform the pins.
- ★ If there is oil or water in the compressed air, the contacts will become even dirtier, so remove the oil and water from the compressed air completely before cleaning with compressed air.



**Download the full PDF manual instantly.**

**Our customer service e-mail:**

**[aservicemanualpdf@yahoo.com](mailto:aservicemanualpdf@yahoo.com)**