

PREFACE

This manual covers the construction, function and servicing procedures of the Honda BF8D, BF9.9D, BF10D, BF8B, BF10B, BFP8D, BFP9.9D, BFP10D, BFP8B and BFP10B outboard motors. (BFP8D, BFP9.9D, BFP10D, BFP8B and BFP10B: Power thrust type)

Careful observance of these instructions will result in better, safer service work.

Pay attention to these symbols and their meaning:

▲ WARNING Indicates a strong possibility of severe personal injury or loss of life if instructions are not followed.

CAUTION: Indicates a possibility of personal injury or equipment damage if instructions are not followed.

ALL INFORMATIONS, ILLUSTRATIONS, DIRECTIONS AND SPECIFICATIONS INCLUDED IN THIS PUBLICATION ARE BASED ON THE LATEST PRODUCT INFORMATION AVAILABLE AT THE TIME OF APPROVAL FOR PRINTING. Honda Motor Co., Ltd. RESERVES THE RIGHT TO MAKE CHANGES WITHOUT INCURRING ANY OBLIGATION WHATEVER. NO PART OF THIS PUBLICATION MAY BE REPRODUCED WITHOUT WRITTEN PERMISSION.

Honda Motor Co., Ltd.
Service Publications Office

CONTENTS

SPECIFICATIONS	1
SERVICE INFORMATION	2
MAINTENANCE	3
PROPELLER/GEAR CASE/EXTENSION CASE	4
ENGINE COVERS	5
FUEL SYSTEM	6
RECOIL STARTER	7
ENGINE REMOVAL/INSTALLATION	8
FLYWHEEL/TIMING BELT	9
CYLINDER HEAD/VALVES/OIL PUMP	10
CRANKCASE/CRANKSHAFT/PISTON	11
OIL CASE/STERN BRACKET/SWIVEL CASE	12
SHIFT LINKAGE	13
STEERING ROD/REMOTE CONTROL BOX	14
TILLER HANDLE	15
ELECTRICAL EQUIPMENT	16
OPERATION	17
WIRING DIAGRAMS	18

1. SPECIFICATIONS

2. DIMENSIONAL DRAWINGS

1. SPECIFICATIONS

DIMENSIONS AND WEIGHTS

Model	BF8D, BF9.9D, BF10D, BF8B, BF10B						
Description code	BF8D: BAAJ/BF9.9D, BF10D: BABJ/BF8B: BACJ/BF10B: BADJ						
Type	SH	SHS	SR	LH	LHS	LR	*1:XH
Overall length	610 mm (24.0 in)		600 mm (23.6 in)	610 mm (24.0 in)		600 mm (23.6 in)	610 mm (24.0 in)
Overall width	345 mm (13.6 in)						
Overall height	1,105 mm (43.5 in)			1,235 mm (48.6 in)			1,375 mm (54.1 in)
Dry weight	42.0 kg (92.6 lb)	46.5 kg (102.5 lb)	47.0 kg (103.6 lb)	44.5 kg (98.1 lb)	49.0 kg (108.0 lb)	49.5 kg (109.1 lb)	48.5 kg (106.9 lb)
Operating weight	43.4 kg (95.7 lb)	47.9 kg (105.6 lb)	48.4 kg (106.7 lb)	45.9 kg (101.2 lb)	50.4 kg (111.1 lb)	50.9 kg (112.2 lb)	49.9 kg (110.0 lb)
Transom height	433 mm (17.0 in)			563 mm (22.2 in)			703 mm (27.7 in)
Transom angle	5-stage adjustment (4°, 8°, 12°, 16°, 20°)						
Tilting angle	SH, SHS, LH, LHS type: 71° SR, LR, XH: 72°						
Swivel angle	45° right and left						

*1: BF8D and BF8B only.

Model	BFP8D, BFP9.9D, BFP10D, BFP8B, BFP10B					
Description code	BFP8D: BAAJ/BFP9.9D, BFP10D: BABJ/BFP8B: BACJ/BFP10B: BADJ					
Type	LH	LHS	LR	XH	XHS	XR
Overall length	610 mm (24.0 in)		600 mm (23.6 in)	610 mm (24.0 in)		600 mm (23.6 in)
Overall width	345 mm (13.6 in)					
Overall height	1,235 mm (48.6 in)			1,375 mm (54.1 in)		
Dry weight	44.5 kg (98.1 lb)	49.0 kg (108.0 lb)	49.5 kg (109.1 lb)	48.5 kg (106.9 lb)	53.0 kg (116.8 lb)	53.5 kg (117.9 lb)
Operating weight	45.9 kg (101.2 lb)	50.4 kg (111.1 lb)	50.9 kg (112.2 lb)	49.9 kg (110.0 lb)	54.4 kg (119.9 lb)	54.9 kg (121.0 lb)
Transom height	563 mm (22.2 in)			703 mm (27.7 in)		
Transom angle	5-stage adjustment (4°, 8°, 12°, 16°, 20°)					
Tilting angle	LH, LHS type: 71° LR, XH, XHS, XR: 72°					
Swivel angle	45° right and left					

ENGINE

Model	BF8D, BF8B, BFP8D, BFP8B	BF9.9D, BF10D, BF10B, BFP9.9D, BFP10D, BFP10B
Type	Water cooled 4-stroke, overhead valve, vertical twin	
Displacement	222 cm ³ (13.5 cu. in)	
Bore x stroke	58 x 42 mm (2.3 x 1.7 in)	
Rated horsepower	5.9 kW (8.0 PS) at 4,500 – 5,500 min ⁻¹ (rpm)	*1: 7.3 kW (9.9 PS) at 5,000 – 6,000 min ⁻¹ (rpm)
		*2: 7.4 kW (10 PS) at 5,000 – 6,000 min ⁻¹ (rpm)
Maximum torque	12.5 N·m (1.27 kgf·m, 9.18 lbf·ft) at 4,000 min ⁻¹ (rpm)	13.1 N·m (1.34 kgf·m, 9.67 lbf·ft) at 4,500 min ⁻¹ (rpm)
Compression ratio	9.0 : 1	
Fuel consumption	377 g (13.3 oz.)/kWh	394 g (13.9 oz.)/kWh
Cooling system	Forced water circulation by impeller pump with thermostat	
Ignition system	CDI	
Ignition timing	0° B.T.D.C. at 1,000 min ⁻¹ (rpm)	
Spark plug	CR5EH-9 (NGK), U16FER9 (DENSO)	
Carburetor	Horizontal butterfly valve type single carburetor	
Lubricating system	Forced lubrication by trochoid pump	
Oil capacity	1.0 ℓ (1.06 US qt, 0.88 Imp qt) at oil change	
	1.3 ℓ (1.37 US qt, 1.14 Imp qt) with oil filter replacement	
Recommended oil	SAE 10W-30, API Service classification SG/SH/SJ	
Starting system	Electric starter and recoil starter	
Stopping system	Ignition primary circuit ground	
Fuel used	Automotive unleaded gasoline (minimum 86 pump octane)	
Fuel tank capacity	Steel tank: 13 ℓ (3.4 US gal, 2.9 Imp gal)	
	Plastic tank: 12 ℓ (3.2 US gal, 2.6 Imp gal)	
Fuel pump	Mechanical plunger type	
Exhaust system	Under water type	

*1: BF9.9D and BFP9.9D only

*2: BF10D, BF10B, BFP10D and BFP10B only

LOWER UNIT

Model	BF8D, BF8B, BF9.9D, BF10D, BF10B	BFP8D, BFP8B, BFP9.9D, BFP10D, BFP10B	
Clutch	Dog clutch (Forward-neutral-reverse)		
Gear ratio	0.43 (12/28)		
Reduction type	Spiral bevel gear		
Gear case oil capacity	0.285 ℓ (0.27 US qt, 0.23 Imp qt)		
Propeller	Number of blades	4	4
	Diameter	235 mm (9.3 in)	254 mm (10 in)
	Pitch	S type: 229 mm (9.0 in) L, XL type: 203 mm (8.0 in)	165 mm (6.5 in)
	Rotating direction	Clockwise (viewed from rear)	

BF8•BF9.9•BF10

TYPES OF Honda BF8D/BF9.9D/BF10D/BF8B/BF10B/BFP8D/BFP9.9D/BFP10D/BFP8B/BFP10B OUTBOARD MOTOR

It may be necessary to refer to this chart for reference purposes when reading this manual.

Model	Type	Shaft length	Tiller handle	Remote control	Electric starter	Recoil starter	Charge coil	Stating enrichment system	
BF8D/ BF9.9D/ BF10D/ BF8B/ BF10B	SH	S	●			●	6A	Manual	
	SHS	S	●		●	●	12A	Automatic	
	SR	S		●	●	●	12A	Automatic	
	LH	L	●			●	6A	Manual	
	LHS	L	●		●	●	12A	Automatic	
	LR	L			●	●	●	12A	Automatic
	*1: XH	XL	●				●	6A	Manual
BFP8D/ BFP9.9D/ BFP10D/ BFP8B/ BFP10B	LH	L	●			●	6A	Manual	
	LHS	L	●		●	●	12A	Automatic	
	LR	L		●	●	●	12A	Automatic	
	XH	XL	●			●	6A	Manual	
	XHS	XL	●		●	●	12A	Automatic	
	XR	XL			●	●	●	12A	Automatic

*1: BF8D and BF8B only

S: Short shaft L: Long shaft XL: Extra long shaft

2. DIMENSIONAL DRAWINGS

Unit: mm (in)

Tiller Handle Type

Unit: mm (in)

Type	H	T
S	1,105 (43.5)	433 (17.0)
L	1,235 (48.6)	563 (22.2)
XL	1,375 (54.1)	703 (27.7)

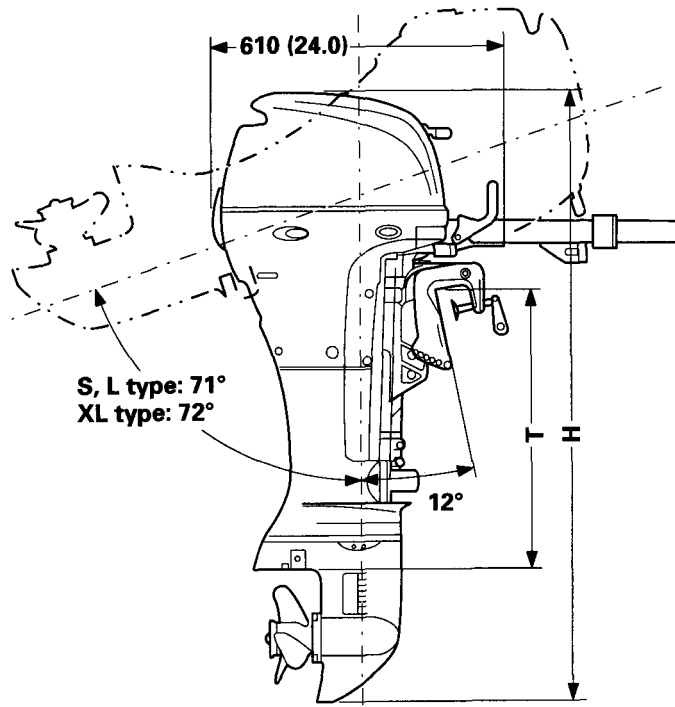
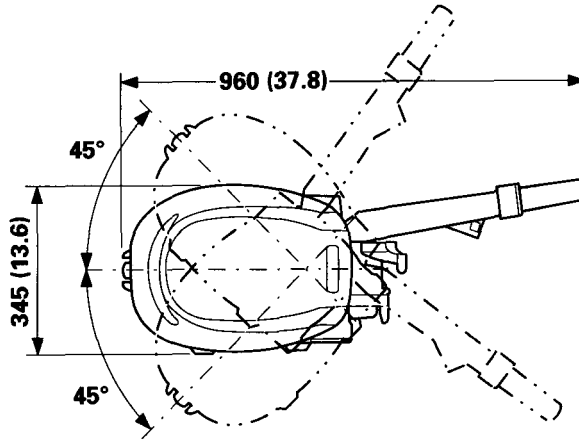

Remote Control Type

Unit: mm (in)

Unit: mm (in)		
Type	H	T
S	1,105 (43.5)	433 (17.0)
L	1,235 (48.6)	563 (22.2)
XL	1,375 (54.1)	703 (27.7)

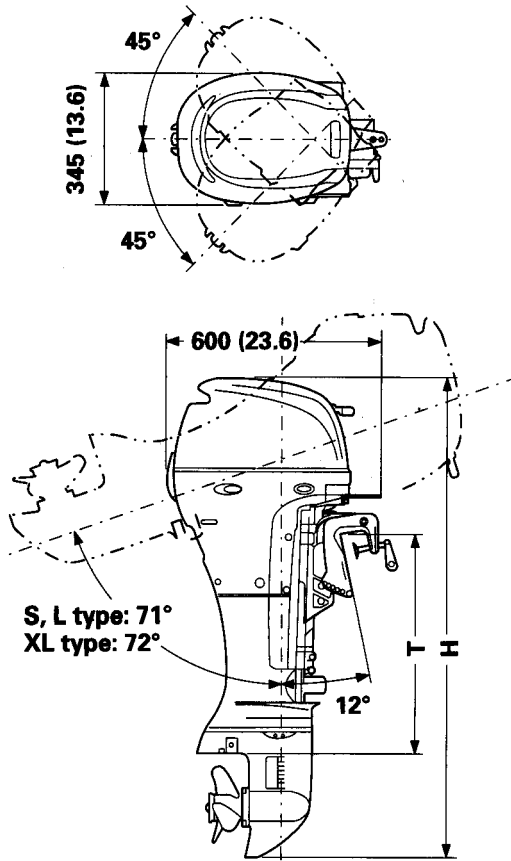

PROPELLER SHAFT DETAIL

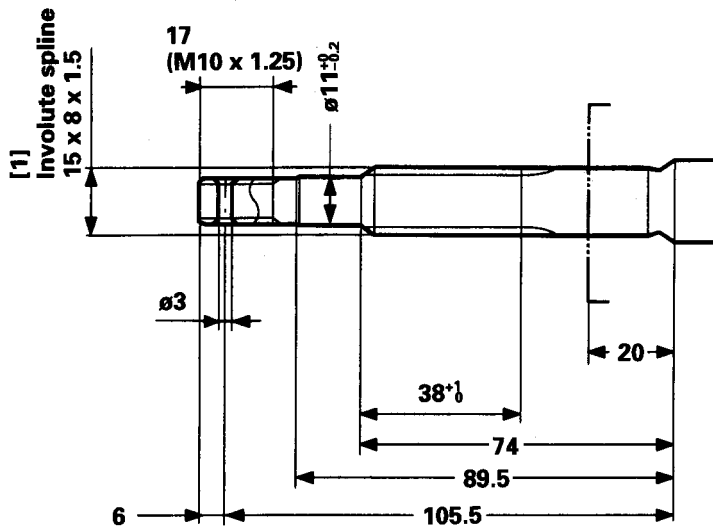

- | | |
|---------------------------------------|----------------------------|
| 1. THE IMPORTANCE OF PROPER SERVICING | 6. TORQUE VALUES |
| 2. IMPORTANT SAFETY PRECAUTIONS | 7. SPECIAL TOOLS |
| 3. SERVICE RULES | 8. TROUBLESHOOTING |
| 4. SERIAL NUMBER LOCATIONS | 9. CABLE & HARNESS ROUTING |
| 5. MAINTENANCE STANDARDS | 10. LUBRICATION POINTS |

1. THE IMPORTANCE OF PROPER SERVICING

Proper servicing is essential to the safety of the operator and the reliability of the outboard motor. Any error or oversight made by the technician while servicing can easily result in faulty operation, damage to the outboard motor, or injury to the operator.

⚠ WARNING

- **Improper servicing can cause an unsafe condition that can lead to serious injury or death.**
- **Follow the procedures and precautions in this shop manual carefully.**

Some of the most important precautions are given below. However, we cannot warn you of every conceivable hazard that can arise in performing maintenance or repairs. Only you can decide whether or not you should perform a given task.

⚠ WARNING

- **Failure to follow maintenance instructions and precautions can cause you to be seriously hurt or killed.**
- **Follow the procedures and precautions in this shop manual carefully.**

2. IMPORTANT SAFETY PRECAUTIONS

Be sure you have a clear understanding of all basic shop safety practices and that you are wearing appropriate clothing and safety equipment. When performing maintenance or repairs, be especially careful of the following:

- **Read the instructions before you begin, and be sure you have the tools and skills required to perform the tasks safely.**
Be sure the engine is off before you begin any maintenance or repairs. This will reduce the possibility of several hazards:
- **Carbon monoxide poisoning from engine exhaust.**
Be sure there is adequate ventilation whenever you run the engine.
- **Burns from hot parts.**
Let the engine cool before you touch it.
- **Injury from moving parts.**
Do not run the engine unless the instruction tells you to do so. Even then, keep your hands, fingers, and clothing away.

To reduce the possibility of a fire or explosion, be careful when working around gasoline. Use only a nonflammable solvent, not gasoline, to clean parts. Keep all cigarettes, sparks, and flames away from the battery and all fuel-related parts.

3. SERVICE RULES

1. Use genuine Honda or Honda-recommended parts and lubricants or their equivalents. Parts that do not meet Honda's design specifications may damage the unit.
2. Use the special tools designed for the product.
3. Install new gaskets, O-rings, etc. when assembling.
4. When torquing bolts or nuts, begin with larger-diameter or inner bolts first, and tighten to the specified torque diagonally, unless a particular sequence is specified.
5. Clean parts in cleaning solvent upon disassembly. Lubricate any sliding surfaces before assembly.
6. After assembly, check all parts for proper installation and operation.
7. Many screws used in this machine are self-tapping. Be aware that cross-threading or overtightening these screws will strip the female threads and ruin the hole.
8. Use only metric tools when servicing this unit. Metric bolts, nuts and screws are not interchangeable with nonmetric fasteners. The use of incorrect tools and fasteners will damage the unit.
9. Follow the instructions represented by these symbols when they are used.



: Apply oil.



: Use special tool.



: Apply grease

○ x ○ (○) : Indicates the type, length, and number of the flange bolt used.

P. : Indicates the reference page.



(Molybdenum disulfide oil) : Use molybdenum oil solution (mixture of the engine oil and molybdenum grease with the ratio 1:1).

4. SERIAL NUMBER LOCATION

The engine serial number is stamped on the left front of the cylinder block and the frame serial number is located on the swivel case. Refer to these numbers when ordering parts and when making technical inquiries.

FRAME SERIAL NUMBER

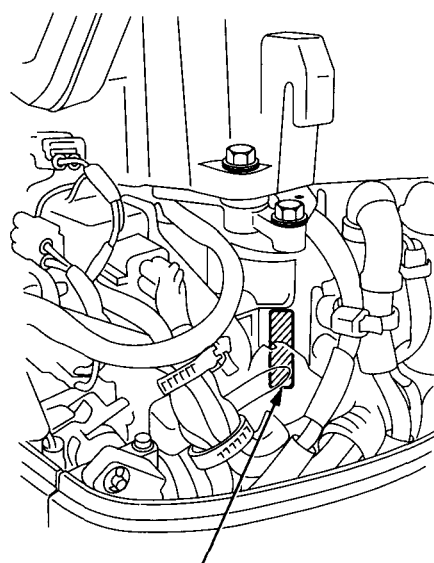
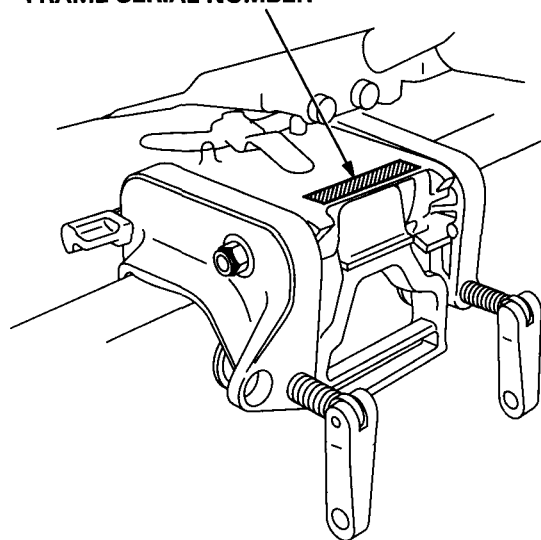

ENGINE SERIAL NUMBER

5. MAINTENANCE STANDARDS

• ENGINE

Part	Item		Standard	Service limit
Engine	Idle speed (in neutral)		900 ± 50 min ⁻¹ (rpm)	—
	Recommended full throttle rpm		[*1]: 4,500 – 5,500 min ⁻¹ (rpm)	—
			[*2]: 5,000 – 6,000 min ⁻¹ (rpm)	—
Cylinder compression		1.23 – 1.42 MPa (12.5 – 14.5 kgf/cm ² , 178 – 206 psi) at 600 min ⁻¹ (rpm)	—	
Cylinder heads	Warpage		0.05 mm (0.002 in) max.	0.10 mm (0.004 in)
	Valve seat width	IN/EX	0.9 – 1.1 mm (0.035 – 0.043 in)	2.0 mm (0.08 in)
	Camshaft journal I.D.	No. 1	20.000 – 20.021 mm (0.7874 – 0.7882 in)	20.05 mm (0.789 in)
Valves	Clearance	IN	0.15 – 0.19 mm (0.006 – 0.007 in)	—
		EX	0.21 – 0.25 mm (0.008 – 0.010 in)	—
	Stem O.D.	IN	4.975 – 4.990 mm (0.1959 – 0.1965 in)	4.95 mm (0.195 in)
		EX	4.955 – 4.970 mm (0.1951 – 0.1957 in)	4.93 mm (0.194 in)
Valve guides	Guide I.D.	IN/EX	5.000 – 5.012 mm (0.1969 – 0.1973 in)	5.04 mm (0.198 in)
	Stem-to-guide clearance	IN	0.010 – 0.037 mm (0.0004 – 0.0015 in)	0.07 mm (0.003 in)
		EX	0.030 – 0.067 mm (0.0012 – 0.0026 in)	0.12 mm (0.005 in)
Valve springs	Free length		33.28 mm (1.310 in)	32.0 mm (1.26 in)
Rocker arms, rocker arm shaft	Shaft O.D.		12.962 – 12.980 mm (0.5103 – 0.5110 in)	12.92 mm (0.509 in)
	Arm I.D.		13.000 – 13.018 mm (0.5118 – 0.5125 in)	13.04 mm (0.513 in)
	Shaft-to-rocker arm clearance		0.020 – 0.056 mm (0.0008 – 0.0022 in)	0.07 mm (0.003 in)
Camshaft	Camshaft axial play		0.05 – 0.30 mm (0.002 – 0.012 in)	0.4 mm (0.016 in)
	Cam height (IN/EX)		[*1]: 21.916 – 22.076 mm (0.8628 – 0.8691 in)	21.716 mm (0.8550 in)
			[*2]: 23.396 – 23.556 mm (0.9211 – 0.9274 in)	23.196 mm (0.9132 in)
	Journal O.D.	No. 1	19.959 – 19.980 mm (0.7858 – 0.7866 in)	19.93 mm (0.785 in)
		Oil pump	15.966 – 15.984 mm (0.6286 – 0.6293 in)	15.94 mm (0.628 in)
Journal-to-shaft clearance	No. 1	0.020 – 0.062 mm (0.0008 – 0.0024 in)	0.08 mm (0.003 in)	
Oil pump	Rotor tip clearance		0.15 mm (0.006 in) max.	0.20 mm (0.008 in)
	Outer rotor-to-body clearance		0.15 – 0.21 mm (0.006 – 0.008 in)	0.26 mm (0.010 in)
	Rotor-to-pump body side clearance		0.04 – 0.09 mm (0.002 – 0.004 in)	0.12 mm (0.005 in)
	Pump body I.D.		40.71 – 40.74 mm (1.603 – 1.604 in)	40.76 mm (1.605 in)
	Pump body depth		12.04 – 12.07 mm (0.474 – 0.475 in)	12.11 mm (0.477 in)
	Outer rotor height		11.98 – 12.00 mm (0.4717 – 0.4724 in)	11.96 mm (0.471 in)
	Camshaft journal I.D.		16.000 – 16.018 mm (0.6299 – 0.6306 in)	16.05 mm (0.632 in)
	Pump body-to-camshaft clearance		0.016 – 0.052 mm (0.0006 – 0.0020 in)	0.07 mm (0.003 in)
Fuel pump	Pump arm I.D.		13.000 – 13.080 mm (0.5118 – 0.5150 in)	13.10 mm (0.516 in)
	Shaft-to-pump arm clearance		0.020 – 0.118 mm (0.0008 – 0.0046 in)	0.13 mm (0.005 in)
Cylinders	Sleeve I.D.		58.000 – 58.015 mm (2.2835 – 2.2841 in)	58.055 mm (2.2856 in)

[*1]: BF8D, BF8B, BFP8D and BFP8B only

[*2]: BF9.9D, BF10D, BF10B, BFP9.9D, BFP10D and BFP10B only

ENGINE (continued)

Parts	Item	Standard	Service limit	
Pistons	Skirt O.D.	57.970 – 57.990 mm (2.2823 – 2.2831 in)	57.92 mm (2.280 in)	
	Piston-to-cylinder clearance	0.010 – 0.045 mm (0.0004 – 0.0015 in)	0.10 mm (0.004 in)	
	Piston pin bore I.D.	16.002 – 16.008 mm (0.6300 – 0.6302 in)	16.02 mm (0.638 in)	
Piston pins	Piston pin O.D.	15.994 – 16.000 mm (0.6297 – 0.6299 in)	15.97 mm (0.629 in)	
	Piston-to-piston pin clearance	0.002 – 0.014 mm (0.0001 – 0.0006 in)	0.04 mm (0.002 in)	
Piston rings	Side clearance	Top/second	0.025 – 0.055 mm (0.0010 – 0.0022 in)	0.10 mm (0.004 in)
		Oil	0.055 – 0.140 mm (0.0022 – 0.0055 in)	0.20 mm (0.008 in)
	End gap	Top	0.15 – 0.30 mm (0.006 – 0.012 in)	0.5 mm (0.02 in)
		Second	0.35 – 0.50 mm (0.014 – 0.020 in)	0.7 mm (0.03 in)
		Oil	0.20 – 0.80 mm (0.008 – 0.031 in)	1.0 mm (0.04 in)
Thickness	Top/second	1.175 – 1.190 mm (0.0463 – 0.0469 in)	1.08 mm (0.043 in)	
Connecting rods	Small end I.D.	16.007 – 16.022 mm (0.6302 – 0.6308 in)	16.05 mm (0.632 in)	
	Big end I.D.	28.020 – 28.033 mm (1.1031 – 1.1037 in)	28.06 mm (1.105 in)	
	Big end oil clearance	0.020 – 0.046 mm (0.0008 – 0.0018 in)	0.06 mm (0.002 in)	
	Big end side clearance	0.10 – 0.60 mm (0.004 – 0.024 in)	0.7 mm (0.03 in)	
Crankshaft	Main journal O.D.	29.984 – 29.993 mm (1.1805 – 1.1808 in)	29.96 mm (1.180 in)	
	Crank pin O.D.	27.987 – 28.000 mm (1.1018 – 1.1024 in)	27.96 mm (1.101 in)	
	Main journal oil clearance	0.015 – 0.037 mm (0.0006 – 0.0015 in)	0.06 mm (0.002 in)	
Carburetor	Main jet	[*1]: #105	——	
		[*2]: #98	——	
	Pilot screw opening	See page 6-8.	——	
	Float height	13.5 mm (0.53 in)	——	

[*1]: BF8D, BF9.9D, BF10D, BFP8D, BFP9.9D and BFP10D only

[*2]: BF8B, BF10B, BFP8B and BFP10B only

ELECTRICAL

Parts	Item	Standard	Service limit
Spark plug	Gap	0.8 – 0.9 mm (0.031 – 0.035 in)	——
Ignition coil	Primary coil resistance	0.35 – 0.43 Ω	——
	Secondary coil resistance (with plug caps)	23.0 – 34.8 kΩ	——
Starter motor	Brush length	12.5 mm (0.49 in)	8.5 mm (0.33 in)
	Mica depth	——	0.2 mm (0.01 in)
Charge coil	Resistance	12A charge coil	0.2 – 0.3 Ω
		6A charge coil	0.23 – 0.29 Ω
Exciter coil	Resistance	Electric starter type	5.0 – 7.4 Ω
		Recoil starter type	6.1 – 7.5 Ω
Pulse generator	Resistance	351 – 429 Ω	——
SE thermal valve coil	Resistance	1.2 – 1.8 Ω	——

LOWER UNIT

Parts	Item	Standard	Service limit
Propeller shaft	Shaft O.D.	16.973 – 16.984 mm (0.6682 – 0.6687 in)	16.95 mm (0.667 in)
Forward gear	I.D.	17.000 – 17.018 mm (0.6693 – 0.6700 in)	17.04 mm (0.671 in)
Vertical shaft	Shaft O.D.	S and L type	12.976 – 12.995 mm (0.5108 – 0.5116 in)
		XL type	14.989 – 15.000 mm (0.5901 – 0.5906 in)

6. TORQUE VALUES

• Engine

Item	Thread dia. x pitch	Torque		
		N·m	kgf·m	lbf·ft
Crankcase cover bolts	M6 x 1.0	14	1.4	10
Oil pressure switch	PT1/8 (Apply sealant to the threads.)	8	0.8	5.8
Oil drain bolt	M8 x 1.25	6	0.6	4.3
Oil filter cartridge	M20 x 1.5	12	1.2	9
Spark plugs	M10 x 1.0	12	1.2	9
Cylinder head bolts (L = 83 mm)	M8 x 1.25 (Apply oil to the threads.)	26	2.7	20
Cylinder head bolts (L = 40 mm)	M8 x 1.25	24	2.4	17
Valve adjusting lock nuts	M5 x 0.5	8	0.8	5.8
Connecting rod bolts	M6 x 1.0	12	1.2	9
Timing belt driven pulley bolt	M6 x 1.0	16	1.6	12
Recoil starter pulley bolts	M6 x 1.0	11	1.1	8
Flywheel nut	M14 x 1.5 (Apply oil to the threads.)	88	9.0	65
Timing belt drive pulley lock nut	M24 x 1.0 (Apply oil to the threads.)	54	5.5	40
Oil pump cover bolts	M5 x 0.8	5	0.5	3.6
Oil pump bolts	M6 x 1.0	11	1.1	8
Silencer bolts	M6 x 1.0	9	0.9	6.5
Silencer cover bolt	M6 x 1.0	10	1.0	7
Oil case bolts	M8 x 1.25	24	2.4	17
Thermo sensor	M12 x 1.5	18	1.8	13
Exhaust chamber cover bolts	M6 x 1.0	11	1.1	8

• Gear Case

Item	Thread dia. x pitch	Torque		
		N·m	kgf·m	lbf·ft
Gear case bolts and nuts	M6 x 1.0	12	1.2	9
Propeller 10 mm crown head nut	M10 x 1.25	See page 4-2		
Propeller shaft holder bolts	M6 x 1.0	12	1.2	9
Oil level bolt	M8 x 1.25	3.5	0.35	2.5
Oil drain bolt	M8 x 1.25	3.5	0.35	2.5
Water pump housing bolts	M6 x 1.0	12	1.2	9
Impeller housing bolts	M6 x 1.0	11	1.1	8
Water screen nuts	M5 x 0.8	1	0.1	0.7
Anode metal nut	M6 x 1.0	10	1.0	7
Shift rod B lock nut	M6 x 1.0	10	1.0	7

• Cover

Item	Thread dia. x pitch	Torque		
		N·m	kgf·m	lbf·ft
Left, right engine under cover screw	M5 x 0.8	4.5	0.45	3.3

- **Extension Case/Mount Rubber**

Item	Thread dia. x pitch	Torque		
		N-m	kgf-m	lbf-ft
Extension case bolts	M8 x 1.25	24	2.4	17
Upper mount rubber stay bolt	M6 x 1.0	12	1.2	9
Lower mount rubber bolts	M8 x 1.25	22	2.2	16
Lower mount rubber cover bolts	M6 x 1.0	12	1.2	9
Extension case stud bolts (XL type)	M6 x 1.0	12	1.2	9
Upper mount rubber bolt	M10 x 1.25	38	3.9	28
Steering friction lever lock nut	M8 x 0.75	2.5	0.25	1.8

- **Stern Bracket**

Item	Thread dia. x pitch	Torque		
		N-m	kgf-m	lbf-ft
Tilting bolt lock nut (Except XL and remote control type)	M8 x 1.25	24	2.4	17
Tilting shaft nut (XL and remote control type)	7/8-14UNF	17	1.7	12
Stern bracket nut (XL and remote control type)	M8 x 1.25	21	2.1	15

- **Tiller Handle**

Item	Thread dia. x pitch	Torque		
		N-m	kgf-m	lbf-ft
Tiller handle bracket bolts	M10 x 1.25	33	3.4	25
Tiller handle pivot nut	M8 x 1.25	8	0.8	5.8
Shift shaft plate screws	M5 x 0.8	1.5	0.15	1.1
Shift lever pivot bolt	M6 x 1.0	12	1.2	9
Emergency stop switch nut	M16 x 1.0	1.5	0.15	1.1
Throttle cable lock nut	M6 x 1.0	4.5	0.45	3.3
Starter switch nut	M16 x 1.0	1.5	0.15	1.1

- **Frame/Electrical Equipment**

Item	Thread dia. x pitch	Torque		
		N-m	kgf-m	lbf-ft
Neutral switch nut	M20 x 1.0	2.5	0.25	1.8
Neutral start cable nut	M6 x 1.0	4.5	0.45	3.3
Starter magnetic switch bolts	M6 x 1.0	7	0.7	5.1
Starter cord terminal nut	M6 x 1.0	5	0.5	3.6
Starter cable terminal nut	M6 x 1.0	6.5	0.65	4.7
Choke cable nut	M11 x 1.25	2.5	0.25	1.8

- Use standard torque values (P. 2-8) of fasteners that are not listed in this table.

STANDARD TORQUE

Item	Thread size	Torque		
		N-m	kgf-m	lbf-ft
Screw	4 mm	2	0.2	1.4
	5 mm	4.2	0.42	3.0
	6 mm	9	0.9	6.5
Hex. bolt and nut	5 mm	5.2	0.52	3.8
	6 mm	10	1.0	7
	8 mm	21.5	2.15	15.5
	10 mm	34	3.5	25
	12 mm	54	5.5	40
Flange bolt and nut	6 mm	12	1.2	9
	8 mm	26	2.7	20
	10 mm	39	4.0	29
	12 mm	59	6.0	43
SH (small head flange) bolt	6 mm	12	1.2	9
CT (self tapping) bolt	5 mm	5.5	0.55	4.0
	6 mm	12	1.2	9

7. SPECIAL TOOLS

	Tool name	Tool number	Application
1.	Float level gauge	07401 – 0010000	Carburetor float level inspection
2.	Oil pressure gauge attachment	07406 – 0030000	Oil pressure inspection
3.	Oil pressure gauge set	07506 – 3000000	Oil pressure inspection
4.	Remover weigth	07741 – 0010201	Constituent part of the tools 25, 26 and 33
5.	Attachment, 42 x 47 mm	07746 – 0010300	6005 radial ball bearing installation, 25 x 47 x 15 taper roller bearing (outer race) installation (XL type), forward bevel gear bearing installation (S and L types)
6.	Attachment, 24 x 26 mm	07746 – 0010700	17 mm water seal installation, 15 x 24 x 5 mm water seal installation (XL type)
7.	Attachment, 22 x 24 mm	07746 – 0010800	17 x 24 x 20 mm needle bearing removal, 13 mm water seal installation
8.	Inner driver	07746 – 0030100	25 x 47 x 15 taper roller bearing (inner race) installation (XL type)
9.	Attachment, 25 mm inner	07746 – 0030200	25 x 47 x 15 taper roller bearing (inner race) installation (XL type)
10.	Pilot, 15 mm	07746 – 0040300	15 x 21 x 12 mm needle bearing installation (XL type), 15 x 24 x 5 mm water seal installation (XL type)
11.	Pilot, 17 mm	07746 – 0040400	17 x 24 x 20 mm needle bearing removal/ installation, 17 mm water seal installation
12.	Pilot, 25 mm	07746 – 0040600	6005 radial ball bearing installation, forward bevel gear bearing removal (S and L types)
13.	Pilot, 13 mm	07746 – 0041500	13 x 15 x 15 mm bushing removal/installation (S and L types), 13 mm water seal installation
14.	Driver	07749 – 0010000	Driver for 5, 6, 7, 10, 11, 12 and 13
15.	Valve spring compressor	07757 – 0010000	Valve cotter removal/installation
16.	Valve seat cutter, 45° 27.5 mm	07780 – 0010200	Valve seat reconditioning (IN)
17.	Valve seat cutter, 45° 22 mm	07780 – 0010701	Valve seat reconditioning (EX)
18.	Valve seat cutter, 32° 25 mm	07780 – 0012000	Valve seat reconditioning (EX)
19.	Valve seat cutter, 32° 30 mm	07780 – 0012200	Valve seat reconditioning (IN)
20.	Valve seat cutter, 60° 22 mm	07780 – 0014202	Valve seat reconditioning (EX)
21.	Valve seat cutter, 60° 26 mm	07780 – 0014500	Valve seat reconditioning (IN)
22.	Cutter holder 5.0 mm	07781 – 0010400	Valve seat reconditioning (IN/EX)
23.	Valve adjusting wrench, 3 mm	07908 – KE90200	Valve clearance inspection
24.	Remover handle	07936 – 3710100	Constituent part of the tools 32
25.	Bearing remover, 15 mm	07936 – KC10500	15 x 21 x 12 mm needle bearing removal (XL type)
26.	Bearing remover, 25 mm	07936 – ZV10100	6005 radial ball bearing removal, forward bevel gear bearing removal (S and L types)
27.	Valve guide driver, 5.0 mm	07942 – 8920000	Valve guide removal/installation
28.	Needle bearing driver	07946 – KA50000	15 x 21 x 16 mm needle bearing removal/ installation (XL type)
29.	Driver, 15 x 280 mm	07949 – 3710001	17 x 24 x 20 mm needle bearing removal, 25 x 47 x 15 taper roller bearing (outer race) installation (XL type), forward bevel gear bearing installation (S and L types)

	Tool name	Tool number	Application
30.	Valve guide reamer, 5.010 mm	07984 – MA60001	Valve guide reaming (IN/EX)
31.	Oil filter wrench	07HAA – PJ70100	Oil filter removal/installation
32.	Pilot screw wrench	07KMA – MS60101	Pilot screw adjustment (Bodensee type only)
33.	Bearing race puller	07LPC – ZV30100	25 x 47 x 15 taper roller bearing (outer race) removal (XL type) [Puller jaws of the bearing race puller (07LPC – ZV30100) are removed and replaced with the puller jaws of part number 07WPC – ZW50100.]
34.	Puller jaws, 25 mm	07WPC – ZW50100	25 x 47 x 15 taper roller bearing (outer race) removal (XL type)
35.	30 mm lock nut wrench	07ZPA – ZW90100	24 mm lock nut removal/installation
36.	Crankshaft holder	07ZPB – ZW90100	24 mm lock nut removal/installation
37.	Driver, 13 x 325 mm	07ZPF – ZW90100	13 x 18 x 20 mm bushing removal/installation (S and L types)
38.	Driver, 15/13 x 30 mm	07ZPF – ZW90200	13 x 15 x 15 mm bushing removal/installation (S and L types)
39.	Driver, 14.5 x 18.5 mm	07ZPF – ZW90300	17 x 24 x 20 mm needle bearing installation, 15 x 21 x 12 mm needle bearing installation (XL type)

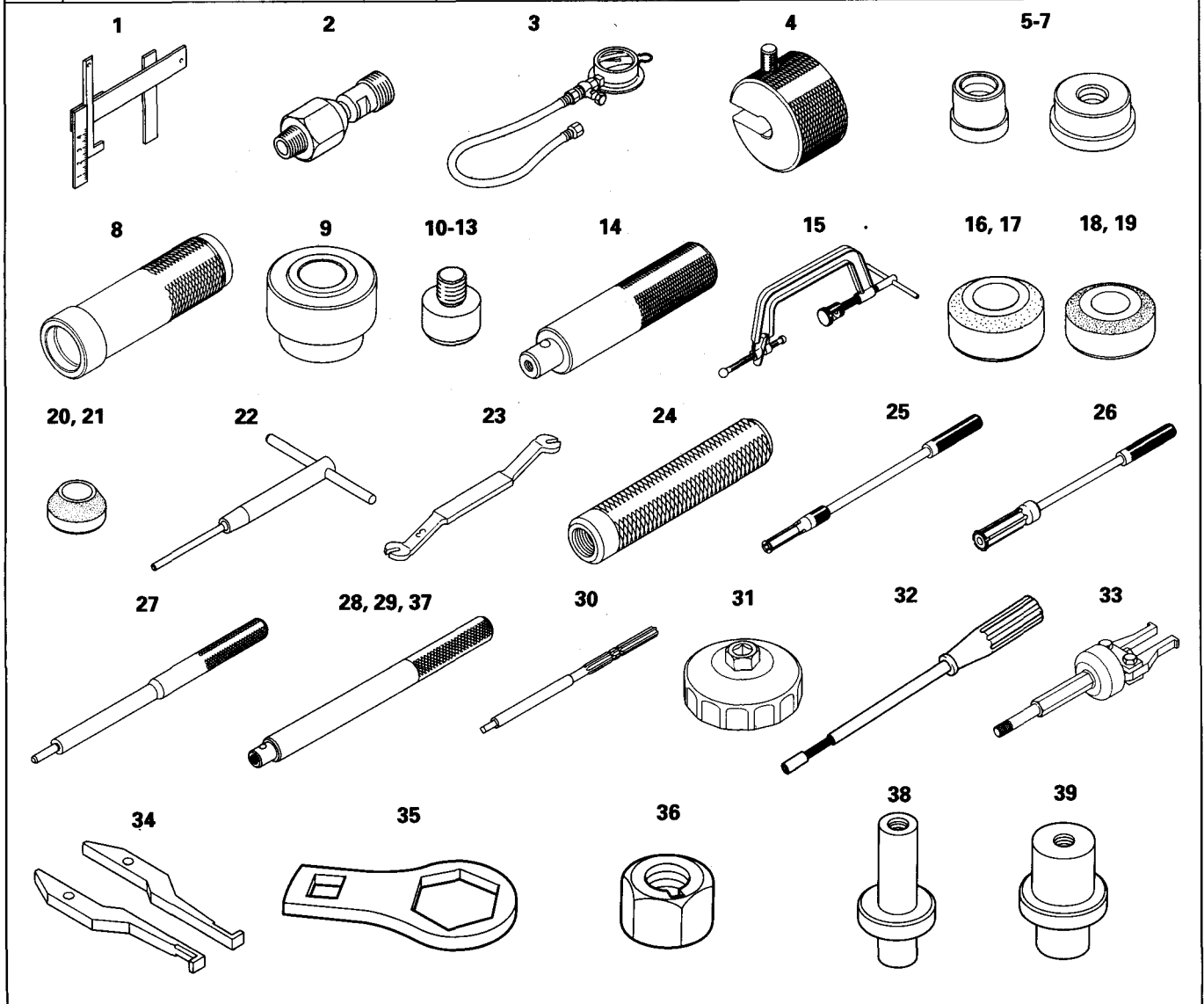

6. TROUBLESHOOTING

a. ENGINE

• Hard Starting

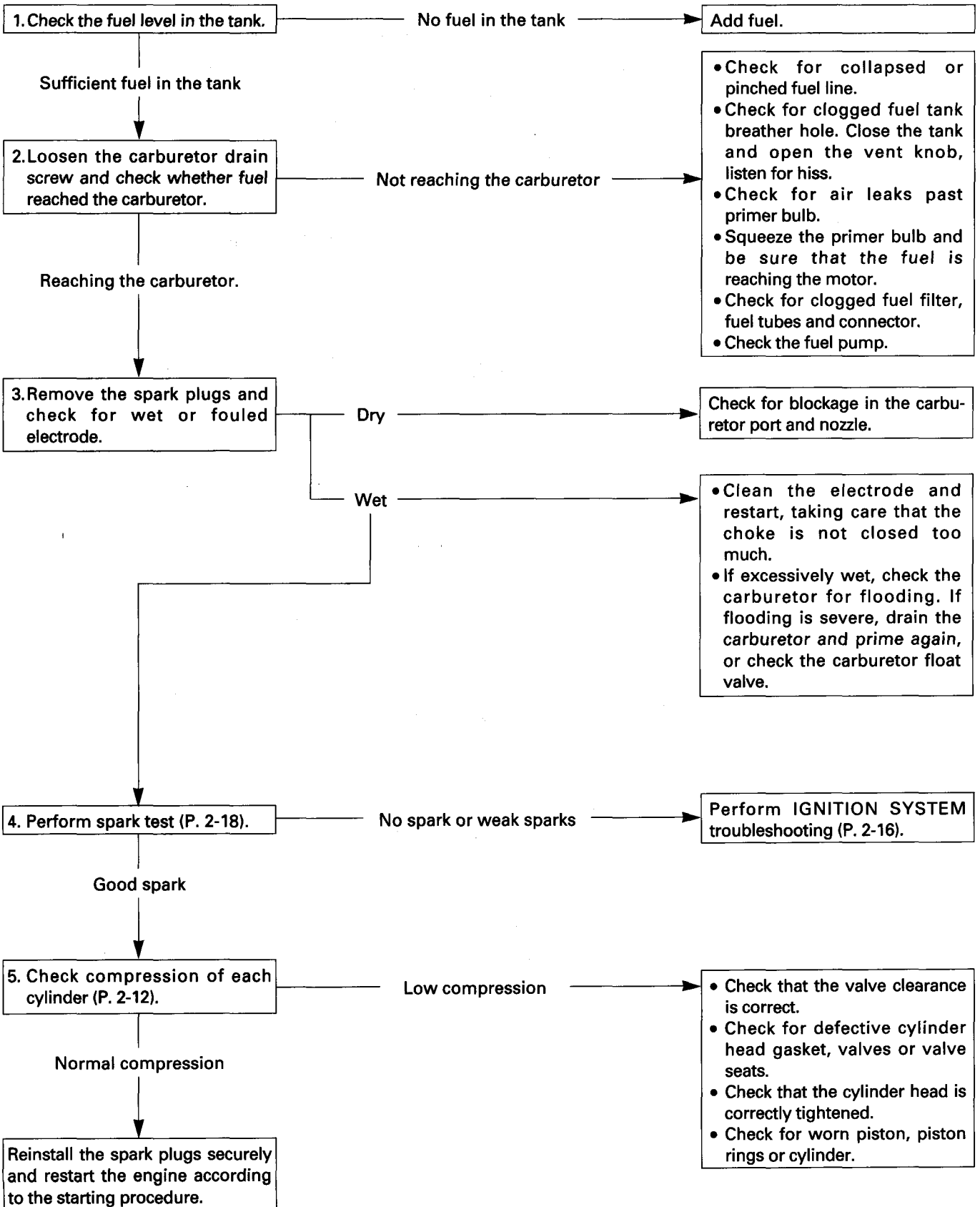

CYLINDER COMPRESSION CHECK

- 1) Shift the gear into the neutral position.
- 2) Disengage the emergency stop switch clip from the emergency stop switch.
- 3) Remove the engine cover and both spark plugs.
- 4) Install a compression gauge in the No. 1 cylinder plug hole.
- 5) Disconnect the remote control throttle cable from the throttle arm (Remote control type only).
- 6) Manually hold the throttle arm or throttle lever in the full open position.
- 7) Electric starter type: Turn the starter motor using the starter switch (Tiller handle type) or ignition switch (Remote control type) until stable compression is obtained.
 - Do not operate the starter motor for more than 5 seconds at one try. If stable compression is not obtained within 5 seconds, stop the starter motor and wait for 10 – 20 seconds, and repeat the operation again.

Recoil starter type: Pull the recoil starter several times until stable compression is obtained.

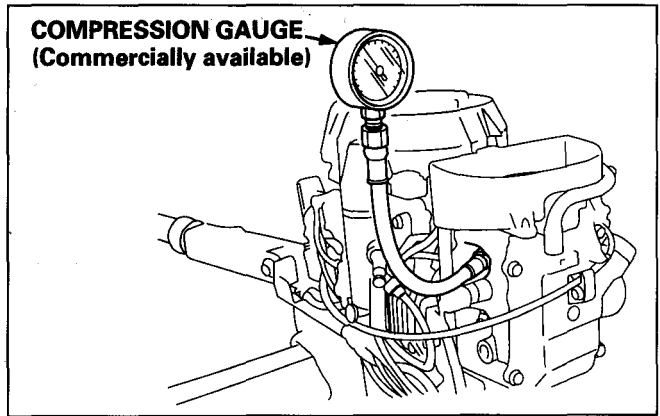

Cylinder compression	1.23 – 1.42 MPa (12.5 – 14.5 kgf/cm ² , 178 – 206 psi) at 600 min ⁻¹ (rpm)
----------------------	--------------------------------------------------------------------------------------------------------

- 8) Reinstall the compression gauge in the No. 2 cylinder plug hole and repeat steps 6 and 7.
- 9) After inspection, reinstall the removed parts in the reverse order of removal.

• Engine Does Not Run Smoothly

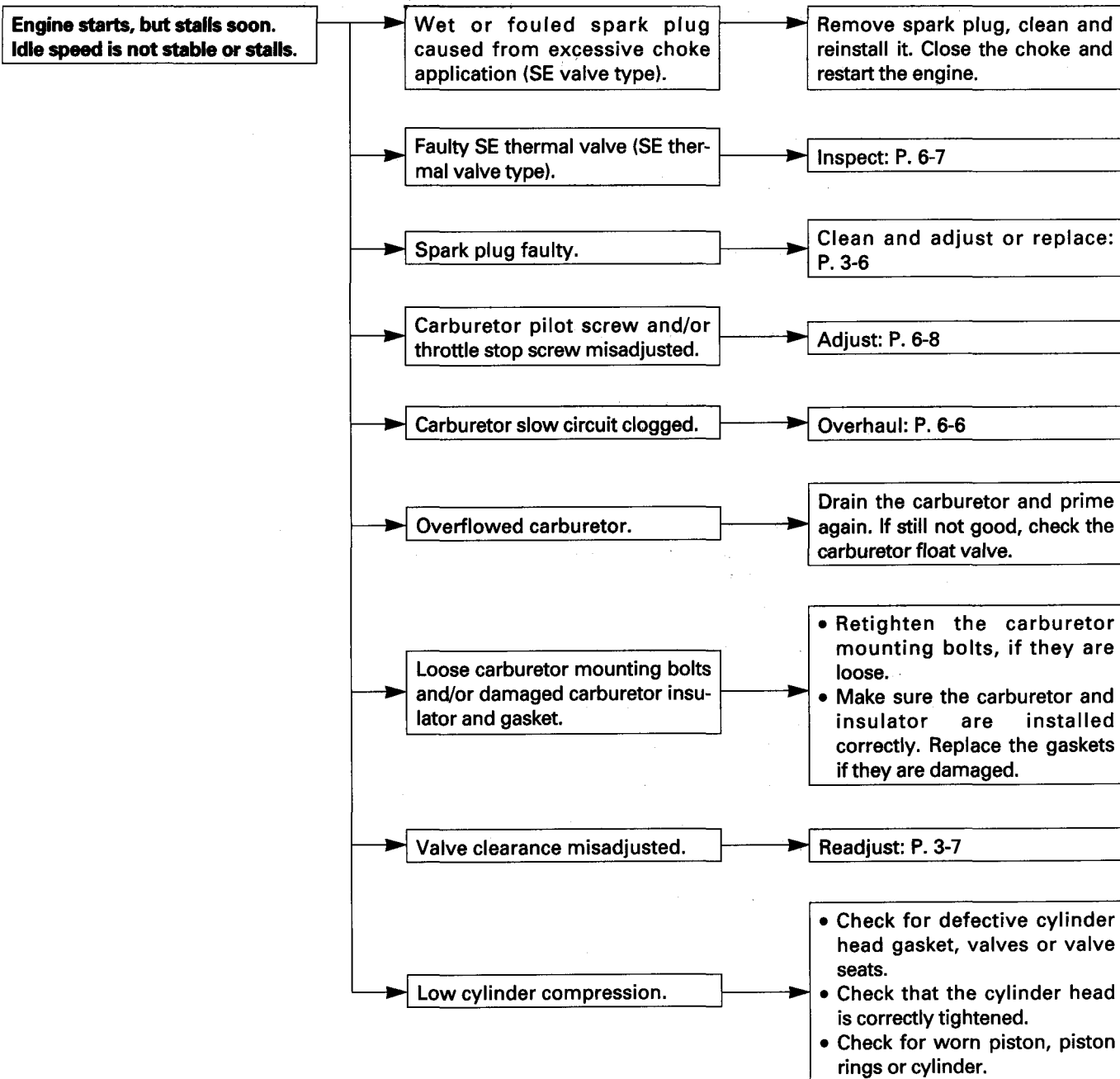

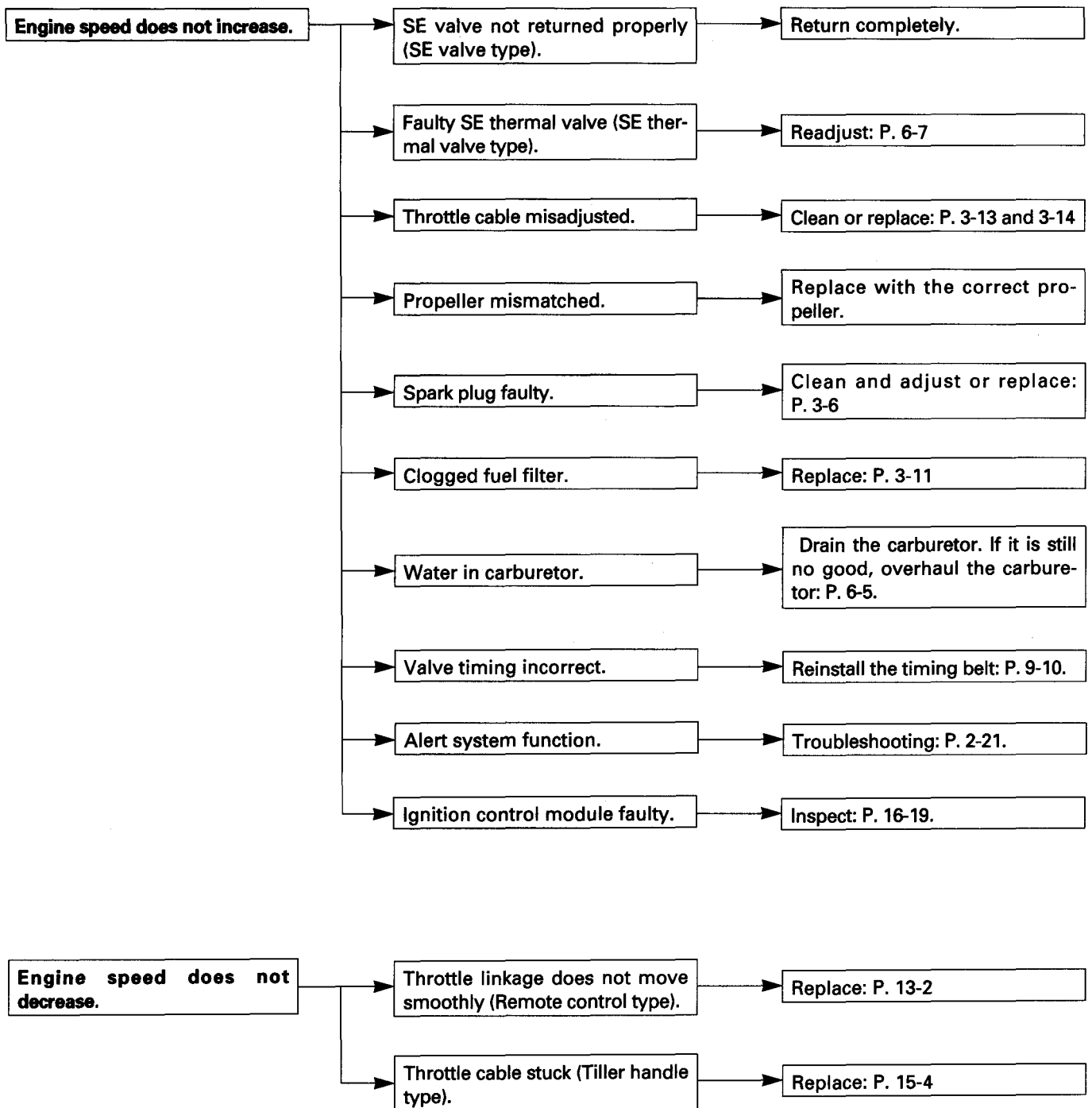

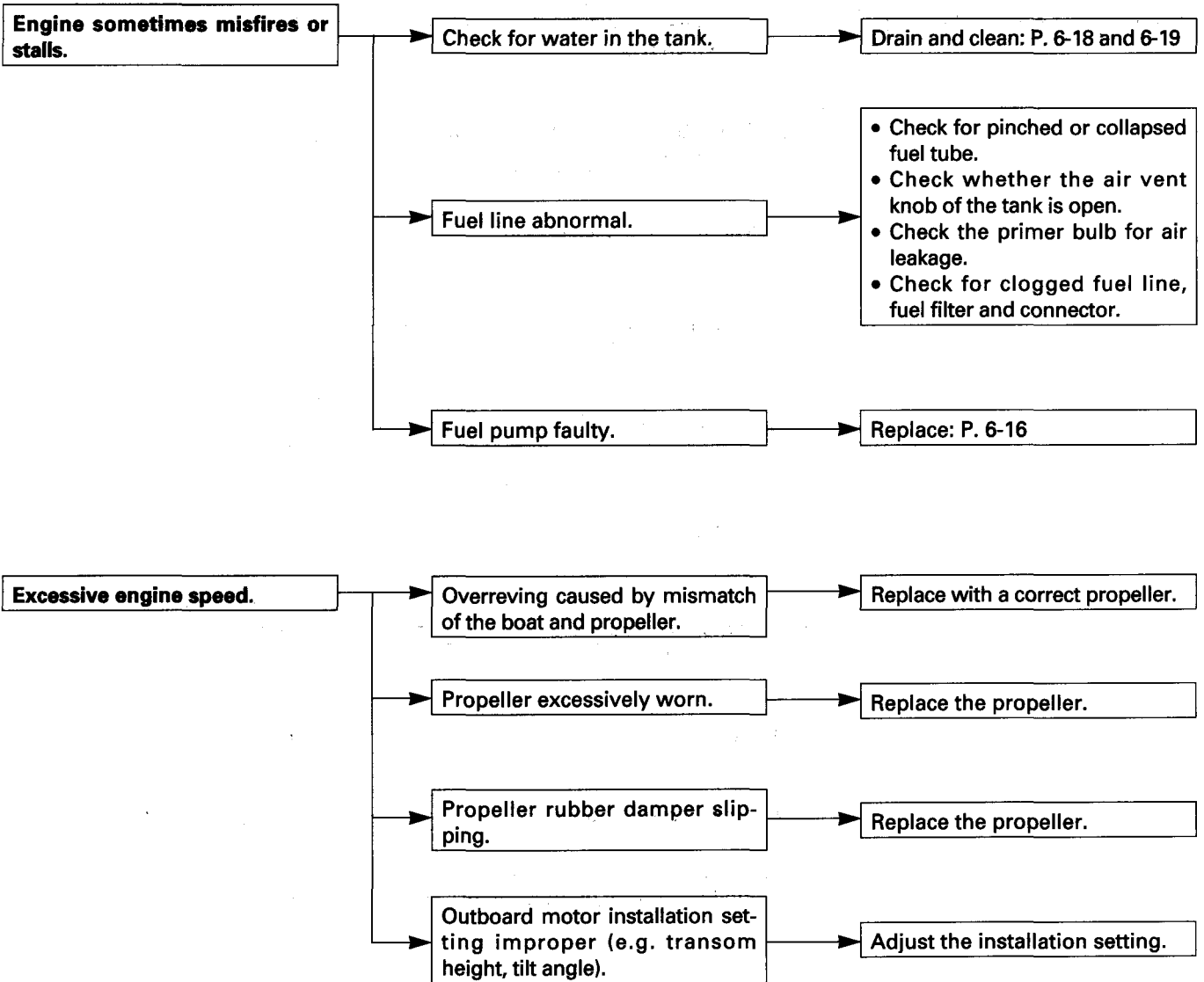

b. IGNITION SYSTEM

These outboard motors are equipped with an engine overrev limiter which is provided in the ignition control module.

The overrev limiter is activated when the engine rpm exceeds (BF9.9D, BFP9.9D, BF10D, BFP10D, BF10B, BFP10B: 6,300 rpm, BF8D, BFP8D, BF8B, BFP8B: 5,800 rpm). When activated the sparks are emitted to the No. 1 and No. 2 cylinders. The overrev limiter may be activated under such conditions as light propeller load or propeller ventilation.

• Hard Starting

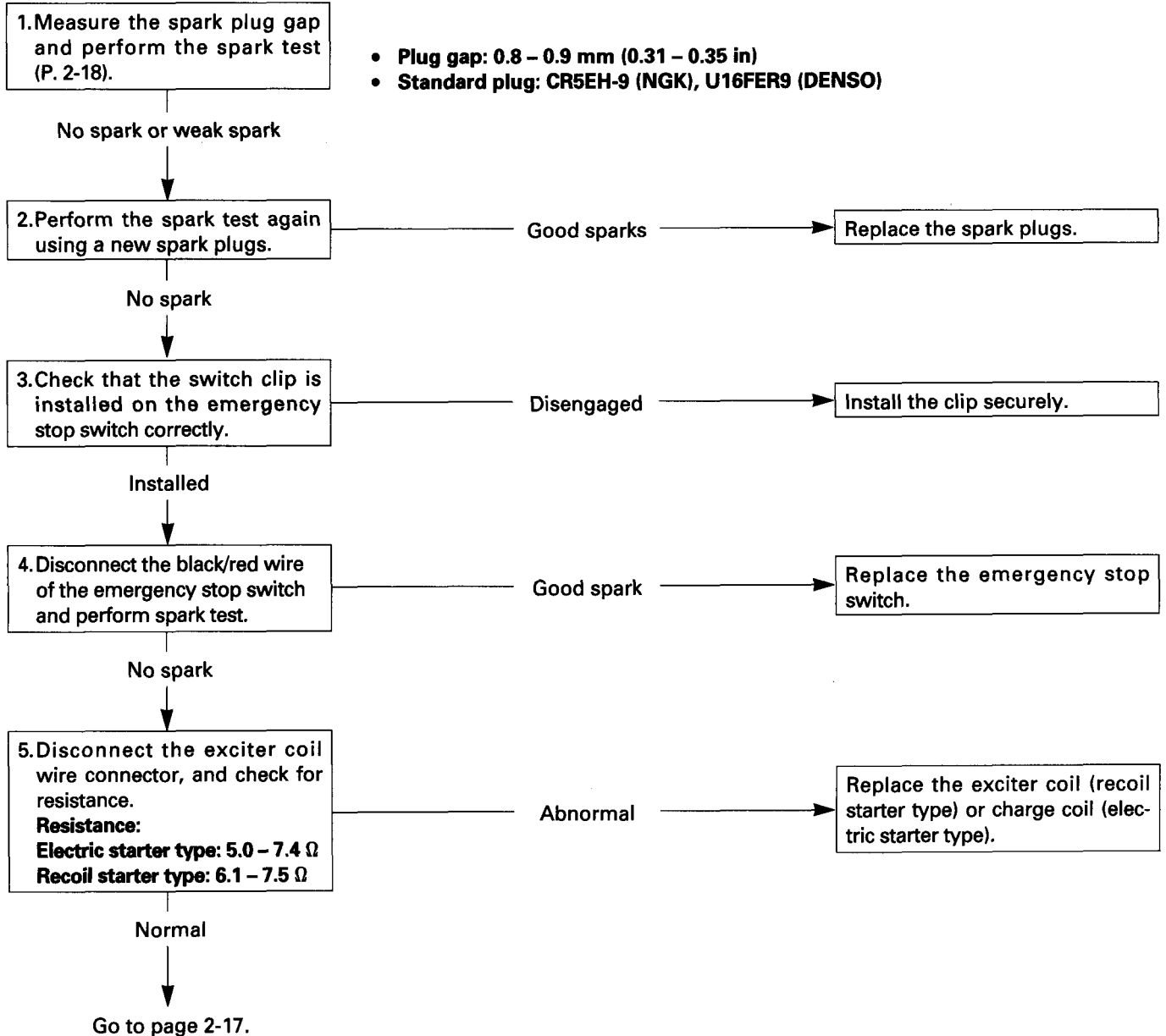

From page 2-16.

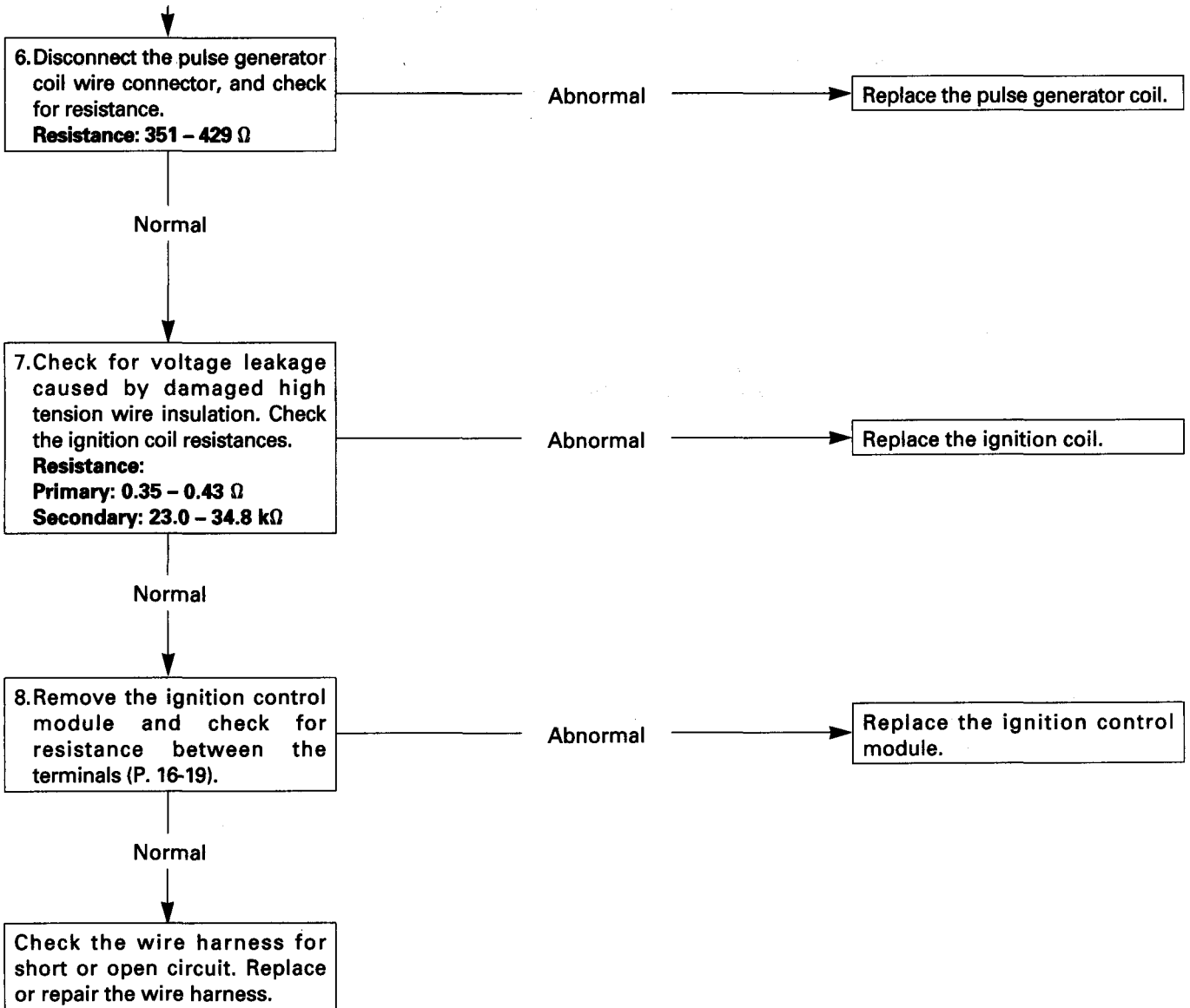

SPARK TEST

- 1) Remove the engine cover. Drain the gasoline from the carburetor.

▲ WARNING

Gasoline is highly flammable and explosive. If ignited, gasoline can burn you severely.

- **Be sure there is no spilled fuel near the engine.**
- **Place the spark plug away from the spark plug hole. Unburned gas can ignite if it is left in the cylinder.**
- **Loosen the carburetor drain screw to drain the carburetor thoroughly. Pull the recoil starter several times to release the unburned gas from the cylinder before testing the spark plug.**

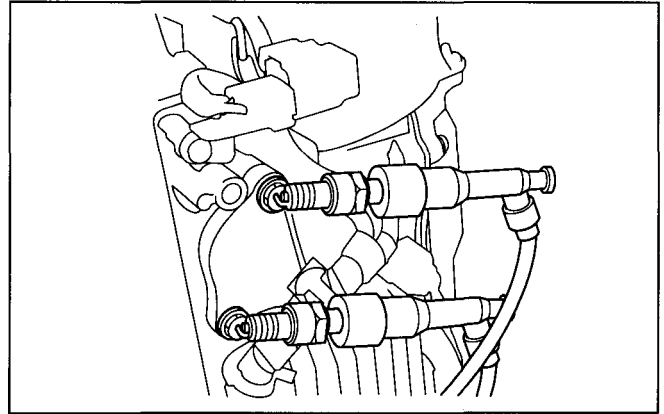

- 2) Remove the spark plug caps and spark plugs.
- 3) Pull the recoil starter several times to release the unburned gas from the cylinders.
- 4) Attach the removed spark plugs to the plug caps.
- 5) Set the ignition switch to the "ON" position (Remote control type only) and make sure that the emergency stop switch clip is engaged properly. Ground the negative (-) electrode (i.e. threaded part) of each spark plug against the thermostat cover bolt and pull the recoil starter rope to check whether sparks jump across the electrodes.
- 6) Remove the spark plugs from the spark plug caps and install the spark plugs to the other cylinder spark plug cap and check spark for the other cylinder.

• Engine Does Not Stop With The Ignition Switch Turned to OFF Position or Emergency Stop Switch Actuated.

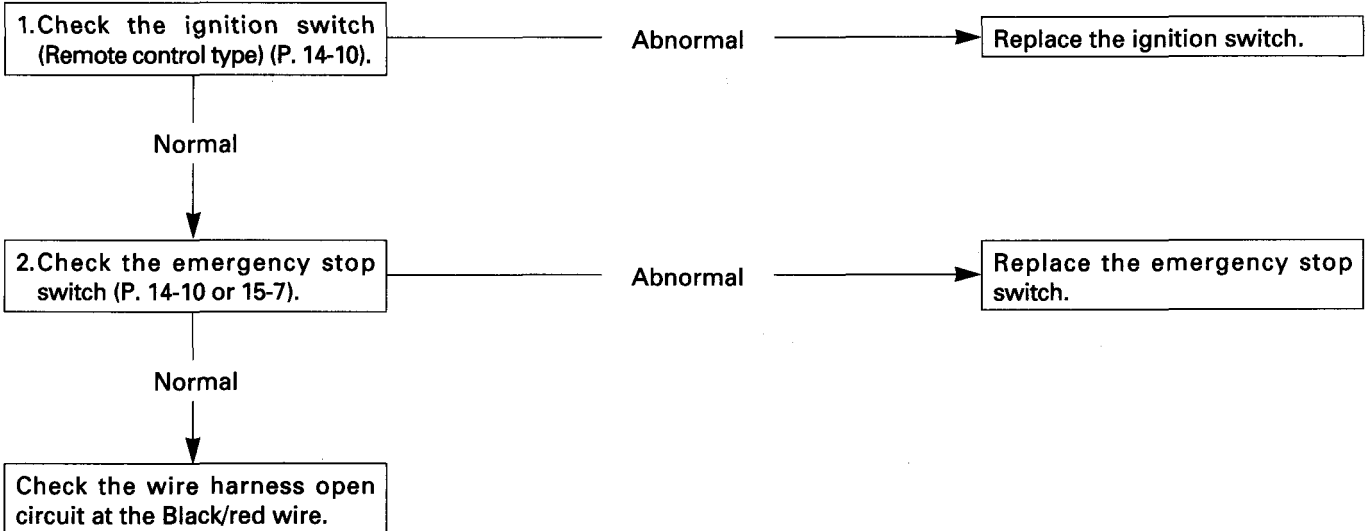

c. ELECTRIC STARTER SYSTEM

• Starter Motor Will Not Turn

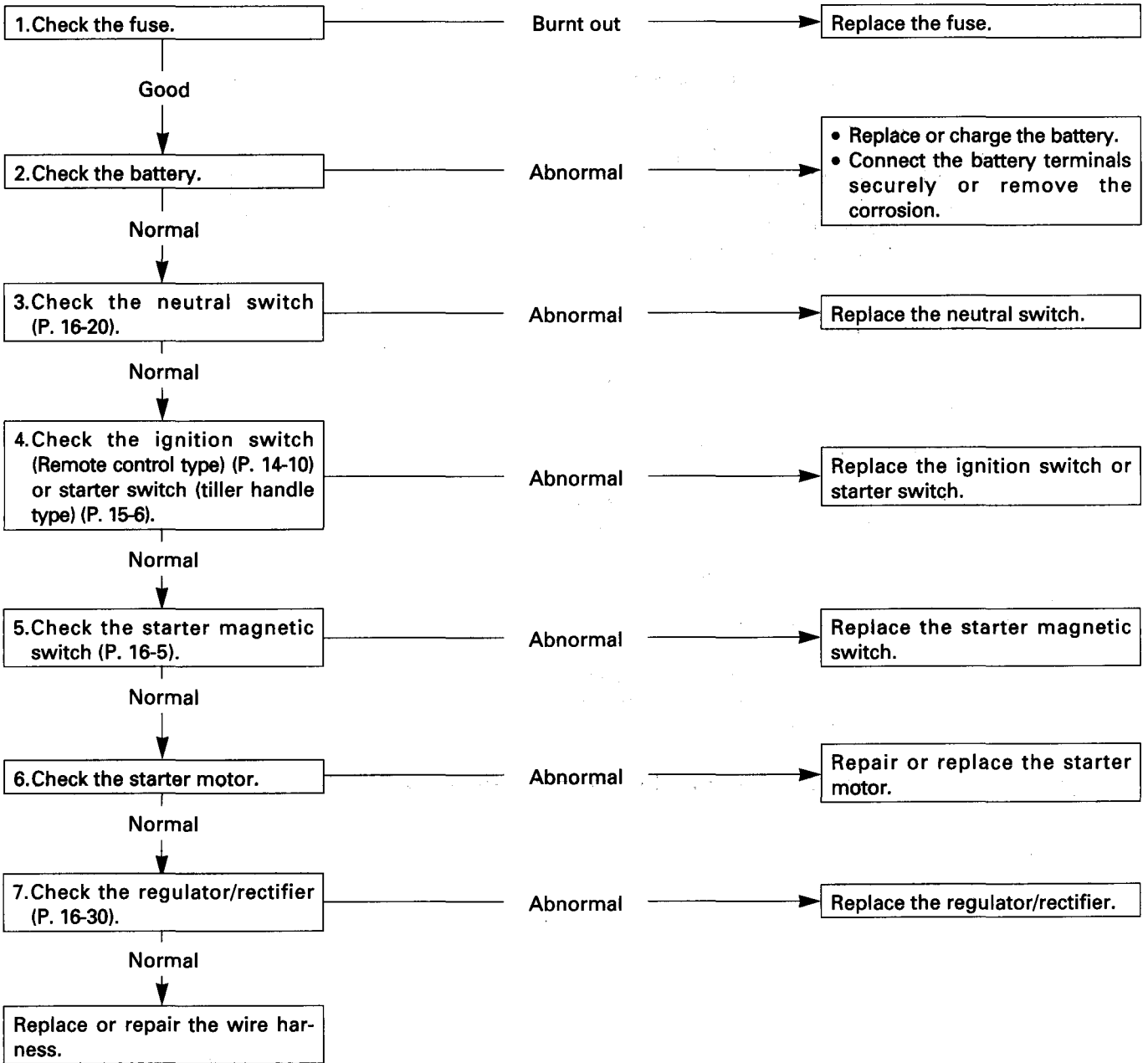

• Starter Motor Turns but Engine Does Not Turn.



• Starter Motor and Engine Turn Slowly.

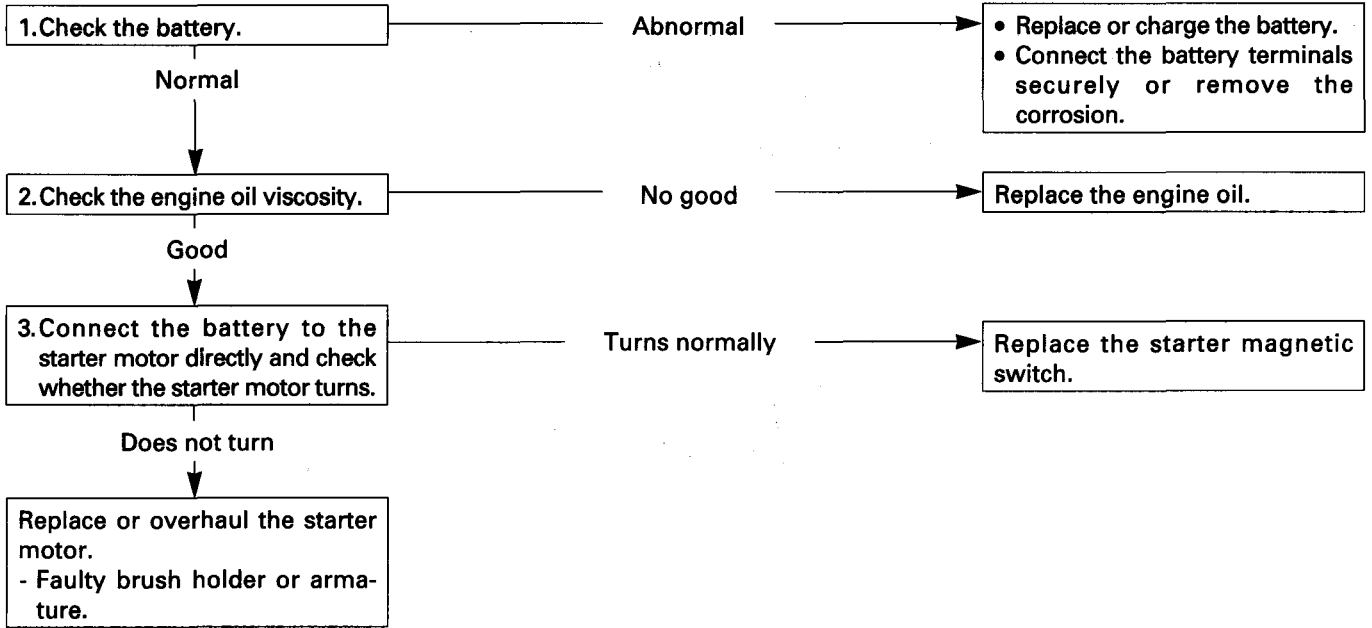

d. CHARGING SYSTEM

• Battery Under Charged

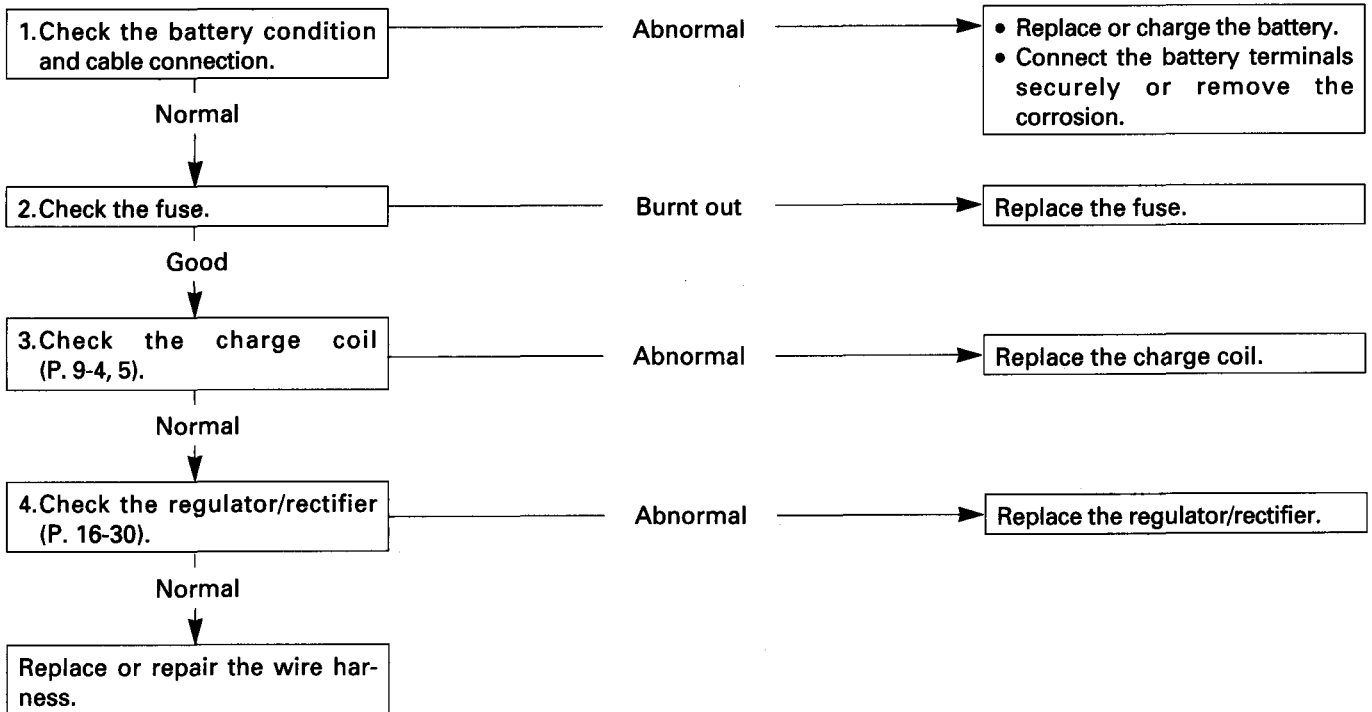

e. ALERT SYSTEM

These outboard motors are equipped with an alert system which protects the engine by controlling the engine speed in the ignition control module. When trouble occurs, the system slows down the engine speed gradually. The system is provided with indicator light and buzzer sound (remote control type only) to indicate the cause of trouble.

• Warning Buzzer Sounds (Remote Control Type)

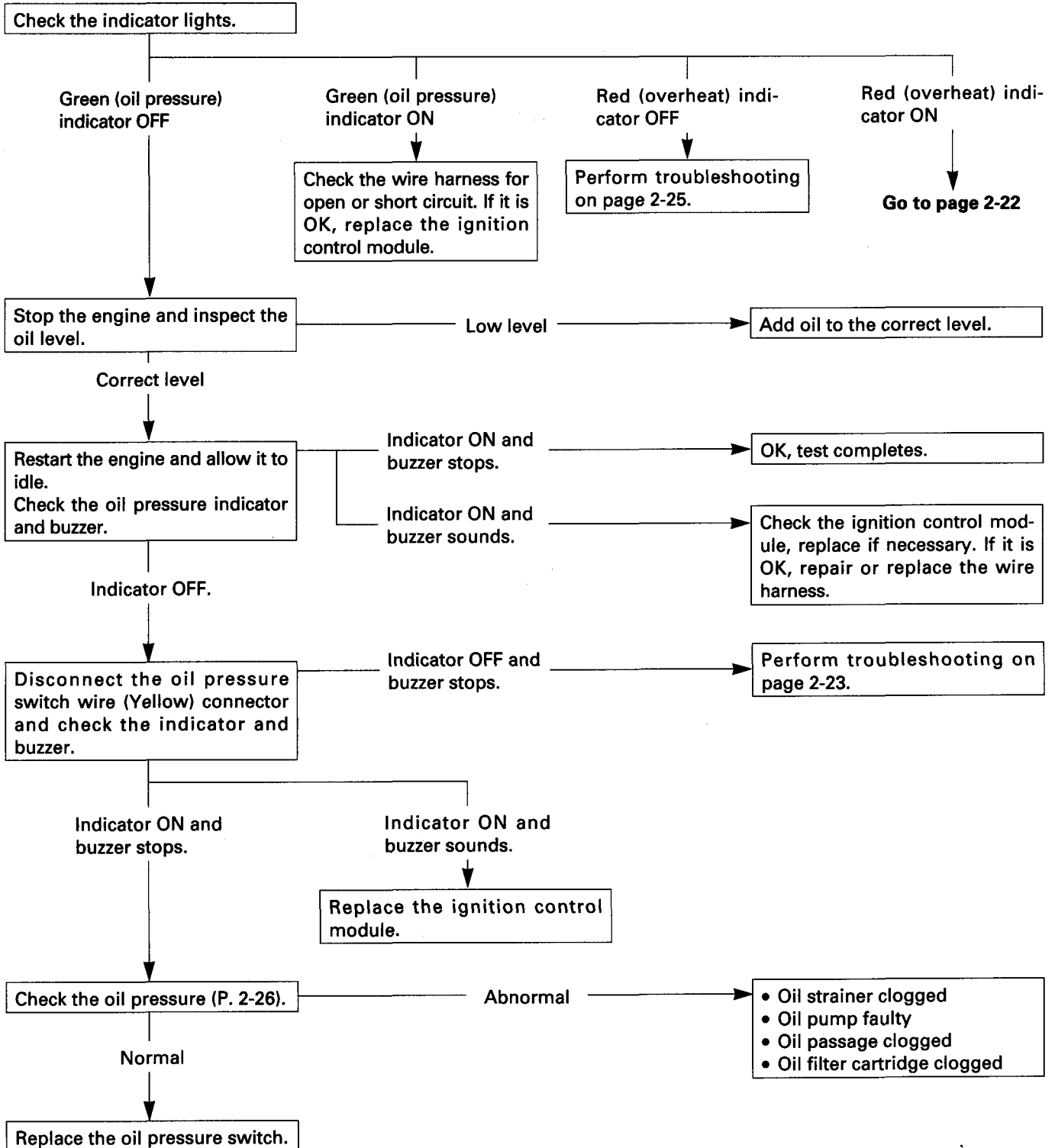

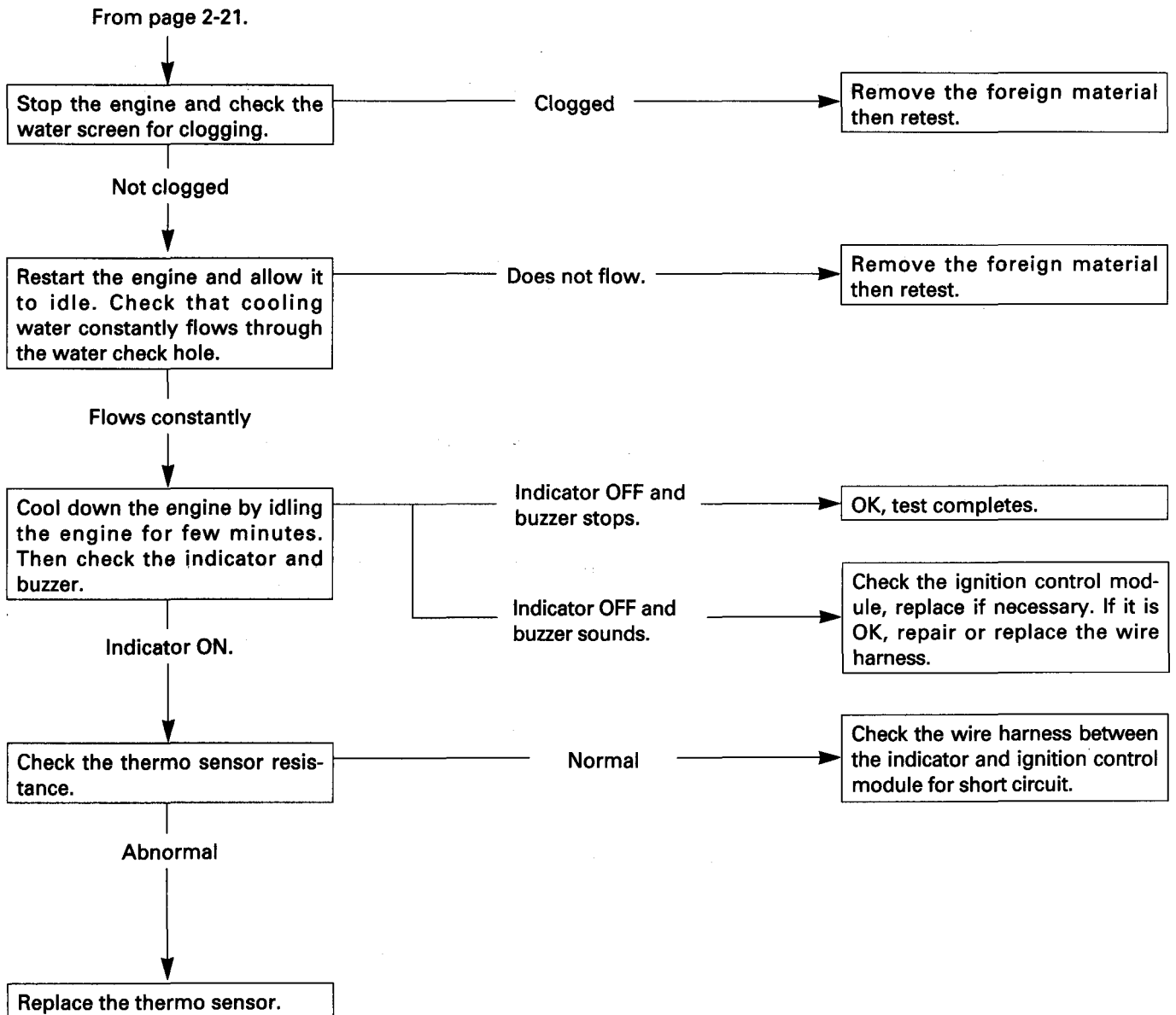

• Oil Pressure Indicator (Green) Test
 REMOTE CONTROL TYPE

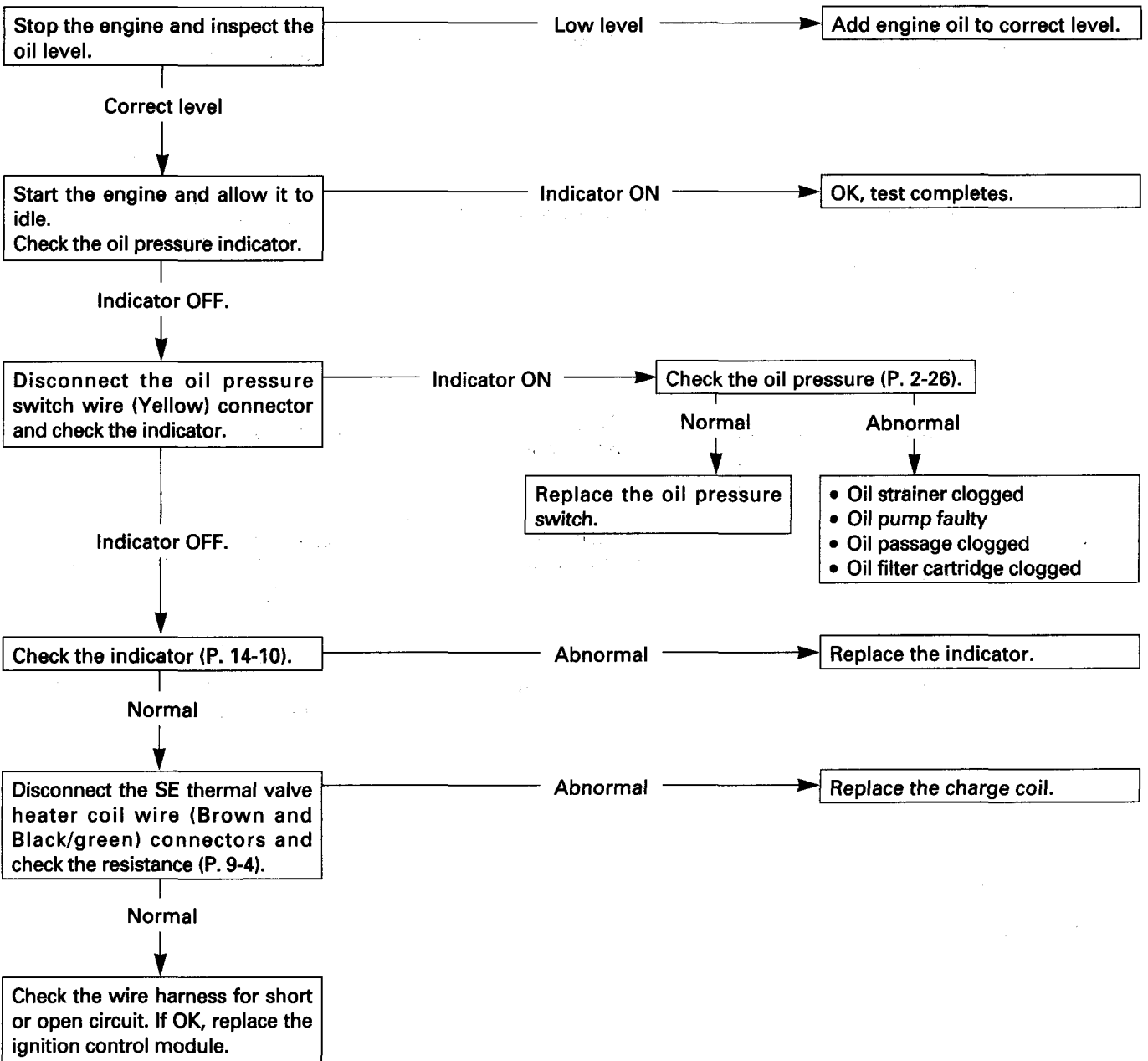



Download the full PDF manual instantly.

Our customer service e-mail:

aservicemanualpdf@yahoo.com