

## PREFACE

This manual covers the construction, function and servicing procedures of the Honda BF20A/BF25A outboard motors.

Careful observance of these instructions will result in better, safer service work.

Illustrations in this manual are based primarily on the BF25A LRS.

ALL INFORMATION, ILLUSTRATIONS, DIRECTIONS AND SPECIFICATIONS INCLUDED IN THIS PUBLICATION ARE BASED ON THE LATEST PRODUCT INFORMATION AVAILABLE AT THE TIME OF APPROVAL FOR PRINTING. HONDA MOTOR CO., LTD. RESERVES THE RIGHT TO MAKE CHANGES WITHOUT INCURRING ANY OBLIGATION WHATEVER. NO PART OF THIS PUBLICATION MAY BE REPRODUCED WITHOUT WRITTEN PERMISSION.

**HONDA MOTOR CO., LTD.**  
**SERVICE PUBLICATIONS OFFICE**

## CONTENTS

<b>SPECIFICATIONS</b>	<b>1</b>
<b>SERVICE INFORMATION</b>	<b>2</b>
<b>MAINTENANCE</b>	<b>3</b>
<b>ENGINE COVER/THROTTLE/CHOKE</b>	<b>4</b>
<b>FUEL SYSTEM</b>	<b>5</b>
<b>FLYWHEEL/TIMING BELT</b>	<b>6</b>
<b>RECOIL STARTER (TILLER HANDLE TYPE ONLY)</b>	<b>7</b>
<b>ENGINE REMOVAL/INSTALLATION</b>	<b>8</b>
<b>WATER JACKET COVER/THERMOSTAT/ THERMO SWITCH</b>	<b>9</b>
<b>CYLINDER HEAD/VALVES/OIL PUMP</b>	<b>10</b>
<b>CRANKCASE/CYLINDER BLOCK/ CRANKSHAFT/PISTON</b>	<b>11</b>
<b>PROPELLER/GEAR CASE/ EXTENSION CASE</b>	<b>12</b>
<b>OIL PAN/ENGINE UNDER CASE/ SWIVEL CASE</b>	<b>13</b>
<b>STEERING LINK ARM/REMOTE CONTROL BOX (REMOTE CONTROL TYPE ONLY)</b>	<b>14</b>
<b>THROTTLE CABLE RACKET/SHIFT LEVER/ TILLER HANDLE (TILLER HANDLE TYPE ONLY)</b>	<b>15</b>
<b>ELECTRICAL EQUIPMENT</b>	<b>16</b>
<b>OPERATION</b>	<b>17</b>
<b>WIRING DIAGRAM</b>	<b>18</b>
<b>BF30 SUPPLEMENT</b>	

# HONDA OUTBOARD MOTOR BF20A · BF25A

# SHOP MANUAL NEWS

## PAGE 1 OF 2

### Power Equipment

News No.  
P/P-035

Issue Date  
September '94

## SOME PARTS OF CHANGES

Applicable information	Publication No.
BF20A · BF25A	66ZV700

## CHANGE LOCATIONS

### P.12-21

## 8. BACKLASH ADJUSTMENT

### • FORWARD GEAR

#### BEFORE MODIFICATION

- 3) Turn the vertical shaft right and left while pressing it down with approximately 5 kg (11.0 lb) of force and measure the backlash.

Standard	0.10 – 0.29 mm (0.004 – 0.011 in)
----------	-----------------------------------

- 4) If the backlash is too large, increase the forward gear shim thickness and recheck the backlash.  
If the backlash is too small, decrease the forward gear shim thickness and recheck the backlash.

### P.12-22

### • REVERSE GEAR

- 3) Turn the vertical shaft right and left while pressing it down with approximately 5 kg (11.0 lb) of force and measure the backlash.

Standard	0.10 – 0.39 mm (0.004 – 0.015 in)
----------	-----------------------------------

- 4) If the backlash is too large, increase the reverse gear shim thickness and recheck the backlash.  
If the backlash is too small, decrease the reverse gear shim thickness and recheck the backlash.

#### AFTER MODIFICATION

- 3) Turn the vertical shaft right and left while pressing it down with approximately 5 kg (11.0 lb) of force and measure the backlash.

$$\text{Backlash} = \text{Dial Gauges measures} \times \frac{17.43^{*1}}{23^{*2}}$$

\*1 The pinion gear radius of pitch circle

\*2 The special tools (07MGJ-0010100) lever-length

Standard	0.10 – 0.29 mm (0.004 – 0.011 in)
----------	-----------------------------------

- 4) If the backlash is too large, increase the forward gear shim thickness and recheck the backlash.  
If the backlash is too small, decrease the forward gear shim thickness and recheck the backlash.

Service limit	0.30 mm (0.012 in)
---------------	--------------------

- 3) Turn the vertical shaft right and left while pressing it down with approximately 5 kg (11.0 lb) of force and measure the backlash.

$$\text{Backlash} = \text{Dial Gauges measures} \times \frac{17.43}{23}$$

Standard	0.10 – 0.39 mm (0.004 – 0.015 in)
----------	-----------------------------------

- 4) If the backlash is too large, increase the reverse gear shim thickness and recheck the backlash.  
If the backlash is too small, decrease the reverse gear shim thickness and recheck the backlash.

Service limit	0.40 mm (0.016 in)
---------------	--------------------

# HONDA OUTBOARD MOTOR BF20A · BF25A

# SHOP MANUAL NEWS

Power Equipment

News No.  
P/P-032

Issue Date  
August '94

## SOME PARTS OF CHANGES

Applicable information	Publication No.
BF20A · BF25A	66ZV700

## CHANGE LOCATIONS

The part numbers of the pin driver, 4mm and the special tool illustrations have been corrected as follows.

- Pin driver , 4mm

### BEFORE MODIFICATION

07944-9350200



### AFTER MODIFICATION

07744-0010300  
or 07944-SA00000

- Special tool illustrations

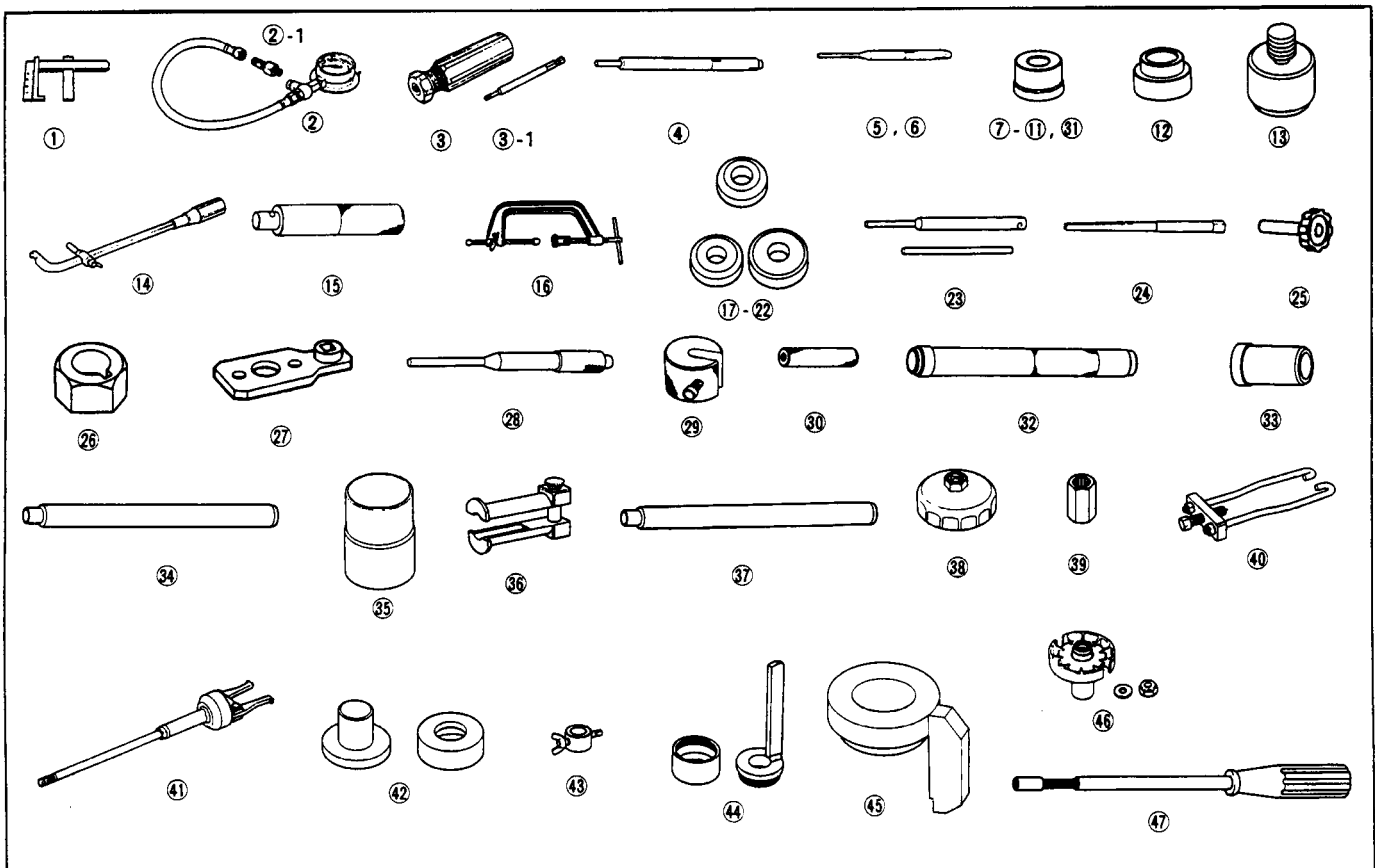

1. SPECIFICATIONS	2. DIMENSIONAL DRAWINGS
-------------------	-------------------------

## 1. SPECIFICATIONS

### DIMENSIONS AND WEIGHTS

Item	Model		BF20A					
	Description code		BAHS	BAHL	BAHS	BAHL	BAHS	BAHL
	Type		SH	LH	SHS	LHS	SRS	LRS
Overall length			*1: 675 mm (26.6 in) *2: 1,005 mm (39.6 in)				640 mm (25.2 in)	
Overall width			380 mm (15.0 in)				375 mm (14.8 in)	
Overall height			1,190 mm (46.9 in)	1,315 mm (51.8 in)	1,190 mm (46.9 in)	1,315 mm (51.8 in)	1,190 mm (46.9 in)	1,315 mm (51.8 in)
Dry weight			67 kg (147.7 lb)	69 kg (152.1 lb)	70 kg (154.3 lb)	72 kg (158.8 lb)	69 kg (152.1 lb)	71 kg (156.6 lb)
Operating weight (incl. oil)			69 kg (152.1 lb)	71 kg (156.6 lb)	72 kg (158.8 lb)	74 kg (163.2 lb)	71 kg (156.6 lb)	73 kg (161.0 lb)

\*1: With Tiller Handle raised

\*2: With Tiller Handle extended

### DIMENSIONS AND WEIGHTS

Item	Model		BF25A					
	Description code		BAJS	BAJL	BAJS	BAJL	BAJS	BAJL
	Type		SH	LH	SHS	LHS	SRS	LRS
Overall length			*1: 675 mm (26.6 in) *2: 1,005 mm (39.6 in)				640 mm (25.2 in)	
Overall width			380 mm (15.0 in)				375 mm (14.8 in)	
Overall height			1,190 mm (46.9 in)	1,315 mm (51.8 in)	1,190 mm (46.9 in)	1,315 mm (51.8 in)	1,190 mm (46.9 in)	1,315 mm (51.8 in)
Dry weight			67 kg (147.7 lb)	69 kg (152.1 lb)	70 kg (154.3 lb)	72 kg (158.8 lb)	69 kg (152.1 lb)	71 kg (156.6 lb)
Operating weight (incl. oil)			69 kg (152.1 lb)	71 kg (156.6 lb)	72 kg (158.8 lb)	74 kg (163.2 lb)	71 kg (156.6 lb)	73 kg (161.0 lb)

\*1: With Tiller Handle raised

\*2: With Tiller Handle extended

**FRAME**

Model		BF20A/BF25A					
Item	Type	SH	LH	SHS	LHS	SRS	LRS
Transom height		431 mm (17.0 in)	552 mm (21.7 in)	431 mm (17.0 in)	552 mm (21.7 in)	431 mm (17.0 in)	552 mm (21.7 in)
Transom angle		5 stage adjustment (4°, 8°, 12°, 16°, 20°)					
Tilting angle		75°					
Swivel angle		40° right and left					

**TYPES OF HONDA BF20A/BF25A OUTBOARD MOTORS**

It may be necessary to refer to this chart for reference purposes when reading this manual.

Models	Types	Shaft Length		Tiller Handle	Remote Control	Electric Starter	Recoil Starter
		Short	Long				
BF20A/BF25A	SH	●		●			●
	LH		●	●			●
	SHS	●		●		●	●
	LHS		●	●		●	●
	SRS	●			●	●	●
	LRS			●		●	●

S: Short Shaft    L: Long Shaft    H: Tiller Handle    R: Remote Control

**ENGINE**

Model	BF20A	BF25A
Type	4-stroke, O.H.C, 3-cylinder	
Displacement	499 cm <sup>3</sup> (30.5 cu in)	
Bore x stroke	58 x 63 mm (2.3 x 2.5 in)	
Rated power *1	20 HP (14.9 kw)/4,500—5,500 min <sup>-1</sup> (rpm)	25 HP (18.7 kw)/5,000—6,000 min <sup>-1</sup> (rpm)
Maximum torque	3.55 kg-m (25.7 ft-lb)/3,000 min <sup>-1</sup> (rpm)	3.59 kg-m (26.0 ft-lb)/4,000 min <sup>-1</sup> (rpm)
Compression ratio	9.2 : 1	
Fuel consumption ratio	214 g/PSH (7.5 oz/PSH)	239 g/PSH (8.4 oz/PSH)
Cooling system	Forced water circulation by impeller pump with thermostat	
Ignition system	CDI	
Ignition timing	5—26° B.T.D.C.	
Spark plug	DR7EA (NGK), X22ESR-U (NIPPONDENSO)	
Carburetor	Horizontal type, butterfly valve (3 carburetor)	
Lubrication system	Pressure lubrication by trochoid pump	
Lubrication capacity	1.9ℓ (2.00 US qt, 1.67 Imp qt)	
Starter system	Electric starter or Recoil starter	
Stopping system	Grounding of primary circuit	
Fuel	Regular automotive gasoline (86 pump octane; unleaded preferred)	
Fuel tank capacity	25 ℓ (6.6 US gal, 5.5 Imp gal)	
Fuel pump	Mechanical plunger type	
Exhaust system	Under water type	
Recommended oil	SAE 10W-30	

\*1: Full throttle range.

**LOWER UNIT**

Clutch	Dog clutch (Forward—Neutral—Reverse)
Gear ratio	0.48 (13/27)
Reduction	Spiral bevel
Gear case oil capacity	0.29 ℓ(0.307 US qt, 0.255 Imp qt)
Propeller No. of blades-Dia. x Pitch	3-235 x 305 mm (9-1/4 x 12.0 in)
Propeller rotating direction	Clockwise (viewed from rear)
Propeller driving system	Spline

## 2. DIMENSIONAL DRAWINGS

Unit: mm (in)

Remote control type  
[ ]: Short shaft type

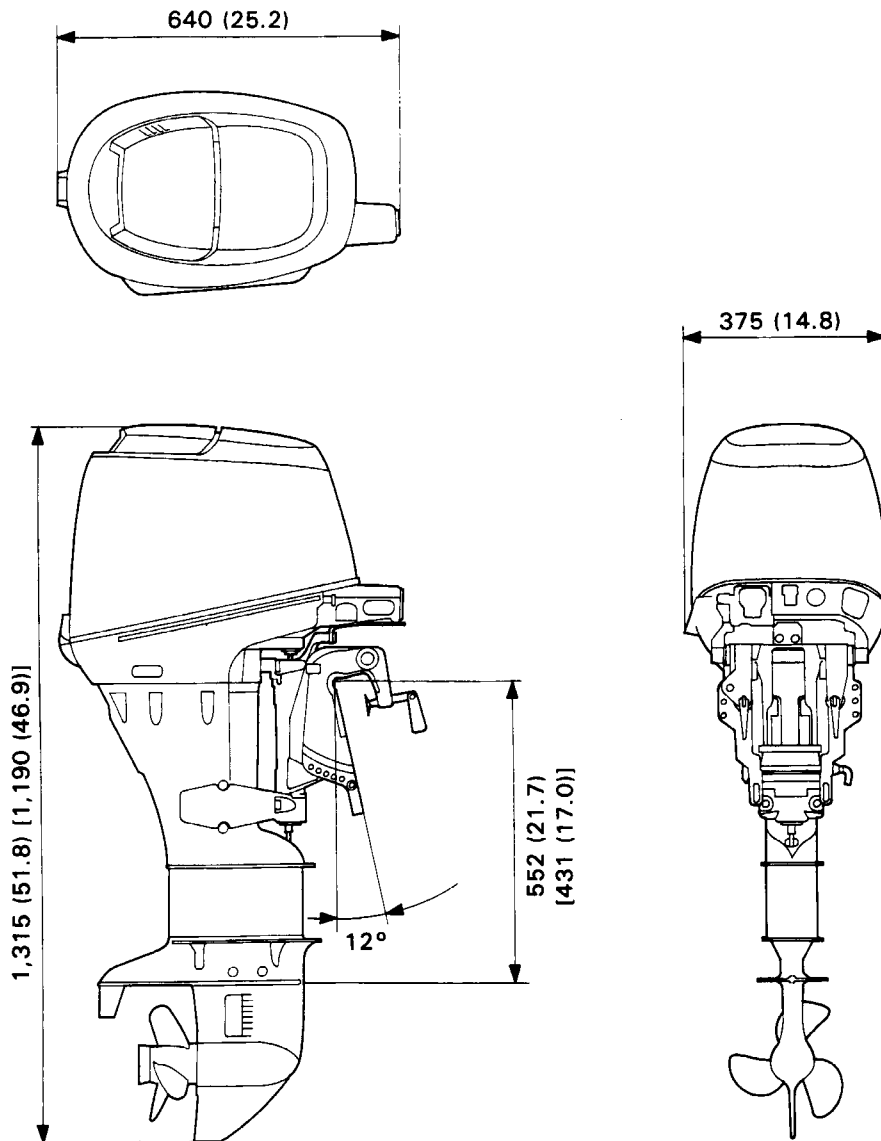

Tiller handle type  
 [ ]: Short shaft type

Unit: mm (in)

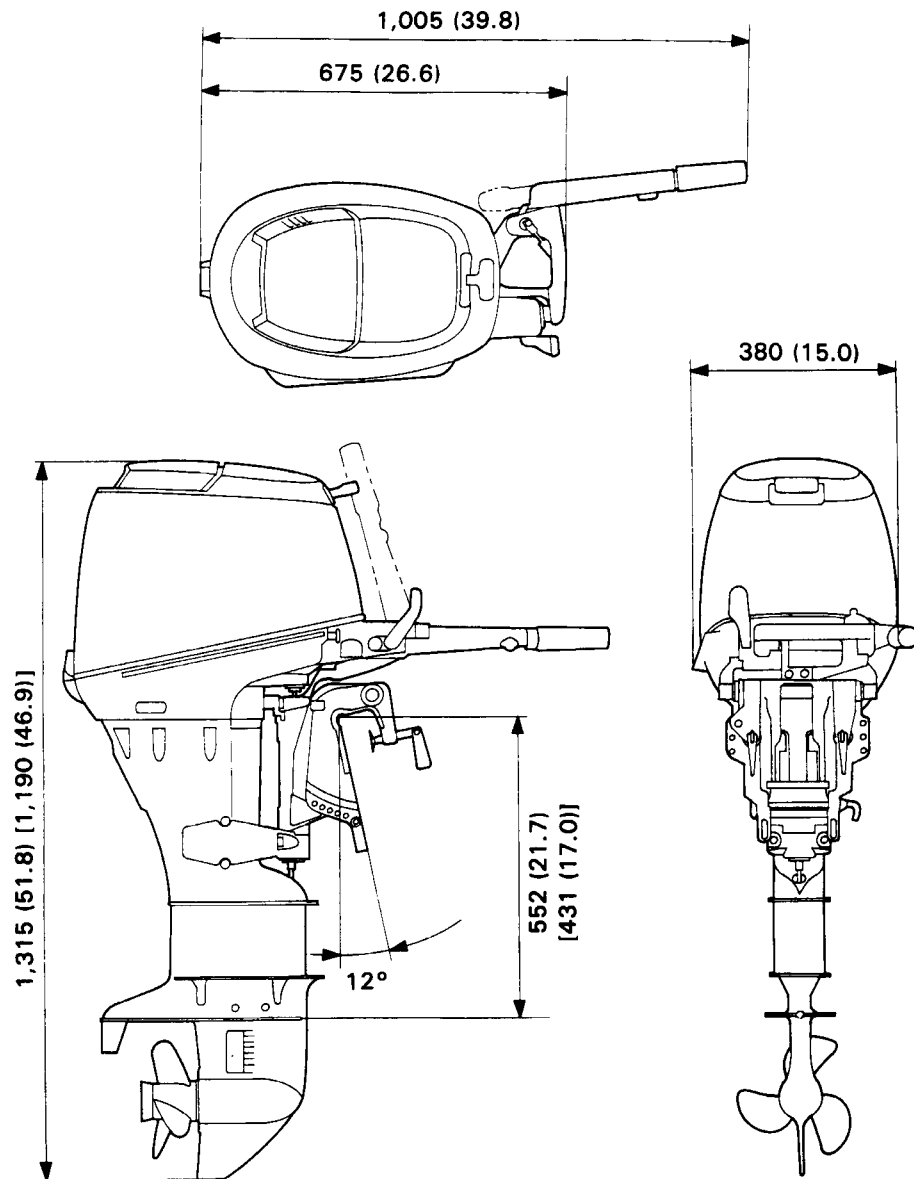

### PROPELLER SHAFT

Unit: mm (in)

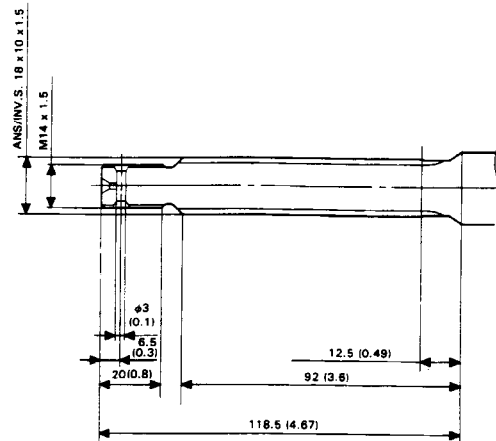



- |   |   |
|---|---|
| <ol style="list-style-type: none"> <li>1. GENERAL SAFETY</li> <li>2. SERVICE RULES</li> <li>3. SERIAL NUMBER LOCATION</li> <li>4. MAINTENANCE STANDARDS</li> <li>5. TORQUE VALUES</li> <li>6. SPECIAL TOOLS</li> <li>7. TROUBLESHOOTING             <ol style="list-style-type: none"> <li>A. HARD STARTING<br/>Cylinder Compression Test</li> <li>B. IGNITION SYSTEM<br/>Spark Test</li> </ol> </li> </ol> | <ol style="list-style-type: none"> <li>C. ELECTRIC STARTER<br/>(Electric starter type only)</li> <li>D. ENGINE DOES NOT RUN SMOOTHLY</li> <li>E. ALERT SYSTEMS<br/>Oil Pressure Test</li> <li>F. SHIFT LEVER</li> <li>8. CABLE/HARNESS ROUTING</li> <li>9. TUBE ROUTING</li> <li>10. LUBRICATION</li> <li>11. MAINTENANCE SCHEDULE</li> </ol> |
|---|---|

## 1. GENERAL SAFETY

Pay attention to these symbols and their meanings:

- ⚠ WARNING** Indicates a strong possibility of severe personal injury or death if instructions are not followed.  
**CAUTION:** Indicates a possibility of personal injury or equipment damage if instructions are not followed.

**⚠ WARNING**

- Stop the engine, and remove the spark plug caps and ignition key before servicing the outboard motor.
- If the motor must be running to do some work, make sure the area is well ventilated. Never run the engine in a closed area; the exhaust contains poisonous carbon monoxide gas.
- Gasoline is extremely flammable and is explosive under certain conditions. Do not smoke or allow flames or sparks in your working area.

**CAUTION**

- Keep away from rotating or hot parts and high voltage wires when the engine is run with the engine cover off.

## 2. SERVICE RULES

1. Use genuine Honda or Honda-recommended parts and lubricants or their equivalents. Parts that do not meet Honda's design specifications may damage the unit.
2. Use the special tools designed for the product.
3. Install new gaskets, O-rings, etc. when reassembling.
4. When torquing bolts or nuts, begin with larger-diameter or inner bolts first and tighten to the specified torque diagonally, unless a particular sequence is specified.
5. Clean parts in cleaning solvent upon disassembly. Lubricate any sliding surfaces before reassembly.
6. After reassembly, check all parts for proper installation and operation.
7. Many screws used in this machine are self-tapping. Be aware that cross-threading or overtightening these screws will strip the female threads and ruin the hole.
8. Use only metric tools when servicing this unit. Metric bolt, nuts and screws are not interchangeable with nonmetric fasteners. The use of incorrect tools and fasteners will damage the unit.
9. Follow the instructions represented by these symbols when they are used:



: Apply oil



: Use special tool



: Apply grease

○ x ○ (○) : Indicates the type, length, and number of the flange bolt used.

P : Indicates the reference page.



: Use molybdenum oil solution (mixture of the engine oil and molybdenum grease with the ratio 1 : 1).

( Molybdenum  
disulfide oil )

### 3. SERIAL NUMBER LOCATION

The engine serial number is stamped on the cylinder block and the produce identification number is located on the R. stem bracket. Always specify these numbers when inquiring about the engine or when ordering parts in order to obtain the correct parts for outboard motor being serviced.

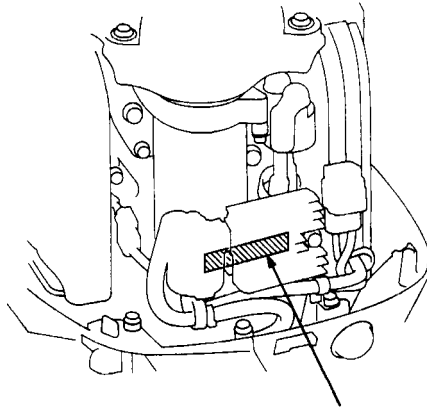

**ENGINE SERIAL NUMBER**

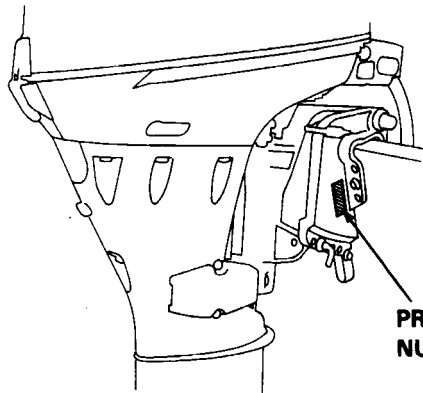

**PRODUCT IDENTIFICATION  
NUMBER**

## 4. MAINTENANCE STANDARDS

### ENGINE

Unit: mm (in)

Part	Item		Standard	Service limit
Engine	Idle speed (in neutral)		900 ± 50 min <sup>-1</sup> (rpm)	—
	Cylinder compression		15 ± 1 kg/cm <sup>2</sup> (212 ± 14 psi) at 500 min <sup>-1</sup> (rpm)	—
Carburetor	Main jet		# 100	—
	Pilot screw opening		2 turns out	—
	Float height		14 (0.6)	—
Spark plug	Gap		0.6–0.7 (0.024–0.028)	—
Valves	Valve clearance	IN	0.10–0.14 (0.004–0.006)	—
		EX	0.18–0.22 (0.007–0.009)	—
	Stem O.D.	IN	5.475–5.490 (0.2156–0.2161)	5.45 (0.215)
		EX	5.455–5.470 (0.2148–0.2154)	5.43 (0.214)
	Guide I.D.	IN/EX	5.500–5.512 (0.2165–0.2170)	5.54 (0.218)
	Seat width	IN	0.9–1.1 (0.035–0.043)	2.0 (0.08)
		EX	0.9–1.1 (0.035–0.043)	2.0 (0.08)
	Spring free length	IN/EX	36.8 (1.45)	35.3 (1.39)
	Stem-to-guide clearance	IN	0.010–0.037 (0.0004–0.0015)	0.07 (0.003)
EX		0.030–0.057 (0.0012–0.0022)	0.12 (0.005)	
Rocker arm	Rocker arm I.D.		13.000–13.018 (0.5118–0.5125)	13.04 (0.513)
	Rocker arm shaft O.D.		12.962–12.980 (0.5103–0.5110)	12.92 (0.509)
	Rocker arm shaft-to-rocker arm clearance		0.020–0.056 (0.0007–0.0022)	0.07 (0.003)
Piston	Skirt O.D.		57.970–57.990 (2.2823–2.2831)	57.92 (2.280)
	Piston-to-cylinder clearance		0.010–0.045 (0.0004–0.0018)	0.1 (0.004)
	Pin bore I.D.		14.002–14.008 (0.5513–0.5515)	14.02 (0.552)
	Pin O.D.		13.994–14.000 (0.5509–0.5512)	13.97 (0.550)
	Pin-to-pin bore clearance		0.002–0.014 (0.0001–0.0006)	0.04 (0.002)
Piston ring	Ring side clearance	Top	0.025–0.055 (0.0010–0.0022)	0.1 (0.004)
		Second	0.025–0.055 (0.0010–0.0022)	0.1 (0.004)
		Oil	0.055–0.14 (0.0022–0.006)	0.2 (0.008)
	Ring end gap	Top	0.15–0.3 (0.006–0.012)	0.5 (0.02)
		Second	0.35–0.50 (0.014–0.020)	0.7 (0.03)
		Oil	0.20–0.80 (0.008–0.031)	1.0 (0.04)
	Ring thickness	Top	1.175–1.190 (0.0463–0.0469)	1.08 (0.043)
Second		1.175–1.190 (0.0463–0.0469)	1.08 (0.043)	
Cylinder/ cylinder head	Cylinder sleeve I.D.		58.000–58.015 (2.2835–2.2841)	58.055 (2.2856)
	Distortion of cylinder head		0.05 (0.002)	0.1 (0.004)
	I.D. of camshaft journal (Oil pump journal)	# 1	20.000–20.021 (0.7874–0.7882)	20.05 (0.789)
		# 2	30.000–30.025 (1.1811–1.1821)	30.06 (1.183)
		# 3	18.000–18.027 (0.7087–0.7097)	18.06 (0.711)

Unit: mm (in)

Part	Item		Standard	Service limit
Connecting rod	Small end I.D.		14.010 – 14.022 (0.5516 – 0.5520)	14.05 (0.553)
	Big end oil clearance		0.010 – 0.028 (0.0004 – 0.0011)	0.4 (0.01)
	Big end axial clearance		0.12 – 0.27 (0.005 – 0.011)	0.4 (0.01)
	Connecting rod bearing oil clearance		0.018 – 0.042 (0.0007 – 0.0017)	0.8 (0.03)
Crankshaft	Journal O.D.	Main	35.986 – 36.002 (1.4168 – 1.4174)	35.96 (1.416)
		Pin	31.987 – 32.011 (1.2593 – 1.2603)	31.96 (1.258)
	Crankshaft main bearing oil clearance		0.020 – 0.044 (0.0008 – 0.0017)	0.06 (0.002)
	Crankshaft side clearance		0.05 – 0.30 (0.002 – 0.012)	0.45 (0.018)
Camshaft	Shaft axial clearance		0.15 – 0.40 (0.006 – 0.016)	0.6 (0.02)
	Shaft runout		0.03 (0.001) Max.	0.05 (0.002)
	Journal O.D.	# 1	19.959 – 19.980 (0.7858 – 0.7866)	19.93 (0.785)
		# 2	29.939 – 29.960 (1.1787 – 1.1795)	29.9 (1.18)
		# 3	17.966 – 17.984 (0.7073 – 0.7080)	17.94 (0.706)
	Cam height	IN	24.073 – 24.313 (0.9478 – 0.9572)	23.843 (0.9387)
		EX	24.105 – 24.345 (0.9490 – 0.9585)	23.905 (0.9411)
	Shaft oil clearance	# 1	0.020 – 0.062 (0.0008 – 0.0024)	0.08 (0.003)
		# 2	0.040 – 0.086 (0.0016 – 0.0034)	0.11 (0.004)
# 3		0.016 – 0.061 (0.0006 – 0.0024)	0.08 (0.003)	
Oil pump	Body I.D.		40.71 – 40.74 (1.603 – 1.604)	40.76 (1.605)
	Inner rotor-to-outer rotor clearance		0.15 (0.006) Max.	0.2 (0.01)
	Outer rotor-to-body clearance		0.15 – 0.21 (0.006 – 0.008)	0.26 (0.010)
	Outer rotor height		14.98 – 15.00 (0.590 – 0.591)	14.96 (0.589)
	Pump body depth		15.02 – 15.05 (0.591 – 0.593)	15.09 (0.594)
	Pump end clearance		0.02 – 0.07 (0.001 – 0.003)	0.1 (0.004)
Ignition coil	Resistance	Primary coil	0.19 – 0.23 $\Omega$	—
		Secondary coil	10.3 – 15.9 k $\Omega$	—
Exciter coil	Resistance		272 – 368 $\Omega$	—
Pulser coil	Resistance		290 – 355 $\Omega$	—

**FRAME**

Unit: mm (in)

Part	Item		Standard	Service limit
Vertical shaft	Shaft O.D. (at needle bearing)		22.217–22.230 (0.8747–0.8752)	22.196 (0.8739)
Bevel gear	Gear I.D.	Forward	19.000–19.021 (0.7480–0.7489)	19.04 (0.750)
		Reverse	22.05–22.30 (0.868–0.878)	22.35 (0.880)
Propeller shaft	Shaft O.D.	Front	18.967–18.980 (0.7467–0.7472)	18.946 (0.7459)
		Rear	20.9–21.2 (0.82–0.83)	20.85 (0.821)
	Shaft O.D. (at needle bearing)		22.007–22.020 (0.8664–0.8669)	21.99 (0.866)

## 5. TORQUE VALUES

Item	Thread Dia. (mm) and pitch (length)	Torque values		
		N·m	kg·m	ft·lb
• ENGINE				
Crankcase bolt	*1 M8 x 1.25	29	2.9	21.0
	M6 x 1.0	12	1.2	8.7
Oil filter cartridge	M20 x 1.5	11	1.1	8.0
Water jacket cover bolt	M6 x 1.0	12	1.2	8.7
Thermostat cover bolt	M6 x 1.0	12	1.2	8.7
Cylinder head bolt	*1 M8 x 1.25	29	2.9	21.0
	M8 x 1.25	27	2.7	19.5
Cylinder head cover bolt	M6 x 1.0	12	1.2	8.7
Fuel pump bolt	M6 x 1.0	10	1.0	7.2
Throttle cam	M6 x 1.0	12	1.2	8.7
Choke arm bolt	M6 x 1.0	12	1.2	8.7
Intake manifold bolt, nut	M6 x 1.0	12	1.2	8.7
Carburetor bolt	M6 x 1.0	10	1.0	7.2
Connecting rod nut	M7 x 0.75	24	2.4	17.4
Valve adjusting nut	M5 x 0.5	8	0.8	5.8
Oil drain bolt	M12 x 1.5	23	2.3	16.6
Exhaust pipe bolt	M6 x 1.0	10	1.0	7.2
Oil pan bolt	M6 x 1.0	10	1.0	7.2
Oil pump bolt	M6 x 1.0	13	1.3	9.4
Oil strainer bolt	M6 x 1.0	13	1.3	9.4
Timing pulley nut	M34 x 1.0	65	6.5	47.0
Timing belt tensioner bolt	M10 x 1.25	44	4.4	31.8
Timing belt adjusting spring bolt	M6 x 1.0	12	1.2	8.7
Flywheel nut	M16 x 1.5	115	11.5	83.2
Cam pulley bolt	M8 x 1.25	27	2.7	19.5
Oil pressure switch	PT 1/8	9	0.9	6.5
Thermo switch	M16 x 1.5	12	1.2	8.7
Starter solenoid cable				
(starter solenoid side)	M6 x 1.0	5	0.5	3.6
(electric starter side)	M8 x 1.25	27	2.7	19.5
CDI unit bolt	M6 x 1.0	5	0.5	3.6
Choke solenoid bracket bolt				
(Remote control type only)	M6 x 1.0	9	0.9	6.5

\*1: Tighten the crankcase bolts to 29 N·m (2.9 kg·m, 21.0 ft·lb) and the cylinder head bolts to 29 N·m (2.9 kg·m, 21.0 ft·lb) first, then tighten them an additional  $90^{\circ} +_{0}^{30}$ .

Item	Thread Dia. (mm) and pitch (length)	Torque values		
		N·m	kg-m	ft-lb
<b>•GEAR CASE</b>				
Pinion gear nut	M10×1.0	40	4.0	28.9
Gear case bolt	M10×1.25	35	3.5	25.3
Oil check plug	M8 × 1.25	3.5	0.35	2.5
Oil drain plug	M8 × 1.25	3.5	0.35	2.5
Wash plug	M8 × 1.25	3.5	0.35	2.5
Impeller housing bolt	M6 × 1.0	11	1.1	8.0
Propeller shaft castle nut	M14×1.5	1	0.1	0.7
<b>•EXTENSION/MOUNT</b>				
Extension case bolt	M8 × 1.25	22	2.2	15.9
Lower rubber motor mount nut	M12×1.25	55	5.5	39.8
Lower motor mount housing nut	M8 × 1.25	22	2.2	15.9
Upper rubber motor mount nut	M10×1.25	45	4.5	32.5
<b>•STERN BRACKET</b>				
Stern bracket nut (L.side)	7/8-14 UNF	17.5	1.75	12.7
(R.side)	7/8-14 UNF	32.5	3.25	23.5
	M8 x 1.25	22	2.2	15.9
<b>•FRAME/ELECTRICAL</b>				
Emergency stop switch nut	M16×1.0	1.5	0.15	1.1
Starter button nut (tiller handle type only)	M16×1.0	1.5	0.15	1.1
Water hose joint	PT1/8	9	0.9	6.5
Sampling probe cap (Bodensee type only)	M14 x 1.25	5	0.5	3.6
Sampling probe pipe (Bodensee type only)	M14 x 1.25	20	2.0	14.5

\* 1: First, tighten to the specified torque. If the cotter pin does not set in the hole, tighten additionally until the cotter pin sets in the hole securely.

Specified torque: 1 N·m (0.1 kg-m, 0.7 ft-lb)

Maximum torque: 35 N·m (3.5 kg-m, 25.3 ft-lb)

NOTE: Use standard torque values for fasteners that are not listed in this table.

### STANDARD TORQUE VALUES

Item	Thread Dia.	Torque values		
		N·m	kg-m	ft-lb
Bolt and nut	5 mm	5	0.5	3.6
	6 mm	10	1.0	7.2
	8 mm	21	2.1	15.2
	10 mm	35	3.5	25.3
	12 mm	55	5.5	39.8
Flange bolt and nut	6 mm (SH Flange bolt)	9	0.9	6.5
	6 mm	12	1.2	8.7
	8 mm	27	2.7	19.5
	10 mm	35	3.5	25.3
	12 mm	60	6.0	43.4
Screw	5 mm	4	0.4	2.9
	6 mm	9	0.9	6.5

## 6. SPECIAL TOOLS

Tool name	Tool number	Application
1. Float level gauge	07401-0010000	Inspection for carburetor float level
2. Oil pressure gauge	07506-3000000	Inspection for oil pressure
2-1. -attachment	07406-0030000	
3. Torx bit handle	07703-0010300	Handle for 3-1
3-1. -screw T20H	07703-0010400	Fuel pump disassembly/reassembly
4. Valve guide driver, 5.5 mm	07742-0010100	Valve guide removal/installation
5. Pin driver, 2.5 mm	07744-0010100	2.5 x 22 mm, 2.5 x 25 mm spring pin, 25 x 13.8 mm roller removal/installation
6. Pin driver, 3.0 mm	07744-0010200	3 x 20 mm, 3 x 25 mm spring pin removal/installation
7. Attachment, 32 x 35 mm	07746-0010100	22 x 35 x 7 mm water seal, lower motor mount center housing installation
8. Attachment, 37 x 40 mm	07746-0010200	Gear case inner race installation
9. Attachment, 42 x 47 mm	07746-0010300	Vertical shaft outer race installation
10. Attachment, 62 x 68 mm	07746-0010500	Gear case outer race installation
11. Attachment, 24 x 26 mm	07746-0010700	7/8 x 1-1/8 x 1 mm needle bearing installation, reverse gear removal/installation, 17 x 26 x 7 mm water seal installation
12. Attachment, 35 mm I.D.	07746-0030400	32 x 58 x 13 mm bearing, gear case inner race installation
13. Pilot, 22 mm	07746-0041000	7/8 x 1-1/8 x 1 mm removal/installation, 22 x 28 x 20 mm needle bearing installation
14. Oil seal driver	07748-0010001	Oil seal, water seal removal
15. Driver	07749-0010000	Driver for 7, 8, 9, 10, 11 and 31
16. Valve spring compressor	07757-0010000	Valve keeper removal/installation
17. Valve seat cutter, 45° φ24.5	07780-0010100	Valve seat reconditioning EX
18. Valve seat cutter, 45° φ29	07780-0010300	Valve seat reconditioning IN
19. Valve seat cutter, 32° φ25	07780-0012000	Valve seat reconditioning EX
20. Valve seat cutter, 32° φ28	07780-0012100	Valve seat reconditioning IN
21. Valve seat cutter, 60° φ30	07780-0014000	Valve seat reconditioning IN
22. Valve seat cutter, 60° φ26	07780-0014500	Valve seat reconditioning EX
23. Cutter holder, 5.5 mm	07781-0010101	Valve seat reconditioning
24. Valve guide reamer	07984-2000001	Valve guide reaming
25. Valve adjusting screw	07908-KE90000	Valve clearance adjustment
26. Crankshaft holder	07923-ZA00100	34 mm lock nut removal/installation
27. Holder	07926-VA20001	Flywheel removal/installation
28. Pin driver, 4 mm	07944-9350200	4 x 22 mm, 4 x 28 mm spring pin removal/installation
29. Remover weight	07741-0010201	Constituents of
30. Remover handle	07936-3710100	Bearing race puller (item 41).
31. Attachment, 28 x 30 mm	07946-1870100	22 x 28 x 20 mm needle bearing, 17 x 30 x 7 mm water seal installation
32. Stem race driver	07946-GC40000	Vertical shaft inner race installation
33. Driver head	07946-KM40701	22 x 28 x 20 mm needle bearing installation
34. Driver shaft	07946-MJ00100	22 x 28 x 20 mm needle bearing installation



Tool name	Tool number	Application
35. Support base	07965—SD90100	Reverse gear removal
36. Remover attachment, 22 mm I.D.	07GMD—KT70200	Reverse gear removal
37. Driver	07949—3710001	7/8 x 1-1/8 x 1 mm needle bearing removal/installation, gear case outer race installation, reverse gear removal
38. Oil filter wrench	07HAA—PJ70100	Oil filter replacing
39. Vertical shaft holder	07LPB—ZV30200	Vertical shaft lock nut removal/installation
40. Propeller shaft holder	07LPB—ZV30300	Forward gear backlash inspection
41. Bearing race puller	07LPC—ZV30100	Vertical shaft, gear case outer race, 32 x 58 x 13 mm bearing removal
42. Bearing height gauge	07LPJ—ZV30200	Forward gear shim adjustment
43. Backlash inspection attachment	07MGJ—0010100	Forward/reverse gear backlash inspection
44. Vertical shaft gauge	07PPJ—ZV70100	Vertical shaft shim adjustment
45. Propeller shaft gauge	07PPJ—ZV70200	Propeller shaft shim adjustment
46. Test propeller	07PPZ—ZV70100	For test operation in water tank
47. Pilot screw wrench	07KMA—MS60101	Pilot screw adjustment (Bodenss type only)

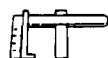

①

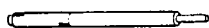

②



③-⑦、②⑧



⑧



⑨



⑩



⑪



⑫-⑮



⑯-⑱

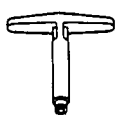

⑲



⑳



㉑

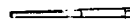

㉒



㉓



㉔



㉕、㉗



㉖



㉙



㉚

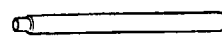

㉛



㉜

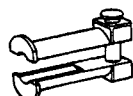

㉝



㉞



㉟



㊱

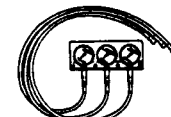

㊲



㊳

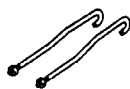

㊴

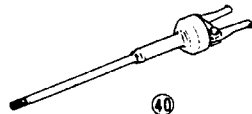

㊵



㊶

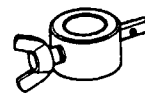

㊷



㊸

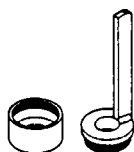

㊹

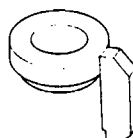

㊺

## 7. TROUBLESHOOTING

### ENGINE

#### A. HARD STARTING

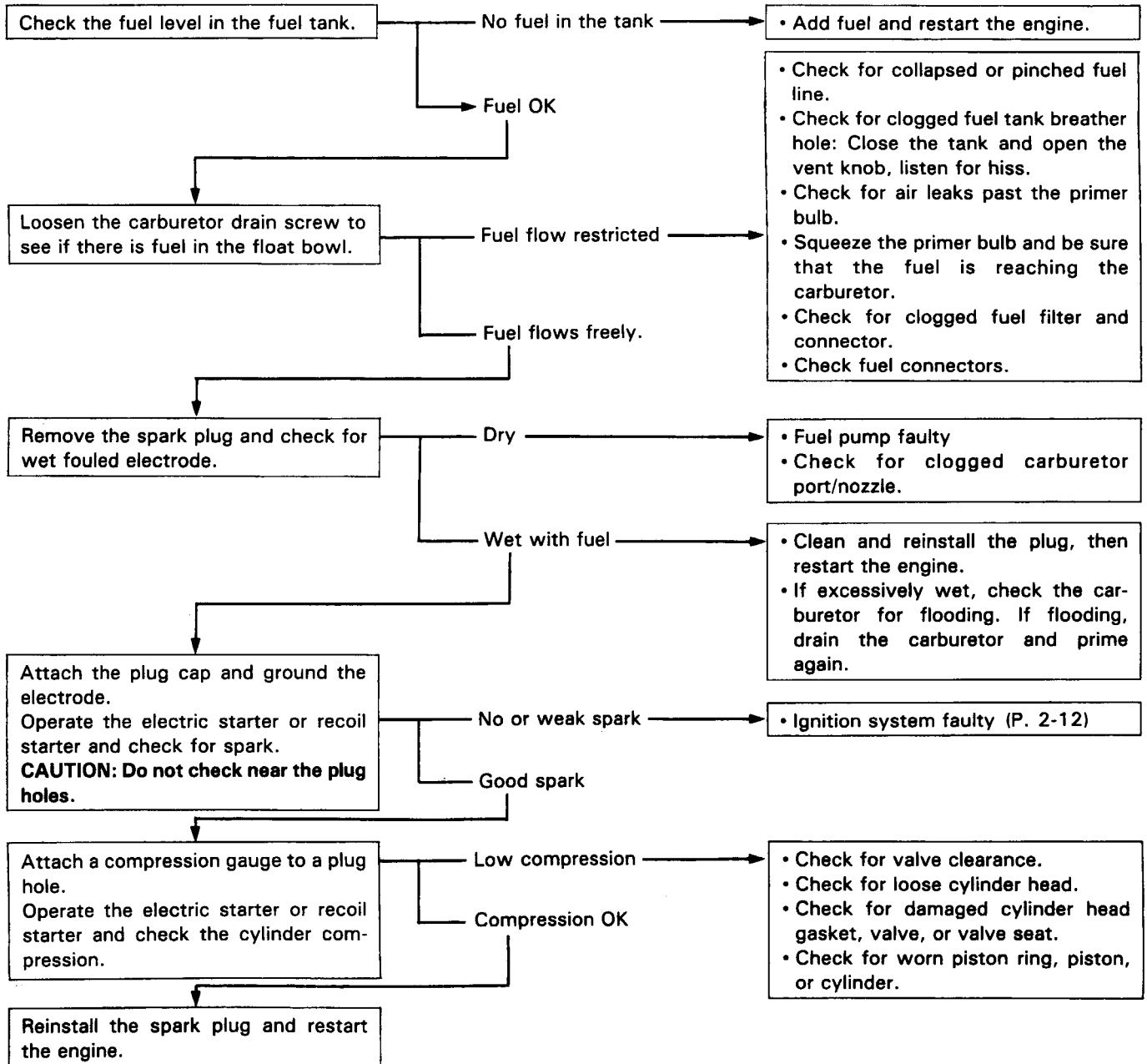

## CYLINDER COMPRESSION

- 1) Put the remote control lever or gearshift lever in the neutral position.
- 2) Disengage the emergency stop switch clip from the emergency stop switch.
- 3) Put the choke knob or choke/fast idle lever in the normal run position.
- 4) Remove the engine cover and all the spark plug caps. Remove the all spark plugs.
- 5) Carefully disconnect the throttle rod from the throttle cam (P. 3-10).
- 6) Install a compression gauge in one of the spark plug holes.
- 7) Manually hold the throttle cam in the wide open throttle position.
- 8) Using the ignition key, starter button, or recoil starter, operate the starter until the highest compression reading is obtained.

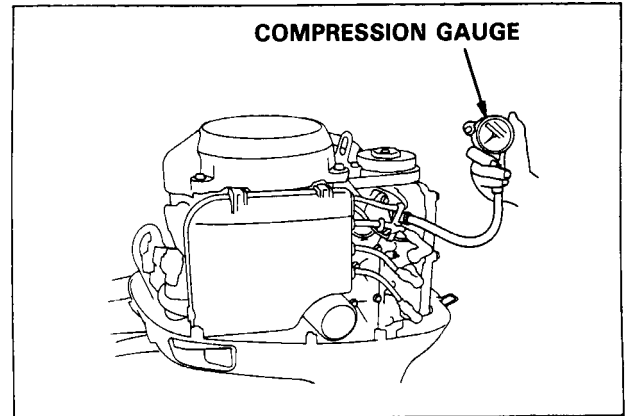

Cylinder compression	$15 \pm 1 \text{ kg/cm}^2$ (212 – 14 psi) at $500 \text{ min}^{-1}$ (rpm)
----------------------	--

### NOTE

- On the remote control type, have an assistant operate the electric starter using the ignition key.

- 9) Install the compression gauge in the other spark plug holes and repeat step 7) and 8).
- 10) Check the compression on all cylinders.

**B. IGNITION SYSTEM**

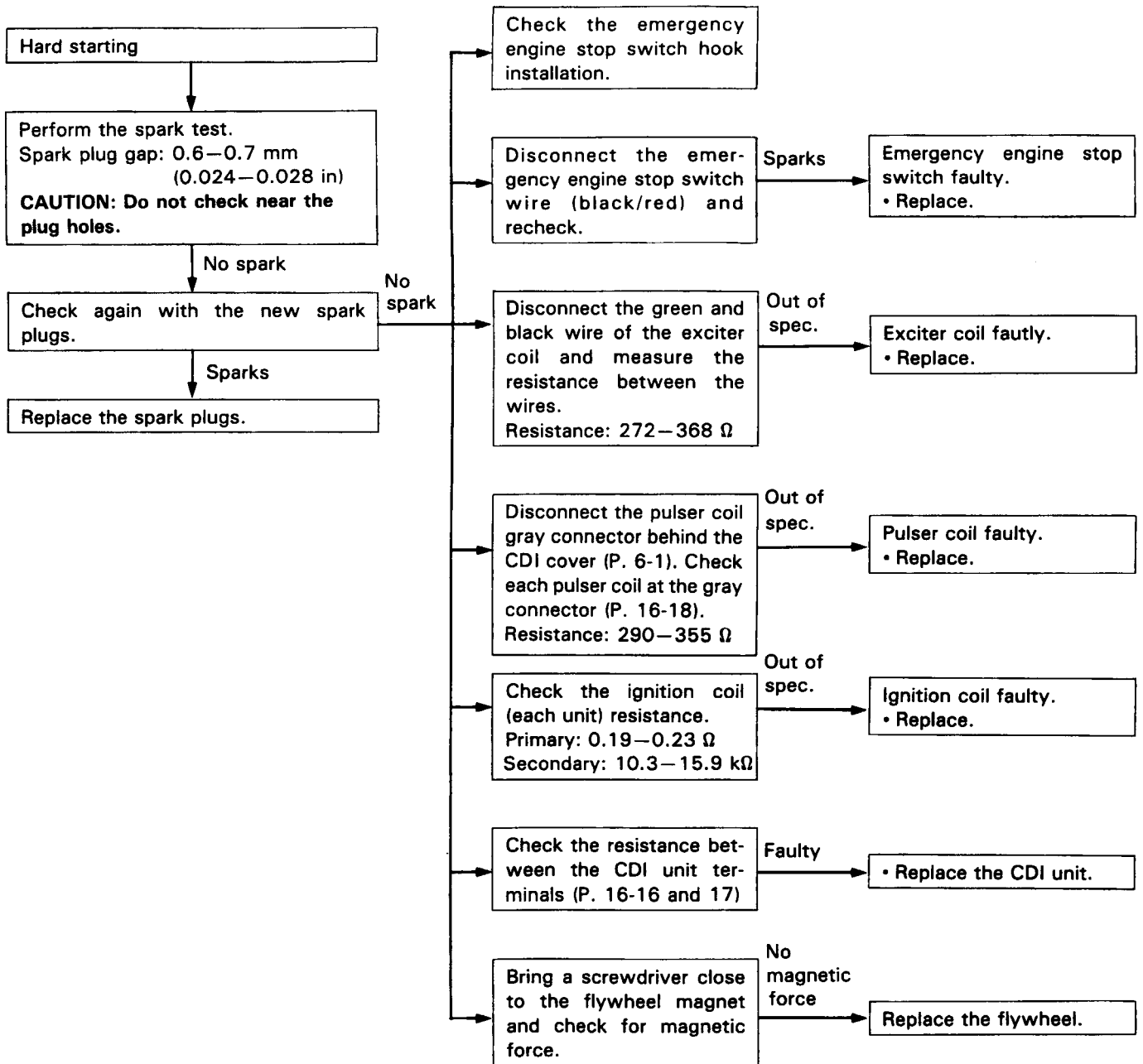

**SPARK TEST**

- 1) Put the remote control lever or gearshift lever in the neutral position.
- 2) Disconnect all the spark plug caps from the spark plugs.
- 3) Remove one of the spark plugs from the engine.
- 4) Attach a removed spark plug to a spark plug cap. Ground the negative (–) terminal of the spark plug (threads) to the water jacket cover bolt as shown.
- 5) Using the ignition key, starter button or recoil starter, operate the electric starter and check to see if sparks jump across the spark plug electrode.

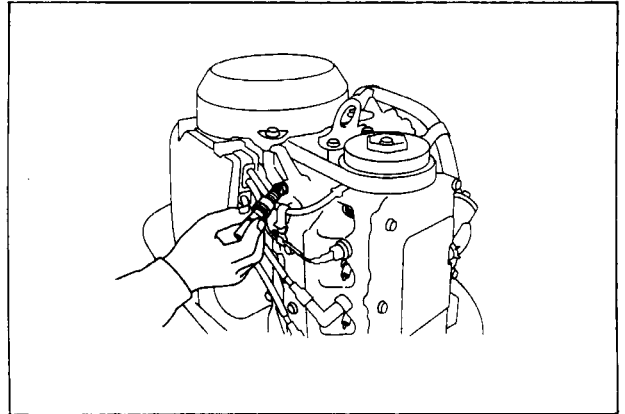
**NOTE**

- On the remote control type, have an assistant operate the electric starter using the ignition key.

- 6) Remove the spark plug from the spark plug cap and repeat steps 4 and 5 for the other cylinders.

**⚠ WARNING**

- **Never hold the spark plug wire with wet hands while performing this test.**
- **Make sure that no fuel is spilled on the engine and that the plug is not wet with fuel.**
- **To avoid fire hazards, do not allow sparks near the plug holes.**
- **Stand clear of the spark plug holes while rotating the engine.**

## C. ELECTRIC STARTER (Electric starter type only)

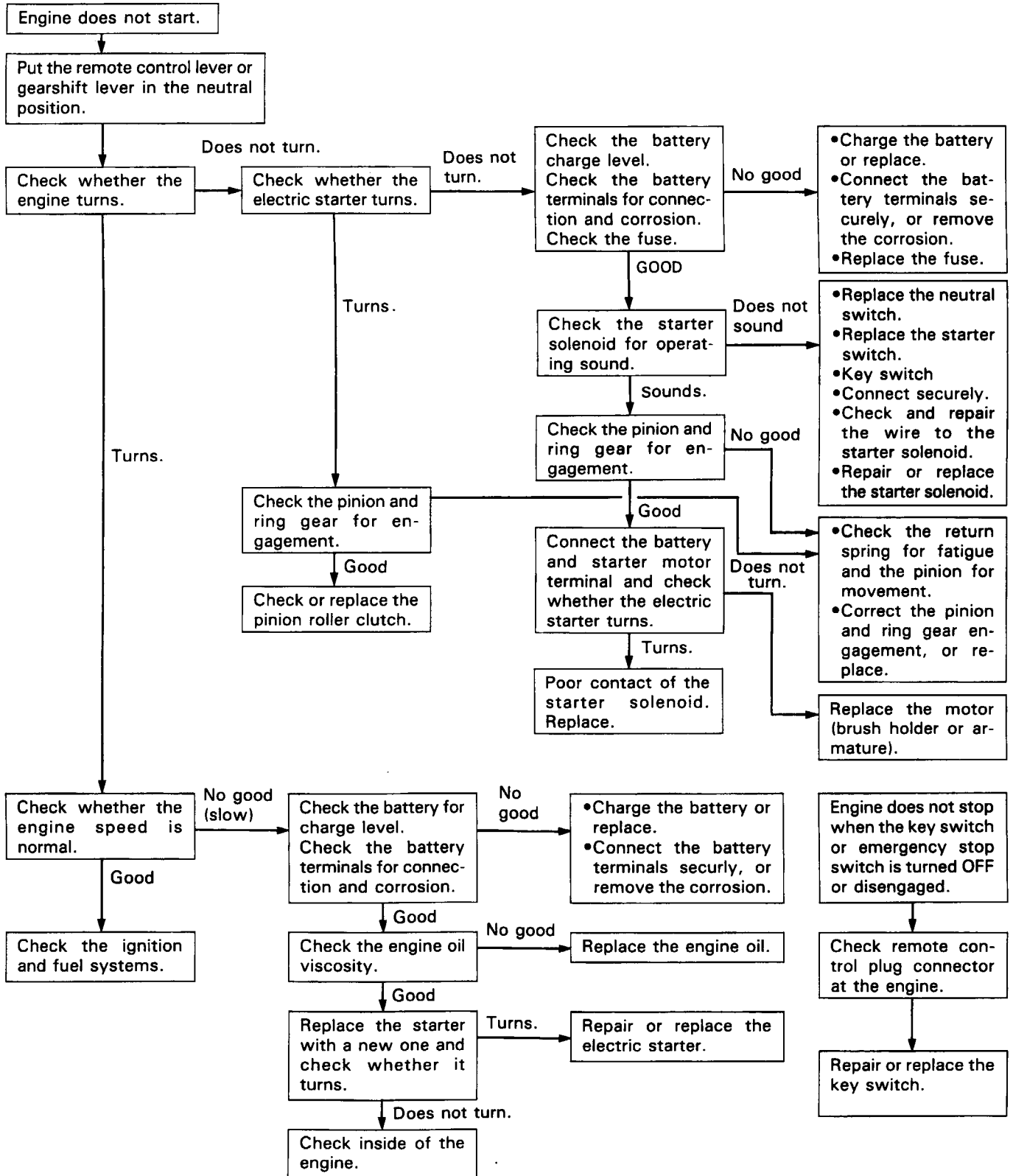

NOTE: Before repairing a problem, disconnect the battery.

### D. ENGINE DOES NOT RUN SMOOTHLY

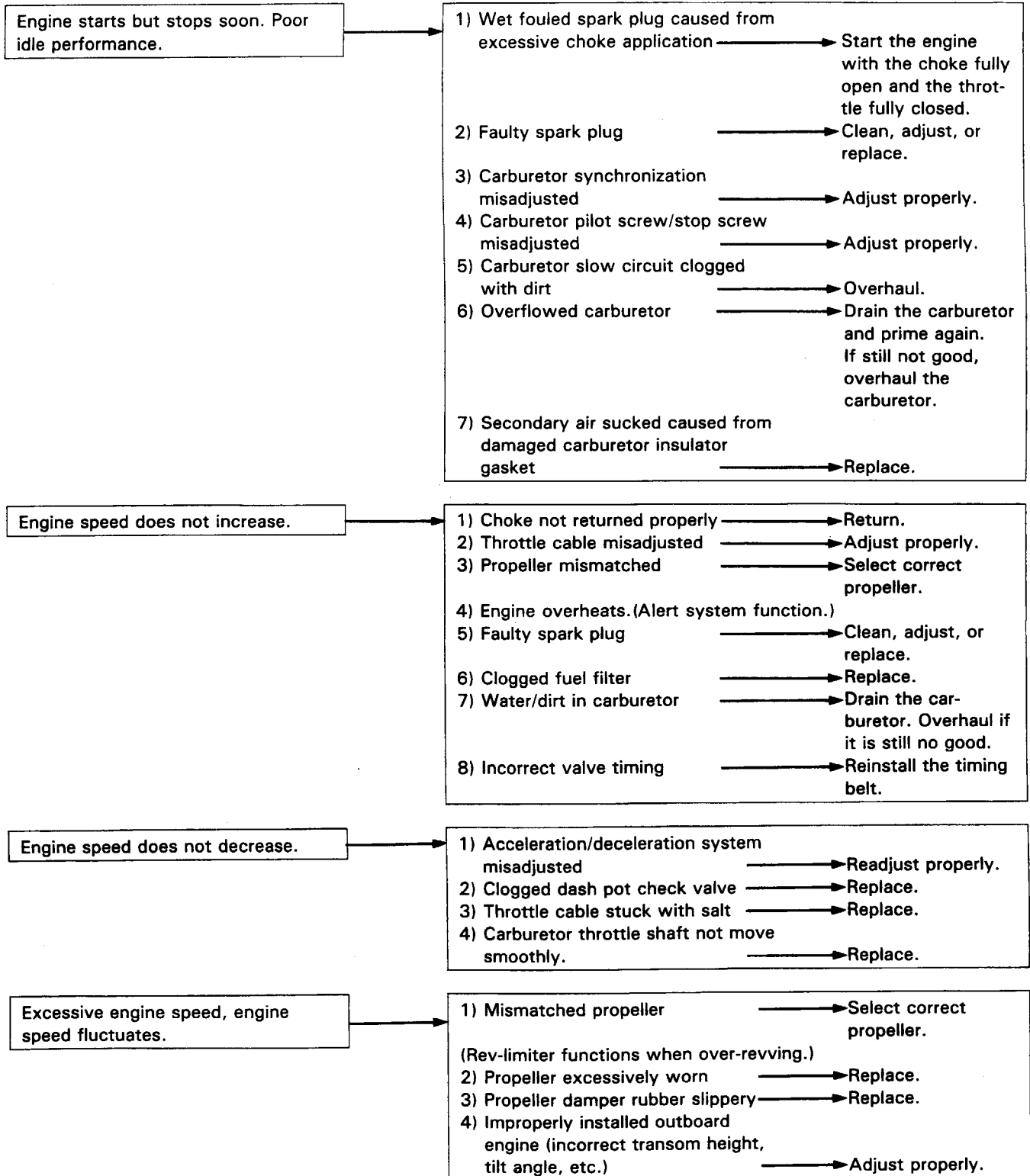

### E. ALERT SYSTEMS

#### Remote control type

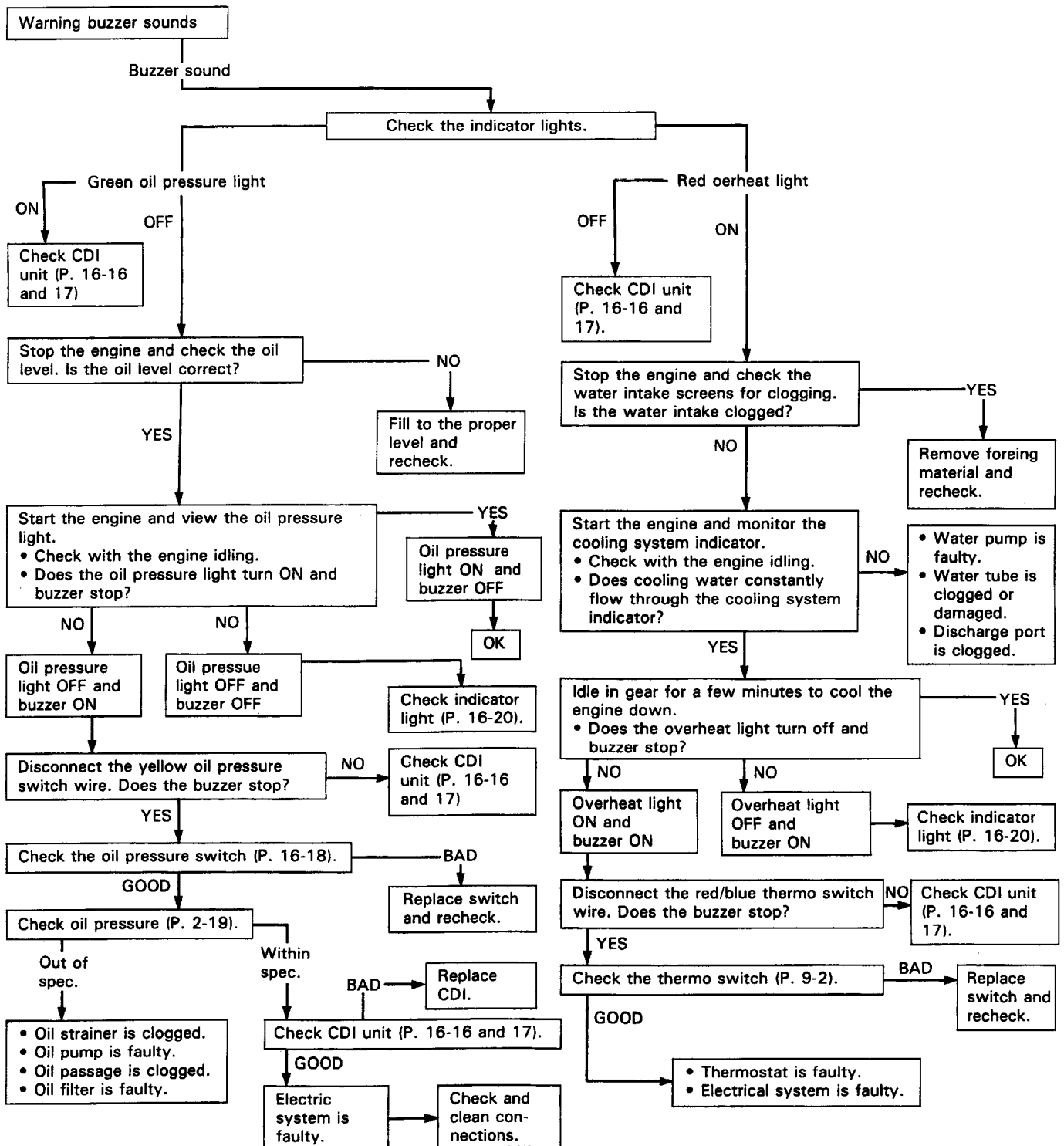

NOTE: These outboard motors are equipped with an engine over-rev limiter. The over-rev limiter is activated when the engine rpm exceeds 6,300 min<sup>-1</sup> (rpm). When activated the spark is emitted to the No. 2 and No. 3 cylinders. The over-rev limiter may be activated under such conditions as; light propeller load or propeller ventilation (refer to P. 17-3 for details on the over-rev limiter).



### Tiller handle type

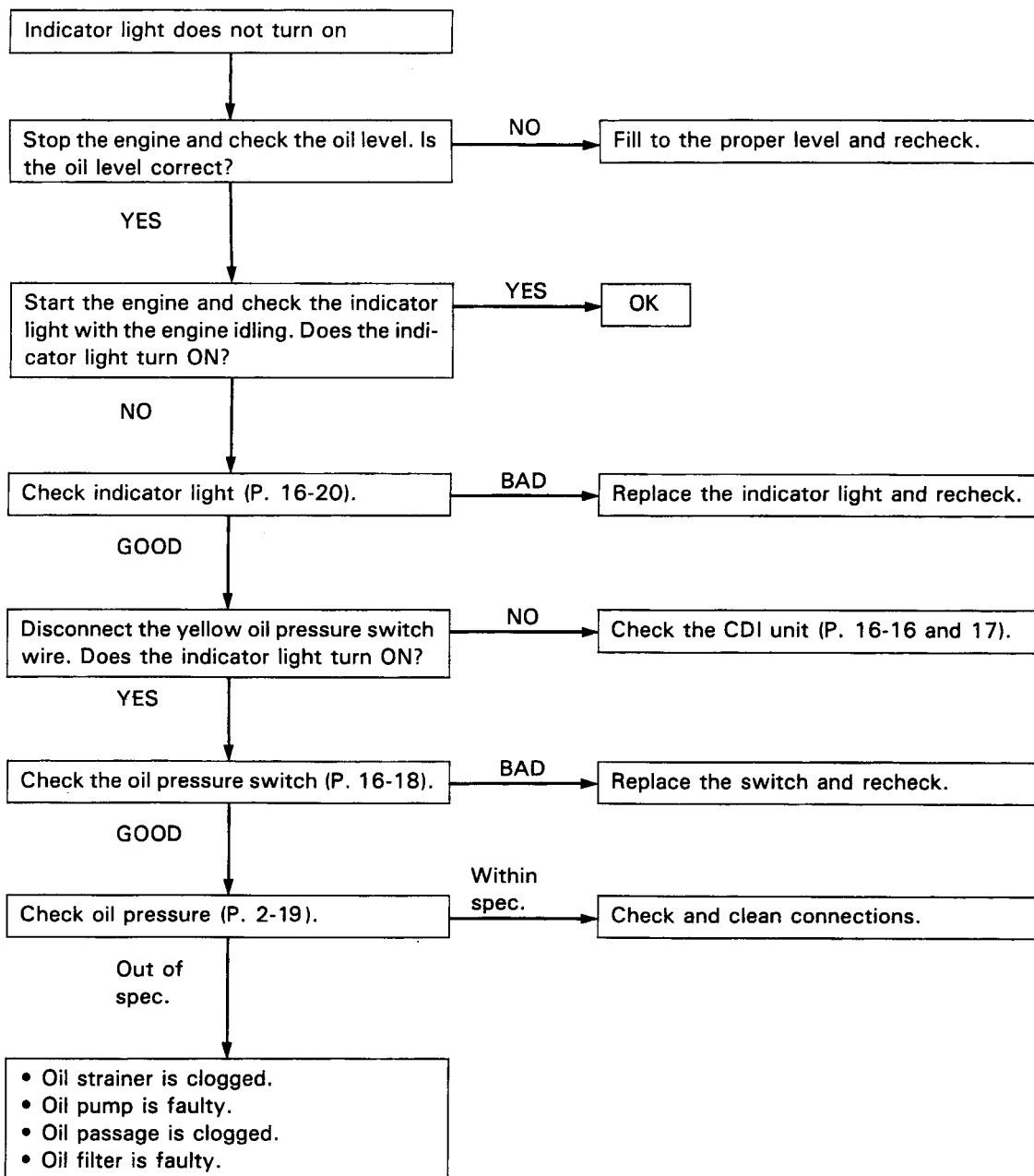

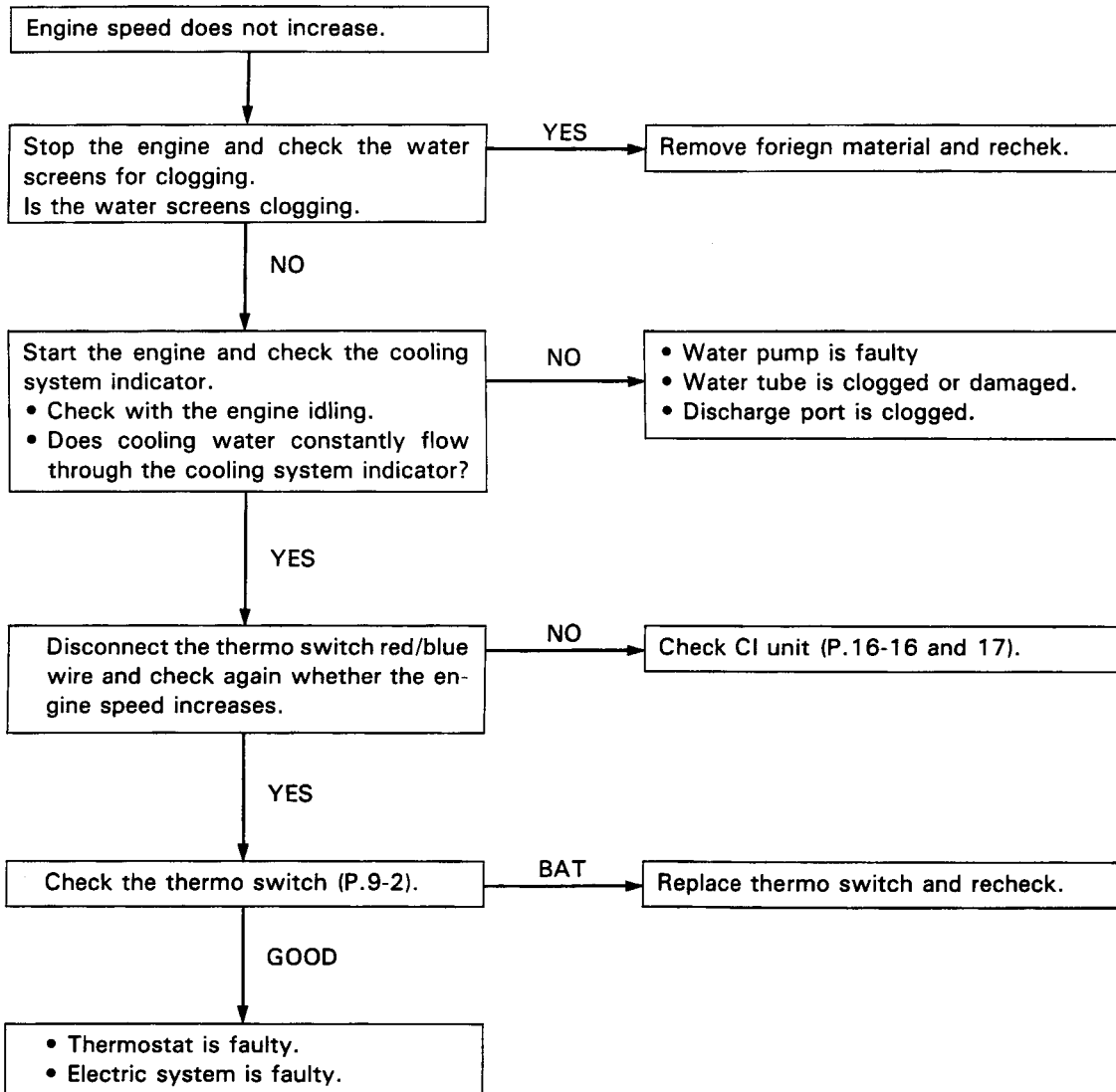

## OIL PRESSURE TEST

- 1) Check the engine oil level (P. 3-1).
- 2) Remove the 4 x 8 mm screw and oil pressure switch.

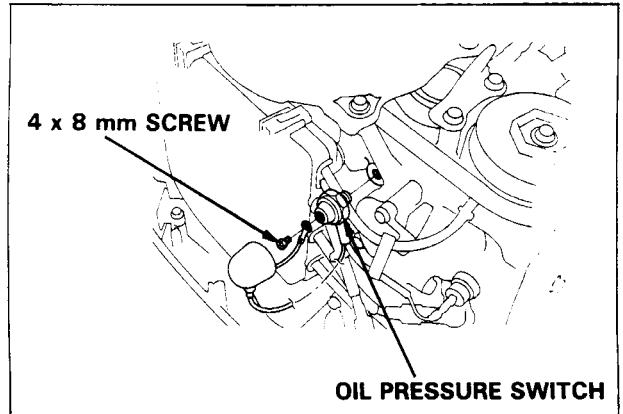

- 3) Install the pressure gauge attachment (special tool) on the oil pressure gauge that has a scale calibrated to a maximum of 0–7 kg/cm<sup>2</sup> (0–100 psi) scale and on the outboard motor.

### CAUTION

- Tighten the gauge attachment to 9 N·m (0.9 kg·m, 6.5 ft·lb).
- Overtightening will damage the threads.

- 4) Remove the propeller and set the outboard motor in a water tank or apply water to the outboard motor with the rinsing plug, and start the engine.
- 5) Measure the oil pressure when its temperature reaches 80°C (216.0°F)

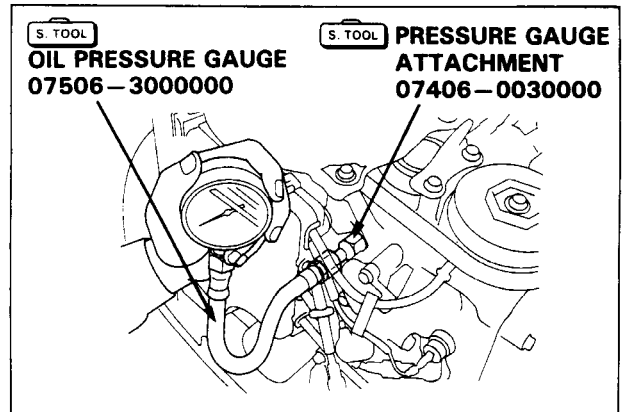

Oil pressure [Engine speed 900 ± 50 min <sup>-1</sup> (rpm) in neutral]	1.1 kg/cm <sup>2</sup> (15.6 psi) min.
---	---

- 6) If the oil pressure is less than the specification, check the oil pump rotors and body for wear.
- 7) Clean the oil pressure switch threads and apply liquid sealant (THREE BOND 1215 or equivalent) to the threads. Tighten the oil pressure switch to the specified torque.

**TORQUE: 9 N·m (0.9 kg·m, 6.5 ft·lb)**

### CAUTION

- Be sure to use a torque wrench to tighten the switch.
- Overtightening will damage the starter case.

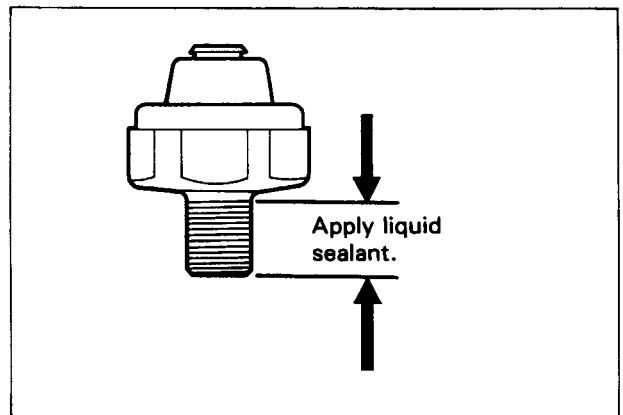

**F. SHIFT LEVER**

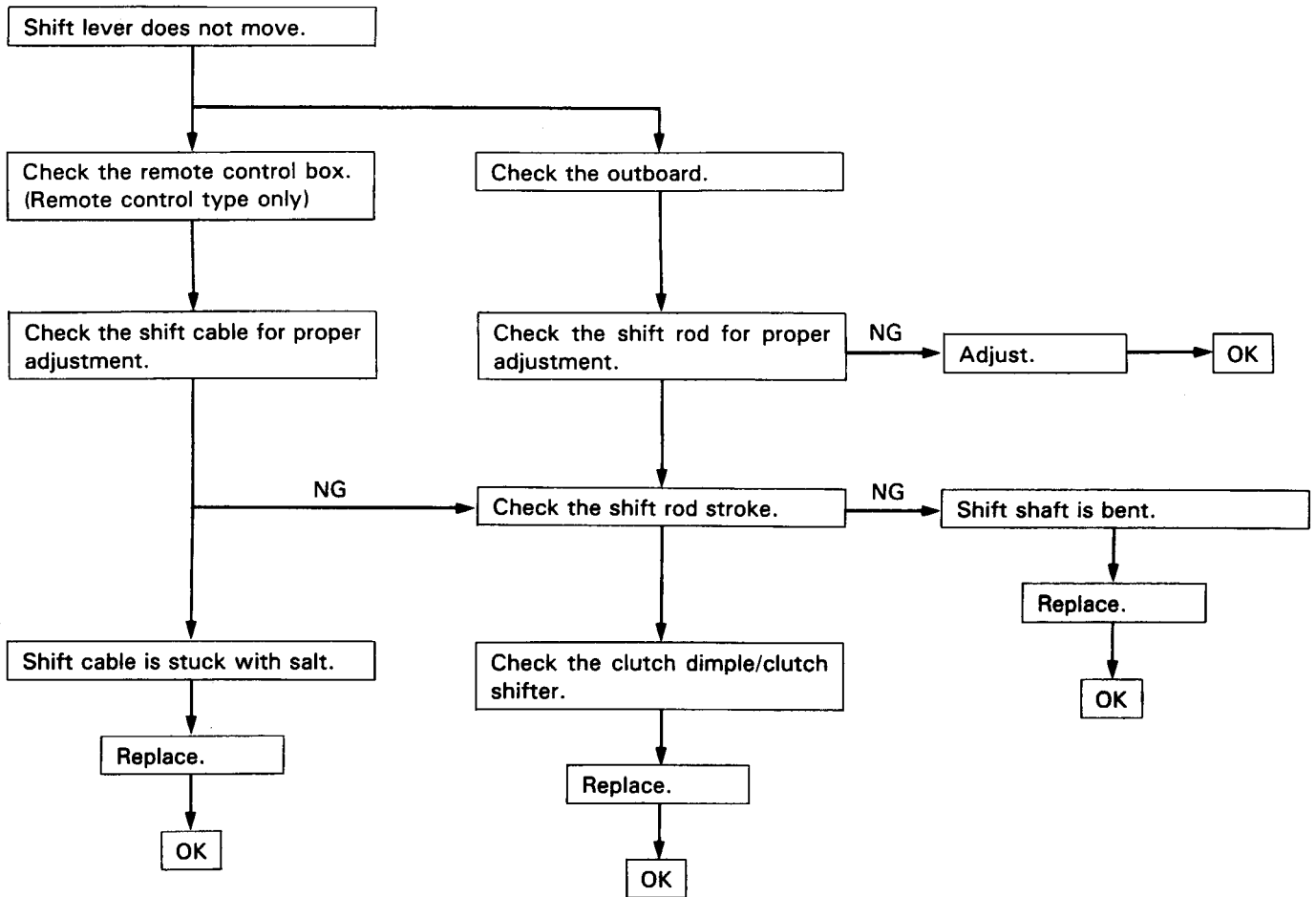

## 8. CABLE/HARNESS ROUTING

- \*1: Recoil starter type
- \*2: Electric starter type
- \*3: Remote control type

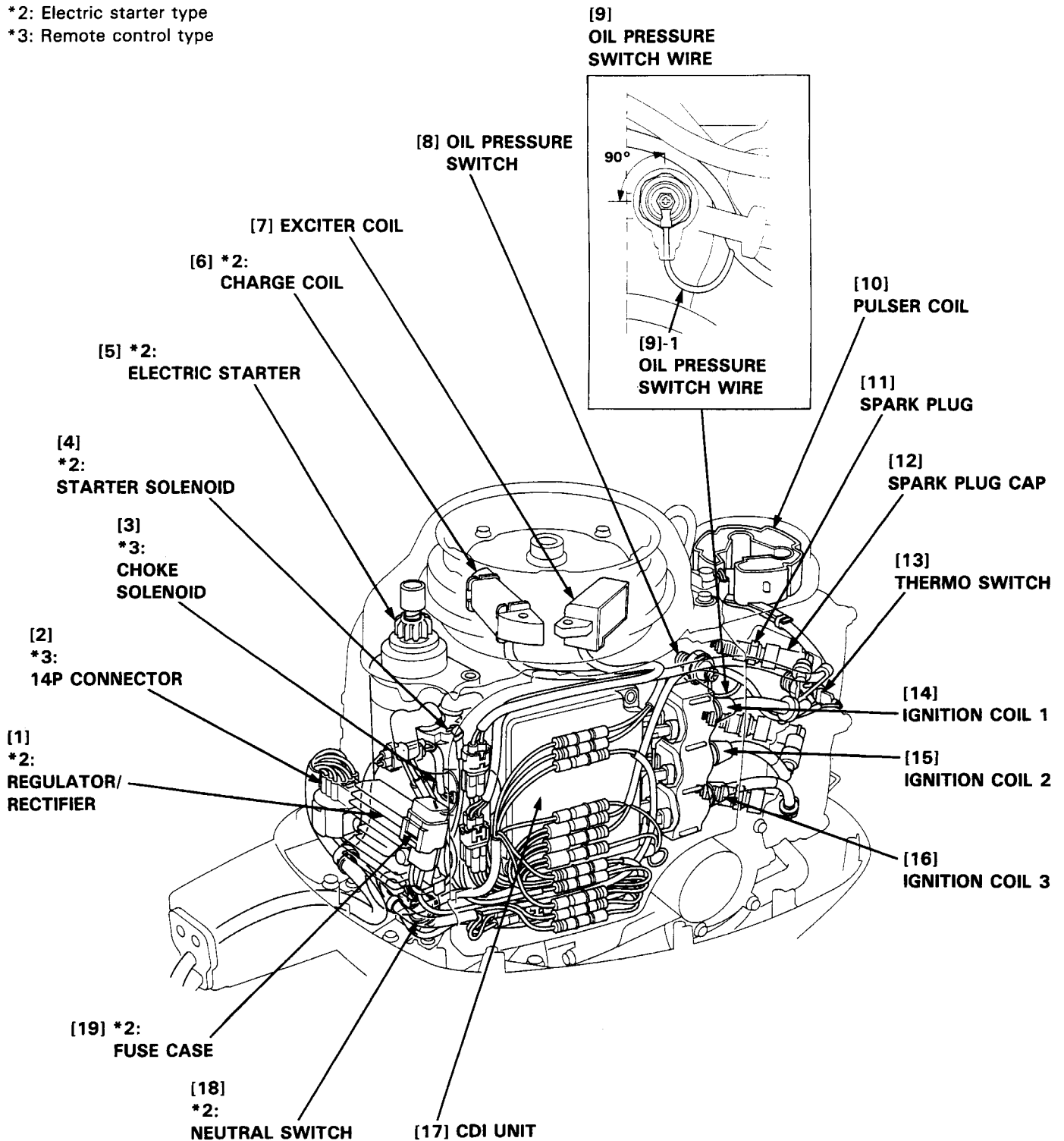

Remote control/Electric starter type:

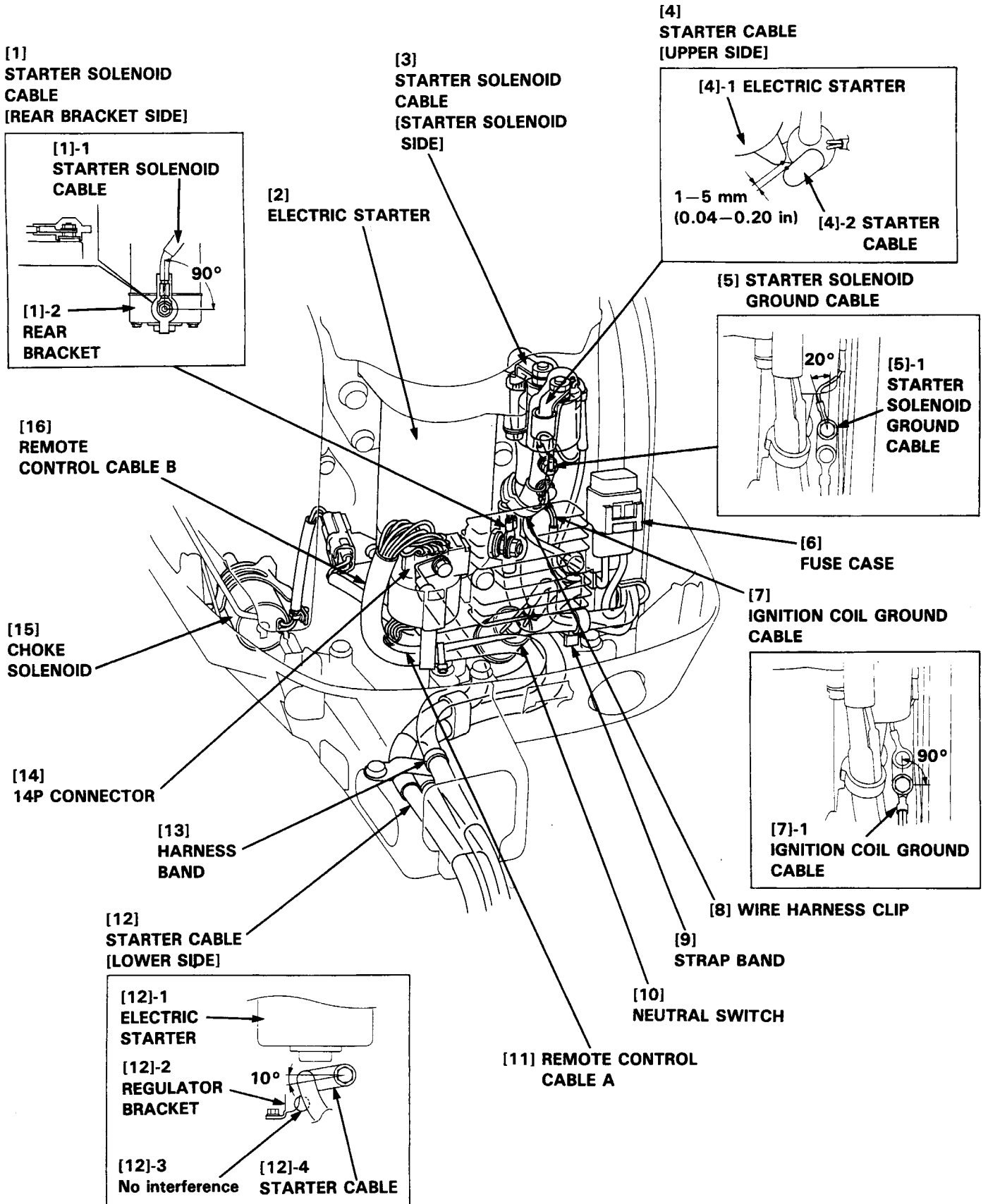

Remote control/Electric starter type:

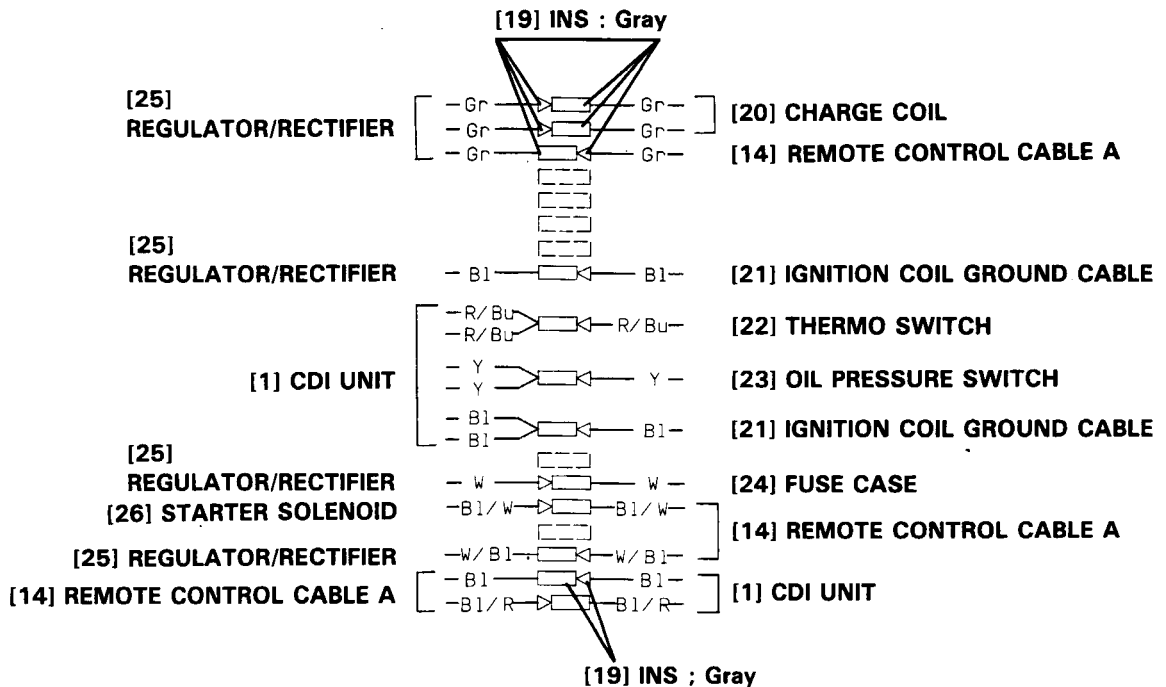
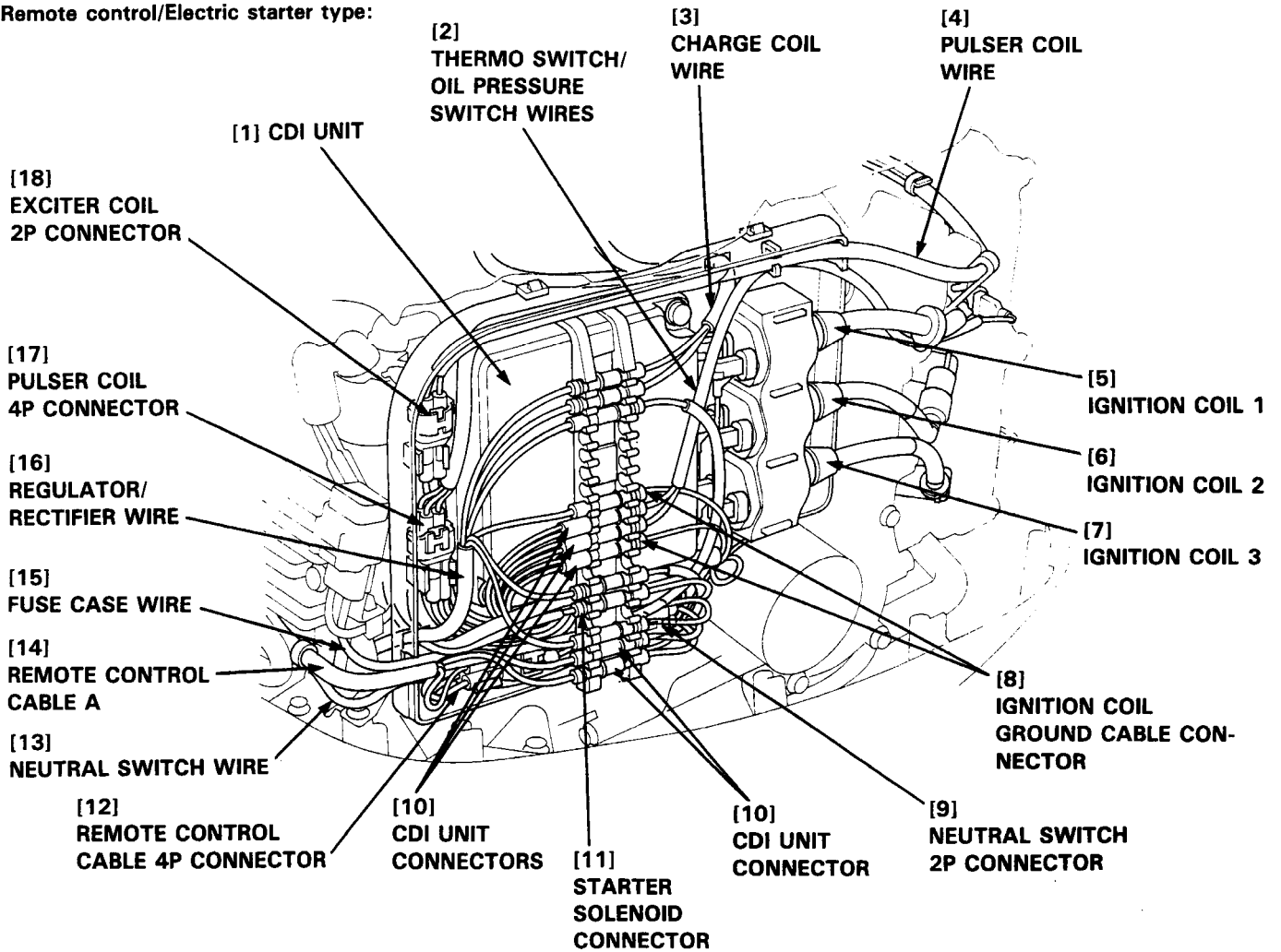

Remote control/Electric starter type:

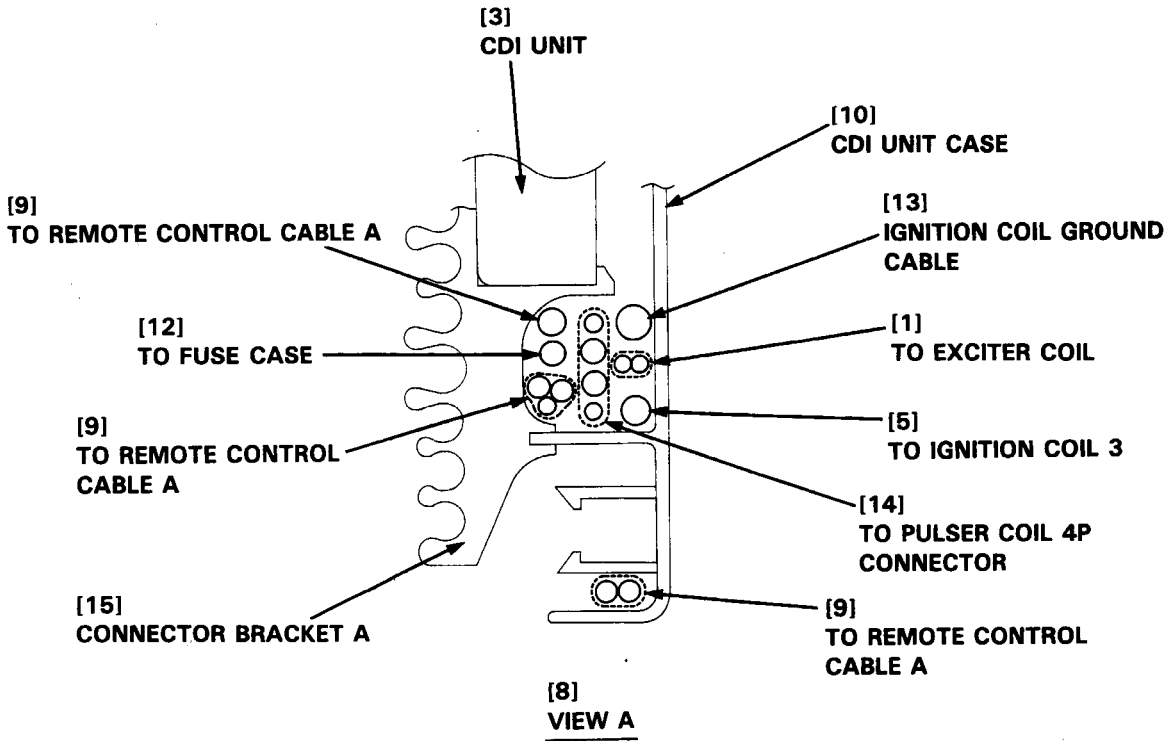
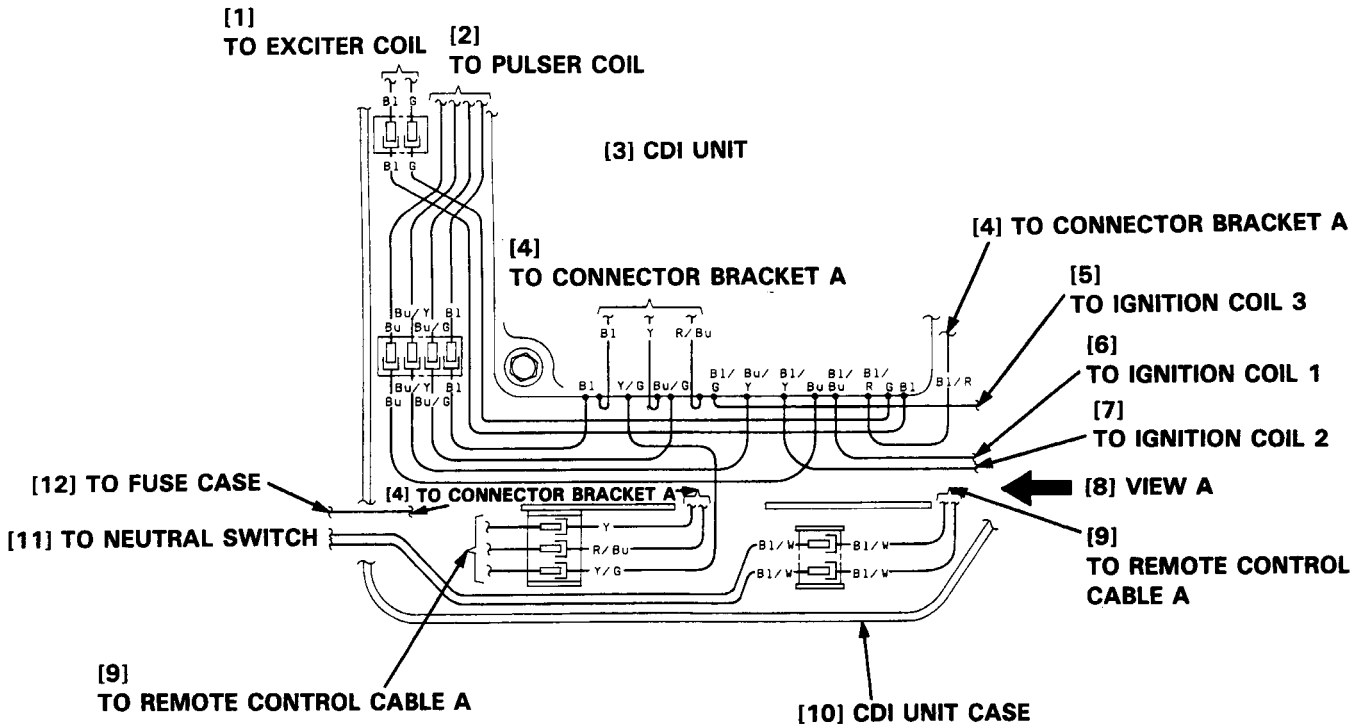





**Download the full PDF manual instantly.**

**Our customer service e-mail:**

**[aservicemanualpdf@yahoo.com](mailto:aservicemanualpdf@yahoo.com)**