

Product: TRACK-TYPE TRACTOR

Model: D8R TRACK-TYPE TRACTOR 7XM

Configuration: D8R Track-Type Tractor 7XM00001-UP (MACHINE) POWERED BY 3406 Engine

Disassembly and Assembly D8R Track-Type Tractor Power Train

Media Number -SEN8327-11

Publication Date -01/08/2018

Date Updated -17/08/2018

i01022271

Track Roller Frame - Disassemble

SMCS - 4151-015

Disassembly Procedure

Table 1

Required Tools			
Tool	Part Number	Description	Qty
A	0S-1587	Bolt (1/2 inch by 13 by 1 3/4 inch)	1
	1F-7958	Nut (1/2 inch by 13)	1
B		Bar Stock (1/2 inch by 2 inch by 10 inch)	4
C	1P-0520	Driver Gp	1
	8E-2898	Plate	1
	1H-3110	Bearing Puller	1
D	FT-2213	Strap (Group)	1
F	9U-6600	Manual Pump	1
	1U-5197	Hydraulic Cylinder	1
	1P-1838	Adapter (1 1/4 inch by 12)	1
	6V-2108	Sleeve	1
	6V-3187	Adapter (1 1/4 inch by 12)	1
	5P-4184	Tool Stud (1 1/4 inch by 12 by 18 inch)	1
G	FT-1713	Wedge	2
H	136-1452	Internal Tip Pliers	1

Start By:

- a. Remove the track roller frame. See the procedure in Disassembly and Assembly, "Track Roller Frame - Remove" in this module.



Personal injury can result from performing service on the track roller frame.

Refer to Special Instruction, SMHS8273 for inspection and removal procedures before performing any service.



Personal injury or death can result from lifting a heavy assembly.

The heavy assembly can fall if using an incorrect hoist to lift the load.

Be sure the hoist has the correct capacity to lift a heavy assembly. Approximate weight of the assembly is given below.

NOTICE

Care must be taken to ensure that fluids are contained during performance of inspection, maintenance, testing, adjusting, and repair of the product. Be prepared to collect the fluid with suitable containers before opening any compartment or disassembling any component containing fluids.

Refer to Special Publication, NENG2500, "Dealer Service Tool Catalog" for tools and supplies suitable to collect and contain fluids on Cat[®] products.

Dispose of all fluids according to local regulations and mandates.

1. Place the track roller frame on a level surface. Support each end of the track roller frame with the track guides.
-

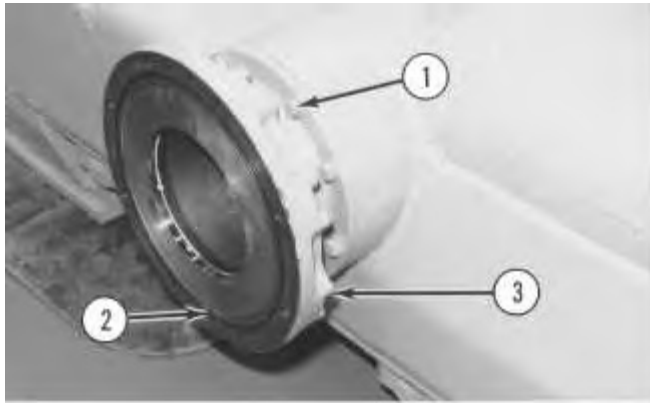

Illustration 1

g00621097

2. Remove O-ring seal (2) from seal retainer (3).
3. Remove eight bolts (1) and retainer (3) from the track roller frame.
4. Remove the O-ring seal from retainer (3) which seals between the retainer and the track roller frame.



Illustration 2

g00617654

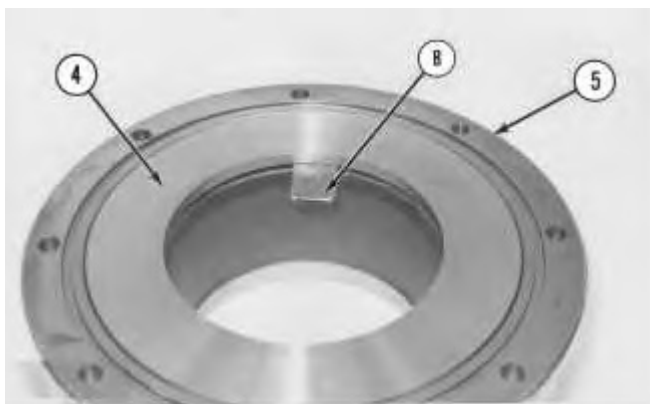

Illustration 3

g00617658

5. Position tool (A) according to Illustration 2. Rotate the nut in order to apply pressure to plate (4). When plate (4) and retainer (5) are separated sufficiently, insert tool (B) in order to keep the plate and the retainer separate. Insert bar stock (B) at four equally spaced locations around the retainer.
6. Use a soft hammer around the outer diameter of the retainer to loosen and remove plate (4).

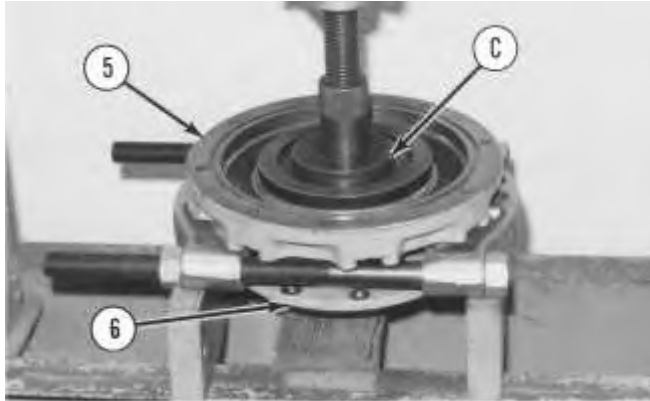

Illustration 4

g00617660

Note: The **8E-2898** Plate is the same component that is used on the end of the pivot shaft.

Note: Mark the retainers before disassembly for correct assembly in the original positions.

7. Use a hydraulic press and tool (C) to remove retainer (6) from retainer (5).



Illustration 5

g00617661

8. Use a hydraulic press to remove seal (7) from retainer (5).
-

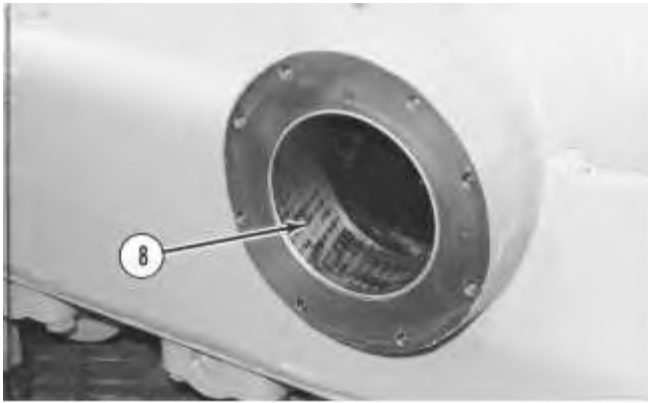

Illustration 6

g00617705

NOTICE

When these components are removed, the components are damaged or destroyed.

9. Inspect bearings (8) on each side of the track roller frame for wear and for damage. Remove the two bearings from the track roller frame, if necessary.

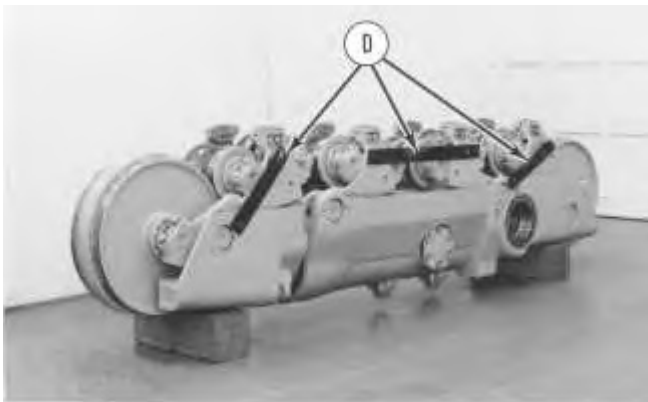

Illustration 7

g00621295

Note: The track roller frame weighs 4350 kg (9600 lb).

10. Use a suitable lifting device to position the track roller frame on wood blocks. See Illustration 7. Remove tool (D).
11. Mark the track idlers, the caps, and the shims, so that the components are assembled in the original locations. Remove the track idlers.

Reference: Refer to Disassembly and Assembly, "Idler - Remove" in this module.

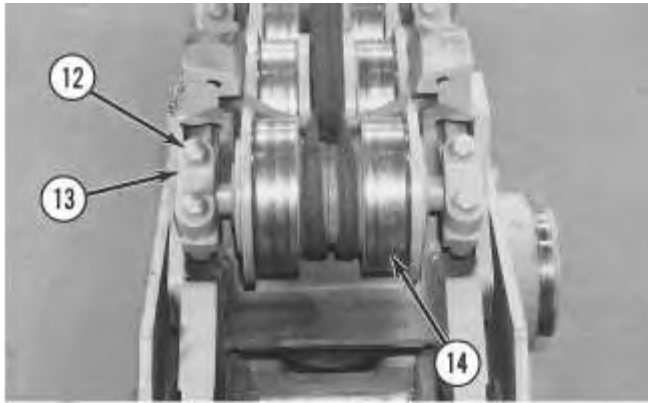

Illustration 8

g00621298

12. Mark the track rollers, the caps, and the track roller frame, so that the single flange rollers and the double flange rollers are installed in the original locations.

Reference: Refer to the procedure in Disassembly and Assembly, "Track Roller - Remove" in this module.

Note: The single flange track roller weighs 88 kg (195 lb). The double flange track roller weighs 98 kg (215 lb).

13. Fasten a suitable lifting device to track roller (14). Remove four bolts (12) and two caps (13). Remove the track roller from the minor bogie. Repeat this procedure for all of the track rollers.



Illustration 9

g00621299

14. Remove bolts (16) and track guides (15) from the major bogies.

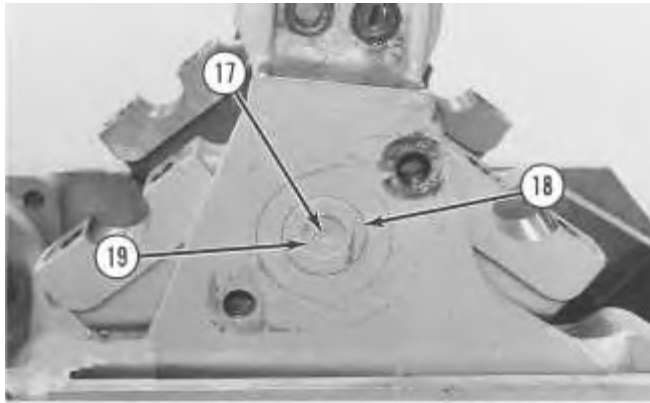

Illustration 10

g00621306

Note: Removal of the plugs and stoppers releases oil.

15. Use a variable speed drill to remove plug (17) and stopper (19) from each end of cartridge pin (18).

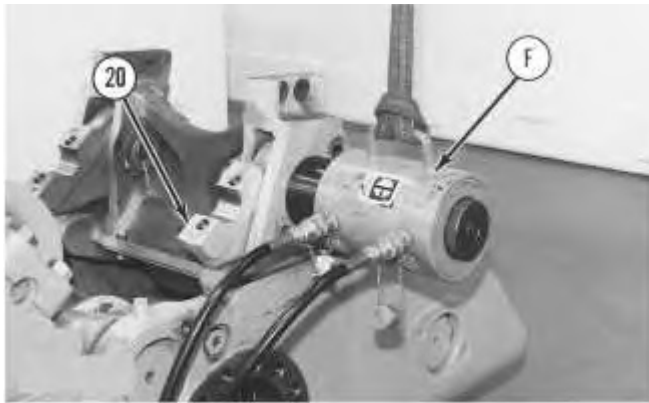
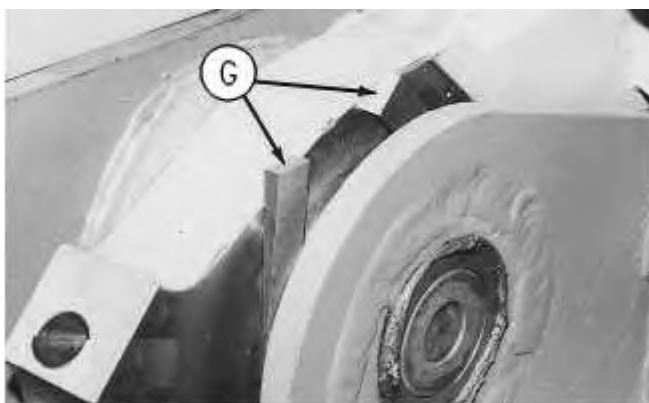

Illustration 11

g00621307

16. Install tool (F) on the major bogie. Suspend the tool by a lifting device. See Illustration 11. Remove cartridge pin (18).
17. Remove minor bogie (20) from the major bogie.
18. Repeat Steps 15 through 17 for the remainder of the minor bogies.



19. Install tool (G) between the track roller frame and the major bogie in order to hold the components in place during the removal of the cartridge pins.

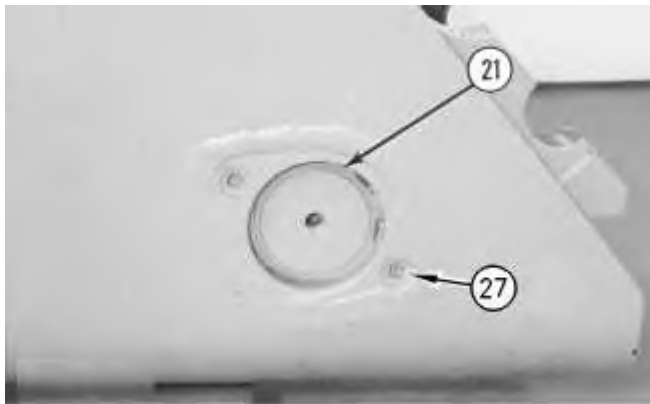

Illustration 13

20. Use tool (H) to remove retaining ring (21) from each side of the track roller frame.

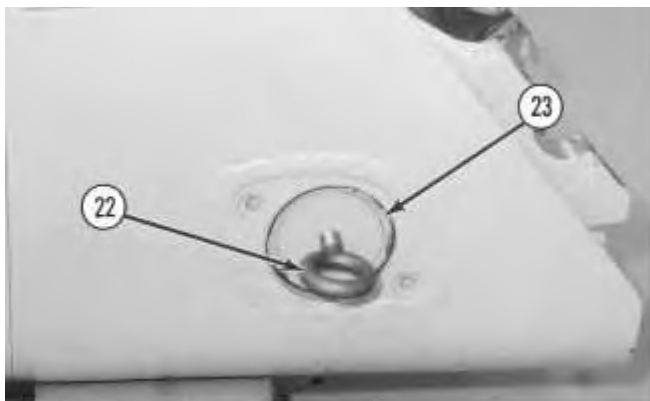
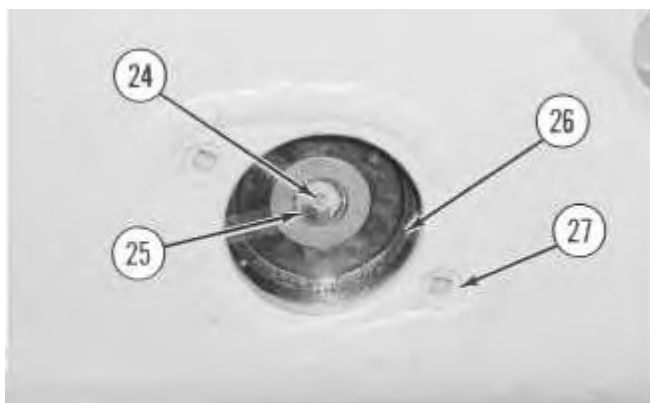

Illustration 14

21. Install one 5/8 inch by 11 NC eyebolt (22) in plate (23). Remove plate (23) from each side of the track roller frame.





Download the full PDF manual instantly.

Our customer service e-mail:

aservicemanualpdf@yahoo.com