

Product: TRACK-TYPE TRACTOR

Model: D8N TRACK-TYPE TRACTOR 9TC

Configuration: D8N TRACTOR 9TC00001-UP (MACHINE) POWERED BY 3406 ENGINE

## Disassembly and Assembly C11 and C13 Engines for Caterpillar Built Machines

Media Number -REN9214-23

Publication Date -01/05/2015

Date Updated -22/05/2018

i06931709

# Gear Group (Rear) - Remove and Install

SMCS - 1206-010; 1212-010

## Removal Procedure

Table 1

Required Tools			
Tool	Part Number	Part Description	Qty
A	1P-0520	Driver Gp.	1
B	1P-0510	Driver Gp	1

### Start By:

- a. Remove the electric starting motor.
- b. Remove the flywheel.
  1. Support the engine.

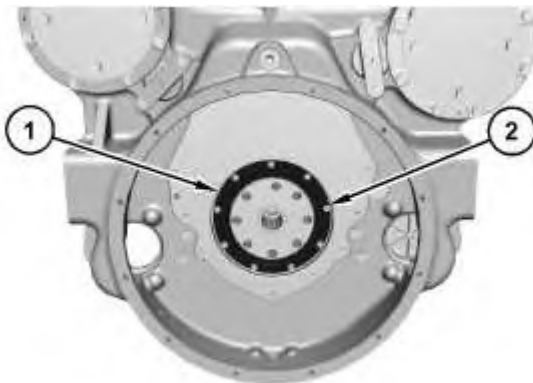

2. Remove bolts (2) and rear crankshaft seal (1).



3. Remove bolts (4) and the washers. Remove cover (3) and the seal.

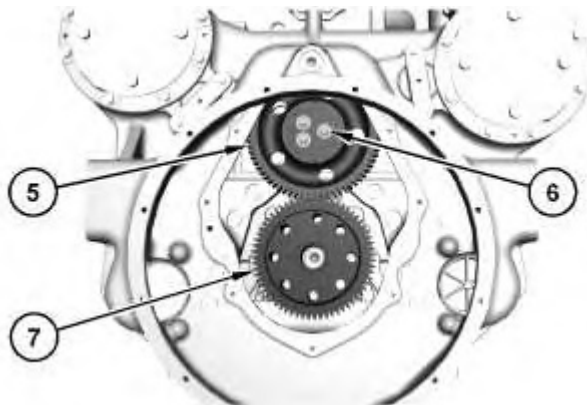

4. Remove gear (7), bolts (6), and gear (5).



5. Remove O-ring seal (8) from gear (7).



Illustration 5

g06172622

6. Use Tooling (A) to remove bushing (7A) from gear assembly (7).



Illustration 6

g06172537

7. Remove bolts (9), adapter assembly (10), and the O-ring seal.

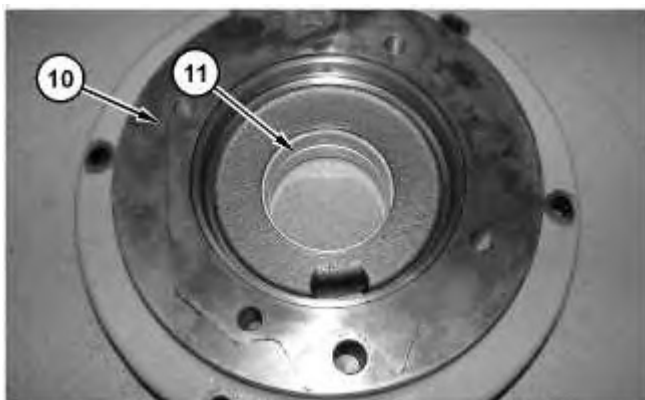

Illustration 7

g06172541

8. Use Tooling (B) to remove bearing (11) from adapter assembly (10).
-



Illustration 8

g06172549

9. Remove gear assembly (12).

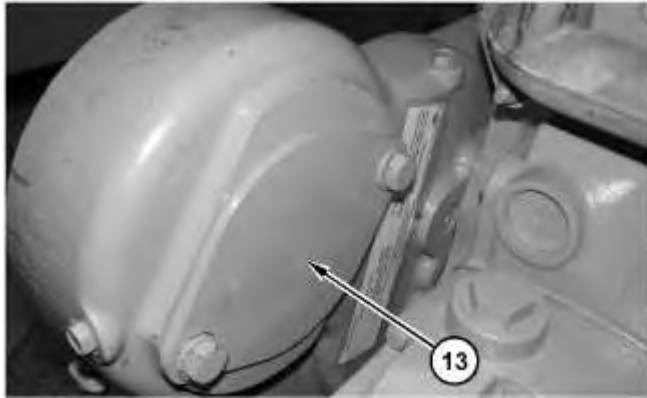

Illustration 9

g06172554

10. Remove cover (13) and the O-ring seal.



Illustration 10

g06172557

11. Use Tooling (B) to remove bearing (14).

## Installation Procedure

Table 2

Required Tools			
Tool	Part Number	Part Description	Qty
A	095-0706	Bolt	2



Illustration 11

g06172557

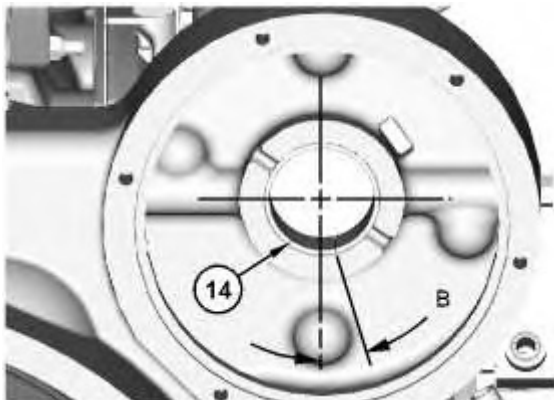

Illustration 12

g06172580

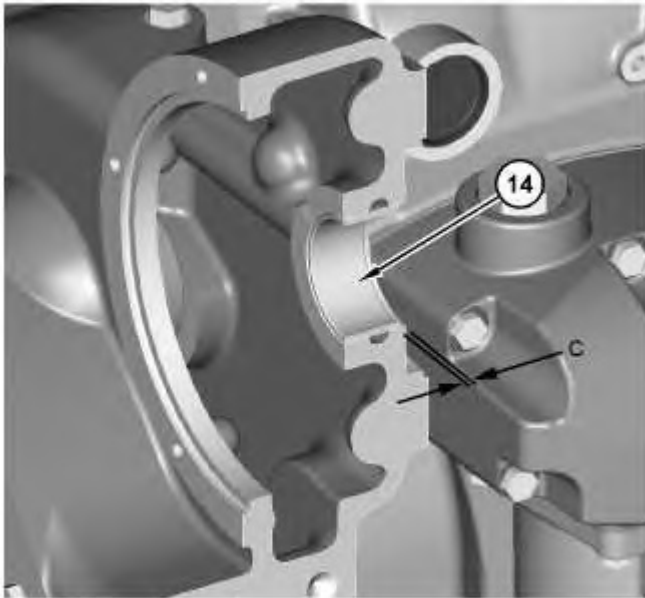

Illustration 13

g06172587

1. Lower the temperature of bearing (14). Be sure to match Dimension (B) and Dimension (C) when installing bearing (14.). Dimension (B) indicates the angle of the joint on bearing (14.). Dimension (B) is  $15^{\circ} \pm 1^{\circ}$ . Dimension (C) shows the distance from bearing (14) to the end of the bore. Dimension (C) is  $4.000 \pm 0.500$  mm ( $0.1575 \pm 0.0197$  inch).

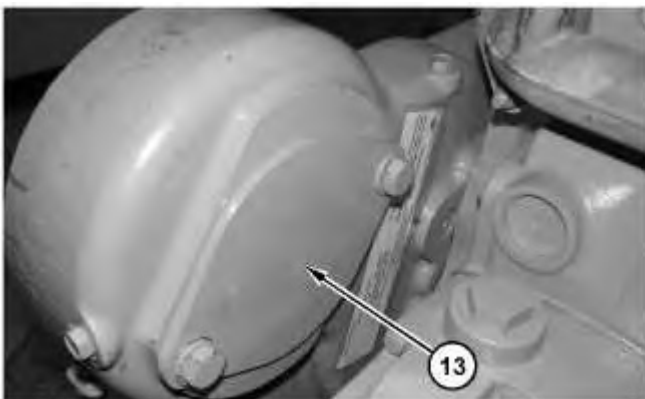

Illustration 14

g06172554

2. Install the O-ring seal and cover (9).



Illustration 15

g06172597

3. Install gear assembly (12) with oil passage plug (12A) facing out.

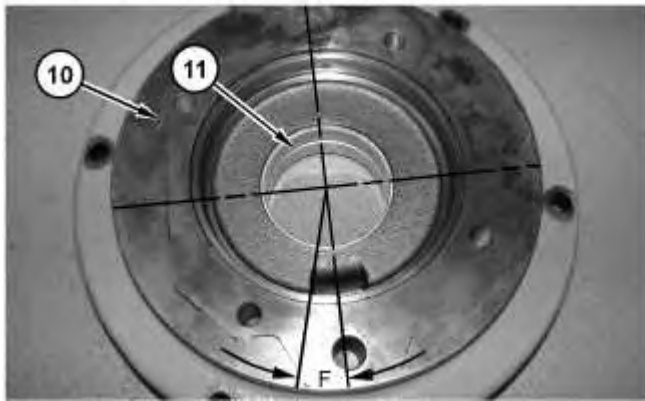

Illustration 16

g06172601

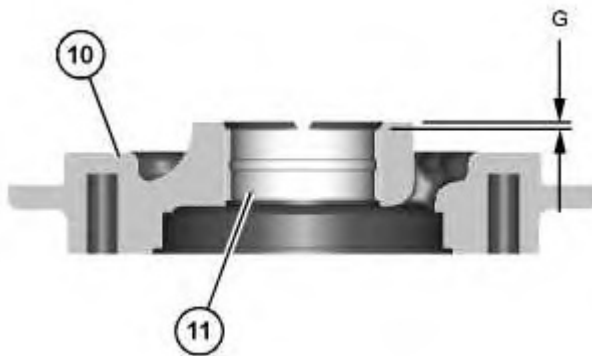

Illustration 17

g06172609

4. Lower the temperature of bearing (11). Be sure to match Dimension (F) and Dimension (G) when installing bearing (11) into adapter assembly (10). Dimension (F) indicates the angle of the joint on bearing (11). Dimension (F) is  $15^\circ \pm 1^\circ$ . Dimension (G) shows the distance from bearing (11) to the end of the bore. Dimension (G) is  $3.500 \pm 0.500$  mm ( $0.1378 \pm 0.0197$  inch).



Illustration 18

g06172537

5. Install the O-ring seal, adapter assembly (10), and bolts (9).

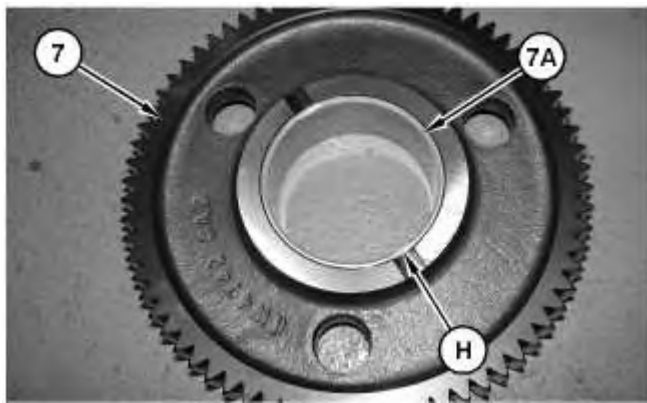

Illustration 19

g06172619

6. Lower the temperature of bearing (7A). Install bearing (7A) into gear assembly (7). Be sure that each relief (H) is within 2° of each relief in gear assembly (7).



Illustration 20

g06002564

7. Install O-ring seal (8) onto gear (7).





**Download the full PDF manual instantly.**

**Our customer service e-mail:**

**[aservicemanualpdf@yahoo.com](mailto:aservicemanualpdf@yahoo.com)**