

Product: MINI HYD EXCAVATOR

Model: 305.5D MINI HYD EXCAVATOR FLZ

Configuration: 305.5D Mini Excavator FLZ00001-UP (MACHINE) POWERED BY S4Q2T Engine

## Disassembly and Assembly

### 303.5D CR, 304D CR, 305D CR and 305.5D CR Mini Hydraulic Excavators Machine Systems

Media Number -UENR0102-01

Publication Date -01/12/2014

Date Updated -17/12/2014

i03983341

## Swing Motor and Swing Drive - Assemble

SMCS - 5058-016-ZW; 5459-016

### Assembly Procedure

Table 1

Required Tools			
Tool	Part Number	Part Description	Qty
B	1P-1863	Retaining Ring Pliers	1

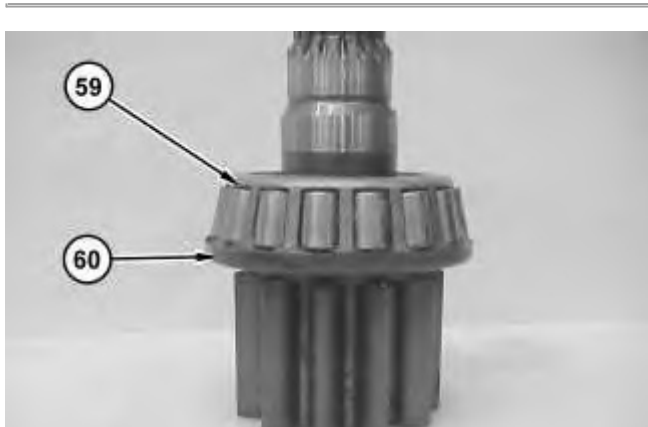

Illustration 1

g01229399

1. Raise the temperature of bearing cone (59) .
2. Install dust cap (60) and bearing cone (59) .

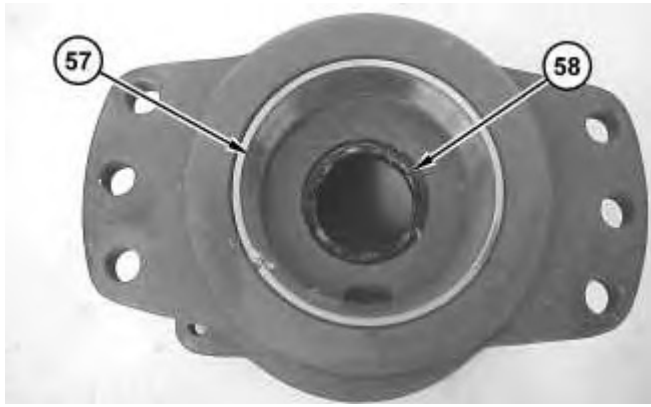

Illustration 2

g01229396

3. Install bearing cup (57) and lip seal (58) .



Illustration 3

g01229395

4. Install bearing cup (56) .

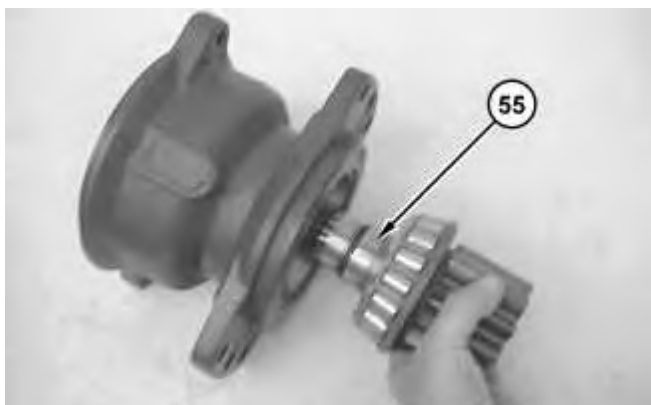

Illustration 4

g01229394

5. Install shaft assembly (55) .

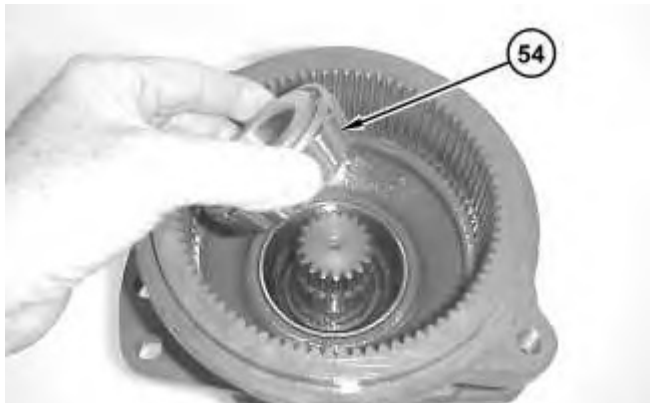

Illustration 5

g01229392

6. Install bearing cone (54) .

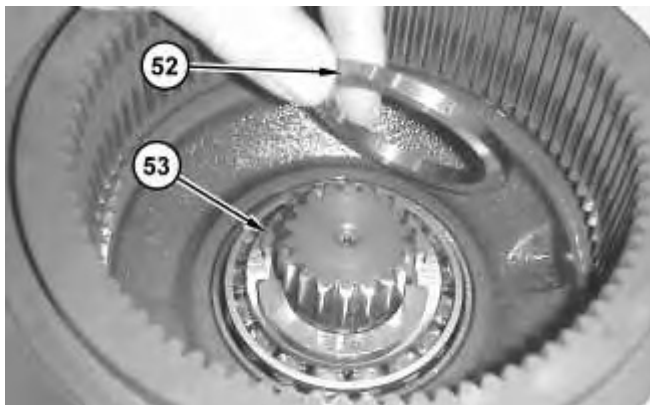
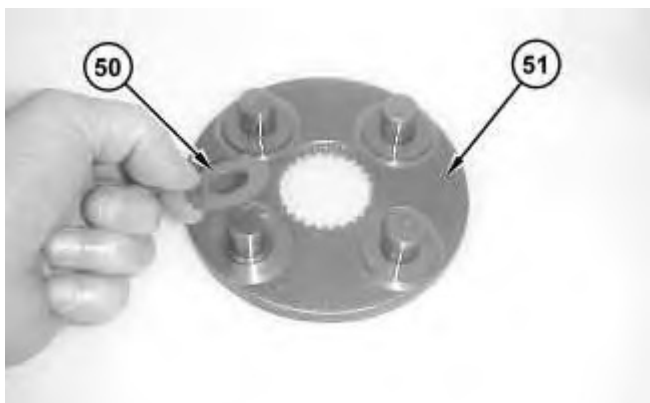

Illustration 6

g01229391

7. Install retainers (53) and retainer (52) .



8. Install washers (50) onto carrier (51) .



Illustration 8

9. Install gears (48) and bearings (49) .

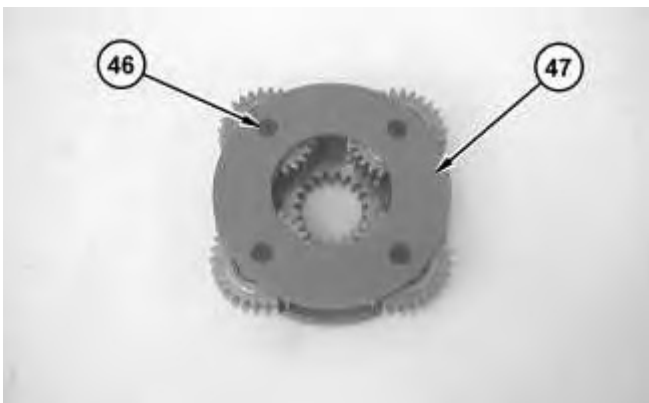

Illustration 9

10. Install plate (47) and screws (46) .
-

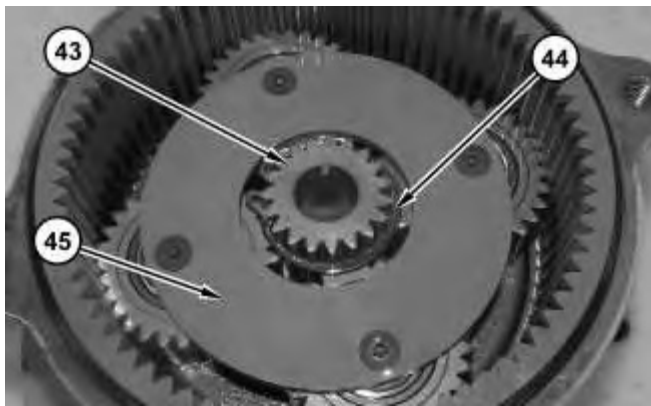

Illustration 10

g01228850

11. Install carrier (45) .
12. Use Tooling (B) in order to Install retaining ring (44) .
13. Install sun gear (43) .

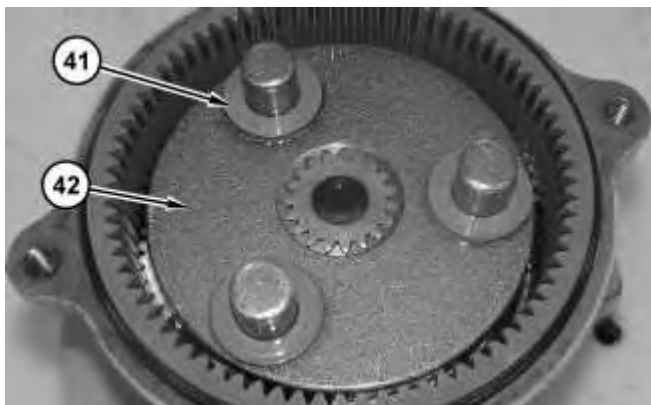
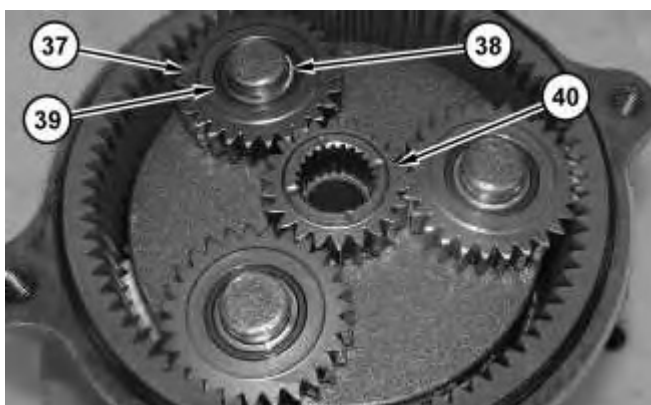

Illustration 11

g01228848

14. Install carrier (42) and washers (41) .



15. Install bearings (38), races (39), and gears (37) .
16. Install gear (40) .



Illustration 13

17. Install O-ring seal (35) and plate (36) .



Illustration 14

18. Install O-ring seal (34), backup rings (33), O-ring seal (32), and nut (31) .
-

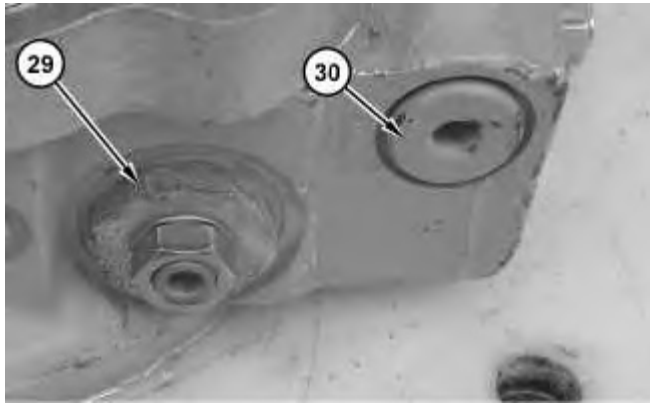

Illustration 15

g01228851

19. Install valve assembly (29), the O-ring seal, and plug (30) .

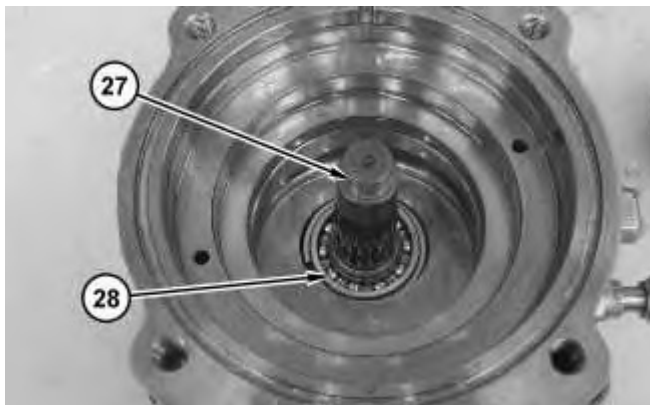
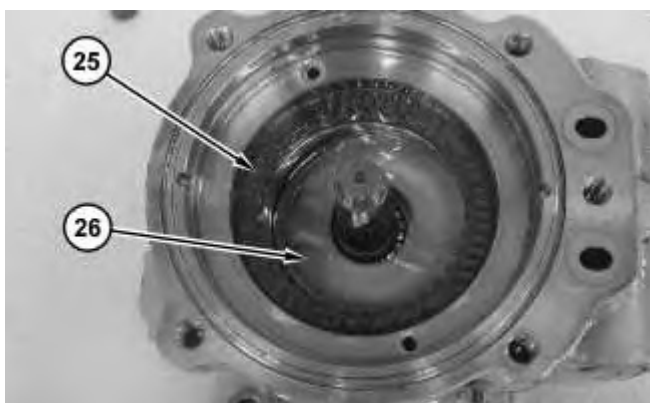

Illustration 16

g01228843

20. Raise the temperature of bearing (28) .
21. Install bearing onto shaft (27) .
22. Install shaft (27) and bearing (28) .



23. Install plate (26) and disc (25) .



Illustration 18

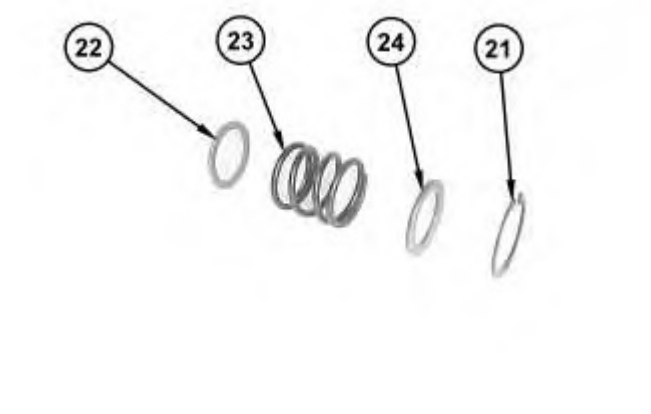

Illustration 19

 **WARNING**

**Improper assembly of parts that are spring loaded can cause bodily injury.**

**To prevent possible injury, follow the established assembly procedure and wear protective equipment.**

---

24. Install washer (22), spring (23), and washer (24) .
25. Use a suitable press and Tooling (B) in order to install retaining ring (21) .





Illustration 20

g01228837

26. Install pins (20) .



Illustration 21

g01228836

27. Install bearing (19), retainer (18), and pistons (17) .

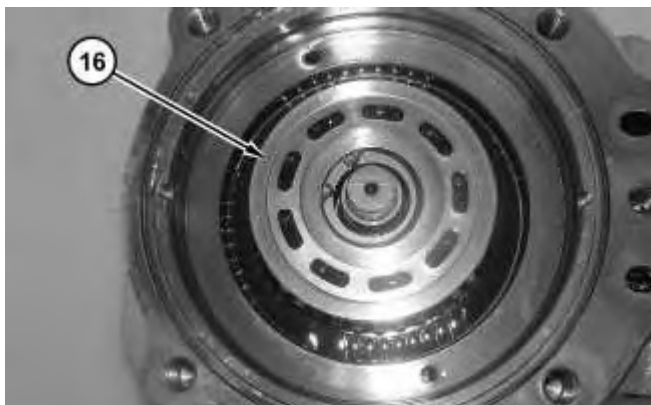

28. Install rotating group (16) .

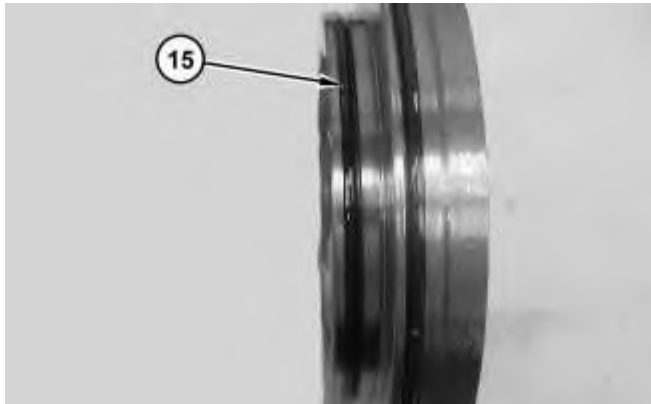

29. Install O-ring seals (15) .

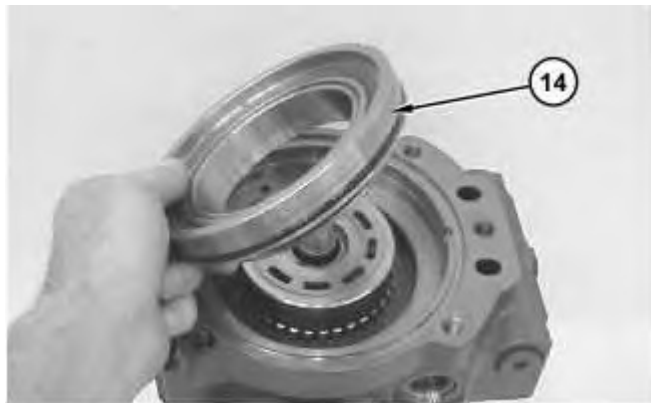

30. Install piston (14) .

---



**Download the full PDF manual instantly.**

**Our customer service e-mail:**

**[aservicemanualpdf@yahoo.com](mailto:aservicemanualpdf@yahoo.com)**