

7

4

2

B

7

4

3

B



# Service Manual

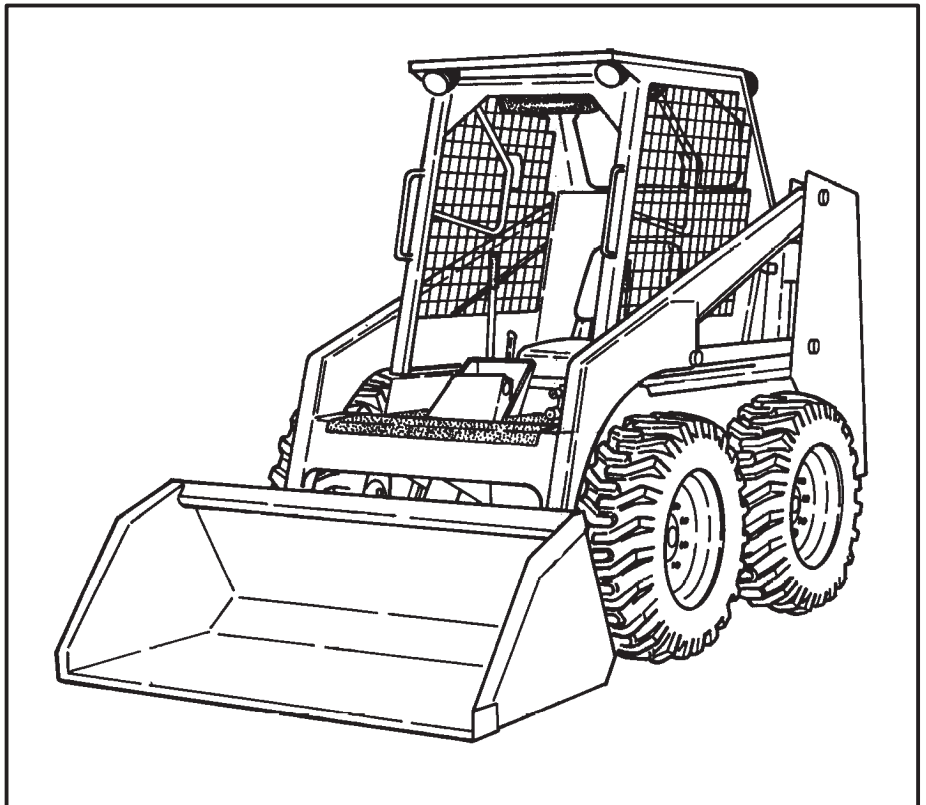

# MAINTENANCE SAFETY



## WARNING

Instructions are necessary before operating or servicing machine. Read and understand the Operation & Maintenance Manual, Operator's Handbook and signs (decals) on machine. Follow warnings and instructions in the manuals when making repairs, adjustments or servicing. Check for correct function after adjustments, repairs or service. Untrained operators and failure to follow instructions can cause injury or death.

W-2003-0903



**Safety Alert Symbol:** This symbol with a warning statement, means: "Warning, be alert! Your safety is involved!" Carefully read the message that follows.

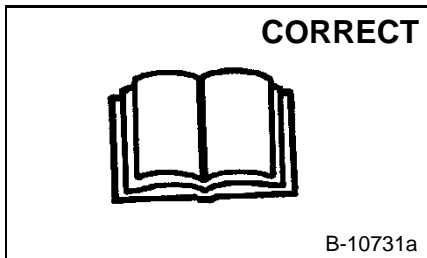

B-10731a

⚠ Never service the Bobcat Skid-Steer Loader without instructions.

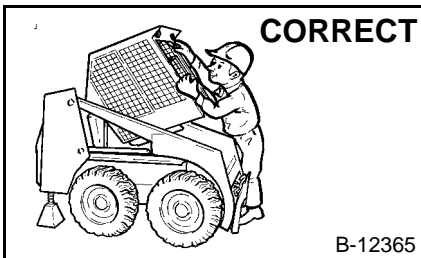

B-12365

⚠ Use the correct procedure to lift or lower operator cab.

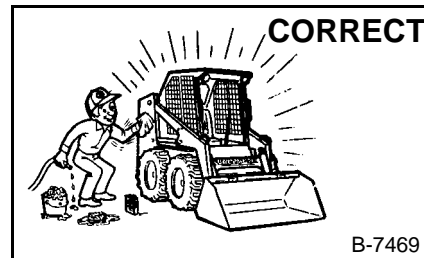

B-7469

⚠ Cleaning and maintenance are required daily.

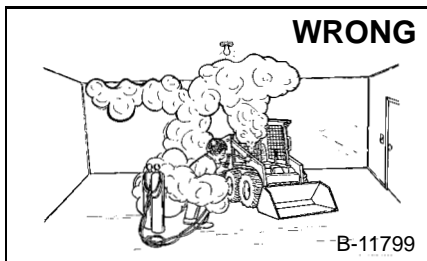

B-11799

- ⚠ Have good ventilation when welding or grinding painted parts.
- ⚠ Wear dust mask when grinding painted parts. Toxic dust and gas can be produced.
- ⚠ Avoid exhaust fume leaks which can kill without warning. Exhaust system must be tightly sealed.

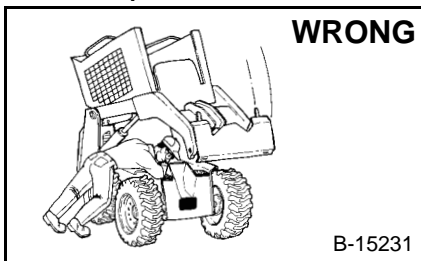

B-15231

⚠ Disconnecting or loosening any hydraulic tubeline, hose, fitting, component or a part failure can cause lift arms to drop. Do not go under lift arms when raised unless supported by an approved lift arm support device. Replace it if damaged.

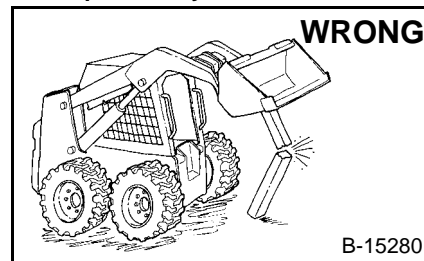

B-15280

- ⚠ Never work on loader with lift arms up unless lift arms are held by an approved lift arm support device. Replace if damaged.
- ⚠ Never modify equipment or add attachments not approved by Bobcat Company.

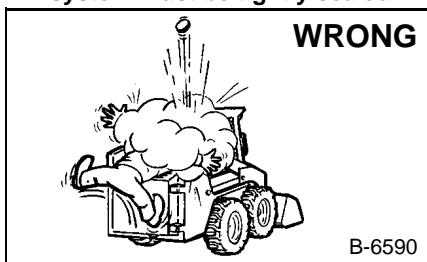

B-6590

- ⚠ Stop, cool and clean engine of flammable materials before checking fluids.
- ⚠ Never service or adjust loader with the engine running unless instructed to do so in the manual.
- ⚠ Avoid contact with leaking hydraulic fluid or diesel fuel under pressure. It can penetrate the skin or eyes.
- ⚠ Never fill fuel tank with engine running, while smoking or when near open flame.

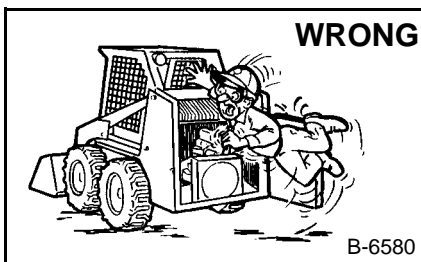

B-6580

- ⚠ Keep body, jewelry and clothing away from moving parts, electrical contact, hot parts and exhaust.
- ⚠ Wear eye protection to guard from battery acid, compressed springs, fluids under pressure and flying debris when engines are running or tools are used. Use eye protection approved for type of welding.
- ⚠ Keep rear door closed except for service. Close and latch door before operating the loader.



B-6589

- ⚠ Lead-acid batteries produce flammable and explosive gases.
- ⚠ Keep arcs, sparks, flames and lighted tobacco away from batteries.
- ⚠ Batteries contain acid which burns eyes or skin on contact. Wear protective clothing. If acid contacts body, flush well with water. For eye contact flush well and get immediate medical attention.

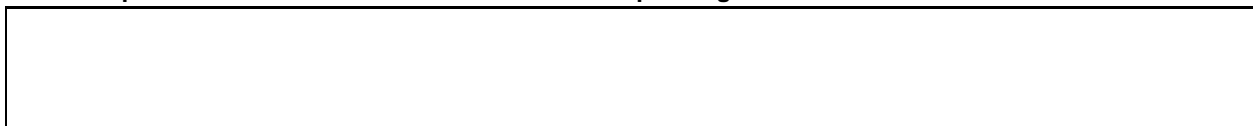

# CONTENTS

FOREWORD .....	iii
SAFETY INSTRUCTIONS .....	v
SERIAL NUMBER LOCATIONS .....	vii
DELIVERY REPORT .....	vii
BOBCAT LOADER IDENTIFICATION .....	viii
PREVENTIVE MAINTENANCE .....	1-1
HYDRAULIC SYSTEM .....	2-1
HYDROSTATIC SYSTEM .....	3-1
DRIVE SYSTEM .....	4-1
MAIN FRAME .....	5-1
ELECTRICAL SYSTEM .....	6-1
ENGINE SERVICE .....	7-1
SPECIFICATIONS .....	8-1

**CALIFORNIA  
PROPOSITION 65 WARNING**  
Diesel engine exhaust and some of its  
constituents are known to the State of California  
to cause cancer, birth defects and other  
reproductive harm.

**PREVENTIVE  
MAINTENANCE**

**HYDRAULIC  
SYSTEM**

**HYDROSTATIC  
SYSTEM**

**DRIVE  
SYSTEM**

**MAIN  
FRAME**

**ELECTRICAL  
SYSTEM**

**ENGINE  
SERVICE**

**SPECIFICATIONS**

# FOREWORD

This manual is for the Bobcat loader mechanic. It provides necessary servicing and adjustment procedures for the Bobcat loader and its component parts and systems. Refer to the Operation & Maintenance Manual for operating instructions, starting procedure, daily checks, etc.

A general inspection of the following items must be made after the loader has had service or repair:

1. Check that the ROPS/FOPS (Including sidescreens) is in good condition and is not modified.

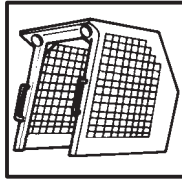

2. Check that ROPS mounting hardware is tightened and is Melroe approved.

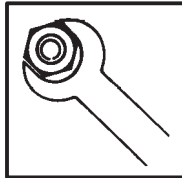

3. The seat belt must be correctly installed, functional and in good condition.

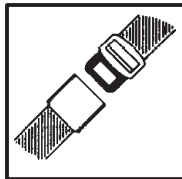

4. The seat bar and pedal interlocks must be correctly adjusted, clean and lubricated.

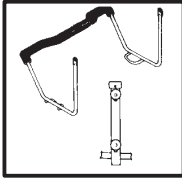

5. Machine signs must be legible and in the correct location.

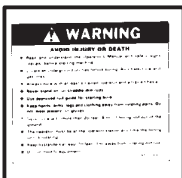

6. Steering levers and foot pedals must return to neutral.

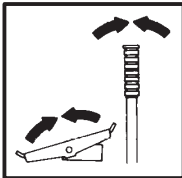

7. Check for correct function of the work lights.



8. The parking brake must function correctly.



9. Enclosure door latches must open and close freely.



10. Bob-Tach wedges and linkages must function correctly and be in good condition.

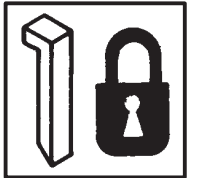

11. Safety treads must in good condition.

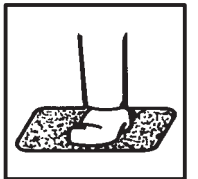

12. Check for correct function of indicator lamps (Optional on some models).

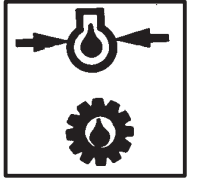

13. Check hydraulic fluid level, engine oil level and fuel supply.

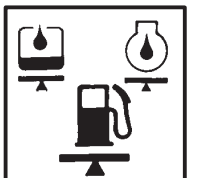

14. Inspect for fuel, oil or hydraulic fluid leaks.

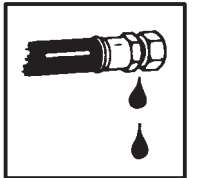

15. Lubricate the loader.



16. Check the condition of the battery and cables.

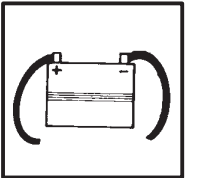

17. Inspect the air cleaner for damage or leaks. Check the condition of the element.

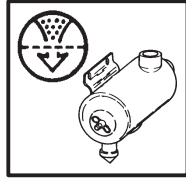

18. Check the electrical charging system.

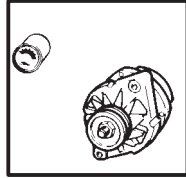

19. Check tires for wear and pressure.

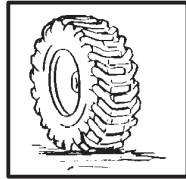

20. Inspect for loose or broken parts or connections.

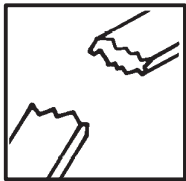

21. Operate the loader and check all functions.

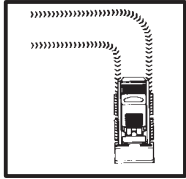

22. Check for any field modification not completed.



23. Check for correct function of the Bobcat Interlock Control System (BICS™) before the machine is returned to the customer.

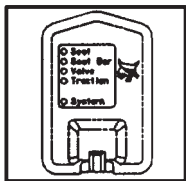

Recommend to the owner that all necessary corrections be made before the machine is returned to service.



## SAFETY INSTRUCTIONS (Cont'd)

- Wear tight fitting clothing. Always wear safety glasses when maintaining or servicing loader. Safety glasses, hearing protection or loader special applications kit are required for some work. See your dealer for Melroe Safety equipment.
- Know where fire extinguisher and first aid kit are located and how to use them.
- Do not use the Bobcat loader where exhaust, arcs, sparks or hot components can contact flammable material, explosive dust or gases.
- The engine compartment and engine cooling system must be inspected every day and cleaned if necessary to prevent fire hazard and overheating.
- Check all electrical wiring and connections for damage. Keep the battery terminals clean and tight. Repair or replace any damaged part.
- Check fuel and hydraulic tubes, hoses and fittings for damage and leakage. Never use open flame or bare skin to check for leaks. Tighten or replace any parts that show leakage. Always clean fluid spills. Do not use gasoline or diesel fuel for cleaning parts. Use commercial nonflammable solvents.
- Follow any environmental safety regulations when disposing of used fluids such as engine oil, grease or anti-freeze.
- Do not use ether or starting fluids on this engine. It has a glow plug. These starting aids can cause explosion and injure you or bystanders.
- Always clean the loader and disconnect the battery before doing any welding. Cover rubber hoses, battery and all other flammable parts. Keep a fire extinguisher near the loader when welding. Have good ventilation when grinding or welding painted parts. Wear dust mask when grinding painted parts. Toxic dust or gas can be produced.
- Stop the engine and let it cool before adding fuel. No smoking!
- Use the procedure in the Operation & Maintenance or Service Manuals for connecting the battery.

A fire extinguisher is available from your local dealer. The fire extinguisher can be installed in the location shown [A].



## SERIAL NUMBER LOCATIONS

Always use the serial number of the loader when requesting service information or when ordering parts. Early or later models (identification made by serial number) may use different parts, or it may be necessary to use a different procedure in doing a specific service operation.

### LOADER SERIAL NUMBER

The loader serial number plate is located on the inside of the left upright, above the grill [A].

Explanation of loader Serial Number:

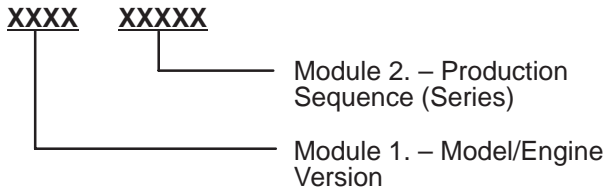

The four digit Model/Engine Combination module number identifies the model number and engine combination. This number (in parenthesis beside the model number) is used in the Service Manual to more easily identify the standard, optional and field accessory equipment included or available for each specific model.

The five digit Production Sequence Number identifies the order which the loader is produced.

### ENGINE SERIAL NUMBER (743B)

The serial number is located at the fuel injection pump side on the engine block [B].

### ENGINE SERIAL NUMBER (742B)

The serial number is located at top left surface of the engine block [C].

### DELIVERY REPORT

The Delivery Report must be filled out by the dealer and signed by the owner or operator when the Bobcat loader is delivered. An explanation of the form must be given to the owner. Make sure it is filled out completely [D].

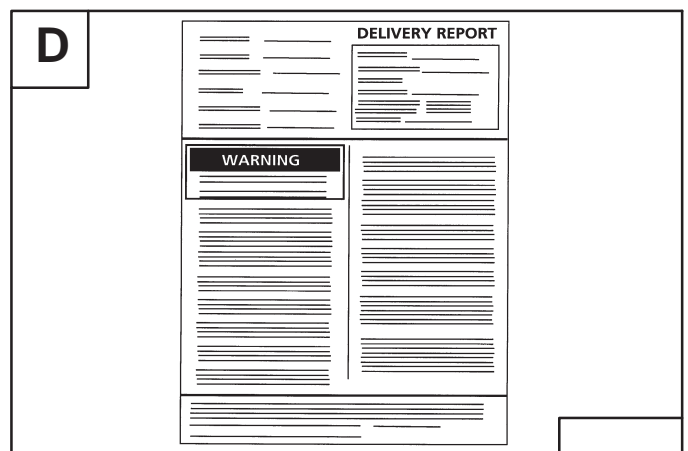
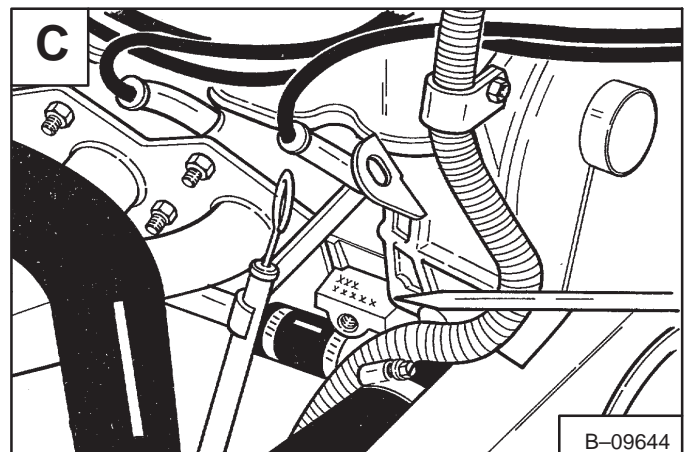
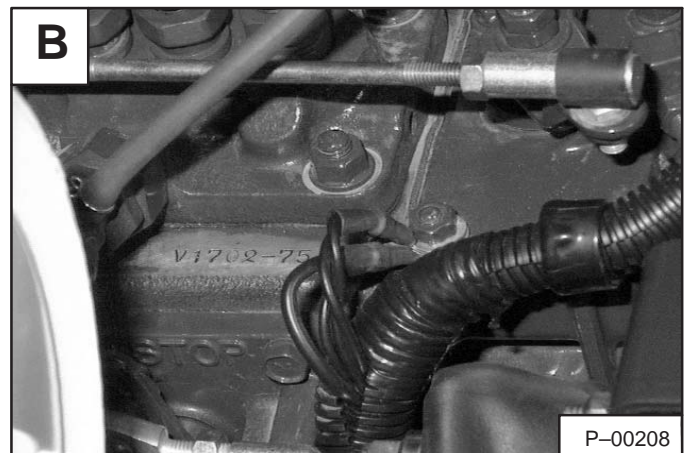

BOBCAT SKID STEER LOADER IDENTIFICATION

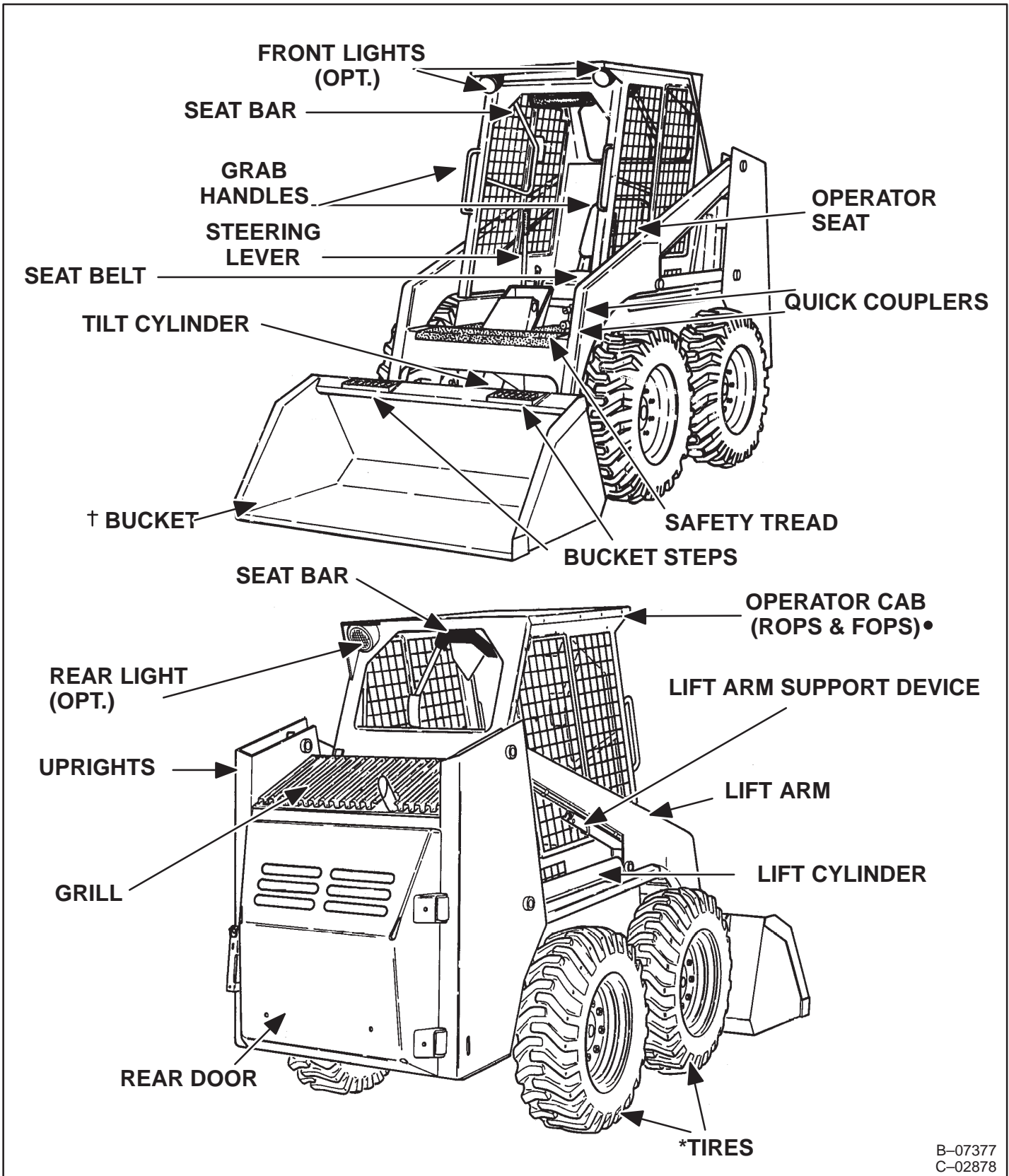

B-07377  
C-02878

\* TIRES – Flotation tires are shown. THE Bobcat loader is base-equipped with standard tires.

† BUCKET – Several different buckets and other attachments are available for the Bobcat loader.

• ROPS, FOPS – Roll-Over Protective Structure, Falling Object Protective Structure, per SE J1040 and SAE J1043. The Bobcat loader is base-equipped with a standard operator cab as shown.



## PREVENTIVE MAINTENANCE

## PREVENTIVE MAINTENANCE

	Page Number
AIR CLEANER SERVICE (743B) Replacement Of The Filter Element .....	1-7
AIR CLEANER SERVICE (742B) Replacement Of The Filter Element .....	1-9
ALTERNATOR BELT ADJUSTMENT (743B) Adjusting The Alternator Belt .....	1-19
ALTERNATOR BELT ADJUSTMENT (742B) Adjusting The Alternator Belt .....	1-20
ENGINE COOLING SYSTEM (743B) Cleaning The Cooling System .....	1-16
Coolant Level .....	1-16
Removing Coolant From The Cooling System .....	1-16
ENGINE COOLING SYSTEM (742B) Cleaning The Cooling System .....	1-18
Coolant Level .....	1-18
Removing Coolant From The Cooling System .....	1-18
ENGINE LUBRICATION SYSTEM (743B) Checking Engine Oil .....	1-13
Replacing Oil And Filter .....	1-13
ENGINE LUBRICATION SYSTEM (742B) Checking Engine Oil .....	1-15
Replacement Of The Oil And Filter .....	1-15
FINAL DRIVE TRANSMISSION (Chaincase) Checking And Adding Oil .....	1-27
FUEL SYSTEM (743B) Filling The Fuel Tank .....	1-10
Fuel Filter .....	1-10
Fuel Specifications .....	1-10
Removing Air From The Fuel System .....	1-11
FUEL SYSTEM (742B) Filling The Fuel Tank .....	1-12
Fuel Filter .....	1-12
Fuel Specifications .....	1-12
GOVERNOR (742B) Governor Adjustment .....	1-21
Governor Belt Adjustment .....	1-21
Governor Oil Level .....	1-21
HYDRAULIC/HYDROSTATIC SYSTEM Checking And Adding Fluid .....	1-23
Hydraulic/Hydrostatic Filter Replacement .....	1-24
Removing The Hydraulic Fluid .....	1-24

## PREVENTIVE MAINTENANCE (Cont'd)

	<b>Page Number</b>
LIFT ARM SUPPORT DEVICE	
To Disengage Lift Arm Support Device .....	1-4
To Engage Lift Arm Support Device .....	1-4
LIFTING AND BLOCKING THE LOADER	
Procedure .....	1-2
LUBRICATING THE BOBCAT LOADER	
Procedure .....	1-28
OPERATOR CAB	
Lowering The Operator Cab .....	1-6
Raising The Operator Cab .....	1-5
PARKING THE LOADER	
Procedure .....	1-3
REMOTE START SWITCH	
Procedure .....	1-30
SEAT BAR RESTRAINT SYSTEM	
Description .....	1-6
Seat Bar Inspection .....	1-6
Seat Bar Maintenance .....	1-6
SERVICE SCHEDULE	
Chart .....	1-1
SPARK ARRESTOR MUFFLER	
Cleaning Procedure .....	1-25
TIRE MAINTENANCE	
Tire Mounting .....	1-26
Tire Rotation .....	1-26
Wheel Nuts .....	1-26
TRANSPORTING THE BOBCAT LOADER	
Procedure .....	1-3
USING A BOOSTER BATTERY (Jump Starting)	
Procedure .....	1-22
U-JOINT LUBRICATION	
Procedure .....	1-30

## SERVICE SCHEDULE

Maintenance work must be done at regular intervals. Failure to do so will result in excessive wear and early failures. The service schedule is a guide for correct maintenance of the Bobcat loader.

### **WARNING**

Instructions are necessary before operating or servicing machine. Read Operation & Maintenance Manual, Handbook and signs (decals) on machine. Follow warnings and instructions in the manuals when making repairs, adjustments or servicing. Check for correct function after adjustments, repairs or service. Failure to follow instructions can cause injury or death.

W-2003-0797

SERVICE SCHEDULE		HOURS					
ITEM	SERVICE REQUIRED	8-10	50	100	250	500	1000
Engine Oil	Check the oil level & add oil as needed.	■					
Engine Air Cleaner	Replace the outer filter element only when the read ring shows in the indicator window. Check for leaks & damaged components.	■					
Engine Cooling System	Clean debris from shrouds & grill. Check coolant level in the recovery tank & add as needed.	■					
Tires	Check for damaged tires & correct air pressure.	■					
Seat Belt, Seat Bar & Pedal Interlocks.	Check the condition of seat belt. Check the seat bar & pedal interlocks for correct operation.	■					
Safety Signs & Safety Tread	Check for damaged signs (decals) & safety treads. Replace any signs or safety treads that are damaged or worn.	■					
Lift Arm, Cyl., Bob-Tach, Pivot Pin	Add grease to the fittings until extra grease shows.	■					
Fuel Filter (743B)	Remove water from filter.	■					
Operator Cab	Check the fastening bolts, washers & nuts. Check the condition of the cab.	■					
Wheel Nuts	<input type="checkbox"/> Check for loose wheel nuts. Tighten to correct torque if loose.		■				
Battery	Check the electrolite level. Check battery cables for corrosion. Check that the battery cables are tight. Check covers.		■				
Hydraulic Fluid, Tubelines & Hoses	Check the fluid level & add as needed. Check for damage & leaks & replace as needed.		■				
Alternator Drive Belt	Check the tension & adjust as needed.		■				
Chaincase	Check the fluid level & add as needed.		■				
Controls & Brake	Check operation & adjust as needed.		■				
Engine Oil & Filter	Replace the oil & the engine oil filter.			■			
Spark Arrestor Muffler	Remove the plug & clean the spark chamber.			■			
Governor Oil Level (742B)	Check level, if low, add oil.			■			
Governor Shaft (742B)	Grease or oil the shaft.				■		
Seat Bar	Grease pivot as needed.				■		
Steering Shaft Pivots	Grease two fittings. Add oil to steering shaft.				■		
Hyd./Hydro. Filters	● Replace filter elements.				■		
U-Joint	Grease three fittings with correct grease.				■		
Fuel Filter	Replace the filter element.				■		
Hyd. Reservoir Breather Cap	Replace breather cap.					■	
Chaincase	Replace the fluid.						■
Hydraulic Reservoir	Replace the hydraulic fluid.						■
Case Drain Filter	† Replace the filter.						■

- Check wheel nut torque every 8 hours for the first 24 hours.
- Also replace hydrostatic filter element when the transmission warning light stays on for five minutes after the hydrostatic fluid is at operating temperature.
- Or every 12 months.
- † Replace case drain filter in the event of any Hydraulic/Hydrostatic System failure.



# WARNING

Instructions are necessary before operating or servicing machine. Read Operation & Maintenance Manual, Handbook and signs (decals) on machine. Follow warnings and instructions in the manuals when making repairs, adjustments or servicing. Check for correct function after adjustments, repairs or service. Failure to follow instructions can cause injury or death [A].

W-2003-0797

## LIFTING AND BLOCKING THE LOADER

### Procedure

Always park the loader on a level surface.



# WARNING

Put jackstands under the front axles and rear corners of the frame before running the engine for service. Failure to use jackstands can allow the machine to fall or move and cause injury or death.

W-2017-0286

Put floor jack under the rear of the loader [B].

Lift the rear of the loader and install jackstands [B].

Put the floor jack under the front the loader [C].

Lift the front of the loader and put jackstands [C].

**NOTE:** Make sure the jackstands do not touch the tires.

A



B-07023

B

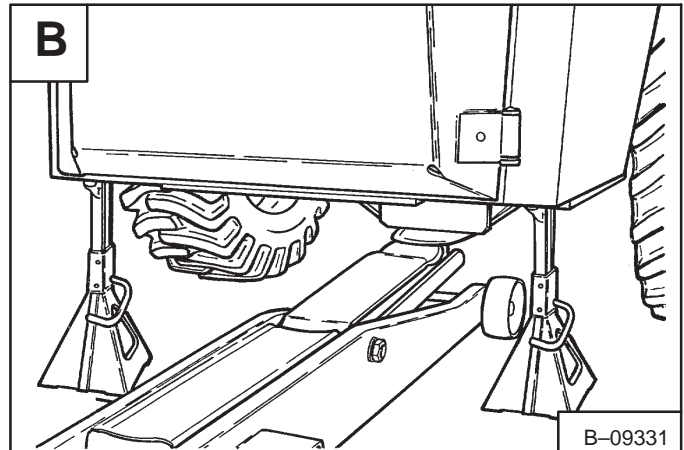

B-09331

C

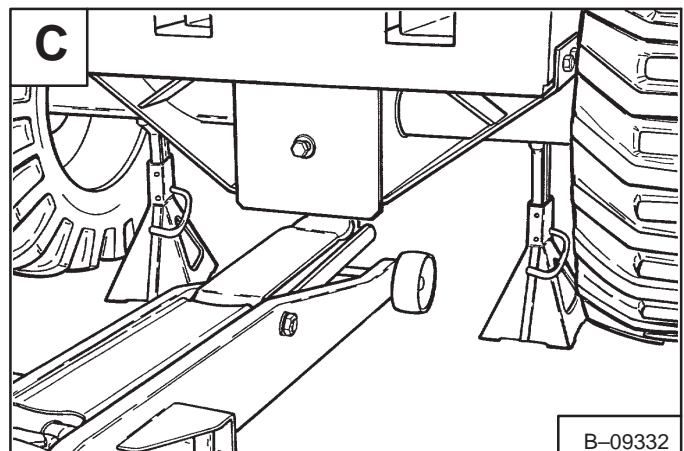

B-09332

## PARKING THE BOBCAT LOADER

### Procedure

Stop the Bobcat loader on level ground.

Lower the lift arms fully and put the edge of the bucket on the ground.

Pull the throttle all the way backward. Turn the key switch to the OFF position.



## WARNING

### AVOID INJURY OR DEATH

Before you leave the operator's seat:

- Lower the lift arms, put the attachment flat on the ground.
- Stop the engine.
- Engage the parking brake.
- Raise seat bar, move pedals until both lock.

W-2045-1086

Engage the parking brake.

Lift the seat bar and make sure the foot pedals are in the locked position.

Un-buckle the seat belt. Remove the key from the switch to prevent operation of the loader by unauthorized personnel.

## TRANSPORTING THE BOBCAT LOADER



## WARNING

Adequately designed ramps of sufficient strength are needed to support the weight of the machine when loading onto a transport vehicle. Wood ramps can break and cause personal injury.

W-2058-0494

A loader with an empty bucket or no attachment must be loaded backward onto the transport vehicle [A].

The rear of the trailer must be blocked or supported [A] when loading or unloading the loader to prevent the front end of the trailer from raising up.

Use the following procedure to fasten the Bobcat loader to the transport vehicle to prevent the loader from moving during sudden stops or when going up and down slopes [B].

Lower the bucket or attachment to the floor. Stop the engine. Engage the parking brake. Install chains at the front and rear of the loader as shown in figure [B].

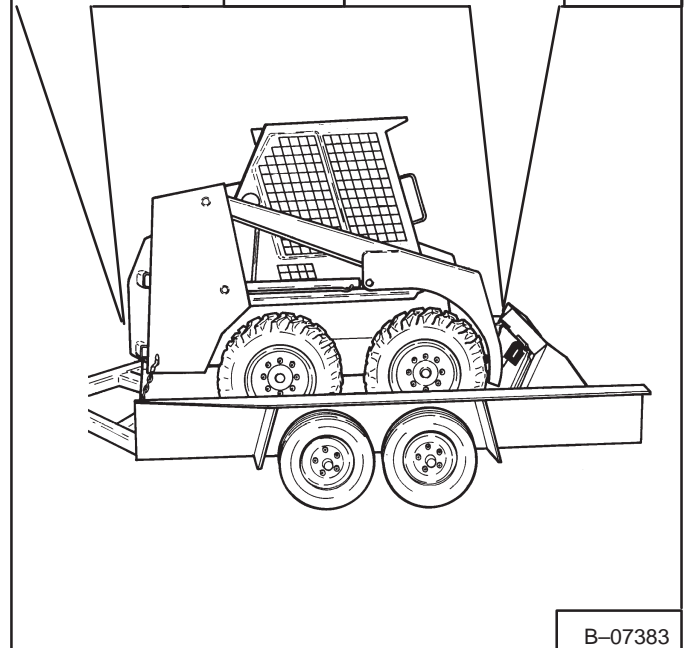
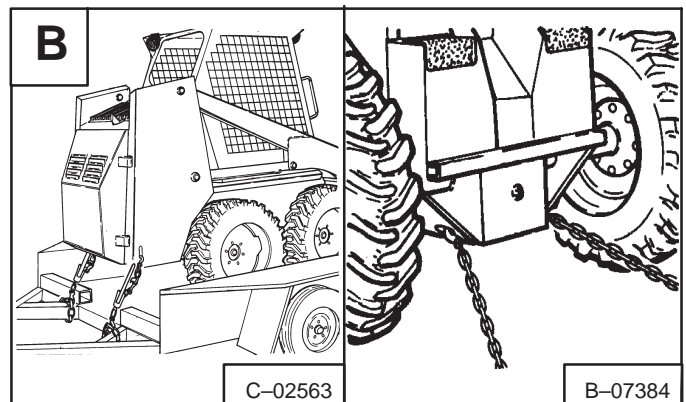
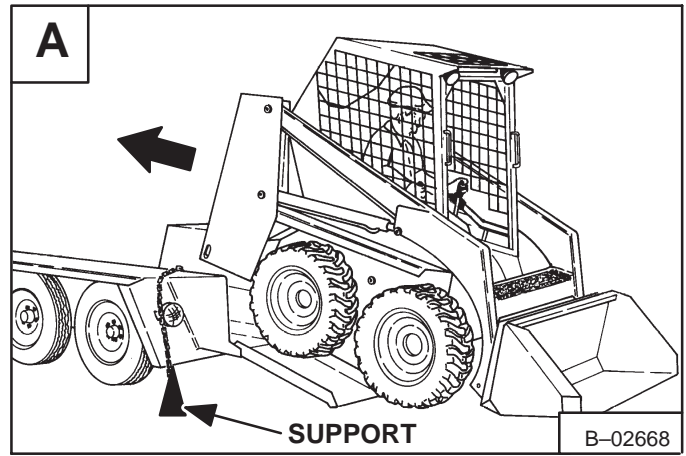

## LIFT ARM SUPPORT DEVICE



# WARNING

Never work on a machine with the lift arms up unless the lift arms are secured by a lift arm support device. Failure to use an approved lift arm support device can allow the lift arms or attachment to fall and cause injury or death.

W-2059-0991

### To Engage Lift Arm Support Device

Maintenance and service work can be done with lift arms lowered. If the lift arms are raised, use the following procedure:

Put jackstands under the rear corners of the loader.

Disconnect the spring from the lift arm support device retaining pin, hold onto the support device and remove the retaining pin [A].

Lower the lift arm support device on top of the lift cylinder. Hook the free end of the spring to the lift arm support device so there will be no interference with the support device engagement [B].

With the operator in the seat, seat belt fastened and seat bar lowered, start the engine.

Raise the lift arms, until the lift arm support device is on the lift cylinder rod [C].

Lower the lift arms slowly until the support device is held between the lift arm and the lift cylinder. Stop the engine. Raise the seat bar and move pedals until both pedals lock.

Install pin into the rear of the lift arm support device below the cylinder rod.

### To Disengage Lift Arm Support Device

Remove the pin from the lift arm support device.

Connect the spring from the lift arm support device to the bracket below the lift arms [D].

With the operator in the seat, seat belt fastened and seat bar lowered, start the engine.

Raise the lift arms a small amount and the spring will lift the support device off the lift cylinder rod. Lower the lift arms. Stop the engine.

Raise the seat bar and move pedals until both pedals lock.

Disconnect the spring from the bracket.

Raise the support device into storage position and insert pin through lift arm support device and bracket [A].

Connect spring to pin.

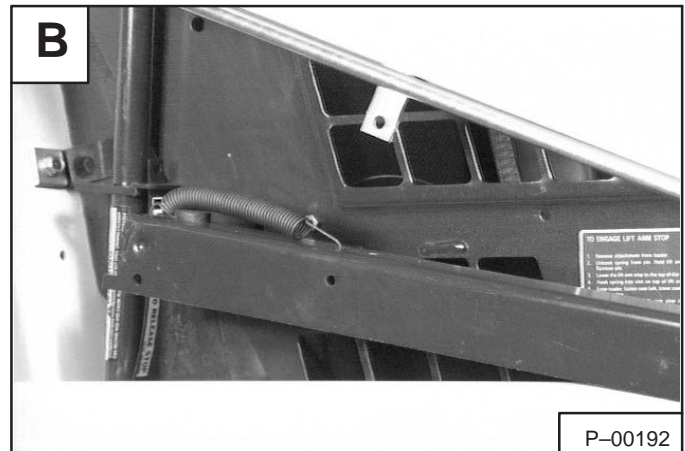

## OPERATOR CAB

The Bobcat loader has an operator cab (ROPS and FOPS) as standard equipment to protect the operator from rollover and falling objects. Check with your dealer if the operator cab has been damaged.

### **WARNING**

Never modify operator cab by welding, grinding, drilling holes or adding attachments unless instructed to do so by Melroe Company. Changes to the cab can cause loss of operator protection from rollover and falling objects, and result in injury or death.

W-2069-1285

### Raising The Operator Cab

Stop the loader on a level surface. Lower the lift arms. If the lift arms must be up while raising the operator cab, install the lift arm support device. (See Page 1-4.)

### **WARNING**

Before the cab or the lift arms are raised for service, jackstands must be put under the rear corners of the frame. Failure to use jackstands can allow the machine to tip backward causing injury or death.

W-2014-0895

Loosen the nut (both sides) at the corner of the operator cab [A].

Remove the nut and plate (both sides) [B].

Remove the bolt and washer (both sides) [B].

Lift on the grab handle and bottom of the operator cab slowly until the cab latching mechanism engages and the cab is all the way up [C].

### Lowering The Operator Cab

Pull down on the bottom of the operator cab until it stops at the latching mechanism. Release the latching mechanism and pull the cab all the way down [D].

Install bolt and washer from underneath the fender.

Install the plate and nut [B].

Tighten the nuts to 40-50 ft.-lbs. (54-68 Nm) torque [A].

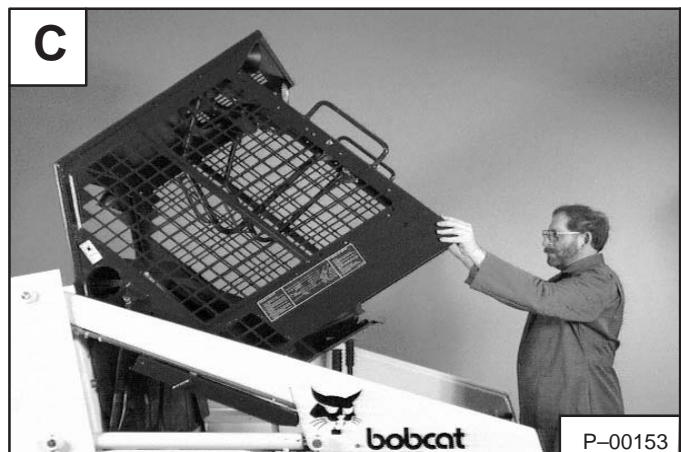
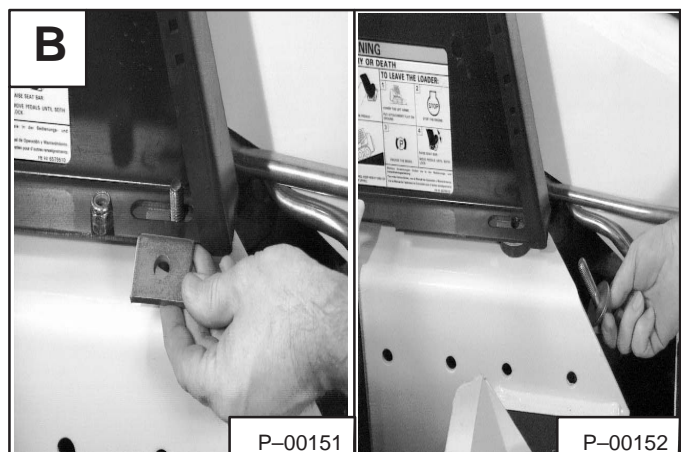
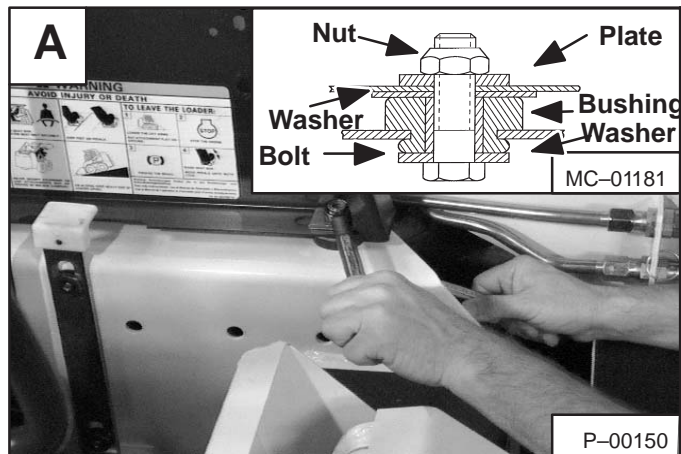

## SEAT BAR RESTRAINT SYSTEM

### Description

The seat bar restraint system has a pivoting seat bar with arm rests and has spring loaded interlocks for the lift and tilt control pedals. The operator controls the use of the seat bar. The seat bar in the down position helps to keep the operator in the seat. The interlocks require the operator to lower the seat bar in order to operate the foot pedal controls. When the seat bar is up, the lift and tilt pedals are locked when returned to the neutral position.

! **WARNING**

**AVOID INJURY OR DEATH**

The seat bar system must lock the lift and tilt control pedals in neutral when the seat bar is up. Service the system if pedals do not lock correctly.

W-2105-1285

### Seat Bar Inspection

Sit in the seat and fasten the seat belt. Engage the parking brake. Pull the seat bar all the way down. Start the engine. Operate each foot pedal to check both the lift and tilt functions. Raise the lift arms until the bucket is about 2 feet (600 mm) off the ground.

Raise the seat bar. Try to move each foot pedal. Pedals must be firmly locked in neutral position. There must be no motion of the lift arms or tilt (bucket) when the pedals are pushed.

Pull the seat bar down, lower the lift arms. Operate the lift pedals. While the lift arms are going up, raise the seat bar and the lift arms should stop.

Lower the seat bar, lower the lift arms and place the bucket flat on the ground. Stop the engine. Raise the seat bar and operate the foot pedals to be sure that the pedals are firmly locked in the neutral position. Unbuckle the seat belt.

### Seat Bar Maintenance

Clean any debris or dirt from the moving parts **[A]** & **[B]**. Inspect the linkage bolts and nuts for tightness. The correct torque is 25–28 ft.-lbs. (34–38 Nm).

Use a general purpose grease to lubricate the seat bar pivot points at each side of the cab **[A]**. If the seat bar system does not function correctly, check for free movement of each linkage part. Check for excessive wear. Adjust pedal control linkage. Replace parts that are worn or damaged. Use only genuine Melroe replacement parts.

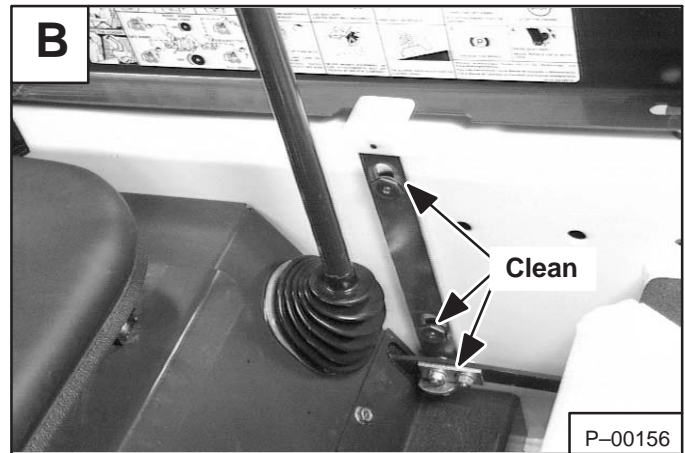
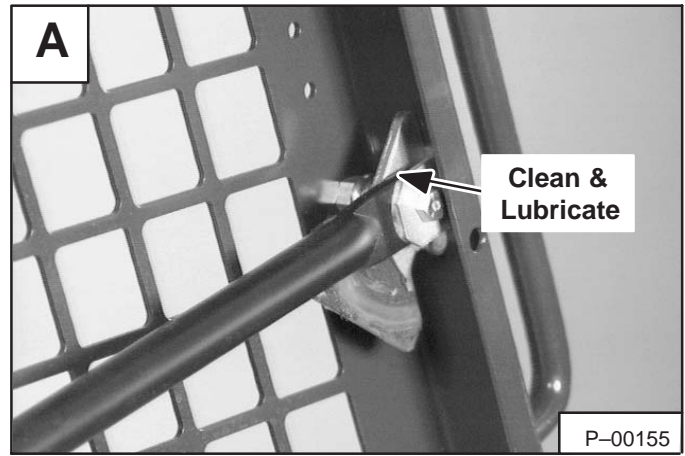



## AIR CLEANER SERVICE (743B)

### Replacement Of The Filter Element

See the *SERVICE SCHEDULE* Page 1-1 for the interval to service the air cleaner system.

Check the air intake hose for damage. Check the air cleaner housing for damage. Check to make sure all connections are tight.

Replace the large (outer) filter element only when the red ring shows in the window of the condition indicator (Item 1) [A].

**NOTE:** Push the button on the condition indicator (see Inset) and start the engine. If the red ring does not show, do not replace the filter element [A].

Service the air cleaner as follows:

Remove the dust cover wing nut [B].

Remove the dust cover [C].

Remove the wing nut at the large air filter element [D].

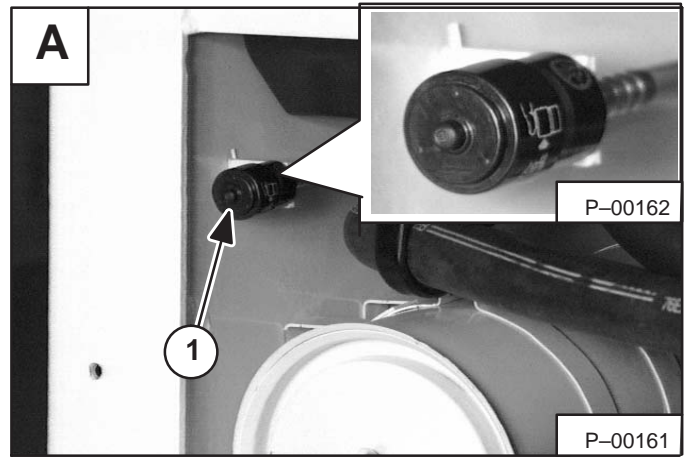

## AIR CLEANER SERVICE (743B) (Cont'd)

### Replacement Of The Filter Element (Cont'd)

Remove the large filter element.

**NOTE: Make sure all sealing surfaces are free of dirt and debris.**

Install the new filter element and tighten the wing nut. Install the dust cover and tighten the wing nut.

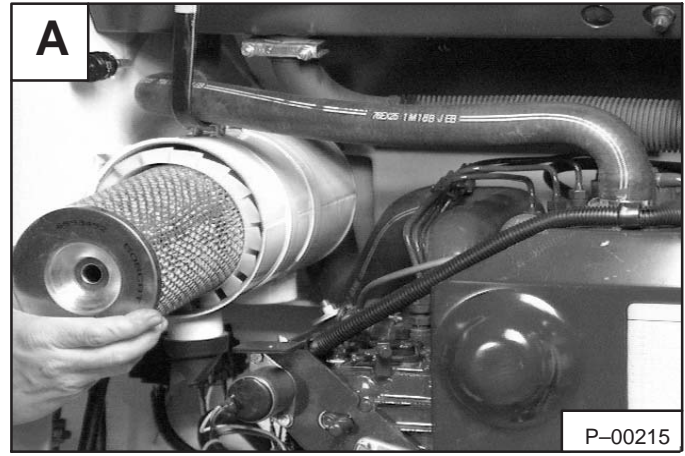

Only replace the inner filter element under the following conditions **[B]**.

Replace the inner filter element every third time the outer filter is replaced.

Replace the inner filter element when the red ring still shows in the condition indicator window after the outer filter is replaced.

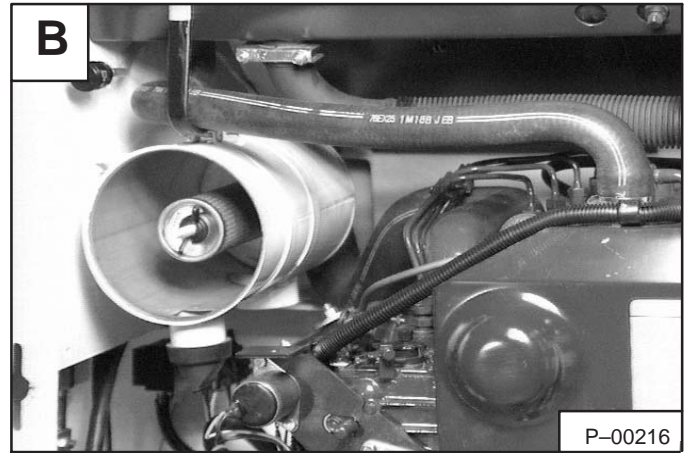

Record the operating hours of the loader on the decal (Item 1) **[C]** inside the rear door.

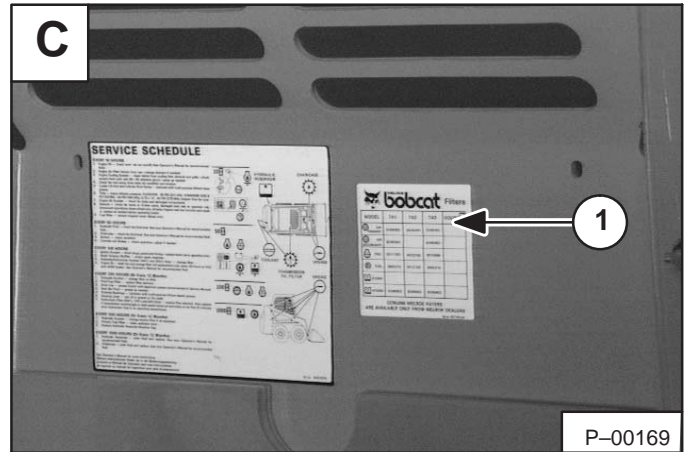

## AIR CLEANER SERVICE (742B)

### Replacement Of The Filter Element

See the *SERVICE SCHEDULE* Page 1-1 for the interval to service the air cleaner system

Check the air intake hose for damage. Check the air cleaner housing for damage. Check to make sure all connections are tight.

Service the air cleaner as follows:

**NOTE:** Before replacing the filter element, push the button on the condition indicator (Inset) and, start the engine [A]. If the red ring does not show, do not replace the filter element.

Loosen the clamp on the dust cup [A].

Remove the dust cup [B].

Remove the wing nut [C].

Remove the element [D].

Check the air cleaner housing for holes or corrosion.

Install the new filter element.

Install the dust cup so the arrow on the cup is up. Tighten the clamp.

All the hoses and clamps must be tight.

Push the button on the condition indicator to remove the red ring.

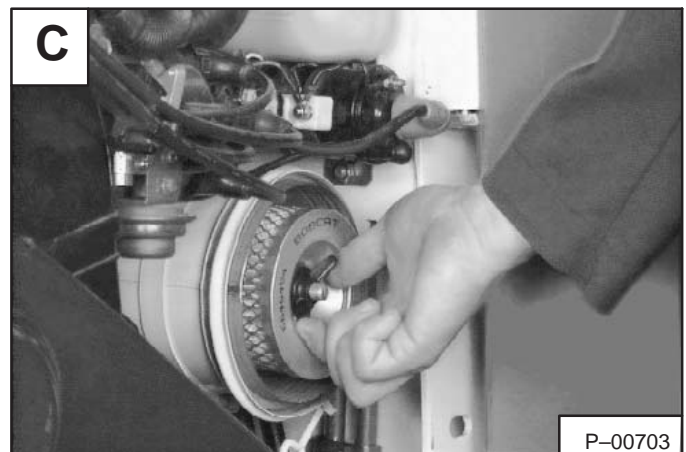
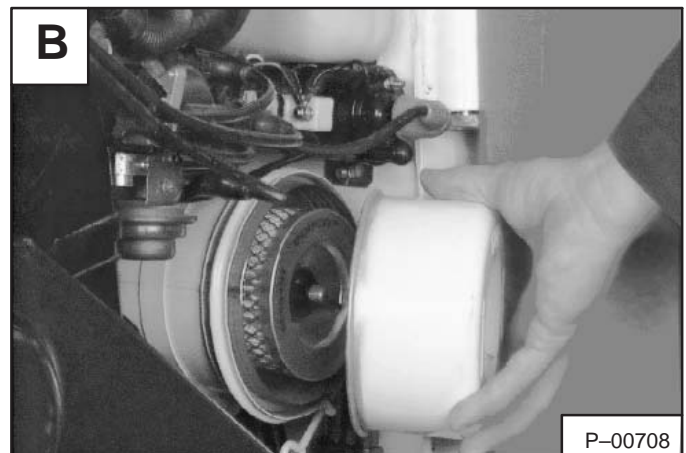
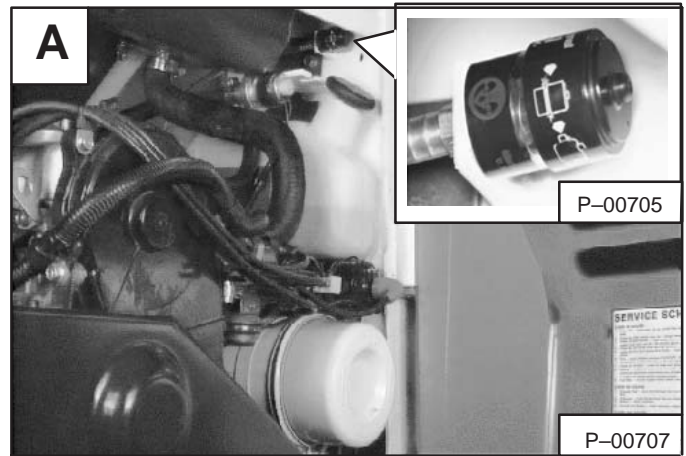

## FUEL SYSTEM (743B)

### Fuel Specifications

Use only clean, high quality fuel. Use Grade No. 2 fuel above 40°F. (4°C.). Use Grade No. 1 fuel at temperatures below 40°F. (4°C.).

### Filling The Fuel Tank

# ! WARNING

Stop and cool the engine before adding fuel. **NO SMOKING!** Failure to obey warnings can cause an explosion or fire.

W-2063-0887

Remove the fuel fill cap [A].

Use a clean, approved safety container to add fuel of the correct specifications. Add fuel only in an area that has free movement of air and no open flames or sparks. **NO SMOKING [B].**

Install and tighten the fuel fill cap [A].

### Fuel Filter

# ! WARNING

Always clean up spilled fuel or oil. Keep heat, flames, sparks or lighted tobacco away from fuel and oil. Failure to use care around combustibles can cause explosion or fire which can result in injury or death.

W-2103-1285

See the *SERVICE SCHEDULE* Page 1-1 for the service interval when to remove the water from the fuel filter.

Turn the fuel shut-off valve clockwise to shut-off the fuel supply [C].

Loosen the drain at the bottom of the filter element (Item 1) [D] to drain the water from the filter [D].

Open the shut-off valve [C].

See the *SERVICE SCHEDULE* Page 1-1 for the service interval when to replace the fuel filter.

Clean the area around the fuel filter. Close the shut-off valve [C].

Use a wrench to loosen the fuel filter bolt (Item 2) [D].

Remove the water trap and fuel filter (Item 3) [D].

Replace the seals as needed.

Install the new filter element and water trap.

Tighten the fuel filter bolt.

Open the shut-off valve [C].

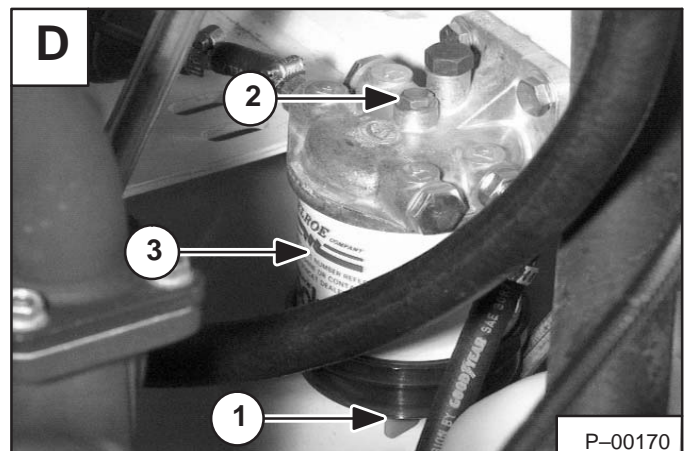
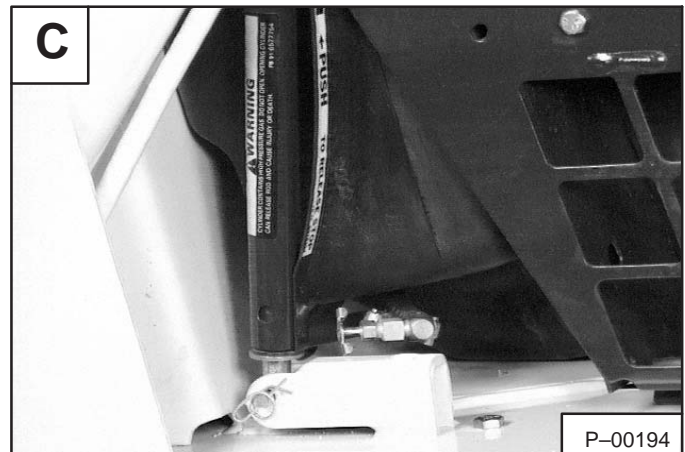

## FUEL SYSTEM (743B) (Cont'd)

### Removing Air From The Fuel System

After replacing the fuel filter element or when the fuel tank has run out of fuel, the air must be removed from the fuel system before starting the engine.

Open the rear door. The engine must be cool.

Open the vent plug (Item 1) [A].

Operate the hand pump (Item 2) [A] until fuel flows from the vent plug with no air bubbles.

Tighten the vent plug.

Operate the hand pump until it feels solid.

Move the engine speed control to minimum RPM. Open the valve (Item 1) [B] and squeeze the hand pump several times.

Start the engine. When the engine runs smoothly, close the valve (Item 1) [B].

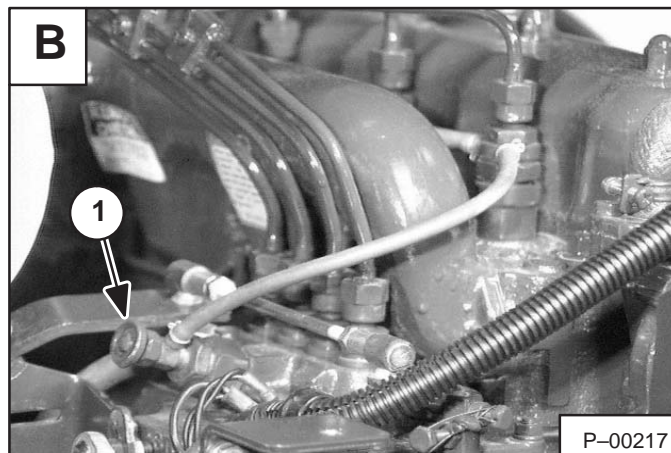
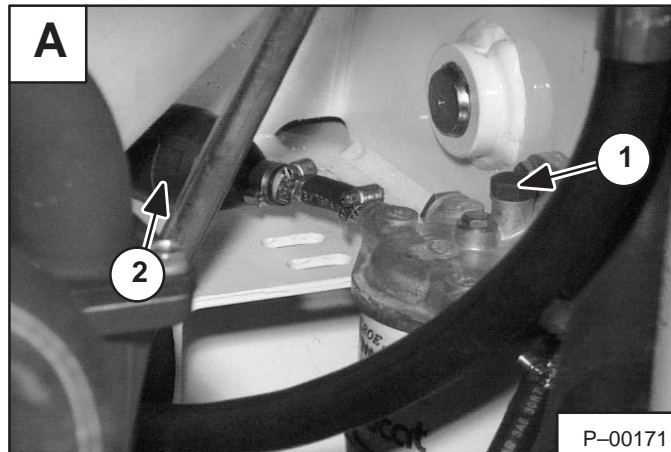

## WARNING

Always clean up spilled fuel or oil. Keep heat, flames, sparks or lighted tobacco away from fuel and oil. Failure to use care around combustibles can cause explosion or fire which can result in injury or death.

W-2103-1285

## FUEL SYSTEM (742B)

### Fuel Specifications

Use leaded or unleaded gasoline in the engine.



## WARNING

Stop and cool the engine before adding fuel.  
**NO SMOKING!** Failure to obey warnings can cause an explosion or fire.

W-2063-0887

### Filling The Fuel Tank

Remove the filler cap [A].

Use a clean, approved safety container to add fuel.

The key switch must be in the OFF position and the engine cool.

Add fuel only in an area that has free movement of air and no open flames or sparks. **NO SMOKING [B].**

After the fuel has been added install the filler cap and tighten.

### Fuel Filter

See the *SERVICE SCHEDULE* Page 1-1 for the interval to service the fuel filter.

Close the valve on the fuel line (Item 1) [C].

Remove the filter element. Install the new filter element. All connections must be tight.

Open the valve at the fuel tank [C].



## WARNING

Always clean up spilled fuel or oil. Keep heat, flames, sparks or lighted tobacco away from fuel and oil. Failure to use care around combustibles can cause explosion or fire which can result in injury or death.

W-2103-1285

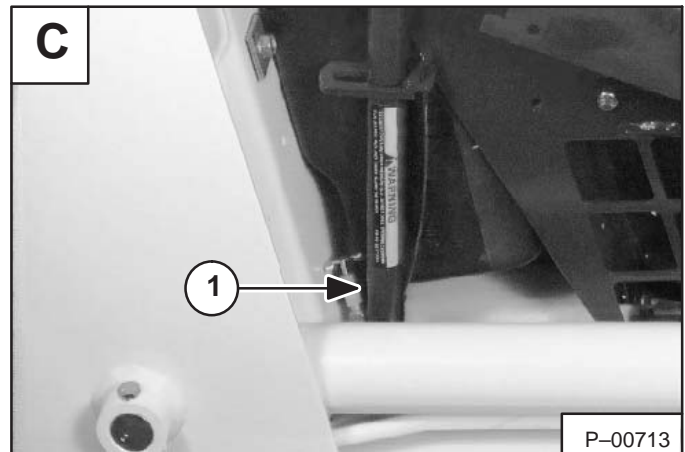
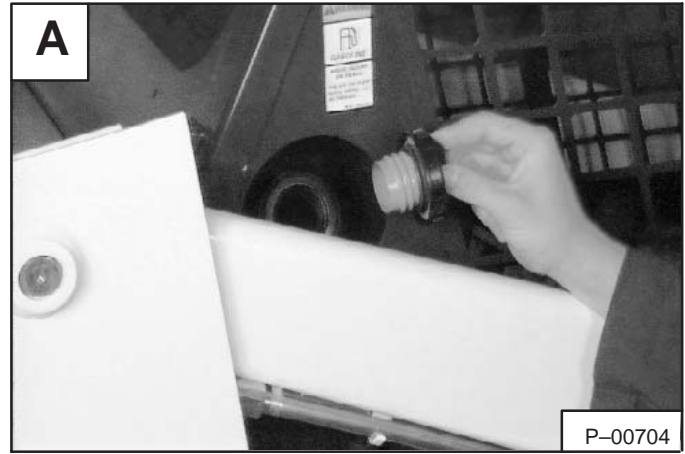

## ENGINE LUBRICATION SYSTEM 743B)

### Checking Engine Oil

Check the oil level every day.

Stop the engine and remove the dipstick [A].

Keep the oil level between the marks on the dipstick.

Use a good quality motor oil that meets API Service Classification of CC, CD or CE. (See Oil Chart.)

### Replacing Oil And Filter

See the *SERVICE SCHEDULE* Page 1-1 for the service interval for replacing the engine oil and filter.

Use the following procedure to replace the oil and filter:

Run the engine until it is at operating temperature. Stop the engine.

Open the rear door and remove the cap from the end of the hose and drain the oil into a container [B].

Remove the filter [C].

Clean the filter housing surface. Put clean oil on the gasket of the new filter install the filter and tighten hand tight.

Remove the oil filler cap [D].

Use a good quality motor oil that meets API Service Classification of CC, CD or CE. (See Oil Chart.)

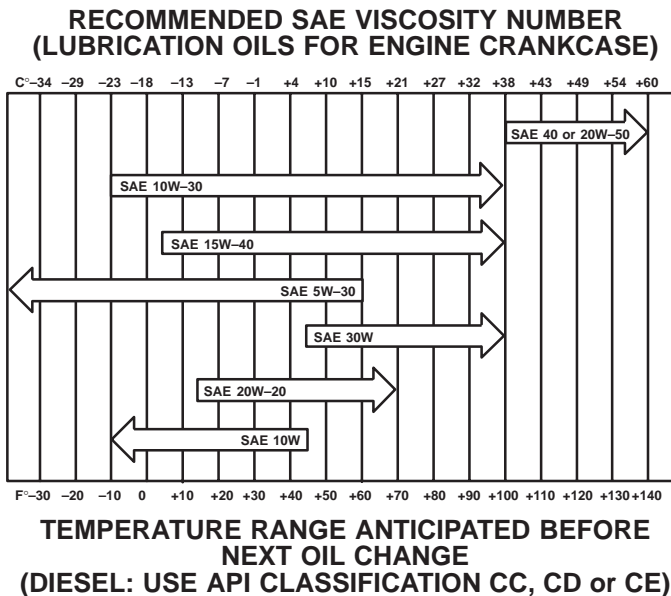
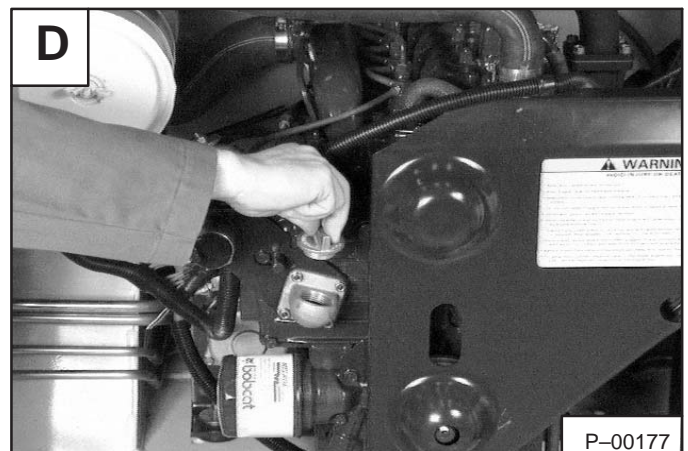
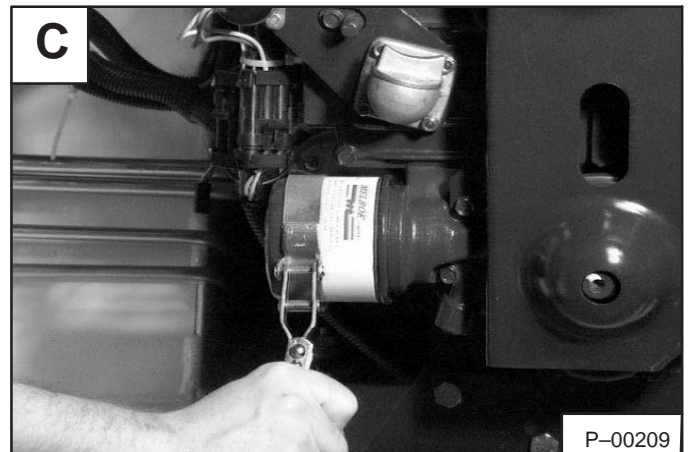
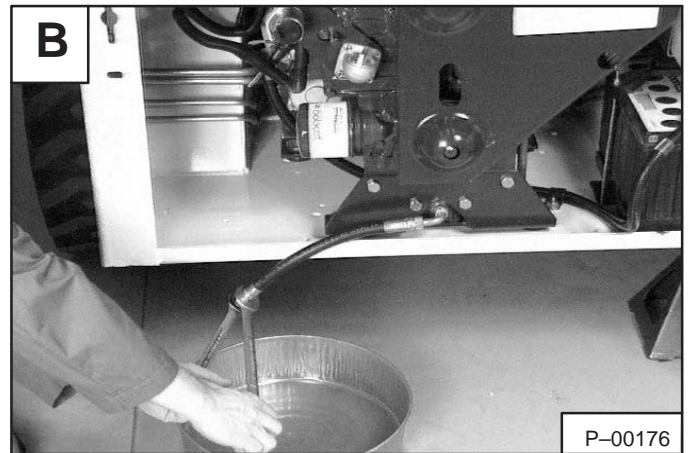
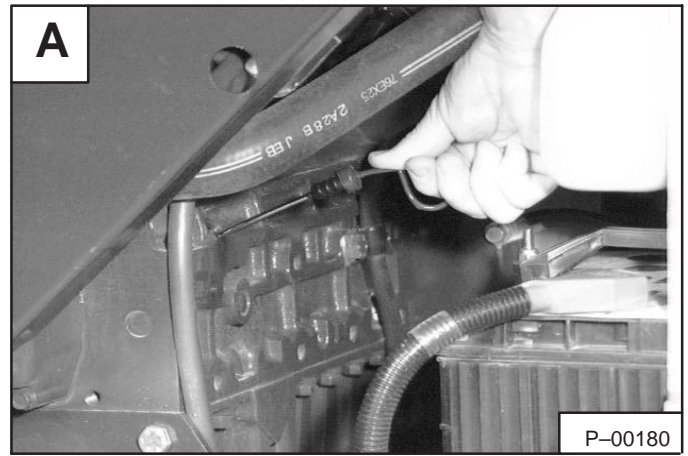

## ENGINE LUBRICATION SYSTEM (743B) (Cont'd)

### Replacing Oil And Filter (Cont'd)

Fill to capacity [A]. (See *SPECIFICATION* Section 8.)

Start the engine and let it run for about 5 minutes. Check for leaks at the filter. Check the oil level. Add oil until the level is at the FULL mark on the dipstick. Install the oil filler cap

**NOTE: DO NOT overfill the crankcase.**

Record the operating hours of the loader on the decal inside the rear door [B].

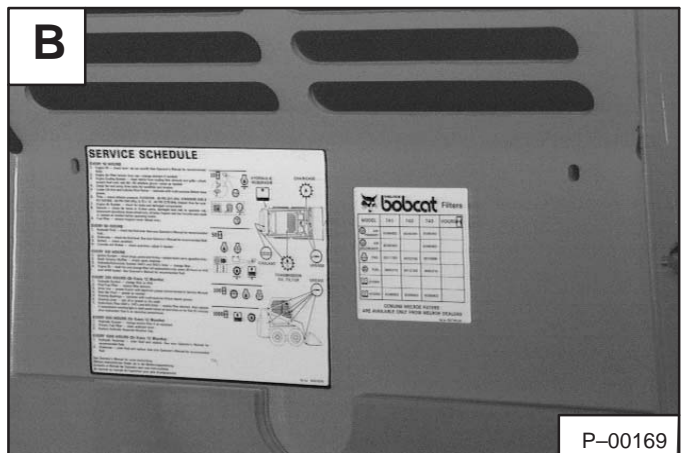
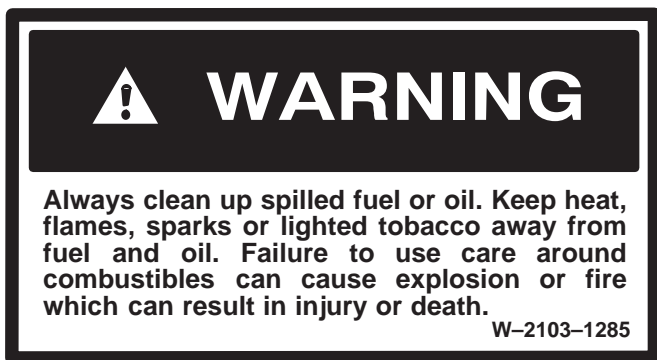





**Download the full PDF manual instantly.**

**Our customer service e-mail:**

**[aservicemanualpdf@yahoo.com](mailto:aservicemanualpdf@yahoo.com)**