

MODEL APPLICATION

Year	Model	Beginning Frame No.
2004	VN2000-A1	JKBVNMA1□4A000001 or JKBVNW00AAA000001 or VNW00A-000001

□:This digit in the frame number changes from one machine to another.



KAWASAKI HEAVY INDUSTRIES, LTD.
Consumer Products & Machinery Company

Part No.99924-1320-02

Printed in Japan



VULCAN 2000

VN2000



Motorcycle Service Manual

Quick Reference Guide

General Information	1
Periodic Maintenance	2
Fuel System (DFI)	3
Cooling System	4
Engine Top End	5
Clutch	6
Engine Lubrication System	7
Engine Removal/Installation	8
Crankshaft/Transmission	9
Wheels/Tires	10
Final Drive	11
Brakes	12
Suspension	13
Steering	14
Frame	15
Electrical System	16
Appendix	17

LIST OF ABBREVIATIONS

A	ampere(s)	lb	pound(s)
ABDC	after bottom dead center	m	meter(s)
AC	alternating current	min	minute(s)
ATDC	after top dead center	N	newton(s)
BBDC	before bottom dead center	Pa	pascal(s)
BDC	bottom dead center	PS	horsepower
BTDC	before top dead center	psi	pound(s) per square inch
°C	degree(s) Celsius	r	revolution
DC	direct current	r/min, rpm	revolution(s) per minute
F	farad(s)	TDC	top dead center
°F	degree(s) Fahrenheit	TIR	total indicator reading
ft	foot, feet	V	volt(s)
g	gram(s) (mass)	W	watt(s)
h	hour(s)	Ω	ohm(s)
kg	(mass)		
kgf	(force)		
L	liter(s)		

Read OWNER'S MANUAL before operating.

Foreword

This manual is designed primarily for use by trained mechanics in a properly equipped shop. However, it contains enough detail and basic information to make it useful to the owner who desires to perform his own basic maintenance and repair work. A basic knowledge of mechanics, the proper use of tools, and workshop procedures must be understood in order to carry out maintenance and repair satisfactorily. Whenever the owner has insufficient experience or doubts his ability to do the work, all adjustments, maintenance, and repair should be carried out only by qualified mechanics.

In order to perform the work efficiently and to avoid costly mistakes, read the text, thoroughly familiarize yourself with the procedures before starting work, and then do the work carefully in a clean area. Whenever special tools or equipment are specified, do not use makeshift tools or equipment. Precision measurements can only be made if the proper instruments are used, and the use of substitute tools may adversely affect safe operation.

For the duration of the warranty period, we recommend that all repairs and scheduled maintenance be performed in accordance with this service manual. Any owner maintenance or repair procedure not performed in accordance with this manual may void the warranty.

To get the longest life out of your vehicle:

- Follow the Periodic Maintenance Chart in the Service Manual.
- Be alert for problems and non-scheduled maintenance.
- Use proper tools and genuine Kawasaki Motorcycle parts. Special tools, gauges, and testers that are necessary when servicing Kawasaki motorcycles are introduced by the Special Tool Catalog or Manual. Genuine parts provided as spare parts are listed in the Parts Catalog.
- Follow the procedures in this manual carefully. Don't take shortcuts.
- Remember to keep complete records of maintenance and repair with dates and any new parts installed.

How to Use This Manual

In preparing this manual, we divided the product into its major systems. These systems became the manual's chapters. All information for a particular system from adjustment through disassembly and inspection is located in a single chapter.

The Quick Reference Guide shows you all of the product's system and assists in locating their chapters. Each chapter in turn has its own comprehensive Table of Contents.

The Periodic Maintenance Chart is located in the Periodic Maintenance chapter. The chart gives a time schedule for required maintenance operations.

If you want spark plug information, for example, go to the Periodic Maintenance Chart first. The chart tells you how frequently to clean and gap the plug. Next, use the Quick Reference Guide to locate the Periodic Maintenance chapter. Then, use the Table of Contents on the first page of the chapter to find the Spark Plug section.

Whenever you see these WARNING and CAUTION symbols, heed their instructions! Always follow safe operating and maintenance practices.

WARNING

This warning symbol identifies special instructions or procedures which, if not correctly followed, could result in personal injury, or loss of life.

CAUTION

This caution symbol identifies special instructions or procedures which, if not strictly observed, could result in damage to or destruction of equipment.

This manual contains four more symbols (in addition to WARNING and CAUTION) which will help you distinguish different types of information.

NOTE

○ *This note symbol indicates points of particular interest for more efficient and convenient operation.*

● Indicates a procedural step or work to be done.

○ Indicates a procedural sub-step or how to do the work of the procedural step it follows. It also precedes the text of a NOTE.

★ Indicates a conditional step or what action to take based on the results of the test or inspection in the procedural step or sub-step it follows.

In most chapters an exploded view illustration of the system components follows the Table of Contents. In these illustrations you will find the instructions indicating which parts require specified tightening torque, oil, grease or a locking agent during assembly.

General Information



Table of Contents

Before Servicing	1-2
Model Identification.....	1-7
General Specifications.....	1-9
Technical Information – Oxygen Sensor.....	1-11
Technical Information – Electric Solenoid Operated Decompressor	1-16
Technical Information – Dual Balancer Shaft System.....	1-17
Unit Conversion Table	1-19

1-2 GENERAL INFORMATION

Before Servicing

Before starting to perform an inspection service or carry out a disassembly and reassembly operation on a motorcycle, read the precautions given below. To facilitate actual operations, notes, illustrations, photographs, cautions, and detailed descriptions have been included in each chapter wherever necessary. This section explains the items that require particular attention during the removal and reinstallation or disassembly and reassembly of general parts.

Especially note the following:

Battery Ground

Before completing any service on the motorcycle, disconnect the battery wires from the battery to prevent the engine from accidentally turning over. Disconnect the ground wire (-) first and then the positive (+). When completed with the service, first connect the positive (+) wire to the positive (+) terminal of the battery then the negative (-) wire to the negative terminal.

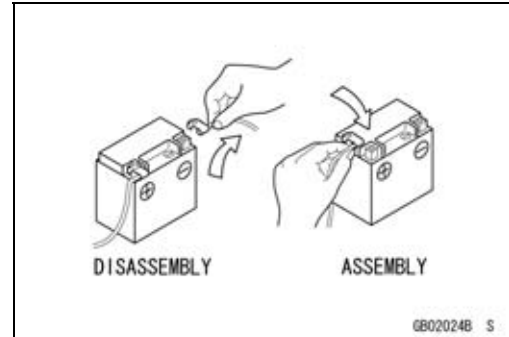

Edges of Parts

Lift large or heavy parts wearing gloves to prevent injury from possible sharp edges on the parts.

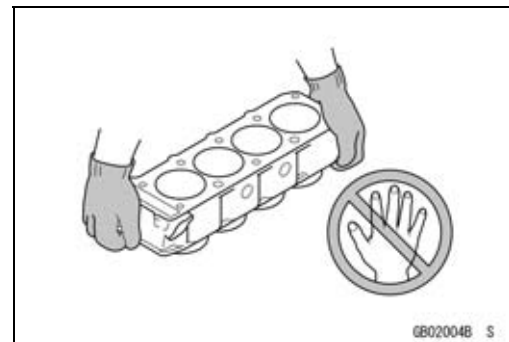

Solvent

Use a high flash point solvent when cleaning parts. High flash point solvent should be used according to directions of the solvent manufacturer.

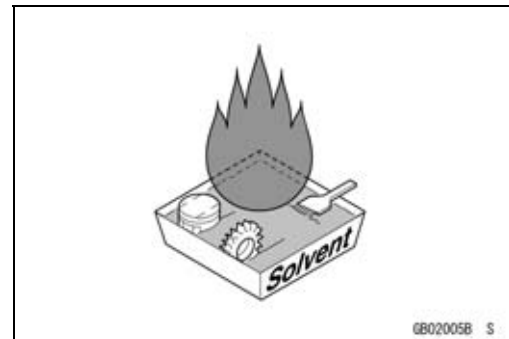

Cleaning vehicle before disassembly

Clean the vehicle thoroughly before disassembly. Dirt or other foreign materials entering into sealed areas during vehicle disassembly can cause excessive wear and decrease performance of the vehicle.

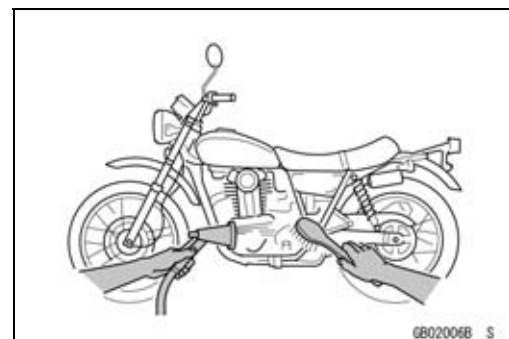

Before Servicing

Arrangement and Cleaning of Removed Parts

Disassembled parts are easy to confuse. Arrange the parts according to the order the parts were disassembled and clean the parts in order prior to assembly.

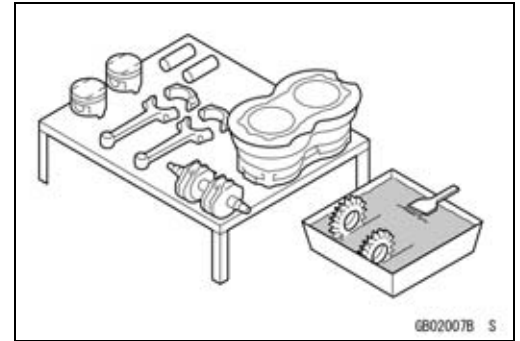

Storage of Removed Parts

After all the parts including subassembly parts have been cleaned, store the parts in a clean area. Put a clean cloth or plastic sheet over the parts to protect from any foreign materials that may collect before re-assembly.

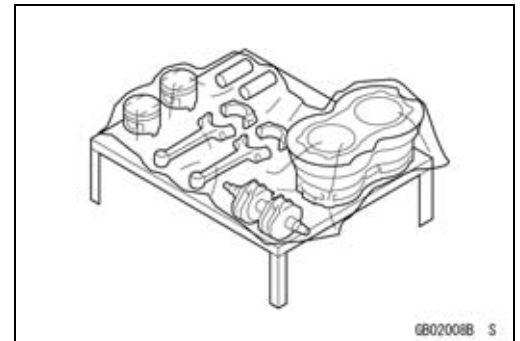

Inspection

Reuse of worn or damaged parts may lead to serious accident. Visually inspect removed parts for corrosion, discoloration, or other damage. Refer to the appropriate sections of this manual for service limits on individual parts. Replace the parts if any damage has been found or if the part is beyond its service limit.

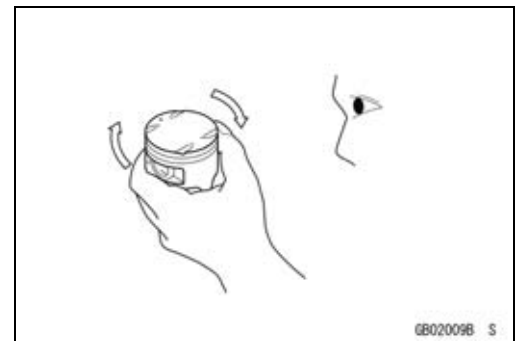

Replacement Parts

Replacement Parts must be KAWASAKI genuine or recommended by KAWASAKI. Gaskets, O rings, Oil seals, Grease seals, circlips or cotter pins must be replaced with new ones whenever disassembled.

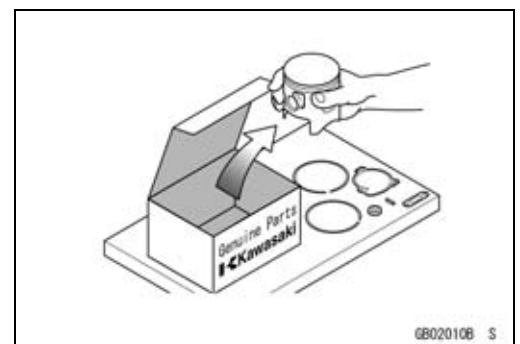

Assembly Order

In most cases assembly order is the reverse of disassembly, however, if assembly order is provided in this Service Manual, follow the procedures given.

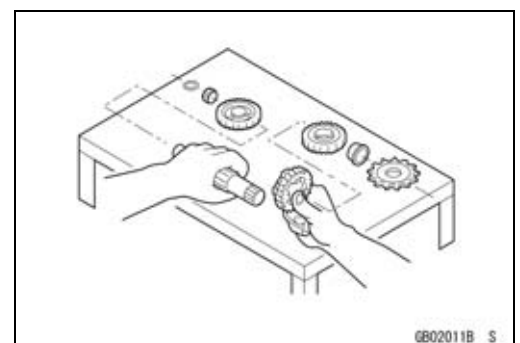

1-4 GENERAL INFORMATION

Before Servicing

Tightening Sequence

Bolts, nuts, or screws must be tightened according to the specified sequence to prevent case warpage or deformation which can lead to malfunction. If the specified tightening sequence is not indicated, tighten the fasteners alternating diagonally.

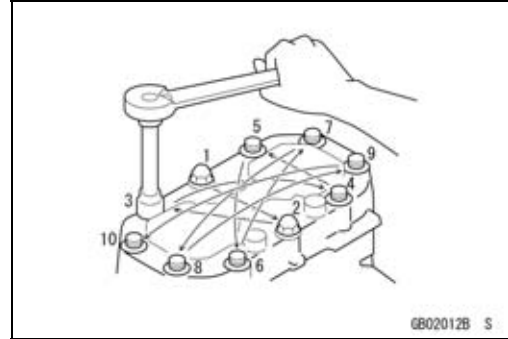

Tightening Torque

Incorrect torque applied to a bolt, nut, or screw may lead to serious damage. Tighten fasteners to the specified torque using a good quality torque wrench. Often, the tightening sequence is followed twice-initial tightening and final tightening with torque wrench.

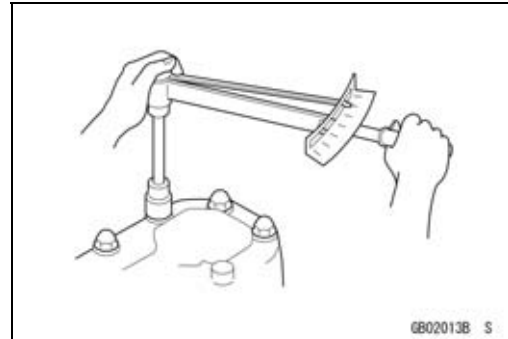

Force

Use common sense during disassembly and assembly, excessive force can cause expensive or hard to repair damage. When necessary, remove screws that have a non-permanent locking agent applied using an impact driver. Use a plastic-faced mallet whenever tapping is necessary.

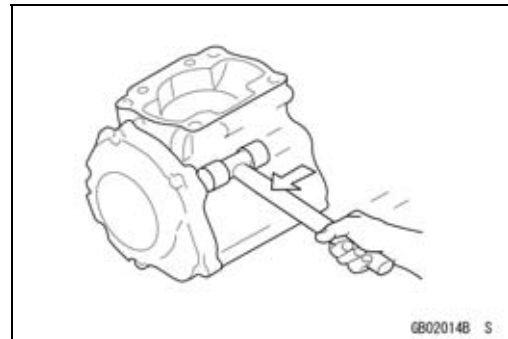

Gasket, Oring

Hardening, shrinkage, or damage of both gaskets and O-rings after disassembly can reduce sealing performance. Remove old gaskets and clean the sealing surfaces thoroughly so that no gasket material or other material remains. Install new gaskets and replace used O-rings when re-assembling.

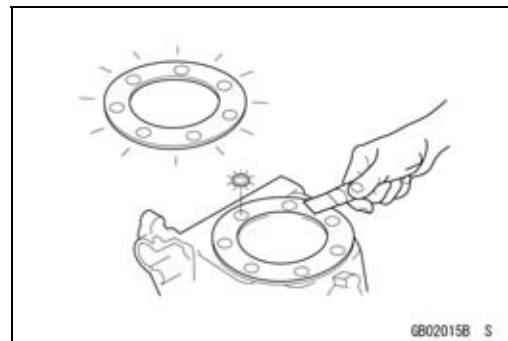

Liquid Gasket, Locking Agent

For applications that require Liquid Gasket or a Locking agent, clean the surfaces so that no oil residue remains before applying liquid gasket or locking agent. Do not apply them excessively. Excessive application can clog oil passages and cause serious damage.



Before Servicing

Press

For items such as bearings or oil seals that must be pressed into place, apply small amount of oil to the contact area. Be sure to maintain proper alignment and use smooth movements when installing.

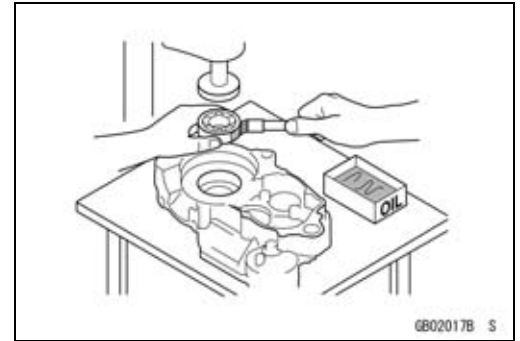

Ball Bearing and Needle Bearing

Do not remove pressed ball or needle unless removal is absolutely necessary. Replace with new ones whenever removed. Press bearings with the manufacturer and size marks facing out. Press the bearing into place by putting pressure on the correct bearing race as shown.

Pressing the incorrect race can cause pressure between the inner and outer race and result in bearing damage.

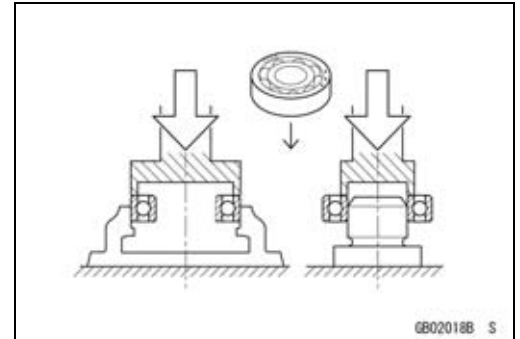

Oil Seal, Grease Seal

Do not remove pressed oil or grease seals unless removal is necessary. Replace with new ones whenever removed. Press new oil seals with manufacture and size marks facing out. Make sure the seal is aligned properly when installing.

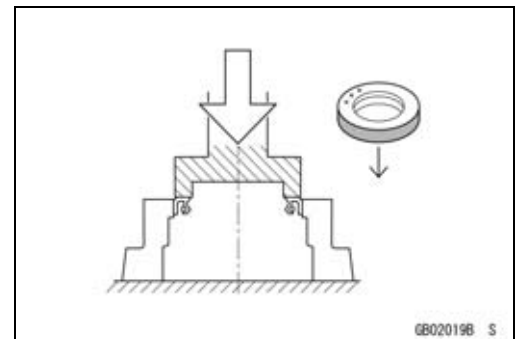

Circlips, Cotter Pins

Replace circlips or cotter pins that were removed with new ones. Install the circlip with its sharp edge facing outward and its chamfered side facing inward to prevent the clip from being pushed out of its groove when loaded. Take care not to open the clip excessively when installing to prevent deformation.

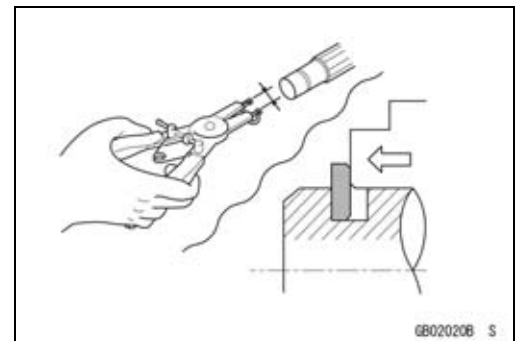

Lubrication

It is important to lubricate rotating or sliding parts during assembly to minimize wear during initial operation. Lubrication points are called out throughout this manual, apply the specific oil or grease as specified.



1-6 GENERAL INFORMATION

Before Servicing

Direction of Engine Rotation

When rotating the crankshaft by hand, the free play amount of rotating direction will affect the adjustment. Rotate the crankshaft to positive direction (clockwise viewed from right side).

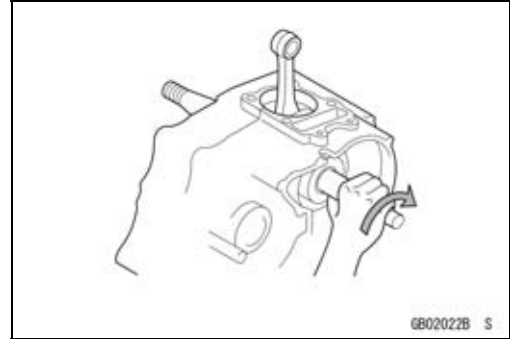

Electrical Wires

A two-color wire is identified first by the primary color and then the stripe color. Unless instructed otherwise, electrical wires must be connected to those of the same color.

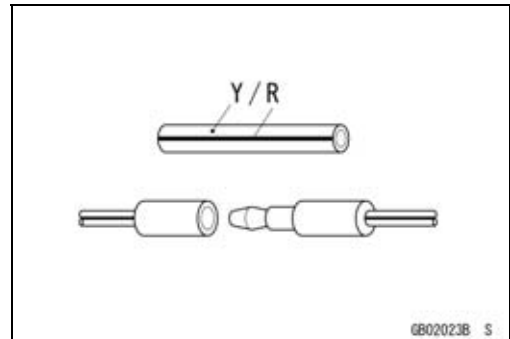

Model Identification

VN2000-A1 (US, and Canada) Left Side View:



VN2000-A1 (US, and Canada) Right Side View:



1-8 GENERAL INFORMATION

Model Identification

VN2000-A1 (Europe) Left Side View:



VN2000-A1 (Europe) Right Side View:



General Specifications

Items	VN2000-A1
<p>Dimensions:</p> <p>Overall length</p> <p>Overall width</p> <p>Overall height</p> <p>Wheelbase</p> <p>Road clearance</p> <p>Seat height</p> <p>Dry mass</p> <p>Curb mass: Front</p> <p> Rear</p> <p>Fuel tank capacity</p> <p>Fuel</p>	<p>2 535 mm (99.80 in.)</p> <p>1 025 mm (40.35 in.), (AU) 985 mm (38.8 in.)</p> <p>1 155 mm (45.47 in.)</p> <p>1 735 mm (68.31 in.)</p> <p>135 mm (5.32 in.)</p> <p>680 mm (26.8 in.)</p> <p>340 kg (750 lb)</p> <p>176 kg (388 lb)</p> <p>195 kg (429 lb)</p> <p>21 L (5.5 US gal)</p> <p>Unleaded and high-octane gasoline (see VN2000-A1 Owner's Manual)</p>
<p>Performance:</p> <p>Minimum turning radius</p>	<p>3.2 m (10.5 ft)</p>
<p>Engine:</p> <p>Type</p> <p>Cooling system</p> <p>Bore and stroke</p> <p>Displacement</p> <p>Compression ratio</p> <p>Maximum horsepower</p> <p>Maximum torque</p> <p>Carburetion system</p> <p>Starting system</p> <p>Ignition system</p> <p>Timing advance</p> <p>Ignition timing Front</p> <p> Rear</p> <p>Spark plugs</p> <p>Cylinder numbering method</p> <p>Firing order</p> <p>Valve timing:</p> <p> Inlet Open</p> <p> Close</p> <p> Duration</p> <p> Exhaust Open</p> <p> Close</p> <p> Duration</p> <p>Lubrication system</p> <p>Engine oil: Type</p> <p> Viscosity</p> <p> Capacity</p>	<p>4-stroke, OHV, V2-cylinder</p> <p>Liquid-cooled</p> <p>103 × 123.2 mm (4.06 × 4.850 in.)</p> <p>2 053 mL (125.3 cu in.)</p> <p>9.5 : 1</p> <p>76 kW (103 PS) @4 800 r/min (rpm), (CA) (CAL) (US) –</p> <p>177 N·m (18.05 kgf·m, 130.6 ft·lb) @3 200 r/min (rpm), (CA) (CAL) (US) –</p> <p>DFI (Digital Fuel Injection) System</p> <p>Electric starter</p> <p>Battery and coil (transistorized)</p> <p>Electronically advanced (digital)</p> <p>From 13° BTDC @900 r/min (rpm) ~ 51° BTDC @4 000 r/min (rpm)</p> <p>From 15° BTDC @900 r/min (rpm) ~ 51° BTDC @4 000 r/min (rpm)</p> <p>NGK IZFR6F-11</p> <p>Front to Rear, 1-2</p> <p>1-2</p> <p>39° BTDC</p> <p>69° ABDC</p> <p>288°</p> <p>69° BBDC</p> <p>39° ATDC</p> <p>288°</p> <p>Forced lubrication (semi-dry sump)</p> <p>API SE, SF or SG class</p> <p>API SH or SJ class with JASO MA</p> <p>SAE10W-40</p> <p>5.5 L (5.8 US qt, when engine is completely disassembled and dry)</p>

1-10 GENERAL INFORMATION

General Specifications

Items	VN2000-A1
Drive Train:	
Primary reduction system:	
Type	Chain
Reduction ratio	1.500 (48/32)
Clutch type	Wet multi disc
Transmission:	
Type	5-speed, constant mesh, return shift
Gear ratios:	
1st	2.550 (51/20)
2nd	1.629 (44/27)
3rd	1.218 (39/32)
4th	0.939 (31/33)
5th	0.729 (27/37)
Final drive system:	
Type	Belt
Reduction ratio	2.744 (50/40 × 72/32), (EU) 2.455 (48/44 × 72/32)
Overall drive ratio	3.003 @ Top gear, (EU) 2.687 @ Top gear
Frame:	
Type	Tubular, double cradle
Caster (rake angel)	32°
Trail	182 mm (7.17 in.)
Front tire:	
Type	Tubeless
Size	150/80 - R16MC 71V
Rear tire:	
Type	Tubeless
Size	200/60 - R16MC 79V
Front suspension:	
Type	Telescopic fork
Wheel travel	150 mm (5.91 in.)
Rear suspension:	
Type	Swingarm with mono-shock (non-link type)
Wheel travel	100 mm (3.94 in.)
Brake Type:	
Front	Dual disc
Rear	Single disc
Electrical Equipment:	
Battery	
Capacity	12 V 18 Ah
Headlight:	
Type	Semi-sealed beam
Bulb	12 V 65 W (quartz-halogen)
	12 V 55 W (quartz-halogen)
Tail/brake light	12 V 5/21 W
Alternator:	
Type	Three-phase AC
Rated output	38A × 14 V @5 000 r/min (rpm)

Specifications are subject to change without notice, and may not apply to every country.

AU: Australia
 CAL: California
 CA: Canada
 US: United States of America
 EU: Europe

Technical Information – Oxygen Sensor

Overview

Kawasaki has adopted an oxygen sensor [A] for the European and California models in addition to the secondary air injection system and honeycomb catalyst. This helps Kawasaki keep the motorcycle with cleaner exhaust gas and cope with the emission regulations.

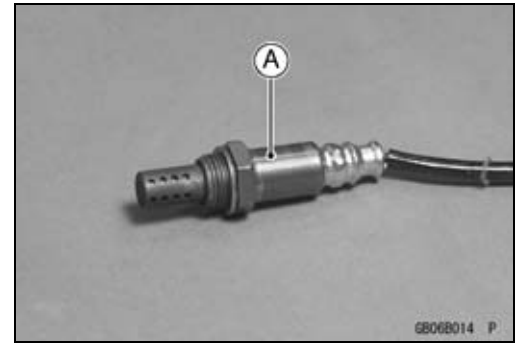

The oxygen sensor [A] is mounted above the exhaust manifold [B], whereas the honeycomb catalyst is located inside the silencer in the downstream of the exhaust gas.

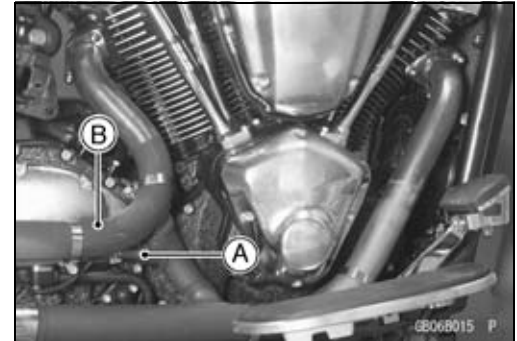

The oxygen sensor uses the substance called zirconia (ZrO_2). The electromotive force varies depending on the density of the oxygen. The sensor measures the oxygen density of the exhaust gas to detect whether the air/fuel mixture is lean or rich in relation to the optimum air/fuel mixture.

When the ECU is in the oxygen sensor feedback mode, it controls combustion by making the fuel injection amount of the injector rich or lean through the signal from the sensor.

1-12 GENERAL INFORMATION

Technical Information – Oxygen Sensor

Construction and Operation

The oxygen sensor uses, a solid electrolyte called zirconia.

An electrolyte is a substance that has positive (+) and negative (-) ions and can move freely in a liquid.

For explanation purposes, picture a solid electrolyte plate as a wall and chambers A and B are divided by this wall. If both sides of the wall have platinum electrodes with holes, the difference in oxygen density (weight) between chambers A and B will move the oxygen from the chamber of higher oxygen density to the chamber of lower oxygen density until the two chambers are about equal in density. What actually moves are the oxygen ions (-) through the wall of the solid electrolyte.

The higher-density-side chamber will receive the "Pt" electrode surface with holes on the solid electrolyte wall and will become minus the oxygen ions (O_2^-). At this point, the O_2^- ions reach the "Pt" electrode of the opposite side.

Since the result of this O_2^- move also brings movement of "e-" (just like "cells" work in a battery), voltage will be built within the sensor.

The (conceptual) sectional view of the actual element in the oxygen sensor is shown. The sensor is exposed to exhaust gas. The shape of the sensor is tubular since the atmospheric side and exhaust gas side are parted by the wall. That means that the inside of this tubular solid electrolyte is the atmosphere side (higher oxygen density), and the outside of the tube faces the exhaust gas. The outside surface, which is in the stream of exhaust gases, has a coated layer of porous ceramic. Voltage is generated and can be measured because of the difference in oxygen density (positive and negative ions).

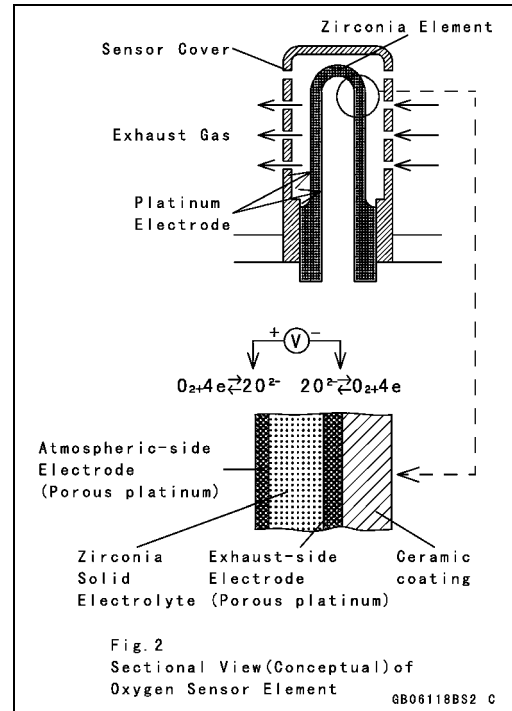
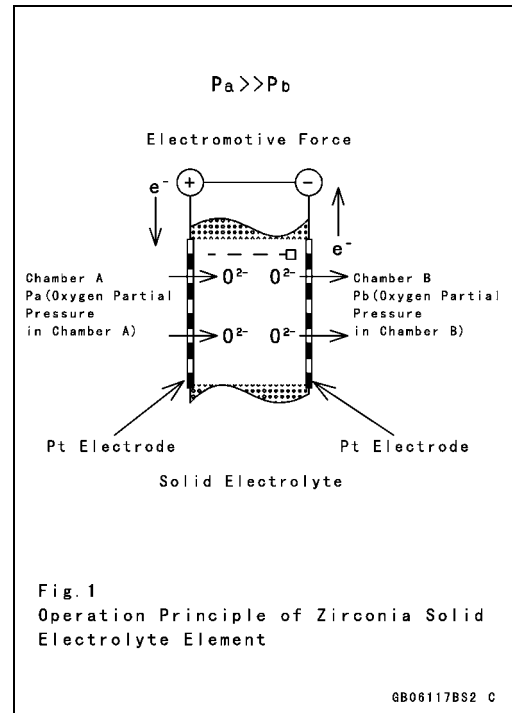

Technical Information – Oxygen Sensor

The sensor, uses the fresh air as the oxygen reference, and consists of a passageway to lead the fresh air inside the tubular element. Installed in this passageway is, a air permeable filter that allows the fresh air to pass through, but won't allow moisture through. This keeps the sensor in touch with the atmosphere.

At a normal temperature, Zirconia (solid electrolyte) is an insulator and not able to sense the gases. Since the exhaust gas temperature does not become hot instantly, it takes sometime before the sensor starts to work. To solve the problem of the slow temperature increase of exhaust gases (which warms the electrolyte element), a built-in heater located inside the tubular element increases the temperature of the sensor so it can operate at a low exhaust gas temperature. Furthermore this built-in heater helps keep the sensor at a constant temperature.

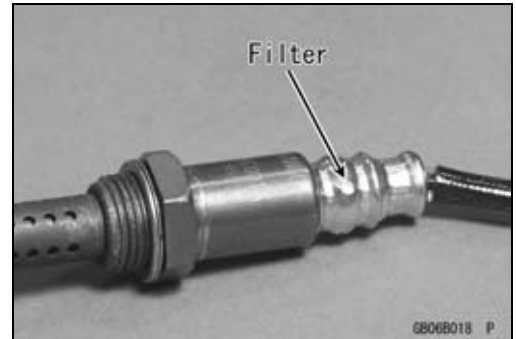
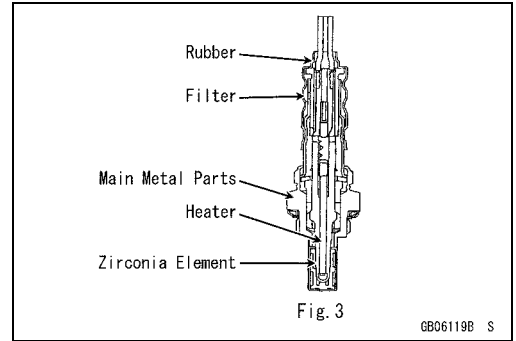

Air/Fuel Ratio Control By Oxygen Sensor

" $\lambda=1$ " indicates the optimum air/fuel ratio point, meaning the air/fuel ratio at which optimum (complete) combustion can be obtained. In the proximity of this mixture, the purification efficiency of the catalyst will be maximized.

The purification ratio of the three kinds of gas, HC (hydrocarbons), CO (carbon monoxide), Nox (nitrogen oxides) using the ternary (three) catalyst is shown in Fig. 4.

The best purification rate is at the zone where the oxygen sensor's signal shows the sharp changes. This zone is called the "window" and if the oxygen sensor signal moves back and forth between the rich side (fuel rich) and lean side (fuel lean) from the optimum mix ratio (but still within the width of the window), it indicates that the exhaust gas is in a good purification rate zone.

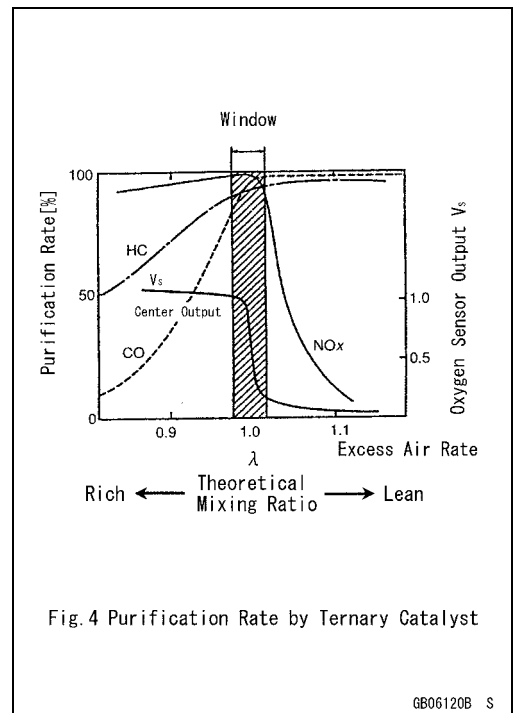

1-14 GENERAL INFORMATION

Technical Information – Oxygen Sensor

Figure 5 shows how the sensor operates the controlling factors.

There is a sharp voltage drop of about 1V (in reality, about 0.9 V) the sensor uses for control (a standard reference). By utilizing this voltage and using 0.45 V as the reference line, an output larger than the line indicates that exhaust gas is in the lean zone. So, when the system senses a “rich” condition through the sensor’s output voltage, it controls the fuel injection amount to make the fuel gradually leaner. When it reaches a leaner point, the sensor voltage signal drops sharply at the proximity $\lambda=1$ and goes below 0.45V. The system, at this level, senses that it has changed to “lean” and reverse the voltage signal to make the fuel richer. It then controls the fuel injection amount to make the fuel gradually richer. When it drops to a richer point, the signal drops sharply at the proximity $\lambda=1$ and goes over 0.45V. The system, at this level, senses that it has changed to “rich” and reverse the signal to make the fuel leaner. By having the signal repeat back and forth between the rich and lean sides, it can constantly stay within the window of the good purification rates. Thereby the oxygen sensor, works as a combustion control sensor for the optimum air/fuel ratio.

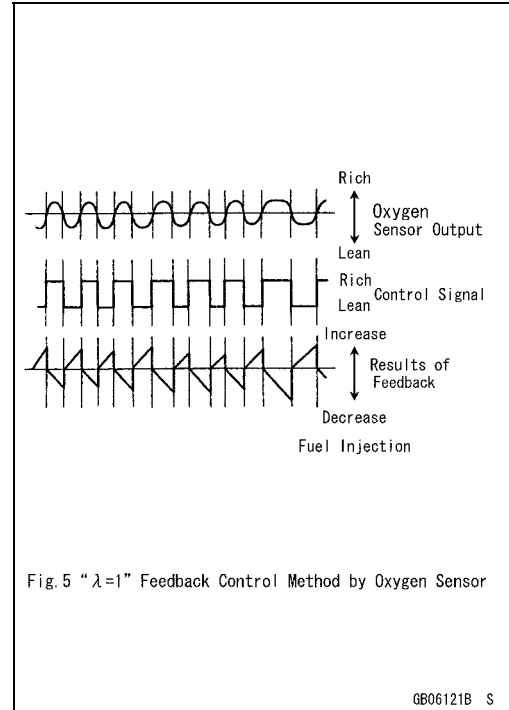

Technical Information – Oxygen Sensor

Maintenance

- 1) Periodic Inspections
Periodic inspections or special maintenance is not required for the sensor.
- 2) Oxygen Sensor Removal and Installation
Handle the oxygen sensor with care. Be careful not to damage sensor wires. Do not service the oxygen sensor while it is hot and not use an impact wrench while removing or installing the oxygen sensor.
Avoid the fouling (damaging) of the sensing part of the sensor with foreign substances such as coolant, battery fluid, anti-corrosion fluid, and brake fluid.
Stop using the sensor if it is fouled with these substances.
Also stop using the sensor if the head part of the sensor (exposed to the atmosphere) is fouled. Since the sensor has a filter that allows air to escape but stop water, fouling of the sensor head may clog this filter.
Being subjected to a flame is also unacceptable for the sensor with the same reason as above.
- 3) Condition of the Sensor
Perform resistance measurements and visually check for scars, bends, and clogging of the sensor filter.
- 4) If trouble with the sensor occurs, one of the following service codes will be displayed. Accordingly, follow the related procedures in the Service Manual for necessary maintenance.

Service Code	Outline of trouble
33	Oxygen sensor is not activated
67	Heater trouble due to wiring short or open
94	Oxygen sensor output voltage is incorrect

1-16 GENERAL INFORMATION

Technical Information – Electric Solenoid Operated Decompressor

An automatic decompressor (Automatic Compression Release) system is installed to the right side of the engine. This decompressor is activated by an electric solenoid to make starting engine easy. When the ignition is switched on and the starter button depressed, the solenoid pulls a fulcrum-mounted link that depresses push rods in each camshaft.

The push rods activate the decompression mechanism to partially open the exhaust valves as the piston nears top dead center, releasing some of compression that can cause resistance during starting.

Releasing the starter button de-activates the solenoid and a spring returns the push rods to their normal operating position.

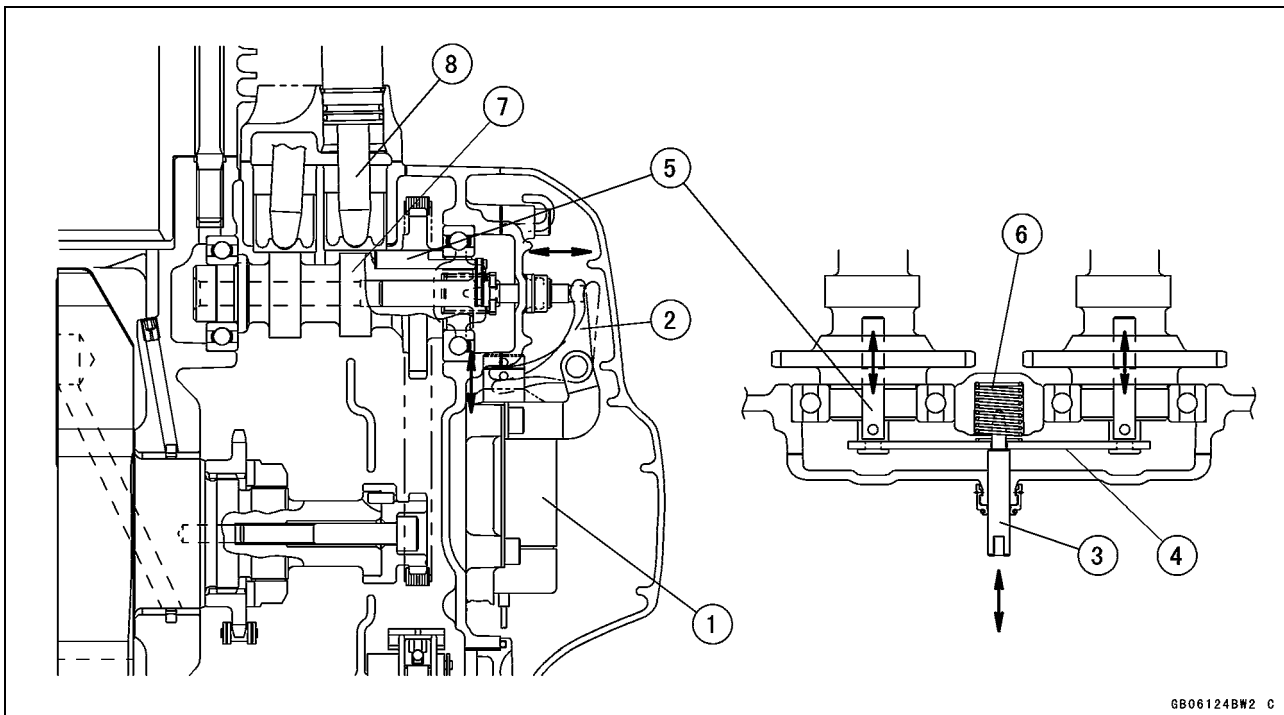

- 1. Decompression Solenoid
- 2. Decompression Lever
- 3. Decompression Push Rod
- 4. Holder

- 5. Decompression Shaft
- 6. Spring
- 7. Exhaust Cam
- 8. Push Rod

Technical Information – Dual Balancer Shaft System

Dual balancers harmonize primary balance and reduce vibration.

The VN2000-A1 engine applied two balancer shafts, one [1] is located in front of the front cylinder and another one [2] is behind the rear cylinder.

Each balancer shaft is driven by the chain which driven to the counterclockwise by crankshaft sprocket that rotate to the clockwise viewed from the right side.

The hydraulically operated chain tensioner is located between crankshaft and rear balancer shaft.

The hydraulic chain tensioner is supplied the oil pressure from lubrication feed pump.

Two chain guides applied, one is between the crankshaft and front balancer shaft and another is under the crankshaft sprocket.

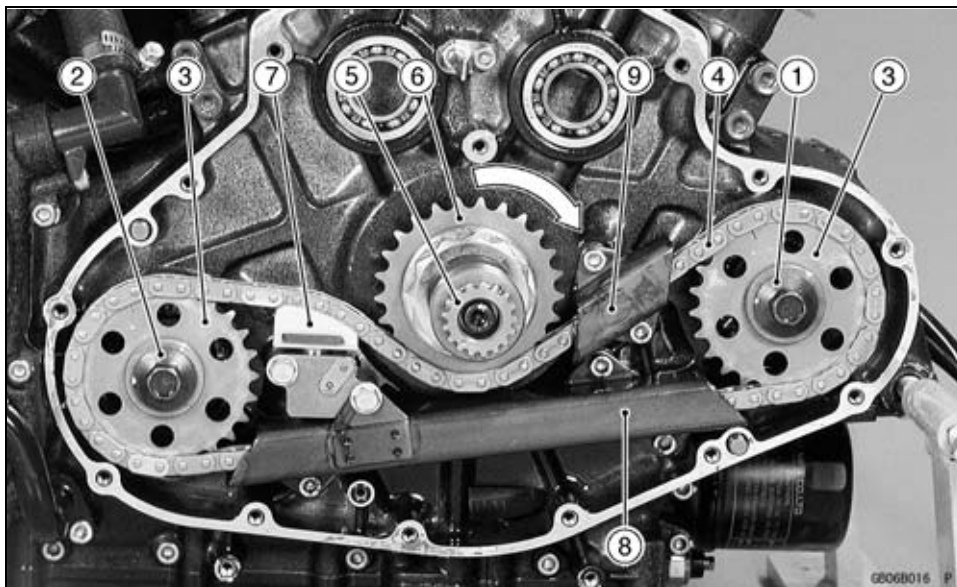
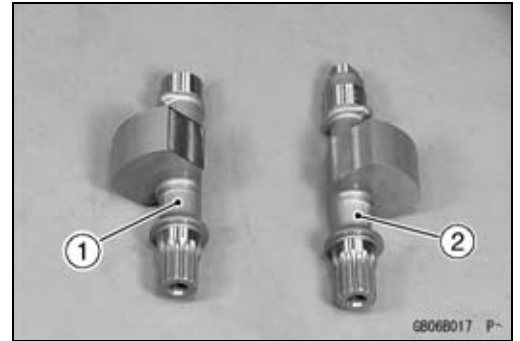

- | | |
|-------------------------------------|--|
| 1. Front Balancer Shaft | 7. Hydraulic Chain Tensioner |
| 2. Rear Balancer Shaft | 8. Chain Guide (under Crankshaft) |
| 3. Front and Rear Balancer Sprocket | 9. Chain Guide (between Crankshaft and Front Balancer Shaft) |
| 4. Balancer Drive Chain | |
| 5. Crankshaft | |
| 6. Balancer Drive Sprocket | |

1-18 GENERAL INFORMATION

Technical Information – Dual Balancer Shaft System

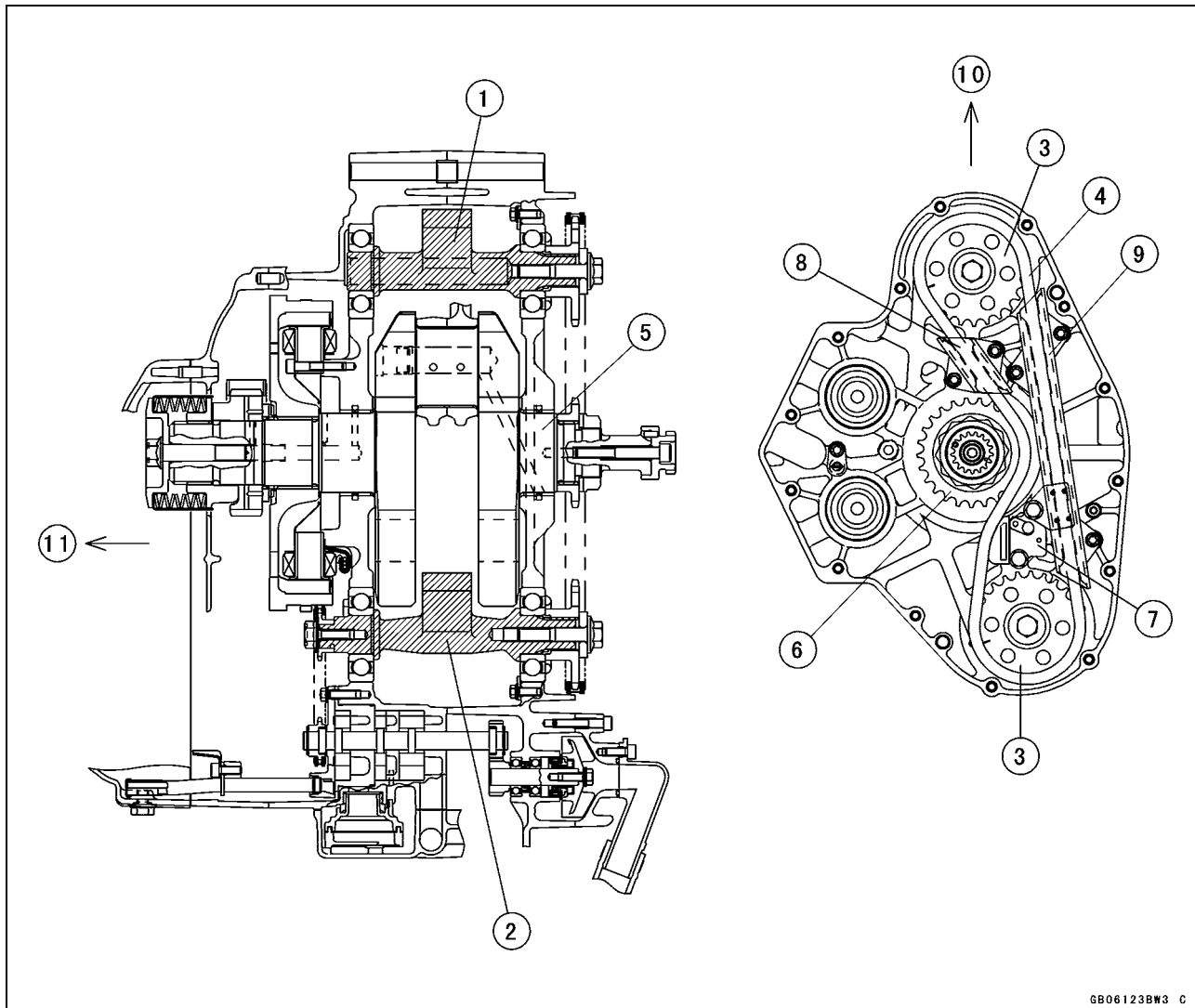

- | | | |
|-------------------------------------|--|-----------------------------------|
| 1. Front Balancer Shaft | 6. Balancer Drive Sprocket | 9. Chain Guide (under Crankshaft) |
| 2. Rear Balancer Shaft | 7. Hydraulic Chain Tensioner | 10. Front |
| 3. Front and Rear Balancer Sprocket | 8. Chain Guide (between Crankshaft and Front Balancer Shaft) | 11. Left |
| 4. Balancer Drive Chain | | |
| 5. Crankshaft | | |

Unit Conversion Table

Prefixes for Units:

Prefix	Symbol	Power
mega	M	× 1 000 000
kilo	k	× 1 000
centi	c	× 0.01
milli	m	× 0.001
micro	μ	× 0.000001

Units of Mass:

kg	×	2.205	=	lb
g	×	0.03527	=	oz

Units of Volume:

L	×	0.2642	=	gal (US)
L	×	0.2200	=	gal (imp)
L	×	1.057	=	qt (US)
L	×	0.8799	=	qt (imp)
L	×	2.113	=	pint (US)
L	×	1.816	=	pint (imp)
mL	×	0.03381	=	oz (US)
mL	×	0.02816	=	oz (imp)
mL	×	0.06102	=	cu in.

Units of Force:

N	×	0.1020	=	kgf
N	×	0.2248	=	lb
kg	×	9.807	=	N
kg	×	2.205	=	lb

Units of Length:

km	×	0.6214	=	mile
m	×	3.281	=	ft
mm	×	0.03937	=	in.

Units of Torque:

N·m	×	0.1020	=	kgf·m
N·m	×	0.7376	=	ft·lb
N·m	×	8.851	=	in·lb
kgf·m	×	9.807	=	N·m
kgf·m	×	7.233	=	ft·lb
kgf·m	×	86.80	=	in·lb

Units of Pressure:

kPa	×	0.01020	=	kgf/cm ²
kPa	×	0.1450	=	psi
kPa	×	0.7501	=	cm Hg
kgf/cm ²	×	98.07	=	kPa
kgf/cm ²	×	14.22	=	psi
cm Hg	×	1.333	=	kPa

Units of Speed:

km/h	×	0.6214	=	mph
------	---	--------	---	-----

Units of Power:

kW	×	1.360	=	PS
kW	×	1.341	=	HP
PS	×	0.7355	=	kW
PS	×	0.9863	=	HP

Units of Temperature:

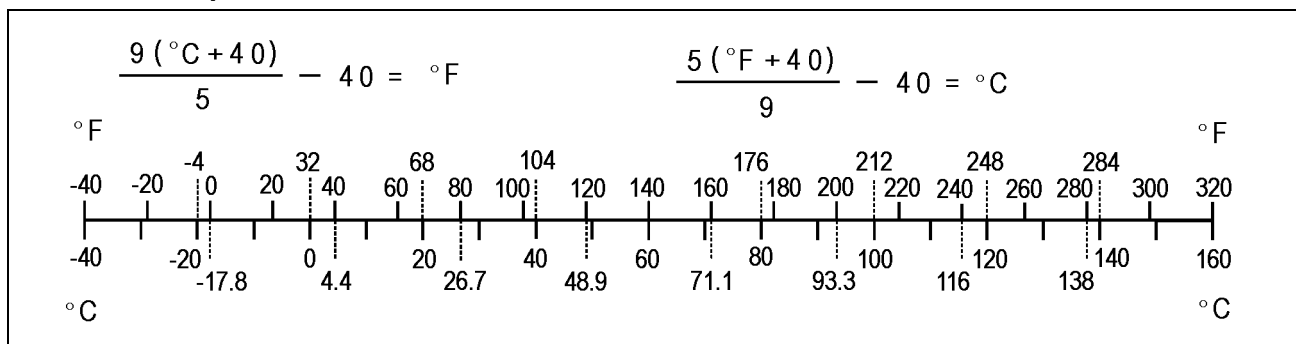

Periodic Maintenance

Table of Contents

Periodic Maintenance Chart	2-2	Headlight Aiming Inspection	2-30
Torque and Locking Agent.....	2-5	Side Stand Switch Operation	
Specifications	2-11	Inspection.....	2-31
Special Tools	2-13	Engine Stop Switch Operation	
Periodic Maintenance Procedures.....	2-14	Inspection.....	2-32
Steering System:	2-14	Fuel System (DFI):.....	2-32
Steering Play Inspection	2-14	Throttle Control System	
Steering Play Adjustment.....	2-14	Inspection.....	2-32
Steering Stem Bearing		Idle Speed Inspection	2-33
Lubrication.....	2-15	Fuel Hose and Connection	
Brake System:	2-15	Inspection.....	2-33
Brake Fluid Leak (Brake Hose		Cooling System.....	2-34
and Pipe).....	2-15	Coolant Level Inspection.....	2-34
Brake Hose Damage and		Radiator Hose and Connection	
Installation Connection		Inspection.....	2-34
Inspection.....	2-16	Evaporative Emission Control	
Brake Operation Inspection	2-16	System Inspection(CAL):	2-35
Brake Fluid Level Inspection.....	2-16	Evaporative Emission Control	
Brake Pad Wear Inspection	2-17	System Inspection.....	2-35
Brake Light Switch Operation	2-17	Air Suction System:	2-36
Wheel and Tires:.....	2-18	Air Switching Valve Operation	
Tire Air Pressure Inspection.....	2-18	Test.....	2-36
Wheel/Tire Damage Inspection....	2-18	Others:.....	2-36
Tire Tread Wear Inspection.....	2-18	Chassis Parts Lubrication	2-36
Wheel Bearing Damage		Bolts and Nuts Tightness	
Inspection.....	2-19	Inspection.....	2-37
Suspensions	2-19	Replacement Parts:	2-39
Front Forks/Rear Shock Absorber		Brake Hose and Pipe	
Operation Inspection	2-19	Replacement.....	2-39
Front Fork Oil Leak Inspection....	2-20	Brake Fluid Change	2-39
Rear Shock Absorber Oil Leak		Master Cylinder Rubber Parts	
Inspection	2-20	Replacement.....	2-41
Swingarm Pivot Lubrication	2-20	Caliper Rubber Parts	
Clutch and Drive Train:	2-21	Replacement.....	2-42
Clutch Operation	2-21	Spark Plug Replacement	2-45
Belt Deflection Inspection	2-21	Air Cleaner Element	
Belt Deflection Adjustment.....	2-23	Replacement.....	2-46
Wheel Alignment		Engine Oil Change.....	2-47
Inspection/Adjustment.....	2-24	Oil Filter Replacement	2-49
Belt Wear and Damage		Fuel Hose Replacement	2-49
Inspection.....	2-25	Coolant Change	2-50
Electrical System:	2-27	Radiator Hose and O-ring	
Spark Plug Condition Inspection..	2-27	Replacement.....	2-53
Lights and Switches Operation ...	2-28		

2-2 PERIODIC MAINTENANCE

Periodic Maintenance Chart

The scheduled maintenance must be done in accordance with this chart to keep the motorcycle in good running condition. **The initial maintenance is vitally important and must not be neglected.**

Periodic Inspection:

INSPECTION	FREQUENCY	* ODOMETER READING × 1000 km (× 1000 mile)							
		Whichever comes first ↓ Every	1 (0.6)	6 (4)	12 (7.5)	18 (12)	24 (15)	30 (20)	36 (24)
Steering System:									
Steering play - inspect	year	•		•		•		•	2-14
Steering stem bearing - lubricate	2 year					•			2-15
Brake System:									
Brake fluid leak (brake hose and pipe)-inspect	year	•	•	•	•	•	•	•	2-15
Brake hose damage - inspect	year	•	•	•	•	•	•	•	2-16
Brake hose installation condition - inspect	year	•	•	•	•	•	•	•	2-16
Brake operation (effectiveness, no drag) - inspect	year	•	•	•	•	•	•	•	2-16
Brake fluid level - inspect	6 month	•	•	•	•	•	•	•	2-16
Brake pad wear - inspect #			•	•	•	•	•	•	2-17
Brake light switch operation - inspect		•	•	•	•	•	•	•	2-17
Wheels and Tires:									
Tire air pressure - inspect	year			•		•		•	2-18
Wheel/tire damage - inspect				•		•		•	2-18
Tire tread wear, abnormal wear - inspect				•		•		•	2-18
Wheel bearing damage - inspect	year			•		•		•	2-19
Suspensions:									
Front forks/rear shock absorber operation (smooth stroke) - inspect				•		•		•	2-19
Front forks/rear shock absorber oil leak - inspect	year			•		•		•	2-20
Swingarm pivot - lubrication						•			2-20
Clutch and Drive Train:									
Clutch operation (play, disengagement, engagement) - inspect		•		•		•		•	2-21
Belt deflection - inspect		•	•	•	•	•	•	•	2-21
Belt wear and damage - inspect		•	•	•	•	•	•	•	2-24
Electrical System:									
Spark plug condition - Inspect				•		•		•	2-27
Lights and switches operation - inspect	year			•		•		•	2-28
Headlight aiming - inspect	year			•		•		•	2-30
Side stand switch operation - inspect	year			•		•		•	2-31
Engine stop switch operation - inspect	year			•		•		•	2-32

Periodic Maintenance Chart

FREQUENCY	* ODOMETER READING × 1000 km (× 1000 mile)								
	Whichever comes first ↓ Every	1 (0.6)	6 (4)	12 (7.5)	18 (12)	24 (15)	30 (20)	36 (24)	See Page
INSPECTION									
Fuel System:									
Throttle control system (play, smooth return, no drag) - inspect	year	•		•		•		•	2-32
Idle speed - inspect		•		•		•		•	2-33
Fuel leak (fuel hose and pipe) - inspect	year	•		•		•		•	2-33
Fuel hoses and pipe damage - inspect	year	•		•		•		•	2-33
Fuel hoses and pipe installation condition - inspect	year	•		•		•		•	2-33
Cooling System:									
Coolant level - inspect		•		•		•		•	2-34
Coolant leak (radiator hose and pipe) - inspect	year	•		•		•		•	2-34
Radiator hose and pipe damage - inspect	year	•		•		•		•	2-34
Radiator hose and pipe installation condition - inspect	year	•		•		•		•	2-34
Evaporative Emission Control System (CAL):									
Evaporative emission control system function - inspect		•	•	•	•	•	•	•	2-35
Air Suction System:									
Air suction system damage - inspect				•		•		•	2-36
Others:									
Chassis parts - lubricate	year			•		•		•	2-36
Bolts and nuts tightness - inspect		•		•		•		•	2-37

: Service more frequently when operating in severe conditions; dusty, wet, muddy, high speed or frequent starting/stopping.

* : For higher odometer readings, repeat at the frequency interval established here.

(CAL): California

2-4 PERIODIC MAINTENANCE

Periodic Maintenance Chart

Periodic Replacement Parts:

CHANGE/REPLACE ITEM	FREQUENCY	Whichever comes first ↓ Every	* ODOMETER READING × 1000 km (× 1000 mile)					See Page
			1 (0.6)	12 (7.5)	24 (15)	36 (24)	48 (30)	
Brake hoses and pipes	4 year					●	2-39	
Brake fluid	2 year			●		●	2-39	
Rubber parts of master cylinder and caliper	4 year					●	2-41	
Spark plug						●	2-45	
Air cleaner element #					●		2-46	
Engine oil #	year	●	●	●	●	●	2-47	
Oil filter	year	●	●	●	●	●	2-49	
Fuel hose	4 year					●	2-49	
Coolant	3 year				●		2-50	
Radiator hose and O-ring	3 year				●		2-53	

: Service more frequently when operating in severe conditions; dusty, wet, muddy, high speed or frequent starting/stopping.

* : For higher odometer readings, repeat at the frequency interval established here.

Torque and Locking Agent

The following tables list the tightening torque for the major fasteners requiring use of a non-permanent locking agent or liquid gasket.

Letters used in the "Remarks" column mean:

- L:** Apply a non-permanent locking agent to the threads.
- G:** Apply grease to the threads.
- MO:** Apply molybdenum disulfide grease oil solution.
- O:** Apply oil to the threads and seating surface.
- S:** Tighten the fasteners following the specified sequence.
- SS:** Apply silicone sealant.
- Si:** Apply silicone grease (ex. PBC grease).
- R:** Replacement parts
- Lh:** Left-hand-threads
- St:** Stake the fasteners to prevent loosening.
- AL:** Tighten the two clamp bolts alternately two times to ensure even tightening torque.

The table below, relating tightening torque to thread diameter, lists the basic torque for the bolts and nuts. Use this table for only the bolts and nuts which do not require a specific torque value. All of the values are for use with dry solvent-cleaned threads.

Basic Torque for General Fasteners

Threads dia. (mm)	Torque		
	N·m	kgf·m	ft·lb
5	3.4 ~ 4.9	0.35 ~ 0.50	30 ~ 43 in·lb
6	5.9 ~ 7.8	0.60 ~ 0.80	52 ~ 69 in·lb
8	14 ~ 19	1.4 ~ 1.9	10.0 ~ 13.5
10	25 ~ 34	2.6 ~ 3.5	19.0 ~ 25
12	44 ~ 61	4.5 ~ 6.2	33 ~ 45
14	73 ~ 98	7.4 ~ 10.0	54 ~ 72
16	115 ~ 155	11.5 ~ 16.0	83 ~ 115
18	165 ~ 225	17.0 ~ 23.0	125 ~ 165
20	225 ~ 325	23 ~ 33	165 ~ 240

Fastener	Torque			Remarks
	N·m	kgf·m	ft·lb	
Fuel System:				
Fuel pump bolts	9.8	1.0	87 in·lb	S, L
Water temperature sensor	12	1.2	104 in·lb	
Oxygen sensor	44	4.5	33	
Gear position switch mounting bolts	6.9	0.70	61 in·lb	
Gear position switch lead clamp bolts	6.9	0.70	61 in·lb	
Camshaft position sensor bolt	9.8	1.0	87 in·lb	L
Fuel level sensor mounting bolts	6.9	0.70	61 in·lb	L
Speed sensor mounting bolt	9.8	1.0	87 in·lb	L
Delivery joint bolts	9.8	1.0	87 in·lb	L
Throttle body assy holder bolts	9.8	1.0	87 in·lb	L
Inlet manifold bolts	9.8	1.0	87 in·lb	L
Air cleaner housing bolts	9.8	1.0	87 in·lb	
Air cleaner housing Allen bolts	9.8	1.0	87 in·lb	
Cooling System:				
Water temperature sensor	12	1.2	104 in·lb	
Water pipe bolts	9.8	1.0	87 in·lb	
Radiator fan bolts	8.3	0.85	74 in·lb	
Reserve tank bolts	6.9	0.70	61 in·lb	
Radiator cover bolts	11	1.1	97 in·lb	
Water pump impeller bolt	12	1.2	104 in·lb	Lh
Water pipe drain bolt	9.8	1.0	87 in·lb	
Water pump air bleeder bolt	7.8	0.80	69 in·lb	
Radiator screen screws	6.9	0.70	61 in·lb	

2-6 PERIODIC MAINTENANCE

Torque and Locking Agent

Fastener	Torque			Remarks
	N·m	kgf·m	ft·lb	
Engine Top End:				
Rocker case cover bolts	12	1.2	104 in·lb	S, AL
Rocker case bolts	15	1.5	11	S
Oil pipe banjo bolts	54	5.5	40	
Oil pipe bolts	9.8	1.0	87 in·lb	
Upper cylinder head nuts, ϕ 10 mm	15	1.5	11	first, S, MO
Upper cylinder head nuts, ϕ 10 mm	29	3.0	21	final, S, MO
Upper cylinder head nuts, ϕ 12 mm	29	3.0	21	first, S, MO
Upper cylinder head nuts, ϕ 12 mm	88	9.0	65	final, S, MO
Lower cylinder head nuts	25	2.5	18	S
Water jacket plugs	22	2.2	16	L
Water jacket plugs	15	1.5	11	L
Rocker shaft bolts	12	1.2	104 in·lb	
Cylinder mounting bolts	25	2.5	18	L
Coolant drain bolt	9.8	1.0	87 in·lb	
Push rod cover bolts	12	1.2	104 in·lb	
Camshaft chain guide bolts	12	1.2	104 in·lb	L
Camshaft chain tensioner bolts	12	1.2	104 in·lb	
Inner camshaft cover bolts	12	1.2	104 in·lb	
Stopper pin plug	2.5	0.25	22 in·lb	L
Middle camshaft cover bolts	12	1.2	104 in·lb	
Middle camshaft cover bolts L 35 mm	12	1.2	104 in·lb	
Camshaft end cover bolts	12	1.2	104 in·lb	
Decompression solenoid bolts	9.8	1.0	87 in·lb	
Outer camshaft cover bolts	12	1.2	104 in·lb	
Muffler bracket bolts	25	2.5	18	
Muffler cover clamp screws	6.9	0.7	61 in·lb	
Clutch:				
Primary chain upper guide bolts	9.8	1.0	87 in·lb	
Primary chain lower guide bolts	9.8	1.0	87 in·lb	
Cam damper bolt	69	7.0	51	
Inner clutch cover bolts	12	1.2	104 in·lb	S, see text
Outside plate bolt	9.8	1.0	87 in·lb	L
Clutch hub nut	135	14.0	101	MO
Clutch spring bolts	98	1.0	87 in·lb	
Outer clutch cover bolts	12	1.2	104 in·lb	S, see text
Plug on outer clutch cover	20	2.0	14	
Clutch cover oil drain plug	21	2.1	15	
Clutch release lever bolt	5.9	0.60	52 in·lb	
Starter lockout switch screw	–	–	–	L
Inside plate bolt	9.8	1.0	87 in·lb	

Torque and Locking Agent

Fastener	Torque			Remarks
	N·m	kgf·m	ft·lb	
Engine Lubrication System:				
Rocker shaft oil pipe bolts	98	1.0	87 in·lb	
Cylinder head oil pipe banjo bolts	54	5.4	40	
Oil filter	17.5	1.75	12.5	
Oil passage bolt	29	3.0	21	
Oil passage adapter drain plug	9.8	1.0	87 in·lb	
Relief valve	15	1.5	11	L
Camshaft oil pipe bolt	9.8	1.0	87 in·lb	
Oil pipe bolt L16	9.8	1.0	87 in·lb	L
Oil pipe bolt L30	12	1.2	104 in·lb	
Oil pump drive sprocket bolt	29	3.0	21	
Oil pump chain tensioner bolt	12	1.2	104 in·lb	
Oil pump cover bolts	9.8	1.0	87 in·lb	
Inside plate bolt	9.8	1.0	87 in·lb	
Outside plate bolt	9.8	1.0	87 in·lb	L
Clutch cover drain plug	21	2.1	15	
Oil pressure switch	15	1.5	11	SS
Oil passage adapter	20	2.0	14	L
Oil pan plug	20	2.0	14	L
Oil pipe stopper bolt	6.9	0.7	61 in·lb	
Oil screen bolt for crank room	9.8	1.0	87 in·lb	
Oil pan bolts	15	1.5	11	S
Left oil pan drain plug	20	2.0	14	
Right oil pan drain plug	15	1.5	11	
Engine Removal/Installation:				
Front downtube nuts	88	9.0	65	S, AL
Upper adjusting bolt	9.8	1.0	87 in·lb	S
Lower adjusting bolt	9.8	1.0	87 in·lb	S
Upper adjusting bolt locknut	49	5.0	36	S
Lower adjusting bolt locknut	49	5.0	36	S
Upper rear engine mounting nut	59	6.0	43	S
Lower rear engine mounting nut	59	6.0	43	S
Upper engine bracket nuts	59	6.0	43	S, AL
Upper engine mounting bolts	44	4.5	33	S
Lower engine bracket bolts	59	6.0	43	S
Front engine mounting nut	44	4.5	33	S
Rear downtube bolts 14	108	11.0	80	S, AL
Crankshaft/Transmission:				
Connecting rod big end bolts	59	6.0	43	MO
Balancer chain sprocket nut	125	13.0	92.2	MO
Camshaft chain sprocket bolt	29	3.0	22	
Camshaft balancer gear bolts	83	8.5	61	

2-8 PERIODIC MAINTENANCE

Torque and Locking Agent

Fastener	Torque			Remarks
	N·m	kgf·m	ft·lb	
Upper balancer chain guide bolts	12	1.2	104 in·lb	
Lower balancer chain guide bolts	12	1.2	104 in·lb	
Balance chain tensioner bolts	12	1.2	104 in·lb	
Bearing retainer screws at output shaft	6.9	0.7	61 in·lb	
Bearing retainer bolts	–	–	–	L
Speed sensor bolt	9.8	1.0	87 in·lb	L
Bearing retainer screws at pulley shaft	6.9	0.7	61 in·lb	
Crankcase bolts, $\phi 8$	29	3.0	22	S
Crankcase bolts, $\phi 6$	12	1.2	104 in·lb	S
Outer transmission cover bolts	12	1.2	104 in·lb	S,see text
Inner transmission cover bolts	12	1.2	104 in·lb	S,see text
Transfer gear nut (Output shaft)	196	20.0	145	MO, Lh
Transfer gear nut (Pulley shaft)	78	8.0	58	MO
Gear set lever nut	7.8	0.8	69 in·lb	
Shift shaft return spring pin	39	4.0	30	L
Rear shift lever bolt	25	2.5	18	
Front shift lever clamp bolt	25	2.5	18	
Shift dram cam bolt	12	1.2	104 in·lb	L
Rear shift rod locknut	9.8	1.0	87 in·lb	Lh
Front shift rod locknut	9.8	1.0	87 in·lb	
Engine pulley mounting nut	177	18	130	MO
Wheels/Tires:				
Front axle nut	127	13	94	
Front axle clamp bolts	20	2.0	15	AL
Rear axle nut	108	11	80	
Tire air valve nuts	1.5	0.15	13 in·lb	
Tire air valve cap	0.15	0.015	1.3 in·lb	
Final Drive:				
Engine pulley inside cover bolts	12	1.2	104 in·lb	
Engine pulley mounting nut	177	18	130	MO
Rear axle nut	108	11	80	
Rear coupling stud bolts	44	4.5	33	L
Ring screws	6.9	0.70	61 in·lb	
Rear pulley mounting nuts	69	7.0	51	
Brakes:				
Brake hose banjo bolts	25	2.5	18	
Front brake reservoir cap screws	1.5	0.15	13 in·lb	
Brake lever pivot bolt	1.0	0.10	8.7 in·lb	Si
Brake lever pivot bolt locknut	5.9	0.60	52 in·lb	
Front brake light switch screw	1.2	0.12	10 in·lb	
Front master cylinder clamp bolts	8.8	0.90	78 in·lb	S
Brake disc bolts	27	2.8	20	L

Torque and Locking Agent

Fastener	Torque			Remarks
	N·m	kgf·m	ft·lb	
Front caliper mounting bolts	25	2.5	18	
Front caliper assembly bolts	21	2.1	15	
Front brake pad pins	15	1.5	11	
Caliper bleed valves	7.8	0.80	69 in·lb	
Front brake pad spring bolts	2.9	0.30	26 in·lb	
Rear master cylinder mounting bolts	25	2.5	18	
Rear master cylinder push rod locknut	17	1.7	12	
Brake pedal clamp bolt	25	2.5	18	
Rear caliper mounting bolts	34	3.5	25	
Suspension:				
Upper front fork clamp bolts	20	2.0	15	
Lower front fork clamp bolts	34	3.5	25	AL
Cover stopper bolts	4.2	0.43	37 in·lb	
Front axle clamp bolts	25	2.5	18	AL
Front fork bottom Allen bolts	23	2.3	17	L
Rear shock absorber mounting bolt and nut	59	6.0	43	
Swingarm pivot shaft nut	127	13	94	
Steering:				
Handlebar clamp bolts	34	3.5	25	O, S
Handlebar holder nuts	34	3.5	25	
Steering stem head nut	108	11	80	
Upper front fork clamp bolts	20	2.0	15	
Steering stem nut	4.9	0.50	43 in·lb	
Lower front fork clamp bolts	34	3.5	25	AL
Frame:				
Front downtube nuts	88	9.0	65	S
Upper engine bracket nuts	59	6.0	43	S
Upper engine mounting bolts	44	4.5	33	S
Lower engine bracket bolts	59	6.0	43	S
Rear downtube bolts	108	11	80	S
Side stand mounting bolt	44	4.5	33	S
Side stand mounting nut	44	4.5	33	S
Adjust bolts	9.8	1.0	87 in·lb	S
Footboard bracket bolts	34	3.5	25	
Front engine mounting nut	44	4.5	33	S
Adjusting bolt locknuts	49	5.0	36	S
Rear engine mounting nuts	59	6.0	43	S
Side stand switch mounting bolt	8.8	0.90	78 in·lb	L
Footpeg bracket bolts	25	2.5	18	
Muffler bracket mounting bolts	25	2.5	18	
Electrical System:				
Spark plugs	18	1.8	13	

2-10 PERIODIC MAINTENANCE

Torque and Locking Agent

Fastener	Torque			Remarks
	N·m	kgf·m	ft·lb	
Alternator stator coil mounting bolts	12	1.2	104 in·lb	L
Crankshaft sensor mounting bolts	6.9	0.70	61 in·lb	
Oil pressure switch	15	1.5	11	SS
Speed sensor mounting bolt	9.8	1.0	87 in·lb	L
Gear position switch mounting bolts	4.9	0.50	43 in·lb	L
Gear position switch lead clamp bolts	4.9	0.50	43 in·lb	L
Side stand switch mounting bolt	8.8	0.90	78 in·lb	L
Regulator/rectifier bolts	8.8	0.90	78 in·lb	
Oxygen sensor	44	4.5	33	
Water temperature sensor	12	1.2	104 in·lb	
Camshaft position sensor bolt	9.8	1.0	87 in·lb	L
Decompression solenoid bolts	9.8	1.0	87 in·lb	
Starter lockout switch screw	1.2	0.12	10 in·lb	
Front brake light switch screw	1.2	0.12	10 in·lb	
Fuel level sensor mounting bolts	6.9	0.70	61 in·lb	L
Fuel pump mounting bolts	9.8	1.0	87 in·lb	L, S
Starter motor terminal nut	9.8	1.0	87 in·lb	
Starter motor terminal locknut	11	1.1	95 in·lb	
Starter motor mounting bolts	9.8	1.0	87 in·lb	
Starter motor assembly bolts	4.9	0.50	43 in·lb	
Turn signal light lens screws	1.0	0.10	8.7 in·lb	
Front turn signal light screws	6.9	0.70	61 in·lb	
Tail/brake light unit mounting nuts	5.9	0.60	52 in·lb	
Rear turn signal light screws	6.9	0.70	61 in·lb	
License plate light lens mounting screws	1.2	0.12	10 in·lb	

Specifications

Item	Standard	Service Limit
Fuel System (DFI):		
Throttle grip free play	2 ~ 3 mm (0.08 ~ 0.12 in.)	---
Idle speed	900 ± 50 r/min (rpm)	---
Air cleaner element	Viscous paper element	---
Cooling System:		
Coolant:		
Type (recommended)	Permanent type antifreeze	---
Color	Green	---
Mixed ratio	Soft water 50%, Coolant 50%	---
Freezing point	-35°C (-31°F)	---
Total amount	2.5 L (2.6 US qt)	---
Engine Top End:		
Valve clearance	Non-adjustable (hydraulic lash adjusters)	---
Clutch:		
Clutch lever free play	2 ~ 3 mm (0.08 ~ 0.12 in.)	---
Engine Lubrication System:		
Engine oil:		
Type	API SE, SF or SG API SH or SJ with JASO MA	---
Viscosity	SAE 10W-40	---
Capacity	4.4 L (4.7 US qt, when filter is not removed) 4.6 L (4.9 US qt, when filter is removed) 5.5 L (5.8 US qt, when engine is completely disassembled and dry)	---
Level	Between upper and lower level lines (Wait 2 ~ 3 minutes after idling or running)	---
Tires:		
Tread depth:		
Front	BRIDGESTONE BATTLAX BT020F 4.3 mm (0.17 in.)	1 mm (0.04 in.), (DE, AT, CH): 1.6 mm (0.063 in.)
Rear	BRIDGESTONE BATTLAX BT020R 7.0 mm (0.28 in.)	Up to 130 km/h (80 mph): 2 mm (0.08 in.) Over 130km/h (80mph): 3 mm (0.1 in.)
Air pressure: (when cold)		
Front	Up to 186 kg (410 lb) load: 250 kPa (2.5 kgf/cm ² , 36 psi)	---
Rear	Up to 186 kg (410 lb) load: 290 kPa (3.0 kgf/cm ² , 42 psi)	---

2-12 PERIODIC MAINTENANCE

Specifications

Item	Standard	Service Limit
Final Drive:		
Drive belt deflection: (44.1 N, 4.5 kgf, 10 lb force)	2.5 ~ 4.0 mm (0.10 ~ 0.16 in.)	---
when installing new belt or engine remounted	2.5 mm (0.10 in.)	---
Brakes:		
Brake fluid		
Grade	DOT4	---
Brake pad lining thickness:		
Front	4.0 mm (0.16 in.)	1 mm (0.04 in.)
Rear	7.5 mm (0.30 in.)	1 mm (0.04 in.)
Brake light timing:		
Front	Pulled ON	---
Rear	ON after about 10 mm (0.39 in.) of pedal travel	---
Electrical System:		
Spark plug	IZFR6F-11	---
Spark plug gap	1.0 ~ 1.1 mm (0.039 ~ 0.043 in.)	---

AT: Republic of Austria

CH: Swiss Confederation

DE: Federal Republic of Germany

Special Tools

Inside Circlip Pliers:
57001-143

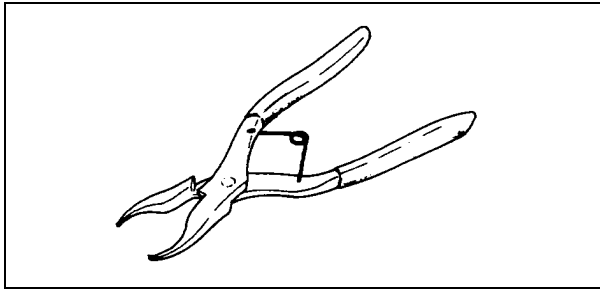

Spark Plug Wrench, Hex 16:
57001-1262

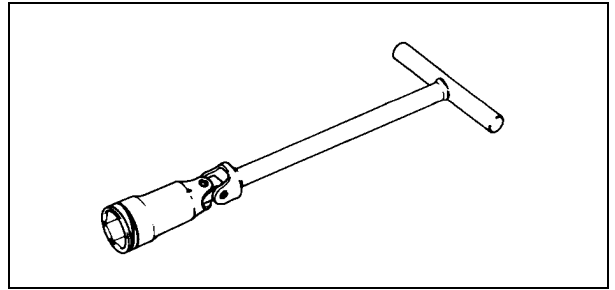

Steering Stem Nut Wrench:
57001-1100

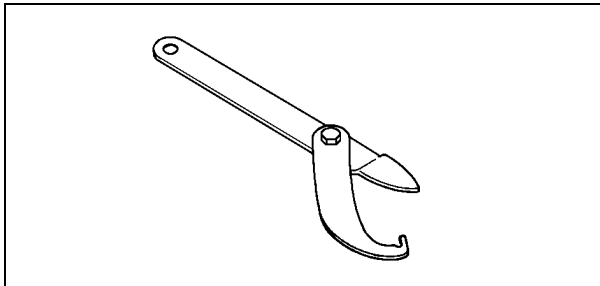

Jack Attachment :
57001-1571

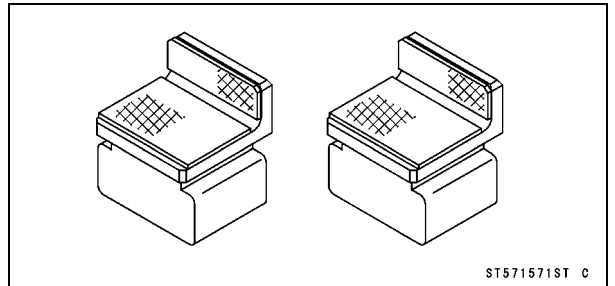

ST571571ST C

Jack:
57001-1238

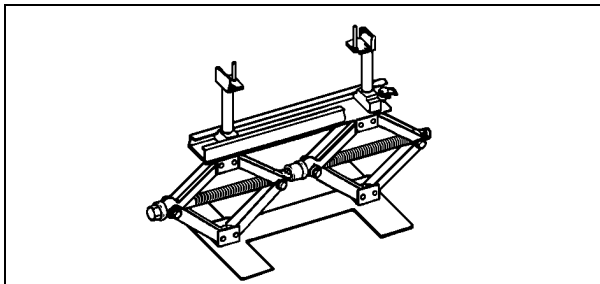

Drive Belt Tension Gauge:
57001- 1585

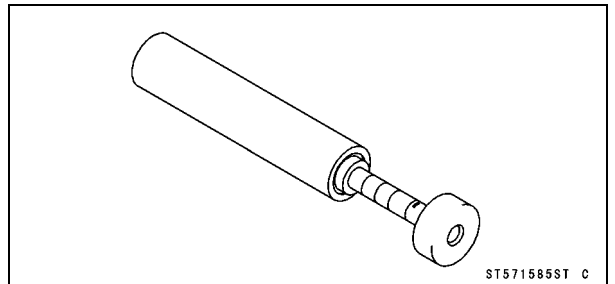

ST571585ST C

Oil Filter Wrench:
57001-1249

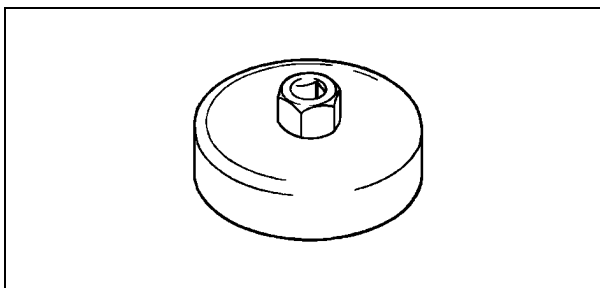

2-14 PERIODIC MAINTENANCE

Periodic Maintenance Procedures

Steering System:

Steering Play Inspection

- Check steering as follows.
- Use the jack [A] and jack attachment [B] under the frame pipe, and a commercially available jack [C] under the engine to lift the front wheel off the ground.

Special Tools - Jack: 57001-1238

Jack Attachment: 57001-1571

- With the front wheel pointing straight ahead, alternately tap each end of the handlebar. The front wheel should swing fully right and left from the force of gravity until the fork hits the stop.
- ★ If the wheel binds or catches before the stop, the steering is too tight.
- Feel for steering looseness by pushing and pulling [A] the fork.
- ★ If you feel looseness, the steering is too loose.

NOTE

- The cables and wiring will have some effect on the motion of the fork which must be taken into account. Be sure the wires and cables are properly routed.
- The bearings must be in good condition and properly lubricated in order for any test to be valid.

Steering Play Adjustment

- ★ Adjust the steering, if necessary.
- Remove:
 - Nacelle (see Frame chapter)
 - Handlebar (see Steering chapter)
 - Stem Head Nut [A]
 - Washer
- Loosen the upper fork clamp bolts on both sides.
- Remove:
 - O-ring [A]
 - Steering Stem Head [B]

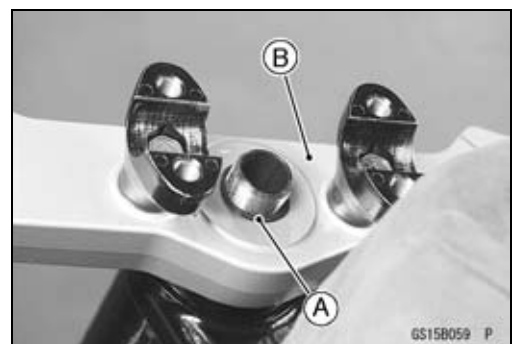
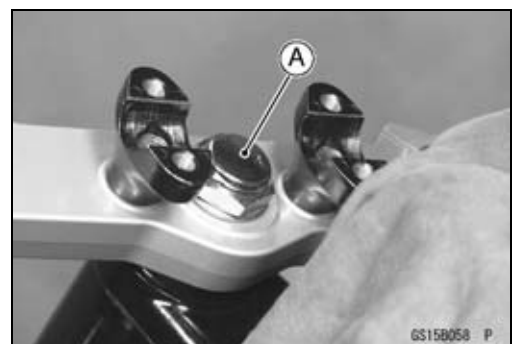
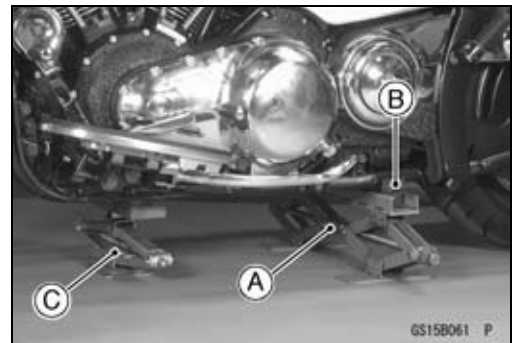

Periodic Maintenance Procedures

- Remove the claw washer.
- Adjust the stem nut [A] with the stem nut wrench [B] by tightening to the specified torque.

Special Tool - Steering Stem Nut Wrench: 57001-1100

Torque - Steering Stem Nut: 4.9 N·m (0.50 kgf·m, 43 in·lb)

- Install the stem head.
- Tighten the following in the order listed.

Torque - Stem Head Nut: 108 N·m (11 kgf·m, 80 ft·lb)

Upper Fork Clamp Bolts: 20 N·m (2.0 kgf·m, 15 in·lb)

- Run the throttle cables, brake hose, and clutch cable in accordance with the Cable, Wire, and Hose Routing section in the Appendix chapter.
- Check and adjust the steering and throttle cables after installation.

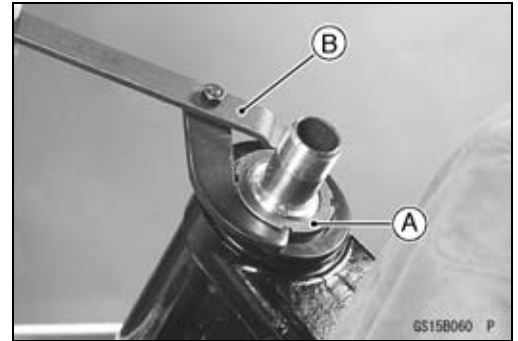

⚠ WARNING

Do not attempt to ride the motorcycle until a full brake lever is obtained by pumping the brake lever until the pads are against the disc. The brakes will not function on the first application of the lever if this is not done.

Steering Stem Bearing Lubrication

- Remove the steering stem. (see Steering chapter).
- Using a high-flash point solvent, wash the upper and lower tapered roller bearings [A] in the cages, and wipe the upper and lower outer races, which are press-fitted into the frame head pipe, clean of grease and dirt.
- Visually check the outer races and the rollers.
- ★ If the rollers or races are worn, or if either race is dented, replace both races and all the roller bearings as a set (see Steering chapter).
- Pack the upper and lower tapered roller in the cages with grease, and apply a light coat of grease to the upper and lower outer races.
- Install the steering stem, and adjust the steering (see Steering chapter).



Brake System:

Brake Fluid Leak (Brake Hose and Pipe)

- Apply the brake lever or pedal and inspect the brake fluid leak from the brake hoses [A] and fitting.
- ★ If the brake fluid leaked from any position, inspect or replace the problem part.

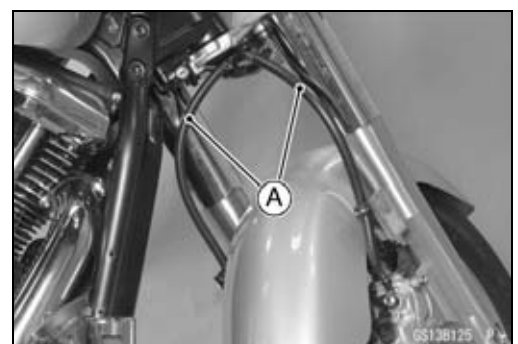

2-16 PERIODIC MAINTENANCE

Periodic Maintenance Procedures

Brake Hose Damage and Installation Connection Inspection

- Inspect the brake hose and fittings for deterioration, cracks and signs of leakage.
- The high pressure inside the brake line can cause fluid to leak [A] or the hose to burst if the line is not properly maintained. Bend and twist the rubber hose while examining it.
- ★ Replace the hose if any cracks [B], bulges [C] or leakage are noticed.
- ★ Tighten any banjo bolts.

Torque - Brake Hose Banjo Bolts: 25 N·m (2.5 kgf-m, 18 ft-lb)

- Inspect the brake hose routing.
- ★ If any brake hose routing is incorrect, route the brake hose according to Cable, Wire and Hose Routing section in the Appendix chapter.

Brake Operation Inspection

- Inspect the operation of the front and rear brake by running the vehicle on the dry road.
- ★ If the brake operation is insufficiency, inspect the brake system.

⚠ WARNING

When inspecting by running the vehicle, note a surrounding traffic situation enough in the place of safety.

Brake Fluid Level Inspection

- Check that the brake fluid level in the front brake reservoir [A] is above the lower level line [B].

NOTE

○ Hold the reservoir horizontal by turning the handlebar when checking brake fluid level.

- ★ If the fluid level is lower than the lower level line, fill the reservoir to the upper level line [A] in the reservoir [B].

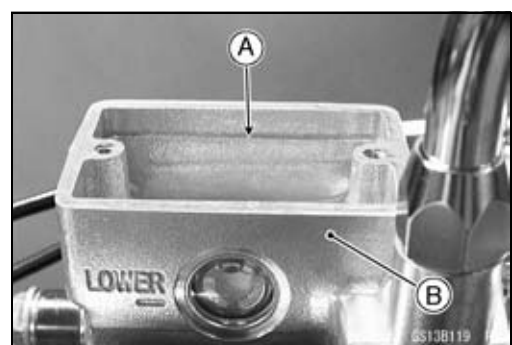
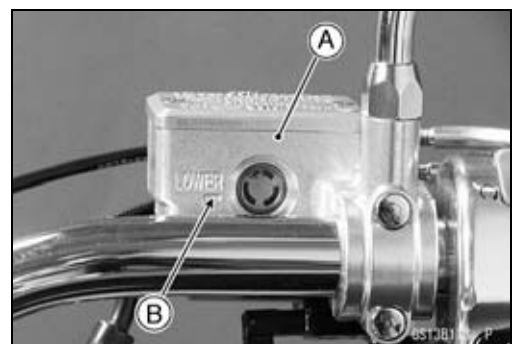
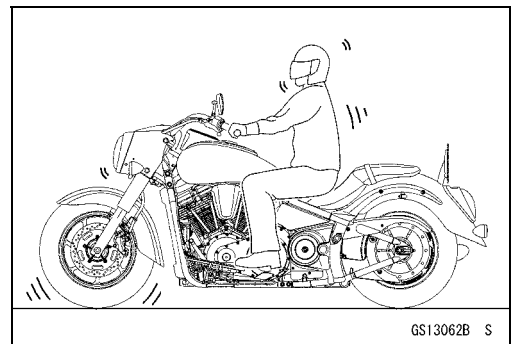
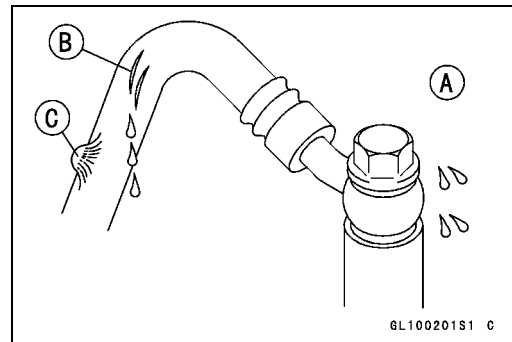

Periodic Maintenance Procedures

- Check that the brake fluid level in the rear brake reservoir [A] is between the upper [B] and the lower [C] level lines.
- ★ If the fluid level is lower than the lower level line, fill the reservoir to the upper level line.
- Use extra heavy-duty brake fluid only from a container marked DOT4.
- Brake fluid of DOT4 is installed in the brake system when shipped.

Torque - Front Brake Reservoir Cap Screws: 1.5 N·m (0.15 kgf·m, 13 in·lb)

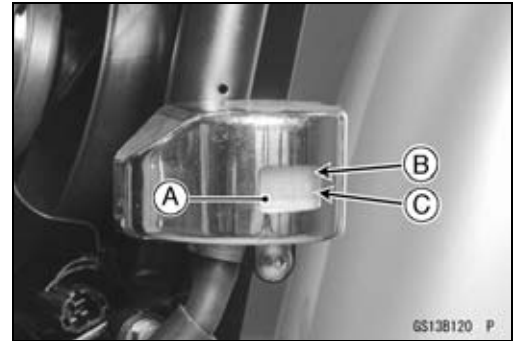

⚠ WARNING

Do not mix two brands of fluid. Change the brake fluid in the brake line completely if the brake fluid must be refilled but the type and brand of the brake fluid that is already in the reservoir are unidentified. After changing the fluid, use only the same type and brand of fluid thereafter.

Brake Pad Wear Inspection

- Check the lining thickness [A] of the pads in each caliper.
- ★ If the lining thickness of either pad is less than the service limit [B], replace both pads in the caliper as a set (see Brakes chapter).

Pad Lining Thickness

Standard:

Front: 4.0 mm (0.16 in.)

Rear: 7.5 mm (0.30 in.)

Service Limit: 1 mm (0.04 in.)

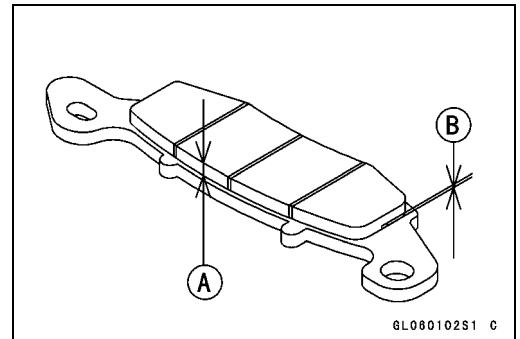

Brake Light Switch Operation

- Turn on the ignition switch.
- The brake light [A] should go on when the brake lever is applied or after the brake pedal is depressed about 10 mm (0.39 in.).



- ★ If it does not, adjust the brake light switch.
- While holding the switch body, turn the adjusting nut to adjust the switch.
 - Switch Body [A]
 - Adjusting Nut [B]
 - Light sooner as the body rises [C]
 - Light later as the body lowers [D]

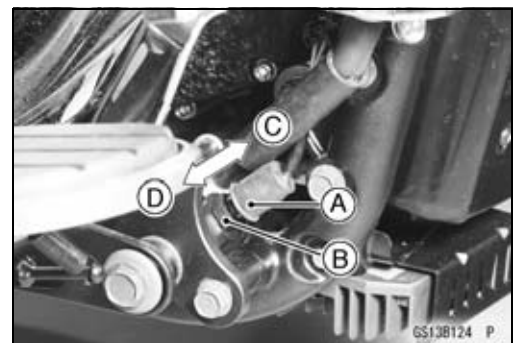

CAUTION

To avoid damaging the electrical connections inside the switch, be sure that the switch body does not turn during adjustment.

2-18 PERIODIC MAINTENANCE

Periodic Maintenance Procedures

- ★ If it does not go on, inspect or replace the following item.
 - Battery (see Electrical System chapter)
 - Brake Light Bulb (see Electrical System chapter)
 - Main Fuse 30 A and Taillight Fuse 10 A (see Electrical System chapter)
 - Front Brake Light Switch [A] (see Electrical System chapter)
 - Rear Brake Light Switch (see Electrical System chapter)
 - Harness (see Wiring Inspection in Electrical System chapter)

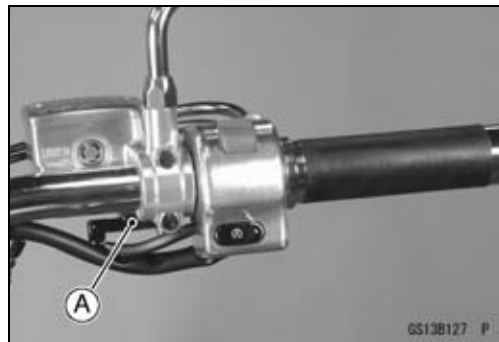

Wheel and Tires:

Tire Air Pressure Inspection

- Measure the tire air pressure with an air pressure gauge [A] when the tires are cold (that is, when the motorcycle has not been ridden more than a mile during the past 3 hours.)
- ★ Adjust the tire air pressure according to the specifications if necessary.

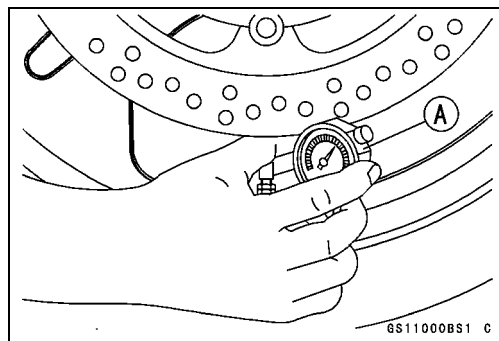

Air Pressure (when cold)

Front	Up to 186 kg (410 lb)	250 kPa (2.5 kgf/cm ² , 36 psi)
Rear	Up to 186 kg (410 lb)	290 kPa (3.0 kgf/cm ² , 42 psi)

⚠ WARNING

To ensure safe handling and stability, use only the recommended standard tires for replacement, inflated to the standard pressure. Use the same manufacturer's tires on both front and rear wheels.

NOTE

- Most countries may have their own regulations requiring a minimum tire tread depth; be sure to follow them.
- Check and balance the wheel when a tire is replaced with a new one (see *Wheels/Tires* chapter).

Wheel/Tire Damage Inspection

- Remove any imbedded stones [A] or other foreign particles [B] from tread.
- Visually inspect the tire for cracks and cuts replacing the tire in case of damage. Swelling or high spots indicate internal damage, requiring tire replacement.
- Visually inspect the wheel for cracks, cuts and dents damage.
- ★ If any damage is found, replace the wheel if necessary.



Tire Tread Wear Inspection

As the tire tread wears down, the tire becomes more susceptible to puncture and failure. An accepted estimate is that 90% of all tire failures occur during the last 10% of tread life (90% worn). So it is false economy and unsafe to use the tires until they are bald.

Periodic Maintenance Procedures

- Measure the tread depth at the center of the tread with a depth gauge [A]. Since the tire may wear unevenly, take measurement at several places.
- ★ If any measurement is less than the service limit, replace the tire (see *Wheels/Tires* chapter).

Tread Depth

Front:

- **Standard:** 4.3 mm (0.17 in.)
- **Service Limit:** 1 mm (0.04 in.)
(DE, AT, CH) 1.6 mm (0.063 in.)

Rear:

- **Standard:** 7.0 mm (0.28 in.)
- **Service Limit:** 2 mm (0.08 in.):
Up to 130 km/h (80 mph)
3 mm (0.1 in.):
Over to 130 km/h (80 mph)

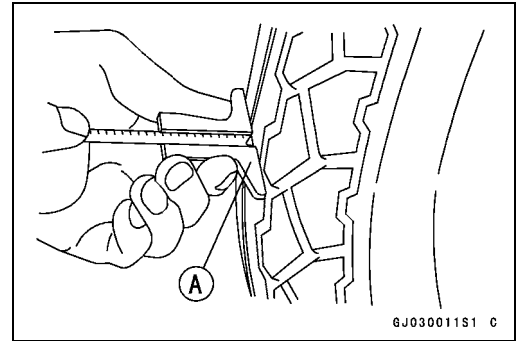

Wheel Bearing Damage Inspection

- Using a jack and attachment, raise the front wheel off the ground (see *Wheels/Tires* chapter).
- Turn the handlebar all the way to the right or left.
- Inspect the roughness of the front wheel bearing by pushing and pulling [A] the wheel.
- Spin [B] the front wheel lightly, and check for smoothly turn, roughness, binding or noise.
- ★ If roughness, binding or noise is found, remove the front wheel and inspect the wheel bearing (see *Wheels/Tires* chapter).



- Using a jack and attachment, raise the rear wheel off the ground (see *Wheels/Tires* chapter).
- Inspect the roughness of the rear wheel bearing by pushing and pulling [A] the wheel.
- Spin [B] the rear wheel lightly, and check for smoothly turn, roughness, binding or noise.
- ★ If roughness, binding or noise is found, remove the rear wheel and inspect the wheel bearing (see *Wheels/Tires* chapter) and coupling (see *Final Drive* chapter).

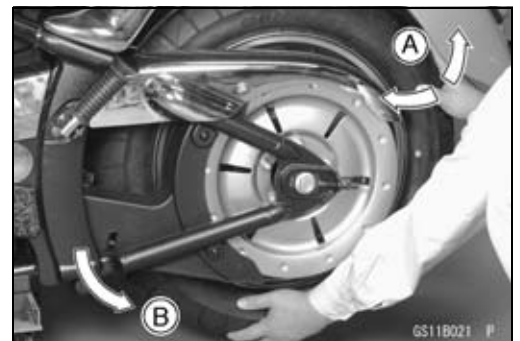

Suspensions

Front Forks/Rear Shock Absorber Operation Inspection

- Pump the forks down and up [A] 4 or 5 times, and inspect the smooth stroke.
- ★ If the forks do not smoothly or noise is found, inspect the fork oil level or fork clamps (see *Suspension* chapter).

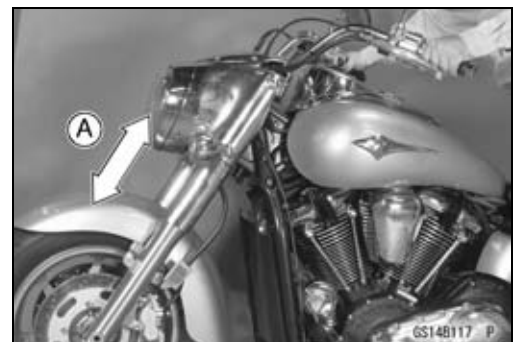

2-20 PERIODIC MAINTENANCE

Periodic Maintenance Procedures

- Pump the seat down and up [A] 4 or 5 times, and inspect the smooth stroke.
- ★ If the shock absorber does not smoothly or noise is found, inspect the oil leak (see Rear Shock Absorber Oil Leak Inspection) or shock absorber clamps (see Suspension chapter).



Front Fork Oil Leak Inspection

- Visually inspect the front forks [A] for oil leakage.
- ★ Replace or repair any defective parts, if necessary.

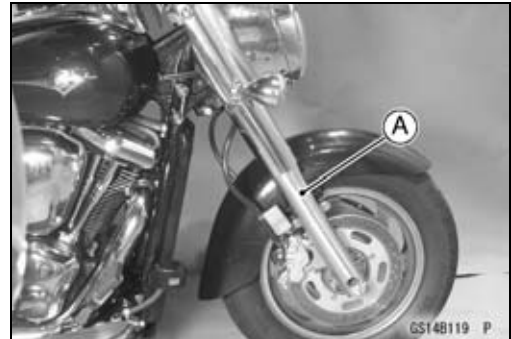

Rear Shock Absorber Oil Leak Inspection

- Remove:
 - Seats (see Frame chapter)
 - Battery Cover
- Visually inspect the shock absorber [A] for oil leakage.
- ★ If it is oil leaked, replace the shock absorber.

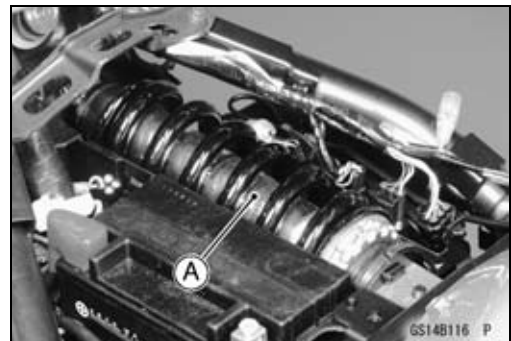

Swingarm Pivot Lubrication

- Remove the swingarm (see Suspension chapter).
- Clean the old grease out of the bearings.
- Apply grease to the inner surface of the needle bearings [A].
- Apply a thin coat of grease to the lips [B] of the grease seals.
- Install the swingarm (see Suspension chapter).

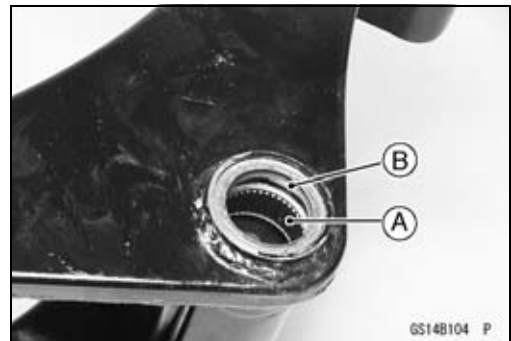

Periodic Maintenance Procedures

Clutch and Drive Train:

Clutch Operation

- Pull the clutch lever just enough to take up the free play [A].
- Measure the gap between the lever and the lever holder.
- ★ If the gap is too wide, the clutch may not release fully. If the gap is too narrow, the clutch may not engage fully. In either case, adjust it.

Clutch Lever Free Play

Standard: 2 ~ 3 mm (0.08 ~ 0.12 in.)



⚠ WARNING

To avoid a serious burn, never touch the or exhaust pipe during clutch adjustment.

- Loosen the locknut [A] at the clutch lever.
- Turn the adjuster [B] until the proper amount of clutch lever free play is obtained.
- Tighten the locknut securely.
- ★ If it cannot be done, use the adjuster at the middle of the cable.

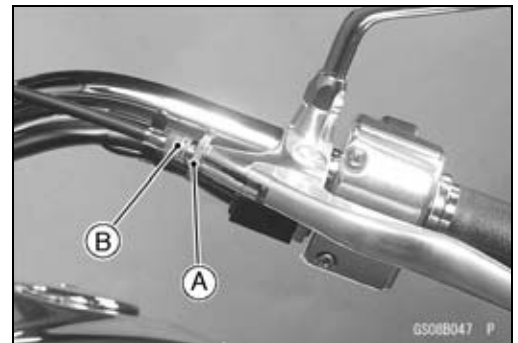

- Loosen the locknut [A] at the middle of the clutch cable.
- Turn the adjusting nut [B] until the proper amount of clutch lever free play is obtained.
- Tighten the locknut securely.

⚠ WARNING

Be sure that the outer cable end at the clutch lever is fully seated in the adjuster at the clutch lever, or it could slip into place later, creating enough cable play to prevent clutch disengagement.

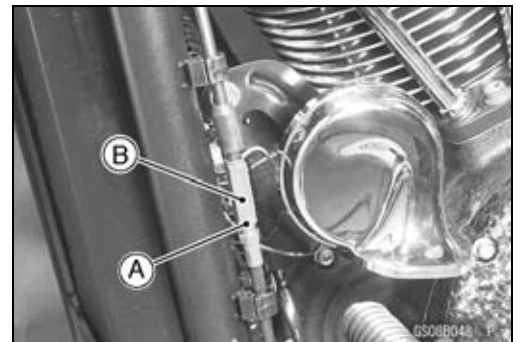

- After the adjustment, start the engine and check that the clutch does not slip and that it releases properly.

Belt Deflection Inspection

NOTE

- Belt deflection must be checked and adjusted when the belt is cold (at room temperature).
- Belt deflection also should be checked at first 1000 km ride after belt replacement.

- Check to see if wheel alignment is properly adjusted.
- The left and right notches on the belt adjuster should point to the same marks or positions on the swingarm.
- ★ If they do not, adjust wheel alignment (see Wheel Alignment Inspection/Adjustment).

2-22 PERIODIC MAINTENANCE

Periodic Maintenance Procedures

- Using the jack and jack attachment under the frame pipe ribs, lift the rear wheel off the ground (see Rear Wheel Removal in the Wheels/Tires chapter).
- Visually inspect the belt for damage (see Belt Wear and Damage Inspection).
- ★ If the belt is damaged, replace it with a new one.
- Mark the initial belt position [C] on the belt cover window.
- Using the tension gauge [A], push up 45 N (4.5 kgf, 10 lb) of force from under and on the center of the belt at the gauge of the lower belt cover [B].
- Measure the deflection (length between mark [D] and [C]) of the belt.

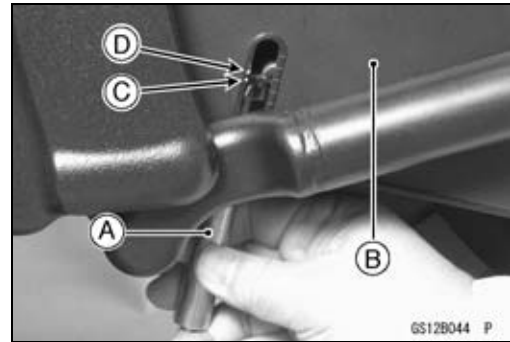

NOTE

- Push the belt by the gauge until the top surface [A] of the stopper comes to the 45 N loaded scale [B], marked "45N".
- Push up on the center of the belt. An inaccurate reading will occur if the edge of the belt is pushed up.
- Look parallel to the belt during inspection. An inaccurate reading will occur if looking from any other angle.
- Inspect the belt deflection at two positions by rotating the rear wheel.

Special Tools - Drive Belt Tension Gauge: 57001-1585

- Inspect the drive belt deflection at arbitrary position, and record the value [A].

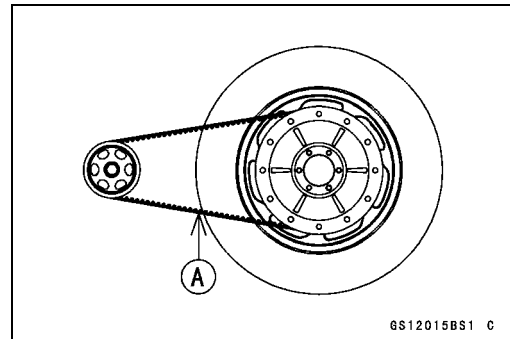
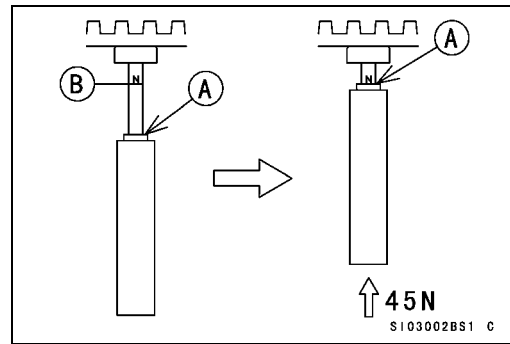

- Turn the rear wheel 90 degrees.

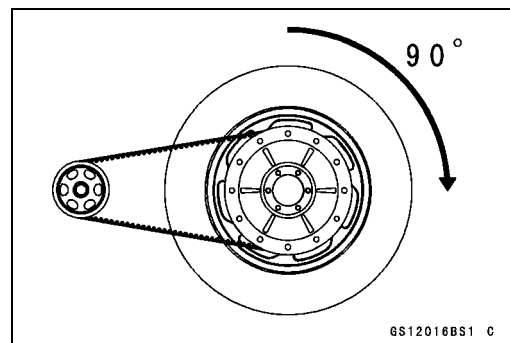

Periodic Maintenance Procedures

- Inspect the drive belt deflection, and record the value [B].

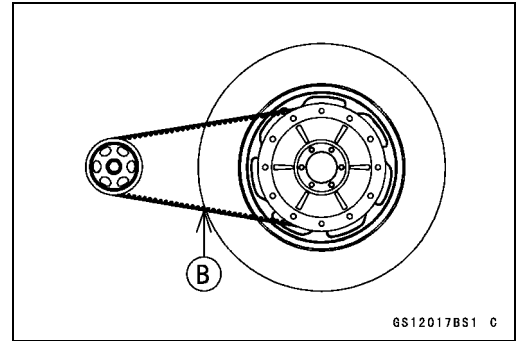

- Decide the belt deflection at the position [C] of one where deflection is large.

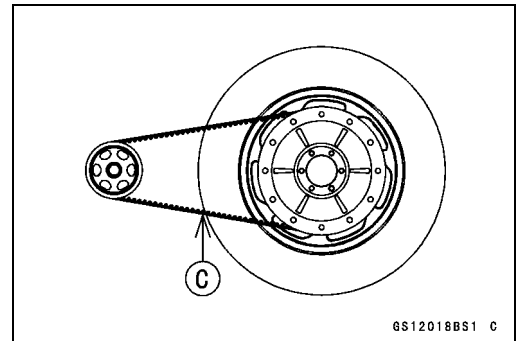

Drive Belt Deflection (with 45 N, 4.5 kgf, 10 lb force)

Standard: 2.5 ~ 4.0 mm (0.10 ~ 0.16 in.)

Drive Belt Deflection (with 45 N, 4.5 kgf, 10 lb force, when installing new belt or engine remounted)

Standard: 2.5 mm (0.10 in.)

★If the deflection is out of the specification, adjust it.

Belt Deflection Adjustment

- Remove:
 - Muffler Body (see Engine Top End chapter)
 - Upper Belt Cover
- Remove the axle cotter pin, and loosen the axle nut.
- Using the jack and jack attachment under the frame pipe ribs, lift the rear wheel off the ground (see Rear Wheel Removal in the Wheels/Tires chapter).

- Loosen the left and right belt adjuster locknuts [A].
- ★If the belt is too tight, back out the left and right belt adjuster nuts [B], and kick the wheel forward until the belt is too loose.
- Turn in the left and right belt adjuster nuts evenly until the drive belt has the correct amount of deflection.
- To keep the belt and wheel aligned, the notch on the left belt adjuster should align with the same swingarm mark [C] that the right belt adjuster notch aligns with.

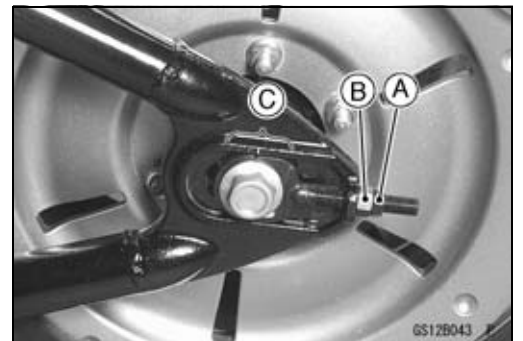

2-24 PERIODIC MAINTENANCE

Periodic Maintenance Procedures

- Tighten both belt adjuster locknuts.

⚠ WARNING

Misalignment of the wheel will result in abnormal wear, and may result in an unsafe riding condition. Tighten both belt adjuster locknuts, and make sure the axle stays aligned.

- Tighten the axle nut.
Torque - Rear Axle Nut: 108 N·m (11 kgf·m, 80 ft·lb)
- Inspect the drive belt deflection (see Drive Belt Deflection Inspection).
- ★ Readjust if necessary.
- Insert a new cotter pin [A].

NOTE

- When inserting the cotter pin, if the slots in the nut do not align with the cotter pin hole in the axle, tighten the nut clockwise [B] up to next alignment.
- It should be within 30 degree.
- Loosen once and tighten again when the slot goes past the nearest hole.

- Bend the cotter pin [A] over the nut.

⚠ WARNING

If the rear axle nut is not securely tightened or the cotter pin is not installed, an unsafe riding condition may result.

- Check the rear brake for weak braking power and brake drag.

Wheel Alignment Inspection/Adjustment

- Check that the notch [A] on the left belt adjuster [B] aligns with the same swingarm mark [C] or position that the right belt adjuster notch aligns with.
- ★ If they do not, adjust the belt deflection (see Belt Deflection Adjustment) and align the wheel alignment.

NOTE

- Wheel alignment can be also checked using the straightedge or string method.

⚠ WARNING

Misalignment of the wheel will result in abnormal wear, and may result in an unsafe riding condition.

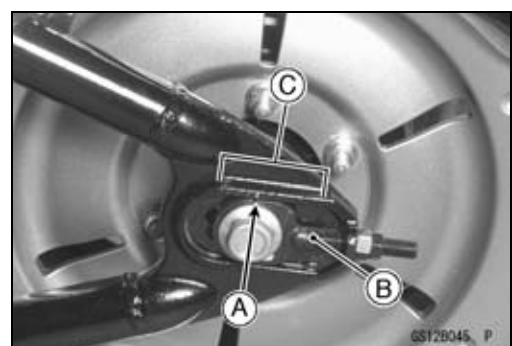
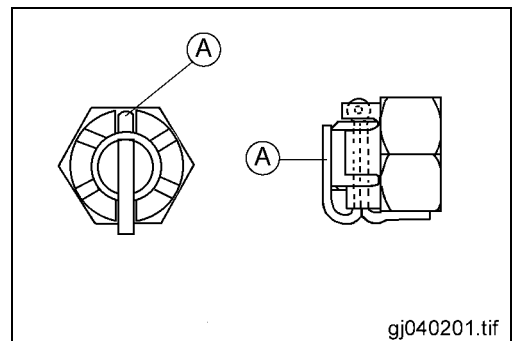
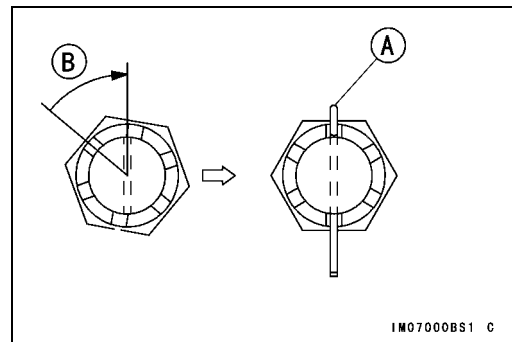

Periodic Maintenance Procedures

Belt Wear and Damage Inspection

- Using the jack and jack attachment under the frame pipe ribs, lift the rear wheel off the ground (see Rear Wheel Removal in the Wheels/Tires chapter).

- Remove:
 - Bolts [A] and Washers
 - Upper Belt Cover [B]

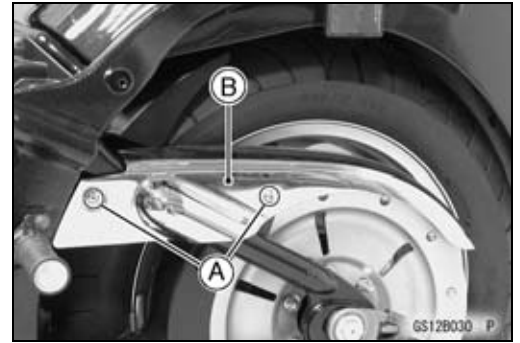

- Visually inspect the belt [A] for wear and damage.
- ★ If the nylon fabric facing of any portion is worn off, and the polyurethane compound is exposed, or belt is damaged, replace the belt immediately with a new one.
- Otherwise, refer to the Drive Belt Tooth Wear Patterns and perform the according to the table of Drive Belt Wear Analysis.
- ★ Whenever the belt is replaced, inspect the engine and rear pulleys (see Pulley Wear Inspection in Final Drive chapter).

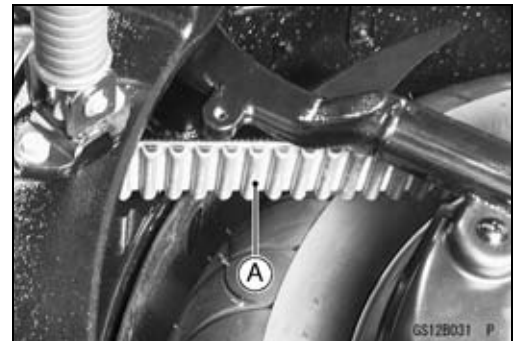

⚠ WARNING

A belt worn past the nylon fabric facing must be replaced. Such a worn belt may cause a serious accident.

2-26 PERIODIC MAINTENANCE

Periodic Maintenance Procedures

Drive Belt Tooth Wear and Damage Patterns

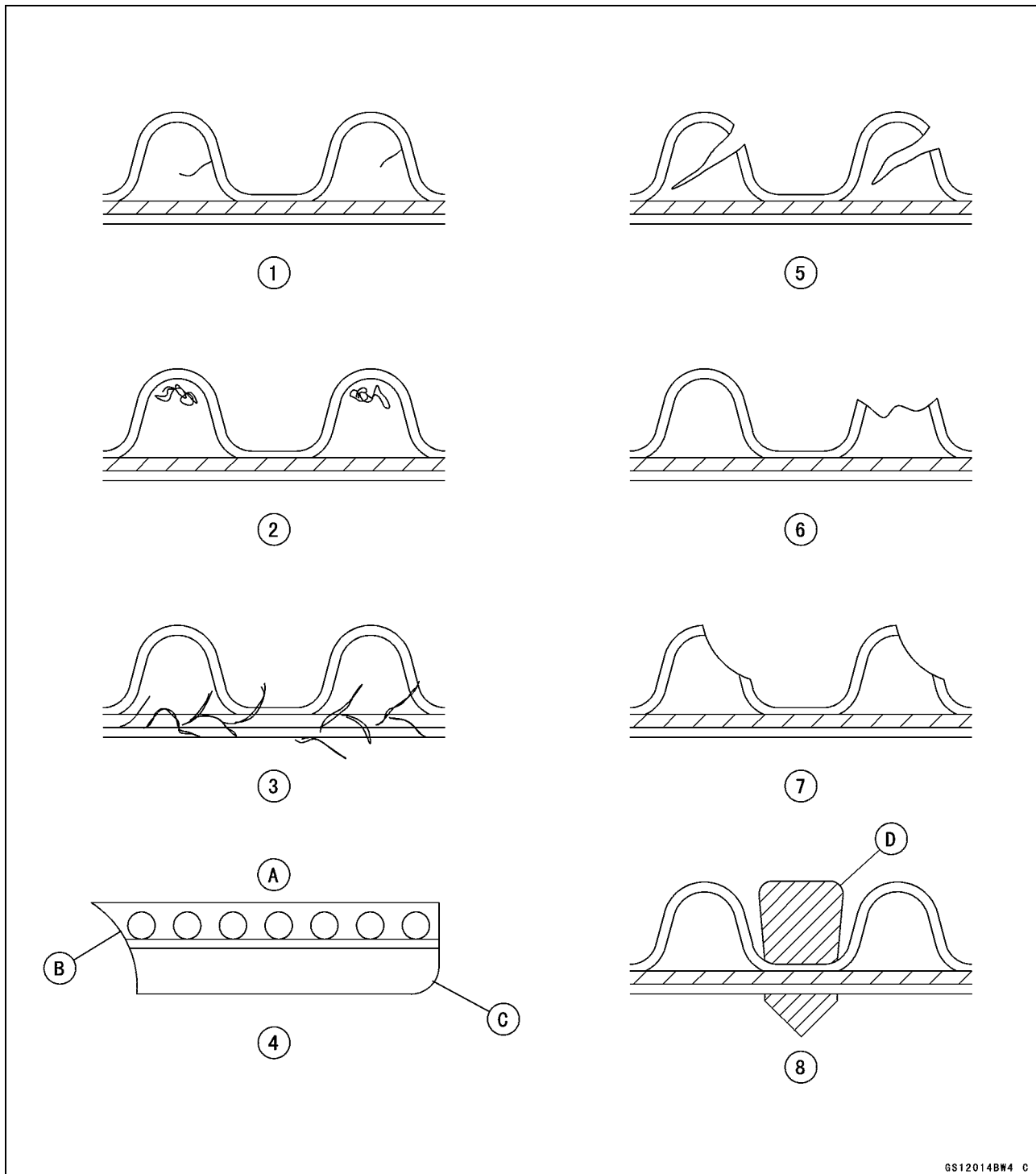

- A. Belt Cross Section
- B. Edge Bevel Wear
- C. Rub Wear
- D. Stone

Periodic Maintenance Procedures

Drive Belt Wear and Damage Analysis

Pattern	Condition	Required Action
1	Internal tooth cracks (slight)	O.K. for continued use, but inspect the belt periodically.
2	Scuffing to side of teeth	O.K. for continued use, but inspect the belt periodically. Also check the pulley flange.
3	Fraying edge cord	O.K. for continued use, but inspect the belt periodically (replace the belt if excessive).
4	Beveled wear	O.K. for continued use, check the pulley alignment and flange condition.
5	External tooth cracks (severe)	Replace the drive belt.
6	Severe fractured or missing teeth	Replace the drive belt.
7	Tooth hook wear	Replace the drive belt. Inspect the pulley for wear.
8	Stone damage	Remove stone, O.K. for continued use if not near edge of the belt. Inspect the pulley for damage.

Electrical System:

Spark Plug Condition Inspection

- Visually inspect the spark plugs.
- ★ If the spark plug center electrode [A] and/or side electrode [B] are corroded or damaged, or if the insulator [C] is cracked, replace the plug.
- ★ If the spark plug is dirtied or the carbon is accumulated, replace the spark plug.
- Measure the gap [D] with a wire-type thickness gauge.
- ★ If the gap is incorrect, replace the spark plug.

Spark Plug Gap: 1.0 ~ 1.1 mm (0.039 ~ 0.043 in.)

- Use the standard spark plug or its equivalent.

Spark Plug : IZFR6F-11

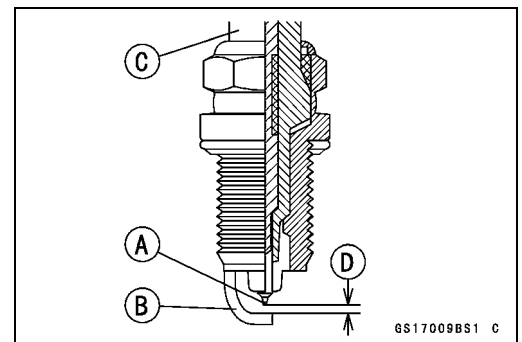

2-28 PERIODIC MAINTENANCE

Periodic Maintenance Procedures

Lights and Switches Operation

First Step:

- Turn on the ignition switch.
- The following lights should go on according to below table.

Models	Position Lights [A]	City Light [B]	Tail-light [C]	Li- cense Plate Light [D]	Neutral Indicator light [E] in meter unit
United States	go on	—	goes on	goes on	goes on
Canada	go on	—	goes on	goes on	goes on
Europe	—	goes on	goes on	goes on	goes on
Australia	—	—	goes on	goes on	goes on
Malaysia	—	—	goes on	goes on	goes on

★ If the light does not go on, inspect or replace the following item.

- Battery (see Electrical System chapter)
- Applicable Bulb (see Electrical System chapter)
- Main Fuse 30 A and Taillight Fuse 10 A (see Electrical System chapter)
- Ignition Switch (see Electrical System chapter)
- Gear Position Switch (for neutral indicator light, see Electrical System chapter)
- Harness (see Wiring Inspection in Electrical System chapter)

- Turn off the ignition switch.
- The all lights should go off.
- ★ If the light does not go off, replace the ignition switch.

Second Step:

- Turn the ignition switch to P (Park) position.
- The taillight and license plate light should go on.
- ★ If the light does not go on, inspect or replace the following item.
 - Ignition Switch (see Electrical System chapter)

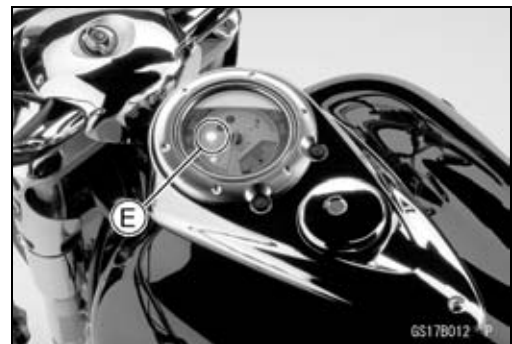
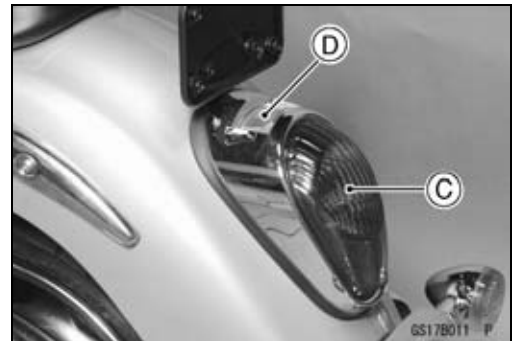
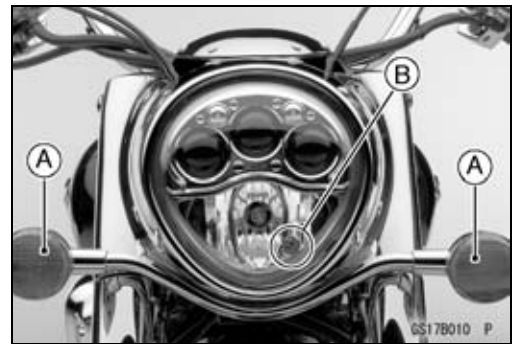

Periodic Maintenance Procedures

Third Step:

- Turn on the turn signal switch [A] (left or right position).
- The left or right turn signal lights [B] (front and rear) according to the switch position should flash.
- The turn signal indicator light [C] in the meter unit should flash.

★If the each light does not flash, inspect or replace the following item.

- Turn Signal Light Bulb (see Electrical System chapter)
- Turn Signal Light Indicator Bulb (see Electrical System chapter)
- Turn Signal Control Relay Fuse 10 A (see Electrical System chapter)
- Turn Signal Switch (see Electrical System chapter)
- Turn Signal Control Relay (see Electrical System chapter)
- Harness (see Wiring Inspection in Electrical System chapter)

- Push the turn signal switch.
 - The turn signal lights and indicator light should go off.
- ★If the light does not go off, inspect or replace the following item.

- Turn Signal Switch (see Electrical System chapter)
- Turn Signal Control Relay (see Electrical System chapter)

NOTE

○Refer to *Electrical system chapter for the automatic turn signal canceling system.*

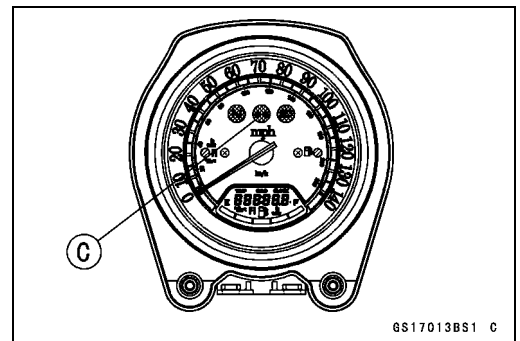
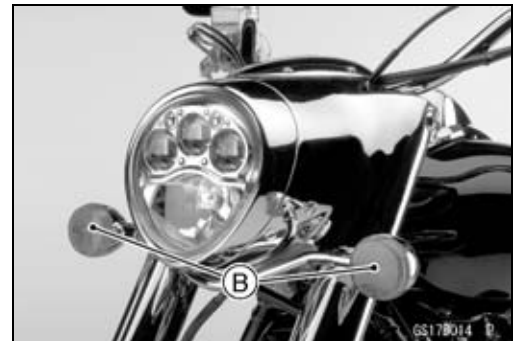
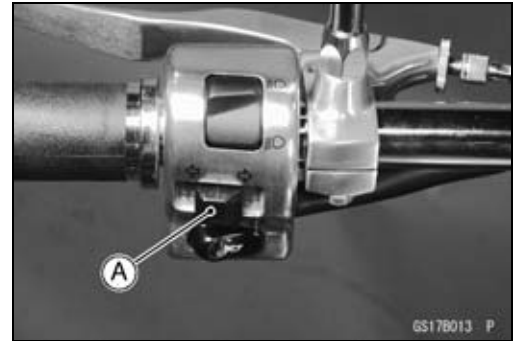

Fourth Step:

- Set the dimmer switch [A] to low beam position.
 - Start the engine.
 - The low beam headlight should go on.
- ★If the low beam headlight does not go on, inspect or replace the following item.

- Headlight Low Beam Bulb (see Electrical System chapter)
- Headlight Fuse 10 A (see Electrical System chapter)
- Dimmer Switch (see Electrical System chapter)
- Headlight Relay in Relay Box (see Electrical System chapter)
- Harness (see Wiring Inspection in Electrical System chapter)

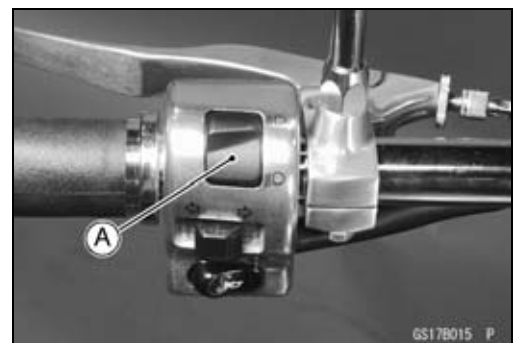

2-30 PERIODIC MAINTENANCE

Periodic Maintenance Procedures

- Set the dimmer switch to high beam position.
- The low beam [A] and high beam [B] headlights should go on.
- The high beam indicator light [C] should go on.
- ★ If the high beam headlight and/or high beam indicator light does not go on, inspect or replace the following item.
 - Headlight High Beam Bulb (see Electrical System chapter)
 - Dimmer Switch (see Electrical System chapter)
- Turn off the engine stop switch.
- The low beam and high beam headlights should stay going on.
- ★ If the headlights and high beam indicator light does go off, inspect or replace the following item.
 - Headlight Relay in Relay Box (see Electrical System chapter)
- Turn off the ignition switch.
- The headlights and high beam indicator light should go off.

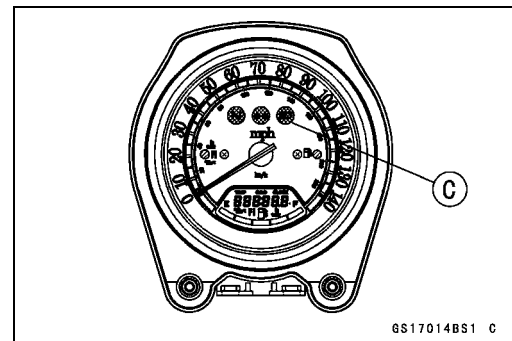
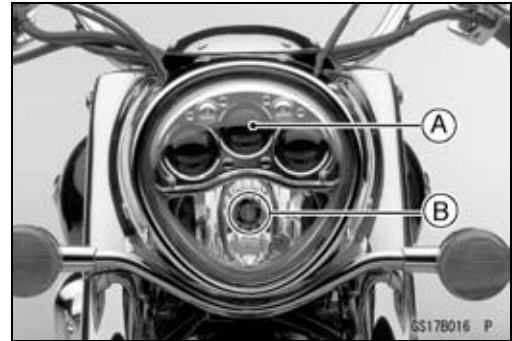

Headlight Aiming Inspection

- Inspect the headlight beam for aiming.
- ★ If the headlight beam points to one side rather than straight ahead, adjust the horizontal beam.

Headlight Beam Horizontal Adjustment

- Remove the cap [A].
- Turn the horizontal adjuster on the headlight with a screwdriver in or out until the beam points straight ahead.
- Turn the adjuster clockwise to face the headlight to the left.



- ★ If the headlight beam points too low or high, adjust the vertical beam.

Headlight Beam Vertical Adjustment

- Remove the cap [A].
- Turn the vertical adjuster [A] in the headlight in or out with a screwdriver to adjust the headlight vertically.
- Turn the adjuster clockwise to face the headlight up.



Periodic Maintenance Procedures

NOTE

- ON high beam, the brightest points should be slightly below horizontal with the motorcycle on its wheels and the rider seated. Adjust the headlight to the proper angle according to local regulations.
- For US model, the proper angle is 0.4 degrees below horizontal. This is 50 mm (2 in.) drop at 7.6 m (25 ft.) measured from the center of the headlight with the motorcycle on its wheels and the rider seated.

50 mm (2 in.) [A]
 Center of Brightest Spot [B]
 7.6 m (25 ft.) [C]

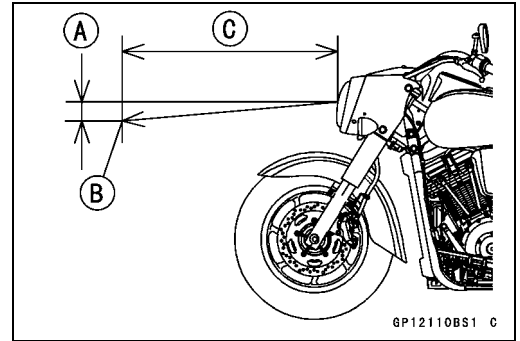

Side Stand Switch Operation Inspection

- Inspect the side stand switch [A] operation accordance to below table.

Sidestand Switch Operation

Side Stand	Gear Position	Clutch Lever	Engine Start	Engine Run
Up	Neutral	Re-leased	Starts	Continue running
Up	Neutral	Pulled in	Starts	Continue running
Up	In Gear	Re-leased	Doesn't start	Continue running
Up	In Gear	Pulled in	Starts	Continue running
Down	Neutral	Re-leased	Starts	Continue running
Down	Neutral	Pulled in	Starts	Continue running
Down	In Gear	Re-leased	Doesn't start	Stops
Down	In Gear	Pulled in	Doesn't start	Stops

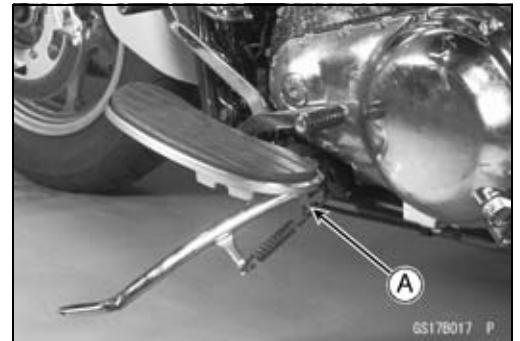

★ If the side stand switch operation does not work, inspect or replace the following item.

- Battery (see Electrical System chapter)
- Main Fuse 30 A (see Electrical System chapter)
- Ignition Fuse 10 A (see Electrical System chapter)
- Ignition Switch (see Electrical System chapter)
- Side Stand Switch (see Electrical System chapter)
- Engine Stop Switch (see Electrical System chapter)
- Starter Button (see Electrical System chapter)
- Gear Position Switch (see Electrical System chapter)
- Starter Control Relay (see Electrical System chapter)
- Relay Box (see Electrical System chapter)
- Starter Control Relay (see Electrical System chapter)
- Harness (see Wiring Inspection in Electrical System chapter)

★ If the all parts are good condition, replace the ECU.



Download the full PDF manual instantly.

Our customer service e-mail:

aservicemanualpdf@yahoo.com