

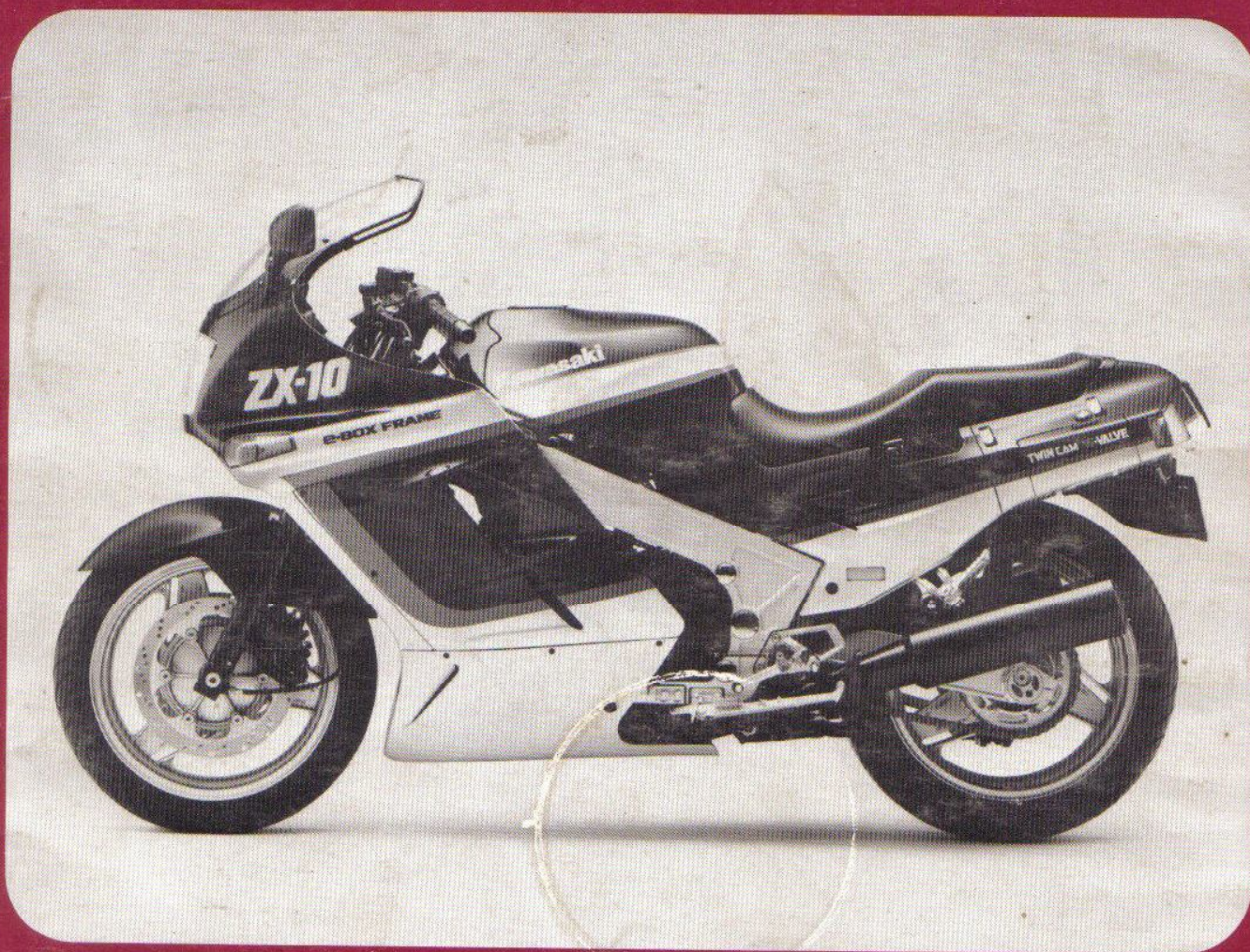

Kawasaki

NinjaZX-10
ZX-10



1988-90

Motorcycle
Service Manual

MODEL APPLICATION

Year	Model	Beginning Frame No.
1988	ZX1000-B1	JKAZXCB1□JA000001 or ZXT00B-000001 or 012452
1989	ZX1000-B2	JKAZXCB1□KA012001 or 017001 or ZXT00B-012001 or 017001
1990	ZX1000-B3	JKAZXCB1□LA028001 or ZXT00B-028001

□ : This digit in the frame number changes from one machine to another.

KAWASAKI
HEAVY INDUSTRIES, LTD.
CONSUMER PRODUCTS & COMPONENTS GROUP

Part No. 99924-1098-02

Printed in Japan.

Quick Reference Guide

General Information	1
Fuel System	2
Cooling System	3
Engine Top End	4
Clutch	5
Engine Lubrication System	6
Engine Removal/Installation	7
Crankshaft/Transmission	8
Wheels/Tires	9
Final Drive	10
Brakes	11
Suspension	12
Steering	13
Frame	14
Electrical System	15
Appendix	16

This quick reference guide will assist you in locating a desired topic or procedure.

- Bend the pages back to match the black tab of the desired chapter number with the black tab on the edge at each table of contents page.

- Refer to the sectional table of contents for the exact pages to locate the specific topic required.

Wiring Diagrams

LIST OF ABBREVIATIONS

A	ampere(s)	lb	pound(s)
ABDC	after bottom dead center	m	meter(s)
AC	alternating current	min	minute(s)
ATDC	after top dead center	N	newton(s)
BBDC	before bottom dead center	Pa	pascal(s)
BDC	bottom dead center	PS	horsepower
BTDC	before top dead center	psi	pound(s) per square inch
°C	degree(s) Celcius	r	revolution
DC	direct current	rpm	revolution(s) per minute
F	farad(s)	TDC	top dead center
°F	degree(s) Fahrenheit	TIR	total indicator reading
ft	foot, feet	V	volt(s)
g	gram(s)	W	watt(s)
h	hour(s)	Ω	ohm(s)
L	liter(s)		

This warning may apply to any of the following components or any assembly containing one or more of these components:—



Brake Shoes or Pads
Clutch Friction Material
Gaskets
Insulators

SAFETY INSTRUCTIONS

- Operate if possible out of doors or in a well ventilated place.
- Preferably use hand tools or low speed tools equipped, if necessary, with an appropriate dust extraction facility. If high speed tools are used, they should always be so equipped.
- If possible, dampen before cutting or drilling.
- Dampen dust and place it in properly closed receptacle and dispose of it safely.

Read OWNER'S MANUAL before operating

Foreword

This manual is designed primarily for use by trained mechanics in a properly equipped shop. However, it contains enough detail and basic information to make it useful to the owner who desires to perform his own basic maintenance and repair work. A basic knowledge of mechanics, the proper use of tools, and workshop procedures must be understood in order to carry out maintenance and repair satisfactorily. Whenever the owner has insufficient experience or doubts his ability to do the work, all adjustments, maintenance, and repair should be carried out only by qualified mechanics.

In order to perform the work efficiently and to avoid costly mistakes, read the text, thoroughly familiarize yourself with the procedures before starting work, and then do the work carefully in a clean area. Whenever special tools or equipment are specified, do not use makeshift tools or equipment. Precision measurements can only be made if the proper instruments are used, and the use of substitute tools may adversely affect safe operation.

For the duration of your warranty period, especially, we recommend that all repairs and scheduled maintenance be performed in accordance with this service manual. Any owner maintenance or repair procedure not performed in accordance with this manual may void the warranty.

To get the longest life out of your Motorcycle:

- Follow the Periodic Maintenance Chart in the Service Manual.
- Be alert for problems and non-scheduled maintenance.
- Use proper tools and genuine Kawasaki Motorcycle parts. Special tools, gauges, and testers that are necessary when servicing Kawasaki motorcycles are introduced by the Special Tool Manual. Genuine parts provided as spare parts are listed in the Parts Catalog.
- Follow the procedures in this manual carefully. Don't take shortcuts.
- Remember to keep complete records of maintenance and repair with dates and any new parts installed.

How to Use this Manual

In preparing this manual, we divided the product into its major systems. These systems became the manual's chapters. All information for a particular system from adjustment through disassembly and inspection is located in a single chapter.

The Quick Reference Guide shows you all of the product's system and assists in locating their chapters. Each chapter in turn has its own comprehensive Table of Contents.

The Periodic Maintenance Chart is located in the General Information chapter. The chart gives a time schedule for required maintenance operations.

If you want spark plug information, for example, go to the Periodic Maintenance Chart first. The chart tells you how frequently to clean and gap the plug. Next, use the Quick Reference Guide to locate the Electrical System chapter. Then, use the Table of Contents on the first page of the chapter to find the Spark Plug section.

Whenever you see these WARNING and CAUTION symbols, heed their instructions! Always follow safe operating and maintenance practices.

WARNING

- This warning symbol identifies special instructions or procedures which, if not correctly followed, could result in personal injury, or loss of life.

CAUTION

- This caution symbol identifies special instructions or procedures which, if not strictly observed, could result in damage to or destruction of equipment.

This manual contains five more symbols (in addition to WARNING and CAUTION) which will help you distinguish different types of information.

NOTE

- This note symbol indicates points of particular interest for more efficient and convenient operation.

- Indicates a procedural step or work to be done.
- Indicates a procedural sub-step or how to do the work of the procedural step it follows. It also precedes the text of a WARNING, CAUTION, or NOTE.
- ★ Indicates a conditional step or what action to take based on the results of the test or inspection in the procedural step or sub-step it follows.
- ☆ Indicates a conditional sub-step or what action to take based upon the results of the conditional step it follows.

In most chapters an exploded view illustration of the system components follows the Table of Contents. In these illustrations you will find the instructions indicating which parts require specified tightening torque, oil, grease or a locking agent during assembly.

WARNING

CAUTION

NOTE

General Information

Table of Contents

Before Servicing	1-2
Model Identification	1-4
General Specifications	1-5
Periodic Maintenance Chart	1-8
Torque and Locking Agent	1-10
Cable, Wire and Hose Routing	1-14

1-2 GENERAL INFORMATION

Before Servicing

Before starting to service a motorcycle, careful reading of the applicable section is recommended to eliminate unnecessary work. Photographs, diagrams, notes, cautions, warnings, and detailed descriptions have been included wherever necessary. Nevertheless, even a detailed account has limitations, a certain amount of basic knowledge is also required for successful work.

Especially note the following:

- (1) **Dirt**

Before removal and disassembly, clean the motorcycle. Any dirt entering the engine or other parts will work as an abrasive and shorten the life of the motorcycle. For the same reason, before installing a new part, clean off any dust or metal filings.
- (2) **Battery Ground**

Remove the ground (—) lead from the battery before performing any disassembly operations on the motorcycle. This prevents:

 - (a) the possibility of accidentally turning the engine over while partially disassembled.
 - (b) sparks at electrical connections which will occur when they are disconnected.
 - (c) damage to electrical parts.
- (3) **Tightening Sequence**

Generally, when installing a part with several bolts, nuts, or screws, they should all be started in their holes and tightened to a snug fit. Then tighten them evenly in a cross pattern. This is to avoid distortion of the part and/or causing gas or oil leakage. Conversely when loosening the bolts, nuts, or screws, first loosen all of them by about a quarter of turn and then remove them. Where there is a tightening sequence indication in this Service Manual, the bolts, nuts, or screws must be tightened in the order and method indicated.
- (4) **Torque**

The torque values given in this Service Manual should always be adhered to. Either too little or too much torque may lead to serious damage. Use a good quality, reliable torque wrench.
- (5) **Force**

Common sense should dictate how much force is necessary in assembly and disassembly. If a part seems especially difficult to remove or install, stop and examine what may be causing the problem. Whenever tapping is necessary, tap lightly using a wooden or plastic faced mallet. Use an impact driver for screws (particularly for the removal of screws held by a locking agent) in order to avoid damaging the screw heads.
- (6) **Edges**

Watch for sharp edges, especially during major engine disassembly and assembly. Protect your hands with gloves or a piece of thick cloth when lifting the engine or turning it over.
- (7) **High Flash-point Solvent**

A high flash-point solvent is recommended to reduce fire danger. A commercial solvent commonly available in North America is Stoddard solvent (generic name). Always follow manufacturer and container directions regarding the use of any solvent.
- (8) **Gasket, O-ring**

Do not reuse a gasket or O-ring once it has been in service. The mating surfaces around the gasket should be free of foreign matter and perfectly smooth to avoid oil or compression leaks.
- (9) **Liquid Gasket, Non-permanent Locking Agent**

Follow manufacturer's directions for cleaning and preparing surfaces where these compounds will be used. Apply sparingly. Excessive amounts may block engine oil passages and cause serious damage. An example of a non-permanent locking agent commonly available in North America is Loctite Lock'n Seal (Blue).
- (10) **Press**

A part installed using a press or driver, such as a wheel bearing, should first be coated with oil on its outer or inner circumference so that it will go into place smoothly.
- (11) **Ball Bearing**

When installing a ball bearing, the bearing race which is affected by friction should be pushed by a suitable driver. This prevents severe stress on the balls and races, and prevents races and balls from being dented. Press a ball bearing until it stops at the stop in the hole or on the shaft.

(12) Oil Seal and Grease Seal

Replace any oil or grease seals that were removed with new ones, as removal generally damages seals.

When pressing in a seal which has manufacturer's marks, press it in with the marks facing out. Seals should be pressed into place using a suitable driver, which contacts evenly with the side of seal, until the face of the seal is even with the end of the hole.

(13) Seal Guide

A seal guide is required for certain oil or grease seals during installation to avoid damage to the seal lips. Before a shaft passes through a seal, apply a little oil, preferably high temperature grease on the lips to reduce rubber to metal friction.

(14) Circlip, Retaining Ring

Replace any circlips and retaining rings that were removed with new ones, as removal weakens and deforms them. When installing circlips and retaining rings, take care to compress or expand them only enough to install them and no more.

(15) Lubrication

Engine wear is generally at its maximum while the engine is warming up and before all the rubbing surfaces have an adequate lubricative film. During assembly, oil or grease (whichever is more suitable) should be applied to any rubbing surface which has lost its lubricative film. Old grease and dirty oil should be cleaned off. Deteriorated grease has lost its lubricative quality and may contain abrasive foreign particles.

Don't use just any oil or grease. Some oils and greases in particular should be used only in certain applications and may be harmful if used in an application for which they are not intended. This manual makes reference to molybdenum disulfide grease (MoS₂) in the assembly of certain engine and chassis parts. Always check manufacturer recommendations before using such special lubricants.

(16) Electrical Wires

All the electrical wires are either single-color or two-color and, with only a few exceptions, must be connected to wires of the same color. On any of the two-color wires there is a greater amount of one color and a lesser amount of a second color, so a two-color wire is identified by first the primary color and then the secondary color. For example, a yellow wire with thin red stripes is referred to as a "yellow/red" wire; it would be a "red/yellow" wire if the colors were reversed to make red the main color.

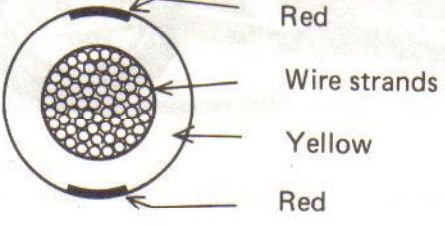
Wire (cross-section)	Name of Wire Color
	<p style="text-align: center;">Yellow/red</p>

(17) Replacement Parts

When there is a replacement instruction, replace these parts with new ones every time they are removed. These replacement parts will be damaged or lose their original function once removed.

(18) Inspection

When parts have been disassembled, visually inspect these parts for the following conditions or other damage. If there is any doubt as to the condition of them, replace them with new ones.

- | | | | |
|--------------|---------------|-----------|------|
| Abrasion | Crack | Hardening | Warp |
| Bent | Dent | Scratch | Wear |
| Color change | Deterioration | Seizure | |

(19) Service Data

Numbers of service data in this text have following meanings:

- "Standards": Show dimensions or performances which brand-new parts or systems have.
- "Service limits": Indicate the usable limits. If the measurement shows excessive wear or deteriorated performance, replace the damaged parts.

1-4 GENERAL INFORMATION

Model Identification

ZX1000-B1



ZX1000-B2



ZX1000-B3



General Specifications

Item	ZX1000-B1/B2	ZX1000-B3
Dimensions:		
Overall length	2 170 mm, (G) (N) (S) (Sw) (W) 2 200 mm	←
Overall width	715 mm	←
Overall height	1 240 mm	←
Wheelbase	1 490 mm	←
Road clearance	125 mm	←
Seat height	790 mm	←
Dry weight	222 kg, (Cal) 222.5 kg	←
Curb weight: Front	126 kg, (Cal) 126.5 kg	←
Rear	128 kg	←
Fuel tank capacity	22.0 L	←
Performance:		
Climbing ability	30°	←
Braking distance	12.5 m from 50 km/h	←
Minimum turning radius	3.1 m	← Climbing ability
Engine:		
Type	4-stroke, DOHC, 4-cylinder	←
Cooling system	Liquid-cooled	←
Bore and stroke	74.0 x 58.0 mm	←
Displacement	997 mL	←
Compression ratio	11.0, (F) 10.2	←
Maximum horsepower	Max: 101 kW (137 PS) @10 000 r/min (rpm), (AS) (Sw) 73.6 kW (100 PS) @8 800 r/min (rpm), (UK) 91.9 kW (125 PS) @10 000 r/min (rpm) (ISO4106), (S) 53.0 kW (72 PS) @6 000 r/min (rpm), (W) 73.6 kW (100 PS) @8 800 r/min (rpm)(DIN), (F) 75.1 kW (—) @8 800 r/min (rpm) (UTAC'S norm)	← (Sw) 65.5 kW (89 PS) @9 000 r/min (rpm), ← (W) 73.6 kW (100 PS) @9 000 r/min (rpm)(DIN), ← (E) 99.3 kW (135 PS) @10 000 r/min (rpm)
Maximum torque	103 N-m (10.5 kg-m, 76 ft-lb) @9 000 r/min (rpm), (S) 85 N-m (8.7 kg-m, 63 ft-lb) @6 000 r/min (rpm), (AS) (Sw) 89 N-m (9.1 kg-m, 66 ft-lb) @6 800 r/min (rpm), (F) (UK) — (W) 89 N-m (9.1 kg-m, 66 ft-lb) @6 800 r/min (rpm) (DIN)	← (Sw) 82 N-m (8.4 kg-m, 61 ft-lb) @6 000 r/min (rpm), ← (W) 85 N-m (8.7 kg-m, 63 ft-lb) @6 500 r/min (rpm)(DIN), ← (E) 102 N-m (10.4 kg-m, 75 ft-lb) @9 000 r/min (rpm)
Carburetor system	Carburetors, Keihin CVKD36 x 4	←
Starting system	Electric starter	←
Ignition system	Battery and coil (transistorized)	←

1-6 GENERAL INFORMATION

Items	ZX1000-B1/B2/B3
Timing advance	Electronically advanced
Ignition timing	From 10° BTDC @1 000 r/min (rpm) to 35° BTDC @7 500 r/min (rpm) (S) From 10° BTDC @1 200 r/min (rpm) to 35° BTDC @7 500 r/min (rpm)
Spark plug	NGK CR9E or ND U27ESR-N (U)(A)(I)(SA) NGK C9E or ND U27ES-N
Cylinder numbering method	Left to right, 1-2-3-4
Firing order	1-2-4-3
Valve timing:	
Inlet	Open 38° BTDC, (F) 20° BTDC
	Close 68° ABDC, (F) 50° ABDC
	Duration 286°, (F) 250°
Exhaust	Open 60° BBDC, (F) 45° BBDC
	Close 40° ATDC, (F) 25° ATDC
	Duration 280°, (F) 250°
Lubrication system	Forced lubrication (wet sump with cooler)
Engine oil:	
Grade	SE or SF class
Viscosity	SAE10W40, 10W50, 20W40, or 20W50
Capacity	4.0 L
Drive Train:	
Primary reduction system:	
Type	Gear
Reduction ratio	1.732 (97/56)
Clutch type	Wet multi disc
Transmission:	
Type	6-speed, constant mesh, return shift
Gear ratios: 1st	2.800 (42/15)
2nd	2.000 (38/19)
3rd	1.590 (35/22)
4th	1.333 (32/24)
5th	1.153 (30/26)
6th	1.035 (29/28)
Final drive system:	
Type	Chain drive
Reduction ratio	2.647 (45/17)
Overall drive ratio	4.748

GENERAL INFORMATION 1-7

Items	ZX1000-B1/B2/B3
Frame:	
Type	Tubular, double cradle
Caster (rake angle)	26.5°
Trail	101 mm
Front tire:	
Type	Tubeless
Size	120/70VR17-V280, 120/70VB17-V280 or 120/70 ZR17
Rear tire:	
Type	Tubeless
Size	160/60VR18-V280, 160/60VB18-V280 or 160/60 ZR18
Front suspension:	
Type	Telescopic fork
Wheel travel	135 mm
Rear suspension:	
Type	Swing arm (uni-trak)
Wheel travel	120 mm
Brake type:	
Front	Dual disc
Rear	Single disc
Electrical Equipment:	
Battery	12 V 14 Ah
Headlight:	
Type	Semi-sealed beam
Bulb	12 V 60/55 W (quartz-halogen)
Tail/brake light	12 V 5/21 W x 2, (SA) (U) (C) 12 V 8/27 W x 2
Alternator:	
Type	Three-phase AC
Rated output	24 A @6 000 r/min (rpm), 14 V
Voltage regulator:	
Type	Short-circuit

Specifications subject to change without notice, and may not apply to every country.

(A) : Australian Model

(C) : Canadian Model

(Cal) : Californian Model

(S) : Swiss Model

(SA) : South African Model

(U) : US Model

(Sw) : Swedish Model

(W) : West German Model

(UK) : UK Model

(F) : French Model

(G) : Greek Model

(N) : Norwegian Model

(AS) : Austrian Model

(I) : Italian Model

(E) : European Model

1-8 GENERAL INFORMATION

Periodic Maintenance Chart

The scheduled maintenance must be done in accordance with this chart to keep the motorcycle in good running condition. **The initial maintenance is vitally important and must not be neglected.**

OPERATION	FREQUENCY	*ODOMETER READING						
		800 km	5,000 km	10,000 km	15,000 km	20,000 km	25,000 km	30,000 km
	Whichever comes first	→						
	Every	↓						
Spark plug – clean		•	•	•	•	•	•	•
Spark plug – check †		•	•	•	•	•	•	•
Valve clearance – check †		•	•	•	•	•	•	•
Air suction valve (US),(S) – check †		•	•	•	•	•	•	•
Air cleaner element – clean		•	•				•	
Air cleaner element – replace	5 cleanings				•			
Throttle grip play – check †		•	•	•	•	•	•	•
Idle speed – check †		•	•	•	•	•	•	•
Engine vacuum synchronization – check †		•	•	•	•	•	•	•
Fuel system – check †			•		•		•	
Coolant – change	2 years						•	
Evaporative emission control system (Cal) – check †		•	•	•	•	•	•	•
Engine oil – change	year	•	•	•	•	•	•	•
Oil filter – replace		•	•	•	•	•	•	•
Radiator hoses, connections – check †	year	•	•	•	•	•	•	•
Fuel Filter – replace			•	•		•		
Fuel hose – replace	4 years							
Clutch fluid level – check †	month	•	•	•	•	•	•	•
Clutch fluid – change	2 years				•			
Clutch hose and pipe – replace	4 years							
Clutch master cylinder cup and dust seal – replace	2 years							
Clutch slave cylinder piston seal – replace	2 years							
Drive chain wear – check †		•	•	•	•	•	•	•
Drive chain – lubricate	300 km							
Drive chain slack – check †	800 km							
Brake pad wear – check †		•	•	•	•	•	•	•
Brake fluid level – check †	month	•	•	•	•	•	•	•
Brake fluid – change	2 years				•			
Brake hose – replace	4 years							

GENERAL INFORMATION 1-9

OPERATION	FREQUENCY	*ODOMETER READING						
	Every	800 km	5,000 km	10,000 km	15,000 km	20,000 km	25,000 km	30,000 km
Brake master cylinder cup and dust seal — replace	2 years							
Caliper piston seal and dust seal — replace	2 years							
Brake light switch — check †		•	•	•	•	•	•	•
Steering — check †		•	•	•	•	•	•	•
Steering stem bearing — lubricate	2 years				•			
Front fork oil — change							•	
Tire wear — check †			•	•	•	•	•	
Swing arm pivot, uni-trak linkage — lubricate				•	•		•	
Battery electrolyte level — check †	month	•	•	•	•	•	•	•
General lubrication — perform			•	•	•	•	•	•
Nut, bolt, and fastener tightness — check †		•	•	•	•	•	•	•
Coolant filter (UK) — clean †	year							

* : For higher odometer readings, repeat at the frequency interval established here.

† : Replace, add, adjust, clean, or torque if necessary.

(Cal): California vehicle only

(US): US only

(S) : Swiss only

(UK): UK only

1-10 GENERAL INFORMATION

Torque and Locking Agent

The following tables list the tightening torque for the major fasteners requiring use of a non-permanent locking agent or liquid gasket.

Letters used in the "Remarks" column mean:

L : Apply a non-permanent locking agent to the threads.

LG : Apply liquid-gasket to the threads.

O : Apply an oil to the threads and seated surface.

S : Tighten the fasteners following the specified sequence.

St : Stake the fasteners to prevent loosening.

SS : Apply silicon sealant

Fastener	Torque			Remarks
	N-m	kg-m	ft-lb	
Cooling System:				
Fan Switch	18	1.8	13.0	
Water Temperature Sensor	15	1.5	11.0	SS
Bleeder Bolt	7.8	0.80	69 in-lb	
Drain Plug	7.8	0.80	69 in-lb	
Engine Top End:				
Cylinder Head Cover Bolts	9.8	1.0	87 in-lb	
Upper Chain Guide Mounting Bolts	—	—	—	L
Rear Chain Guide Mounting Bolt	20	2.0	14.5	L
Chain Tensioner Mounting Bolts	9.8	1.0	87 in-lb	
Camshaft Sprocket Bolts	15	1.5	11.0	L
Rocker Shaft End Cap	25	2.5	18.0	
Main Oil Hose Banjo Bolts	25	2.5	18.0	
Camshaft Cap Bolts	12	1.2	104 in-lb	S
Cylinder Head Bolts (10 mm Dia.)	39	4.0	29	S
Cylinder Head Bolts (11 mm Dia.)	51	5.2	38	S
Cylinder Head Bolt (6 mm Dia.)	9.8	1.0	87 in-lb	S
Cylinder Bolts	15	1.5	11.0	
Clutch:				
Clutch Hose Banjo Bolts	25	2.5	18	
Clutch Slave Cylinder Mounting Bolts	—	—	—	L
Clutch Master Cylinder Clamp Bolts	11	1.1	95 in-lb	
Clutch Hose Joint	18	1.8	13.0	
Clutch Slave Cylinder Bleeder Bolt	7.8	0.80	69 in-lb	
Clutch Spring Bolts	9.8	1.0	87 in-lb	
Clutch Hub Nut	130	13.5	98	
Right Cover Bolts	—	—	—	L (*1)
Right Cover Damper Bolts	9.8	1.0	87 in-lb	L

GENERAL INFORMATION 1-11

Fastener	Torque			Remarks
	N-m	kg-m	ft-lb	
Wheels/Tires:				
Front Axle Nut	88	9.0	65	
Front Axle Clamp Bolts	20	2.0	14.5	
Tire Air Valve Nuts	1.5	0.15	13 in-lb	
Rear Axle Nut	108	11.0	80	
Final Drive:				
Engine Sprocket Nut	98	10.0	72	
Rear Sprocket Nuts	74	7.5	54	
Brakes:				
Front Brake Reservoir Cap Screws	1.5	0.15	13 in-lb	
Brake Lever Pivot Nut	5.9	0.60	52 in-lb	
Front Master Cylinder Clamp Bolts	11	1.1	95 in-lb	S
Brake Hose Banjo Bolts	25	2.5	18	
Bleed Valves	7.8	0.80	69 in-lb	
Caliper Mounting Bolts	34	3.5	25	
Disc Mounting Bolts: Front	34	3.5	25	
Rear	23	2.3	16.5	
Torque Link Bolt/Nut	25	2.5	18.0	
Brake Pedal Mounting Bolt	8.8	0.9	78 in-lb	
Suspension:				
Front Fork:				
Top Plugs	23	2.3	16.5	
Fork Clamp Bolts	28	2.9	21	
Drain Screws	1.5	0.15	13 in-lb	LG
Bottom Allen Bolts	39	4.0	29	L
Axle Clamp Bolts	21	2.1	15.0	
Rear Shock Absorber:				
Damper Adjuster Cable End	8.8	0.90	78 in-lb	
Air Valve Hose End	12	1.2	104 in-lb	
Shock Absorber Nuts	59	6.0	43	
Rocker Arm Nut	59	6.0	43	
Tie-Rod Nuts	59	6.0	43	
Swing Arm Pivot Shaft Nut	88	9.0	65	
Chain Adjuster Clamp Bolts	39	4.0	29	
Steering:				
Steering Stem Head Nut	39	4.0	29	
Steering Stem Nut	4.9	0.50	43 in-lb	
Handlebar Holder Mounting Bolts	20	2.0	14.5	

1-12 GENERAL INFORMATION

Fastener	Torque			Remarks
	N-m	kg-m	ft-lb	
Engine Lubrication System:				
Oil Passage Plug	18	1.8	13.0	
Drain Plug	18	1.8	13.0	
Crankcase Outside Oil Pipe Banjo Bolts	18	1.8	13.0	
Oil Pump Gear Holder Screws	—	—	—	L
Oil Pump Mounting Bolts	12	1.2	104 in-lb	L
Oil Pump Relief Valve	—	—	—	L
Main Oil Pipe Banjo Bolts	25	2.5	18.0	
Oil Pressure Switch	15	1.5	11.0	SS
Oil Pan Bolts	—	—	—	L (*2)
Oil Cooler Pipe				
Banjo Bolts (Oil cooler side)	25	2.5	18.0	
Oil Cooler Pipe				
Banjo Bolts (Oil pan side)	34	3.5	25	
Oil Filter Bolt	20	2.0	14.5	
Engine Removal/Installation:				
Engine Mounting Nuts	44	4.5	33	
Down Tube Mounting Bolts	44	4.5	33	
Crankshaft/Transmission:				
Conneting Rod Big End Cap Nuts	—	—	—	(*3)
Alternator Shaft Left End Bolt	25	2.5	18.0	
Alternator Coupling Bolt	9.8	1.0	87 in-lb	
Alternator Coupling Nut	59	6.0	43	
Alternator Shaft Chain Tensioner				
Mounting Bolts	—	—	—	L
Alternator Shaft Chain Guide Bolts	—	—	—	L
Alternator Shaft Chain Sprocket Bolts	25	2.5	18.0	
One-way Clutch Bolts	12	1.2	104 in-lb	L
Balancer Shaft Guide Pin Plate Bolt	—	—	—	L
Crankshaft Main Bearing Cap Bolts	27	2.8	20	
Crankcase Bolts (6 mm Dia.)	15	1.5	11.0	
Crankcase Bolts (8 mm Dia.)	27	2.8	20	
Shift Drum Bearing Holder Allen Bolts	—	—	—	L
Shift Drum Pin Plate Screw	—	—	—	L
External Shift Mechanism Return				
Spring Pin	—	—	—	L
External Shiaft Mecahnism Cover Screws	—	—	—	L
Neutral Switch	15	1.5	11.0	

GENERAL INFORMATION 1-13

Fastener	Torque			Remarks
	N-m	kg-m	ft-lb	
Electrical System:				
Alternator Mounting Bolts	25	2.5	18.0	L
Alternator Coupling Brades Bolt	9.8	1.0	87 in-lb	
Pickup Coil Mounting Bolts	—	—	—	L
Pickup Coil Cover Bolts	—	—	—	L (*4)
Spark Plugs	14	1.4	10.0	
Timing Rotor Bolt	25	2.5	18.0	
Alternator Cover Cap Nut	4.9	0.50	43	

- (*1): See Clutch chapter
- (*2): See Engine Lubrication chapter
- (*3): See Crankshaft/Transmission chapter
- (*4): See Electrical System chapter

1-14 GENERAL INFORMATION

Cable, Wire and Hose Routing

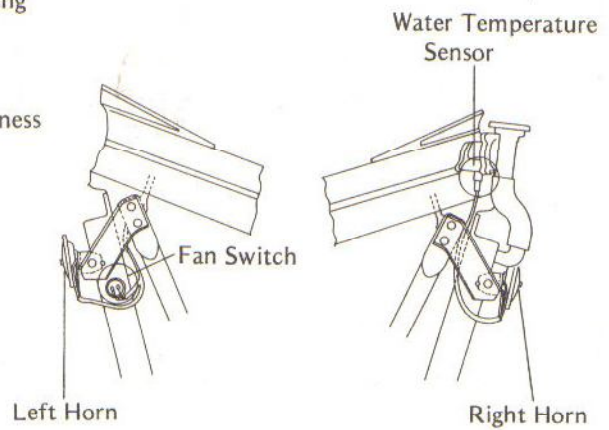
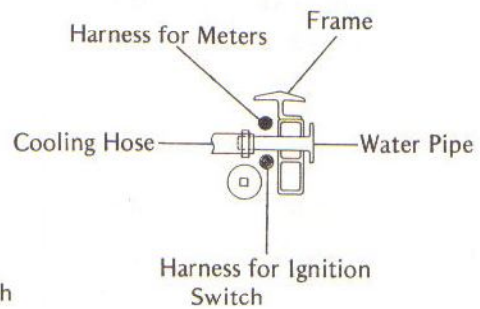
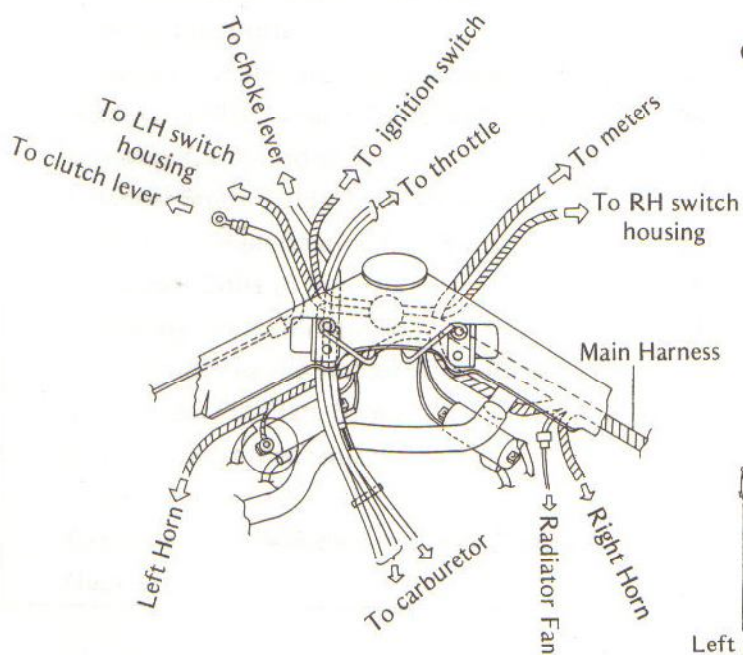
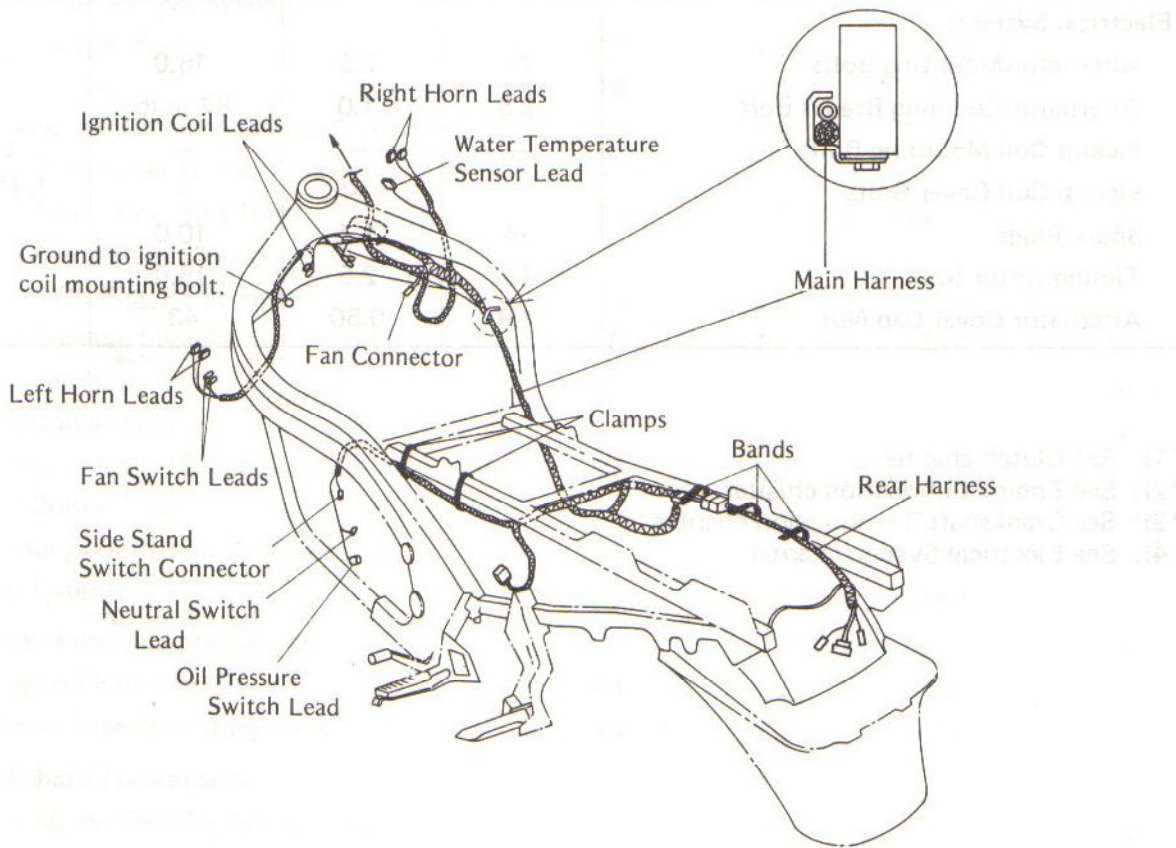

GENERAL INFORMATION 1-15

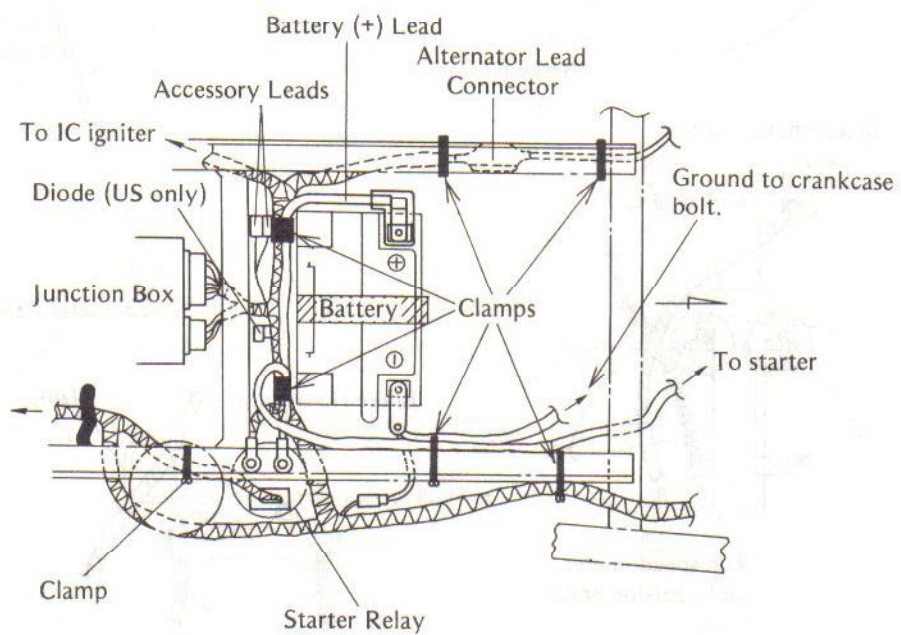
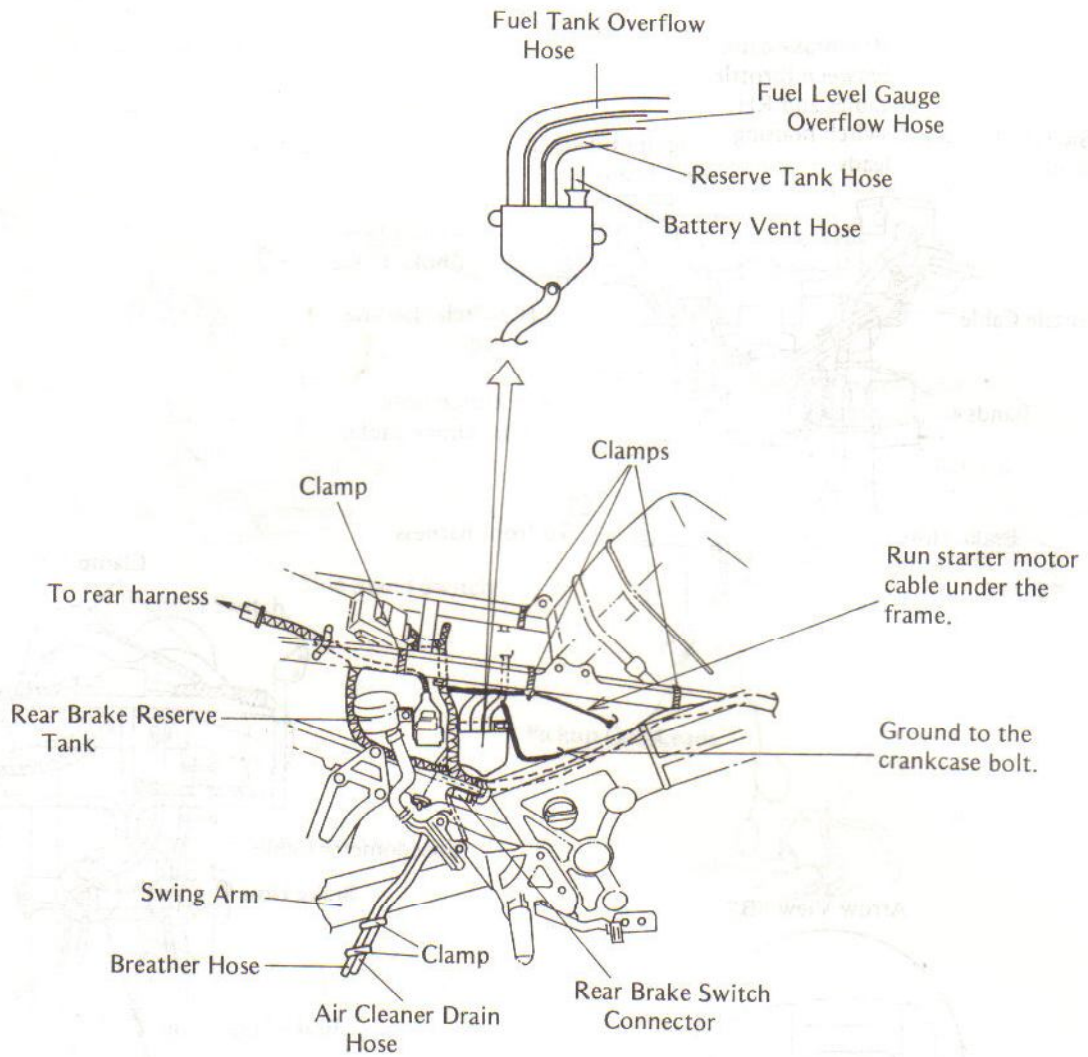

1-16 GENERAL INFORMATION

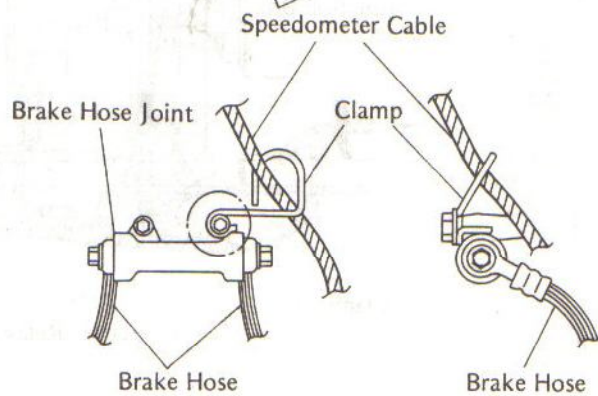
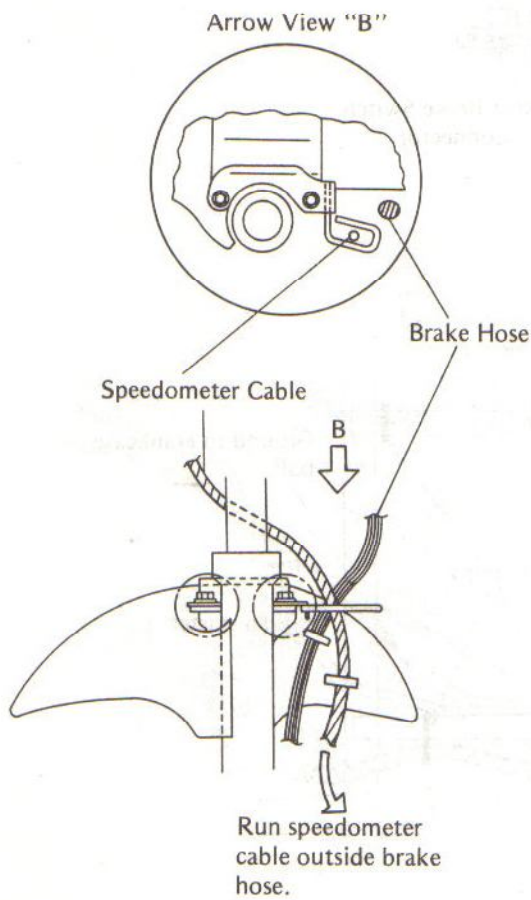
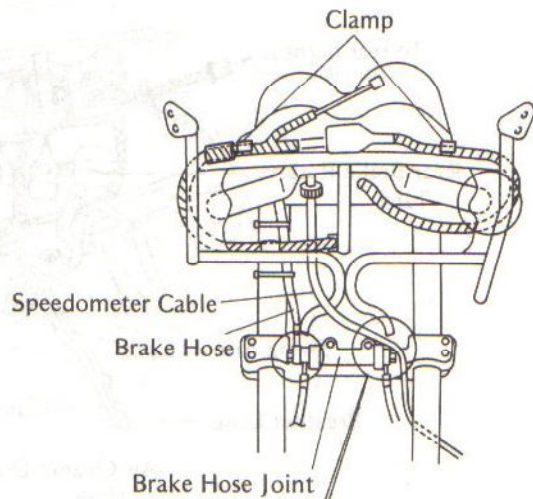
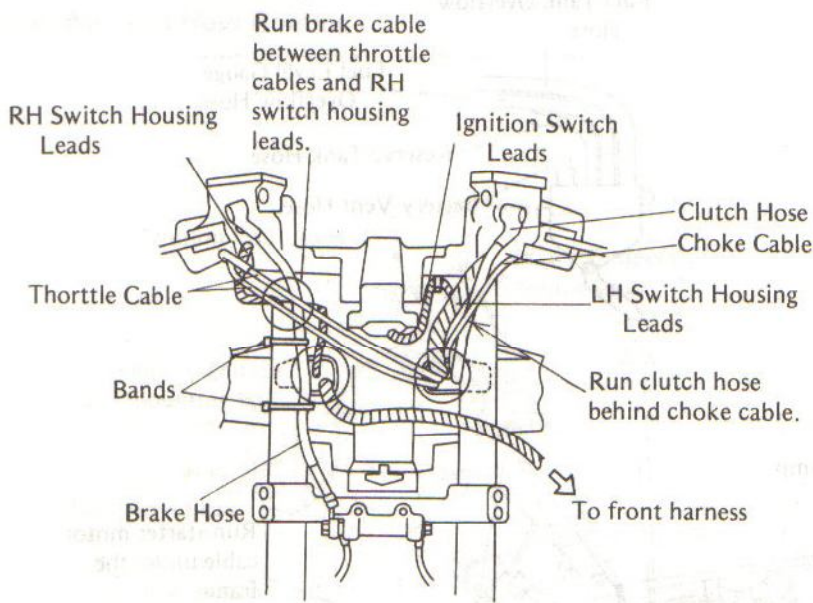

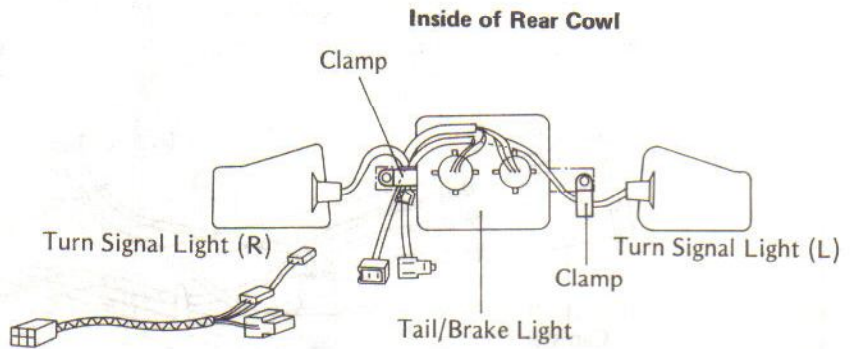
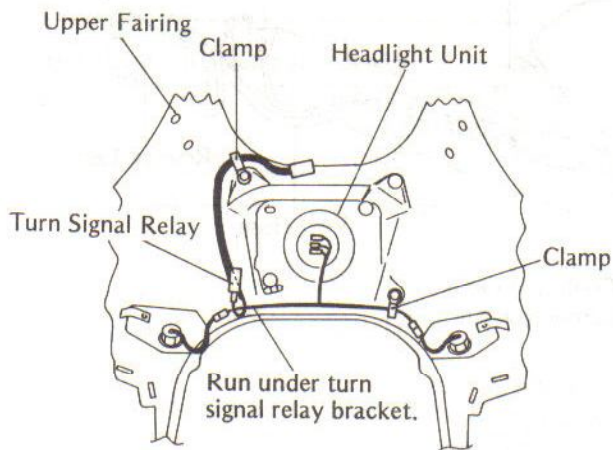
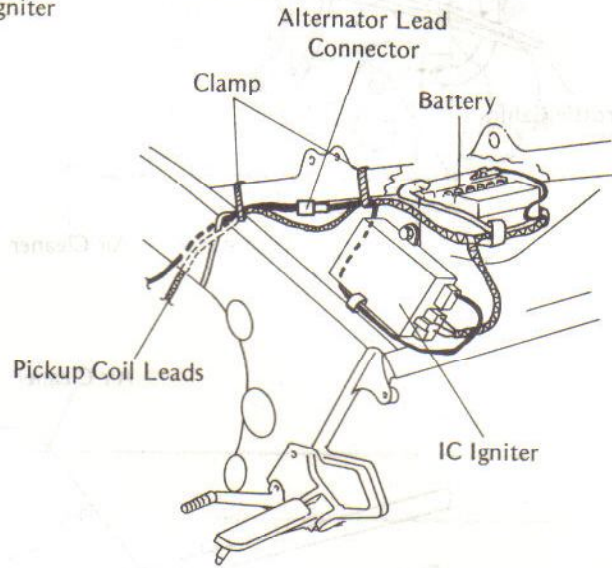
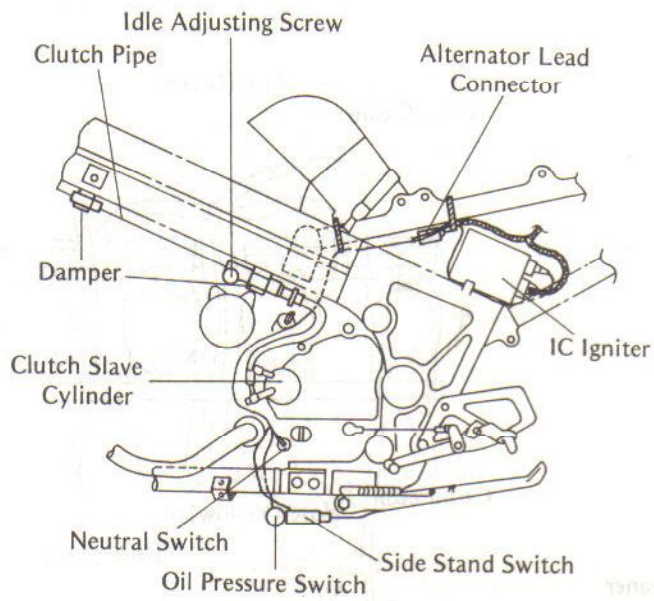

1-18 GENERAL INFORMATION

US and Swiss model

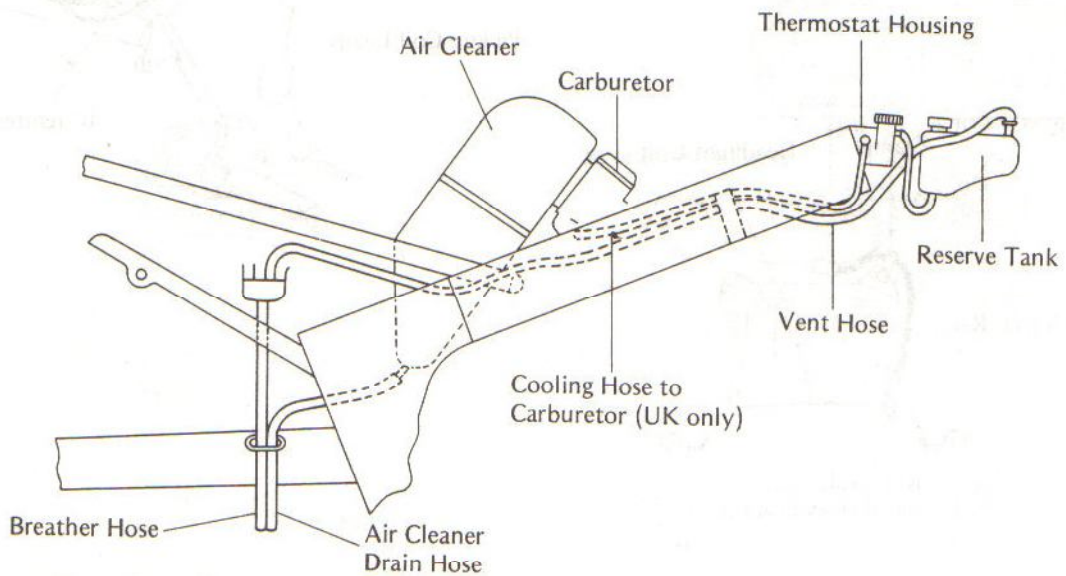
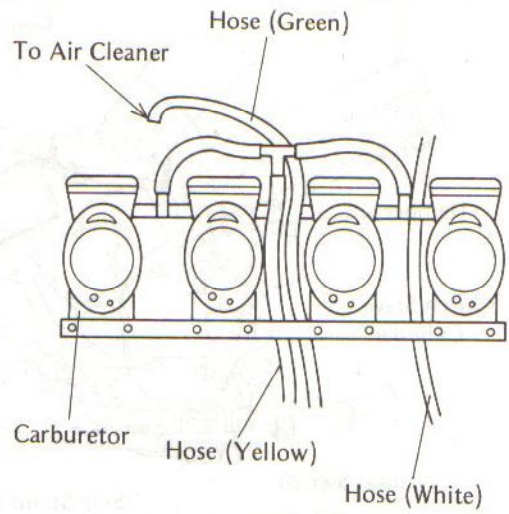
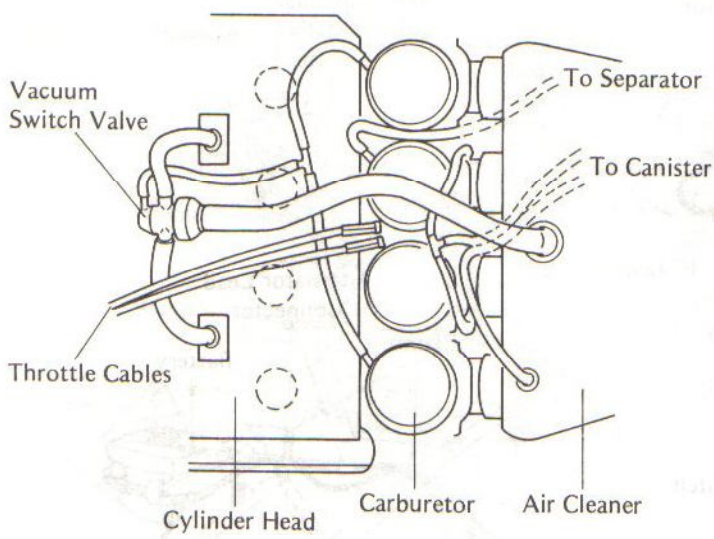

Model

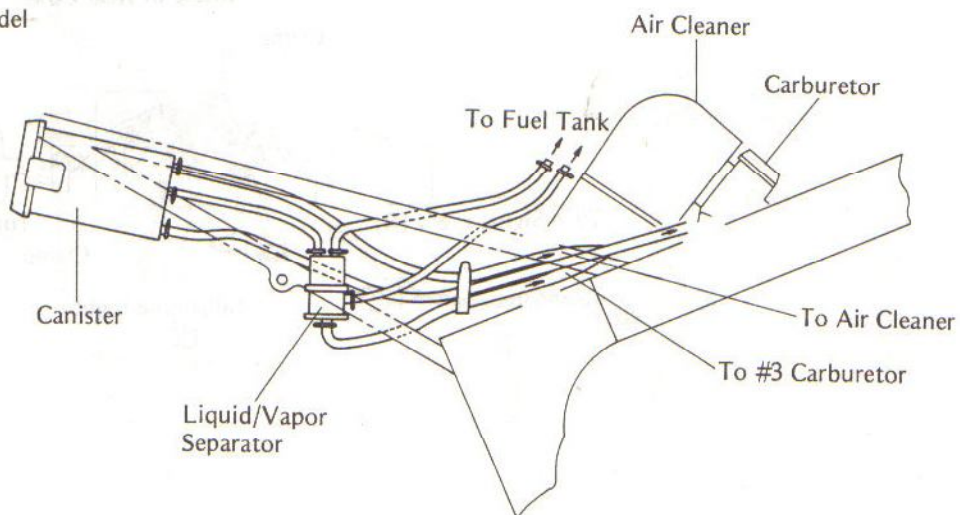

UK model (ZX1000-B1 model)

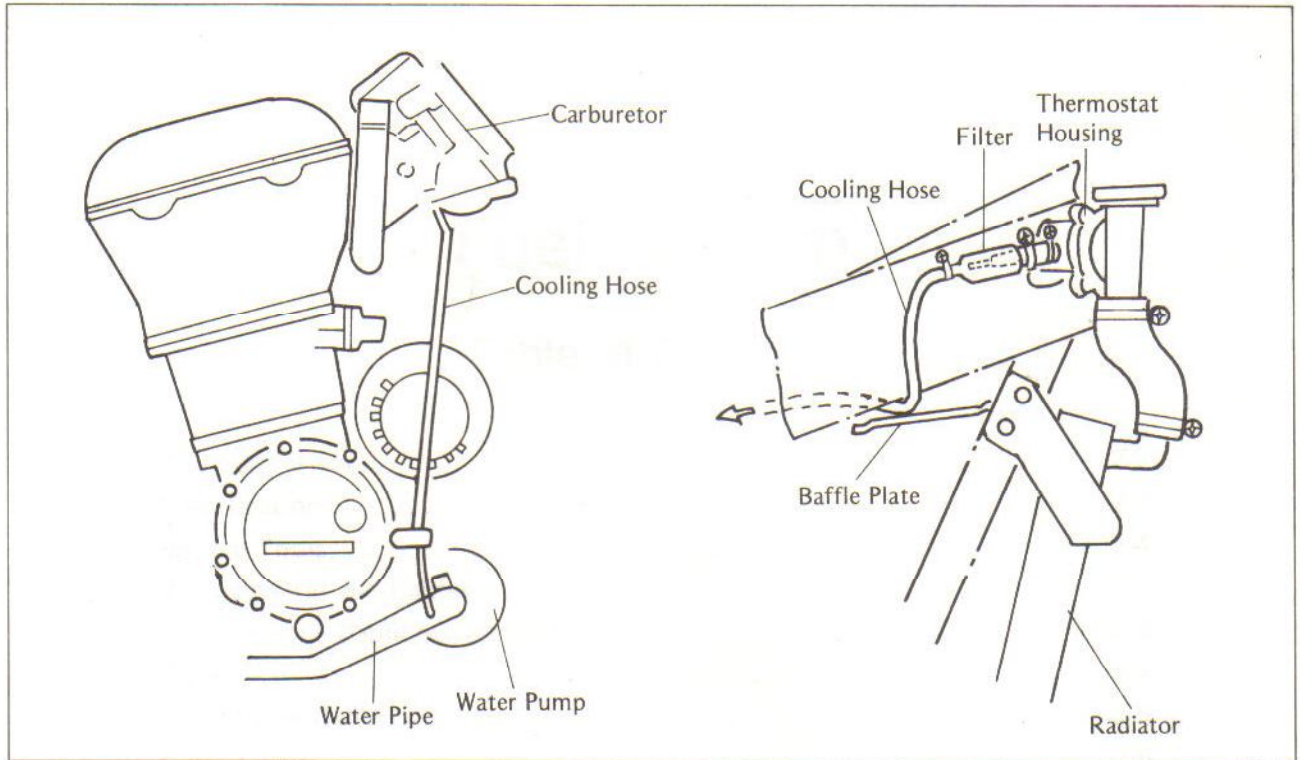

UK model (ZX1000-B2 and later models)

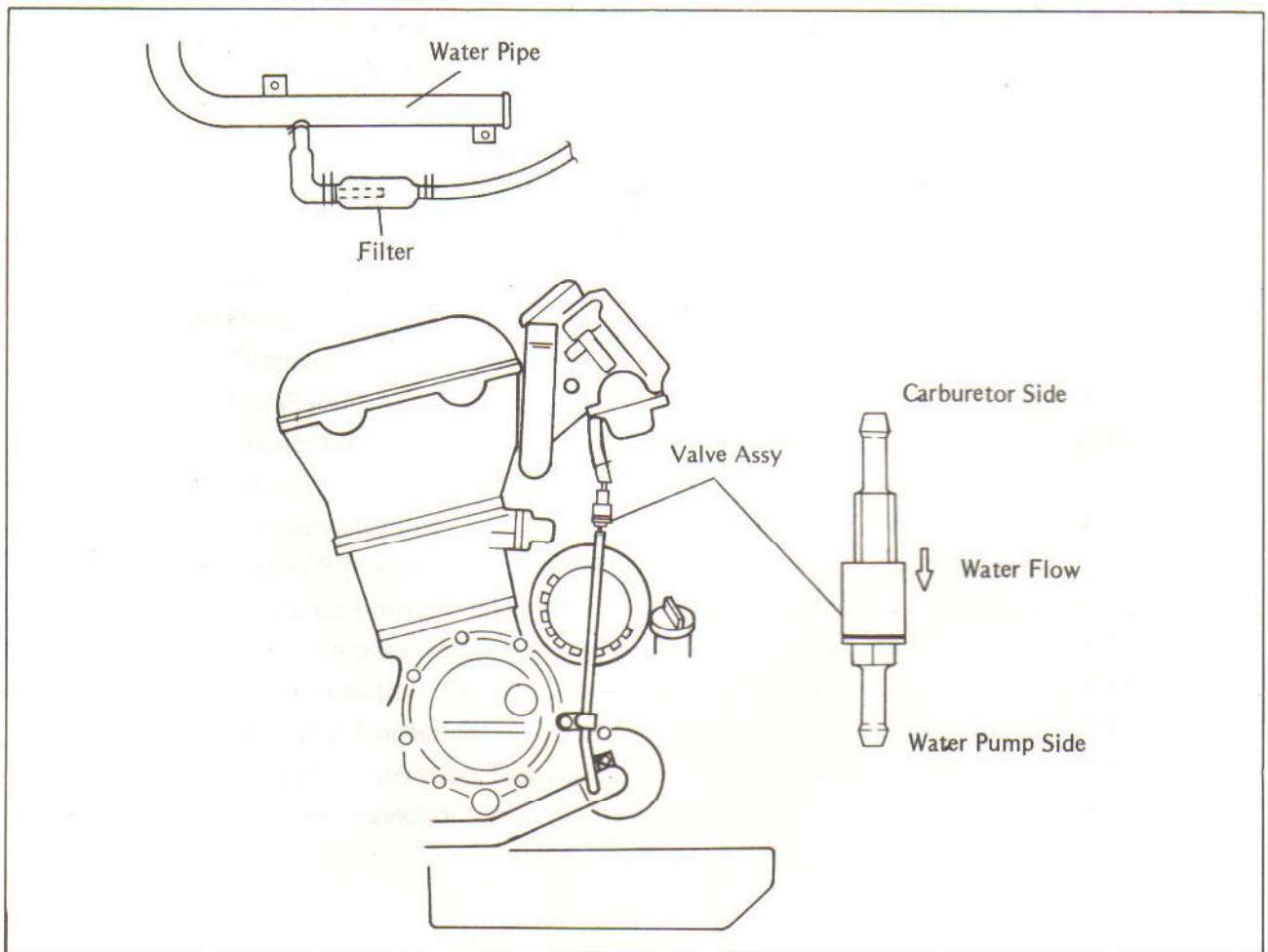

Fuel System

Table of Contents

Exploded View	2-2
Specifications	2-4
Special Tools	2-4
Throttle Grip and Cables	2-5
Throttle Cable Adjustment	2-5
Choke Cable	2-5
Choke Cable Adjustment	2-5
Carburetors	2-6
Idle Speed Adjustment	2-6
High Altitude Performance Adjustment (US model)	2-6
Carburetor Synchronization	2-7
Service Fuel Level Adjustment	2-7
Fuel System Cleanliness Inspection	2-8
Coolant Filter Cleaning (UK Model)	2-9
Carburetor Disassembly/Assembly	2-9
Carburetor Inspection	2-10
Fuel Pump and Filter	2-11
Removal	2-11
Installation	2-11
Inspection	2-11
Air Cleaner	2-11
Element Cleaning	2-11
Evaporative Emission Control system	
(US California Vehicle only)	2-12
Parts Removal/Installation Notes	2-12
Hose Inspection (Periodic Inspection)	2-12
Separator Inspection	2-12
Separator Operation Test	2-12
Canister Inspection	2-13



Download the full PDF manual instantly.

Our customer service e-mail:

aservicemanualpdf@yahoo.com