

HONDA

SERVICE MANUAL



86-88

TRX 200SX

FOURTRAX

IMPORTANT SAFETY NOTICE

 **WARNING** *Indicates a strong possibility of severe personal injury or loss of life if instructions are not followed.*

CAUTION: *Indicates a possibility of personal injury or equipment damage if instructions are not followed.*

NOTE: Gives helpful information.

Detailed descriptions of standard workshop procedures, safety principles and service operations are not included. It is important to note that this manual contains some warnings and cautions against some specific service methods which could cause **PERSONAL INJURY** to service personnel or could damage a vehicle or render it unsafe. Please understand that those warnings could not cover all conceivable ways in which service, whether or not recommended by Honda might be done or of the possibly hazardous consequences of each conceivable way, nor could Honda investigate all such ways. Anyone using service procedures or tools, whether or not recommended by Honda *must satisfy himself thoroughly* that neither personal safety nor vehicle safety will be jeopardized by the service method or tools selected.

HOW TO USE THIS MANUAL

Sections 1 through 3 apply to the whole Four Trax, while sections 4 through 18 describe parts of the Four Trax, grouped according to location.

Find the section you want on this page, then turn to the table of contents on page 1 of that section.

Most sections start with an assembly or system illustration, service information and troubleshooting for the section. The subsequent pages give detailed procedures.

If you don't know what the source of a problem is, refer to section 19, Troubleshooting.

CONTENTS

	GENERAL INFORMATION	1
	LUBRICATION	2
	MAINTENANCE	3
ENGINE	FUEL SYSTEM	4
	ENGINE REMOVAL/INSTALLATION	5
	CYLINDER HEAD/VALVES	6
	CYLINDER/PISTON	7
	CLUTCH/GEARSHIFT LINKAGE	8
	RECOIL STARTER/ALTERNATOR/ STARTER CLUTCH	9
	CRANKCASE/CRANKSHAFT/ TRANSMISSION	10
	CHASSIS	FRONT WHEEL/SUSPENSION/STEERING
BRAKES		12
REAR WHEEL/SUSPENSION		13
FENDERS/EXHAUST MUFFLER		14
ELECTRICAL	IGNITION SYSTEM	15
	BATTERY/CHARGING SYSTEM	16
	STARTER SYSTEM	17
	LIGHTS/SWITCHES	18
	TROUBLESHOOTING	19
	INDEX	20

1. GENERAL INFORMATION

GENERAL SAFETY	1-1	TORQUE VALUES	1-5
SERVICE RULES	1-1	TOOLS	1-7
MODEL IDENTIFICATION	1-2	CABLE & HARNESS ROUTING	1-9
SPECIFICATIONS	1-3		

1

GENERAL SAFETY

WARNING

If the engine must be running to do some work, make sure the area is well-ventilated. Never run the engine in a closed area. The exhaust contains poisonous carbon monoxide gas.

WARNING

The battery generates hydrogen gas which can be highly explosive. Do not smoke or allow flames or sparks near the battery, especially while charging it.

WARNING

Gasoline is extremely flammable and is explosive under certain conditions. Do not smoke or allow flames or sparks in your work area.

WARNING

The battery electrolyte contains sulfuric acid. Protect your eyes, skin and clothing. In case of contact, flush thoroughly with water and call a doctor if electrolyte gets in your eyes.

SERVICE RULES

1. Use genuine HONDA or HONDA-recommended parts and lubricants or their equivalents. Parts that don't meet HONDA's design specifications may cause damage to the Four Trax.
2. Use the special tools designed for this product to avoid damage and incorrect assembly.
3. Use only metric tools when servicing this Four Trax. Metric bolts, nuts and screws are not interchangeable with English fasteners.
4. Install new gaskets, O-rings, cotter pins, and lock plates when reassembling.
5. When tightening bolts or nuts, begin with the larger-diameter or inner bolt first. Then tighten to the specified torque diagonally in 1-5 steps, unless a particular sequence is specified.
6. Clean parts in non-flammable or high flash point solvent upon disassembly.
7. Lubricate any sliding surfaces before reassembly.
8. After reassembly, check all parts for proper installation and operation.

MODEL IDENTIFICATION



(1) FRAME SERIAL NUMBER



The frame serial number is stamped on the frame left side under the rear fender.

(2) ENGINE SERIAL NUMBER

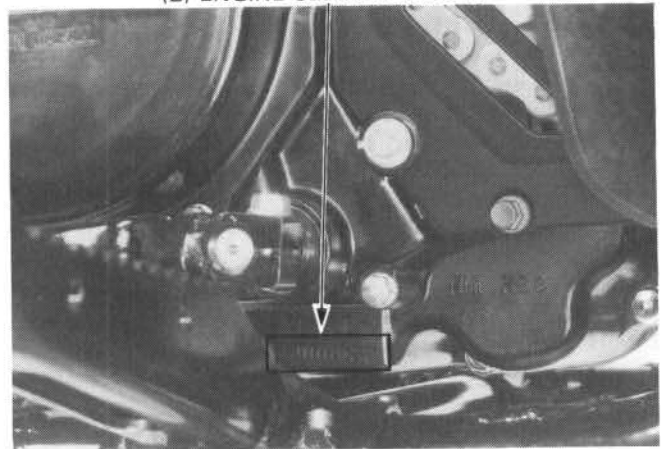

The engine serial number is stamped on the crankcase lower left side.

(3) CARBURETOR IDENTIFICATION NUMBER

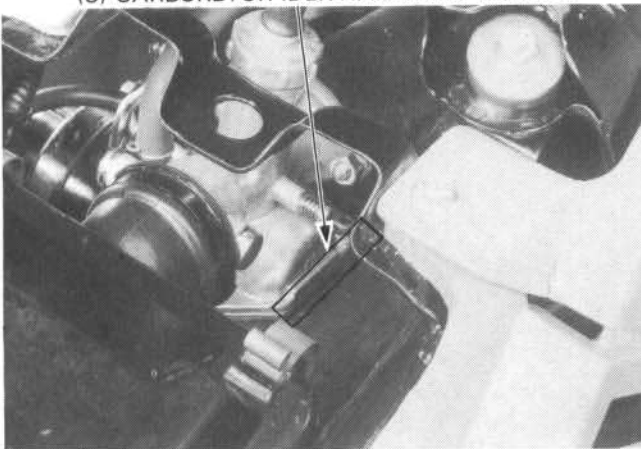

The carburetor identification number is stamped on the carburetor body right side.

SPECIFICATIONS

ITEM		SPECIFICATIONS
DIMENSIONS	Overall length	1,660 mm (65.4 in)
	Overall width	1,000 mm (39.4 in)
	Overall height	1,015 mm (40.0 in)
	Wheel base	1,064 mm (41.9 in)
	Seat height	740 mm (29.1 in)
	Foot peg height	275 mm (10.8 in)
	Ground clearance	120 mm (4.7 in)
	Dry weight	160 kg (353 lb)
FRAME	Type	Semi-double cradle
	Front suspension, travel	Double wish-bone, 80 mm (3.1 in)
	Rear suspension, travel	Swing arm 100 mm (3.9 in)
	Rim size	Front Rear
		5.5 x 8 DC
		8.25 x 8 DC
	Front tire size, pressure	20 x 7.00-8, 2.8 psi (21 kPa, 0.21 kg/cm ²)
	Rear tire size, pressure	22 x 11.00-8, 2.4 psi (17 kPa, 0.17 kg/cm ²)
	Front brake, lining swept area	Hydraulic operated leading trailing shoe, 50.4 cm ² (7.8 sq in) x 2
	Rear brake, lining swept area	Cable operated leading trailing shoe, 77.5 cm ² (12.0 sq in) x 2
	Fuel tank capacity	8.5 liters (2.2 US gal, 1.9 Imp gal)
	Fuel reserve capacity	2.0 liters (0.5 US gal, 0.4 Imp gal)
	Toe-in	10 mm (0.4 in)
	Caster angle	4°30'
	Camber angle	1°
Trail length	18 mm (0.7 in)	
Tread	Front Rear	
	750 mm (29.5 in)	
	750 mm (29.5 in)	
ENGINE	Type	Air cooled 4-stroke
	Cylinder arrangement	Single cylinder inclined 25°
	Bore and stroke	65.0 x 60.0 mm (2.55 x 2.36 in)
	Displacement	199.1 cm ³ (12.15 cu in)
	Compression ratio	9 : 1
	Valve train	Single overhead camshaft, chain driven
	Maximum horsepower	14.5 HP/7,000 rpm (SAE)
	Maximum torque	1.56 kg-m (11.28 ft-lb)/6,000 rpm (SAE)
	Oil capacity	1.9 liters (2.0 US qt, 1.7 Imp qt) after disassembly 1.6 liters (1.7 US qt, 1.4 Imp qt) after draining
	Lubrication system	Forced pressure and wet sump
	Air filtration	Double urethane
	Cylinder compression	1,300 ± 100 kPa (13.0 ± 1.0 kg/cm ² , 184 ± 14 psi)
	Intake valve	Opens Closes
		8° BTDC 35° ABDC
	Exhaust valve	Opens Closes
		40° BBDC 5° ATDC
	Valve clearance (cold)	Intake Exhaust
	0.08 mm (0.003 in) 0.08 mm (0.003 in)	
Idle speed	1,400 ± 100 rpm	
CARBURETOR	Type	Dual valve
	Identification number	63A
	Venturi dia.	22 mm (0.87 in)
	Air screw initial opening	1-1/2 turns out
	Jet needle	4 groove
	Float level	14 ± 1 mm (0.55 ± 0.04 in)

GENERAL INFORMATION

ITEM		SPECIFICATIONS
DRIVE TRAIN	Clutch	Wet multi-plate, semi-automatic
	Transmission	5-speed constant mesh with reverse
DRIVE TRAIN	Primary reduction	3.087 (71/23)
	Gear ratios	3.546 (39/11)
	(Overall: 1)	2.267 (34/15)
	I	1.632 (31/19)
	II	1.273 (28/22)
	III	1.042 (25/24)
	IV	5.850 (33/11 x 39/20)
	V	3.500 (42/12)
	Reverse	Left foot operated return system, Forward: N-I-II-III-IV-V Reverse: N-R
	Final reduction	
Gearshift pattern		
ELECTRICAL	Ignition	CDI
	Ignition timing	10° BTDC at idle
		28° BTDC at 3,700 rpm
	Alternator capacity	130 W/5,000 rpm
	Battery	12V - 10AH
	Spark plug	DR8ES-L (NGK) X24ESR-U (ND)
	Spark plug gap	0.6-0.7 mm (0.024-0.028 in)
	Fuse	15A
	Headlight	12V 45W/45W
	Taillight	12V 5W
	Neutral indicator	12V 3W
	Reverse indicator	12V 3W
		Initial
	Full advance	

TORQUE VALUES

ENGINE

Item	Q'ty	Thread dia. (mm)	Torque N·m (kg-m, ft-lb)	Remarks
Cylinder head bolt	4	8	28-30 (2.8-3.0, 20-22)	Apply oil to the threads.
Spark plug	1	12	12-19 (1.2-1.9, 9-14)	
Camshaft bearing holder	2	6	10-14 (1.0-1.4, 7-10)	
Valve adjuster lock bolt	2	6	10-14 (1.0-1.4, 7-10)	Apply oil to the threads.
Cam chain tensioner slipper	1	6	10-14 (1.0-1.4, 7-10)	
Oil drain bolt	1	12	35-40 (3.5-4.0, 25-29)	Apply oil to the threads.
Clutch adjusting screw lock nut	1	8	19-25 (1.9-2.5, 14-18)	
Pulse generator	2	5	8-12 (0.8-1.2, 6-9)	Apply oil to the threads.
Centrifugal clutch lock nut	1	18	86-94 (8.6-9.4, 62-68)	
Manual clutch lock nut	1	16	76-84 (7.6-8.4, 55-61)	
Flywheel bolt	1	8	30-34 (3.0-3.4, 22-25)	
Starter clutch	3	8	26-30 (2.6-3.0, 19-22)	Apply thread lock agent to the threads.
Shift drum bolt	1	6	10-14 (1.0-1.4, 7-10)	
Shift drum stopper	1	6	10-14 (1.0-1.4, 7-10)	Apply oil to the threads.

FRAME

Item	Q'ty	Thread dia. (mm)	Torque N·m (kg-m, ft-lb)	Remarks
Engine mount bolt	5	10	60-80 (6.0-8.0, 43-58)	
Engine hanger plate	2	8	30-40 (3.0-4.0, 22-29)	
Gearshift pedal	1	6	10-12 (1.0-1.2, 7-9)	
Foot peg	8	8	24-30 (2.4-3.0, 17-22)	
Front wheel nut	8	10	60-70 (6.0-7.0, 43-51)	
Tie-rod ball joint	4	10	35-43 (3.5-4.3, 25-31)	
Tie-rod lock nut	4	10	35-43 (3.5-4.3, 25-31)	
Kingpin bolt	2	12	50-70 (5.0-7.0, 36-51)	
Front axle nut	2	14	60-80 (6.0-8.0, 43-58)	
Front shock absorber	4	10	40-50 (4.0-5.0, 29-36)	
Front arm 8 mm	8	8	30-36 (3.0-3.6, 22-26)	
10 mm	4	10	40-50 (4.0-5.0, 29-36)	
Steering bearing outer race lock nut	1	42	40-60 (4.0-6.0, 29-43)	
Handlebar lower holder	4	10	40-50 (4.0-5.0, 29-36)	
Steering shaft nut	1	12	50-70 (5.0-7.0, 36-51)	
Brake hose oil bolt	5	10	25-35 (2.5-3.5, 18-25)	
Rear axle inner lock nut	1	32	35-45 (3.5-4.5, 25-33)	
Rear axle outer lock nut	1	32	120-140 (12.0-14.0, 87-101)	
Rear axle nut	2	18	80-120 (8.0-12.0, 58-87)	
Rear wheel n128		10	60-70 (6.0-7.0, 43-51)	
Rear shock absorber	2	10	40-50 (4.0-5.0, 29-36)	
Final driven sprocket nut	4	8	30-36 (3.0-3.6, 22-26)	
Swing arm pivot bolt	1	14	80-100 (8.0-10.0, 58-72)	
Axle housing lock bolt	4	12	80-100 (8.0-10.0, 58-72)	
Mudguard	6	6	10-14 (1.0-1.4, 7-10)	
Inner fender	6	6	10-14 (1.0-1.4, 7-10)	
Air scoop grille	2	6	10-14 (1.0-1.4, 7-10)	
Fuel valve	1	18	25-30 (2.5-3.0, 18-22)	
Headlight bracket	2	8	20-25 (2.0-2.5, 14-18)	
Fuel valve knob	1	5	4.5-6 (0.45-0.6, 3.3-4.3)	

GENERAL INFORMATION

Torque specifications listed on previous page are for important fasteners. Others should be tightened to standard torque values listed below.

STANDARD TORQUE VALUES

Item	Torque Values N·m (kg-m, ft-lb)	Item	Torque Values N·m (kg-m, ft-lb)
5 mm bolt and nut	4-6 (0.4-0.6, 3-4)	5 mm screw	3-5 (0.3-0.5, 2-4)
6 mm bolt and nut	8-12 (0.8-1.2, 6-9)	6 mm screw	7-11 (0.7-1.1, 5-8)
8 mm bolt and nut	18-25 (1.8-2.5, 13-18)	6 mm flange bolt and nut	10-14 (1.0-1.4, 7-10)
10 mm bolt and nut	30-40 (3.0-4.0, 22-29)	8 mm flange bolt and nut	24-30 (2.4-3.0, 17-22)
12 mm bolt and nut	50-60 (5.0-6.0, 36-43)	10 mm flange bolt and nut	35-45 (3.5-4.5, 25-33)

TOOLS

SPECIAL

DESCRIPTION	TOOL NUMBER	ALTERNATIVE TOOL	TOOL NUMBER	REF. SECT.
*Clutch holder	07GMB-HB30100			8
*Clutch puller	07GMC-HB30100			8
*Tire breaker attachment	07GMF-HB30100			11
Valve guide reamer, 5.5 mm	07984-2000000	Valve guide reamer, 5.5 mm	07984-0890000	6
Clutch center holder	07923-9580000			8
Bearing remover set, 15 mm	07936-KC10000	Not available in U.S.A.		10
-Bearing remover, 15 mm	07936-KC10500			10
-Bearing remover weight	07741-0010201	Bearing remover weight	07936-3710200	10
Universal bearing puller	07631-0010000	Equivalent commercially		10
Crankshaft assembly collar	07965-VM00100	available in U.S.A.		10
Shaft puller	07965-VM00200			10
Threaded adapter	07GMF-HB50100			10
Shock absorber compressor adapter	07967-VM50100			11
Shock absorber collar	07967-GA70102	Shock absorber collar	07967-GA70001	11
Lock nut wrench adapter	07GMA-HA70200			11
Snap ring pliers	07914-3230001			12
Lock nut spanner, 41 mm	07916-9580200	Axle nut holder wrench	07916-958020A	12
Lock nut wrench set, 41 mm	07916-9580300	Not available in U.S.A.		12
-Lock nut wrench, 41 mm	07916-9580400	Axle nut torque wrench	07916-958010A	12
-Lock nut wrench handle	07916-9580500	Not available in U.S.A.		12
Shock absorber compressor adapter	07967-KC10000	Not available in U.S.A.		13
Shock absorber compressor base	07959-MB10000			13
Bearing remover set, 20 mm	07936-3710001	Not available in U.S.A.		13
-Bearing remover, 20 mm	07936-3710600			13
-Bearing remover handle	07936-3710100			13
-Bearing remover weight	07741-0010201	Bearing remover weight	07936-3710200	13

*Newly designed for this model

COMMON

DESCRIPTION	TOOL NUMBER	ALTERNATIVE TOOL	TOOL NUMBER	REF. SECT.
Float level gauge	07401-0010000			4
Valve guide remover, 5.5 mm	07742-0010100	Valve guide remover	07942-3290100	6
Valve spring compressor	07757-0010000	Valve spring compressor	07957-3290001	6
Flywheel holder	07725-0040000	Strap wrench, commercially available in U.S.A.		9
Rotor puller	07733-0010000	Rotor puller	07933-2000000	9
Driver	07749-0010000			10, 11, 12, 13
Attachment, 42 x 47 mm	07746-0010300			10
Pilot, 20 mm	07746-0040500			10, 12, 13
Attachment, 32 x 35 mm	07746-0010100			10, 12, 13
Pilot, 15 mm	07746-0040300			10, 12
Attachment, 52 x 55 mm	07746-0010400			10
Pilot, 22 mm	07746-0041000			10
Attachment, 62 x 68 mm	07746-0010500			10, 13
Pilot, 28 mm	07746-0041100			10
Attachment, 37 x 40 mm	07746-0010200			11, 12
Pilot, 17 mm	07746-0040400			11
Tire breaker set	07772-0050001			11
-Breaker arm compressor	07772-0050101			11
-Breaker arm	07772-0050200			11

GENERAL INFORMATION

DESCRIPTION	TOOL NUMBER	ALTERNATIVE TOOL	TOOL NUMBER	REF. SECT.
Shock absorber compressor Pilot, 35 mm	07959-3290001 07746-0040800			11, 13 13

VALVE SEAT CUTTER

Valve seat cutters are commercially available in the U.S.A. Therefore these cutters are not required in U.S.A.:

DESCRIPTION	TOOL NUMBER	REF. SECT.
Valve seat cutter, 27.5 mm (EX 45°)	07780-0010200	6
Valve seat cutter, 33 mm (IN 45°)	07780-0010800	6
Valve seat cutter, 28 mm (EX 32°)	07780-0012100	6
Valve seat cutter, 33 mm (IN 32°)	07780-0012900	6
Valve seat cutter, 30 mm (IN/EX 60°)	07780-0014000	6
Valve seat cutter holder, 5.5 mm	07781-0010101	6

CABLE & HARNESS ROUTING

Note the following when routing cables and wire harnesses:

- A loose wire, harness or cable can be a safety hazard. After clamping, check each wire to be sure it is secure.
- Do not squeeze a wire against a weld or end of its clamp when a weld-on clamp is used.
- Secure wires and wire harnesses to the frame with their respective wire bands at the designated locations. Tighten the bands so that only the insulated surfaces contact the wires or wire harnesses.
- Route harnesses so they are not pulled taut or have excessive slack.
- Protect wires and harnesses with electrical tape or tubes if they contact a sharp edge or corner. Clean the attaching surface thoroughly before applying tape.
- Do not use a wire or harness with a broken insulator. Repair by wrapping them with protective tape or replace them.
- Route wire harnesses to avoid sharp edges or corners. Also avoid the projected ends of bolts and screws.
- Keep wire harnesses away from the exhaust pipe and other parts that get hot.
- Be sure grommets are seated in their grooves properly.
- After clamping, check each harness to be certain that it is not interfering with any moving or sliding parts.
- Wire harnesses routed along the handlebars should not be pulled taut, have excessive slack, be pinched by, or interfere with adjacent or surrounding parts in all steering positions.
- After routing, check that the wire harnesses are not twisted or kinked.

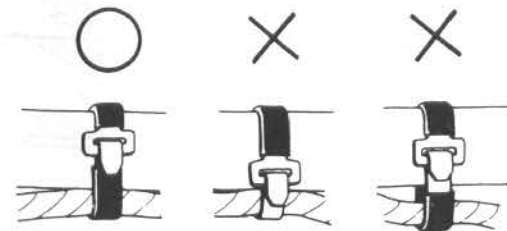
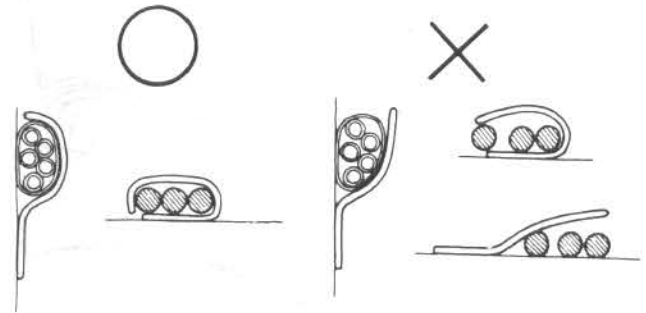

O: CORRECT
X: INCORRECT

GENERAL INFORMATION

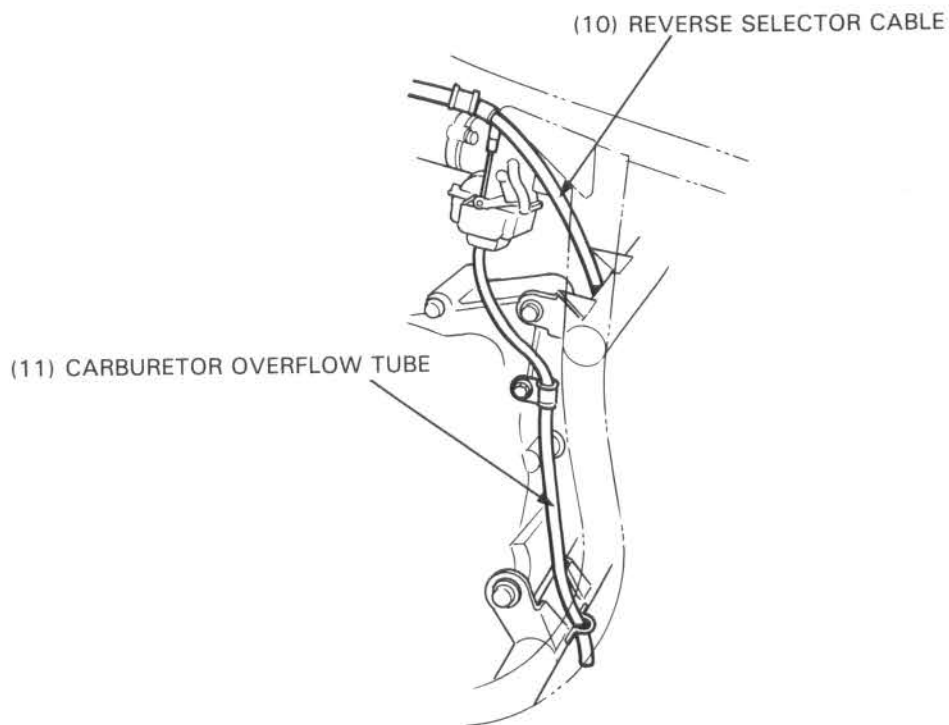
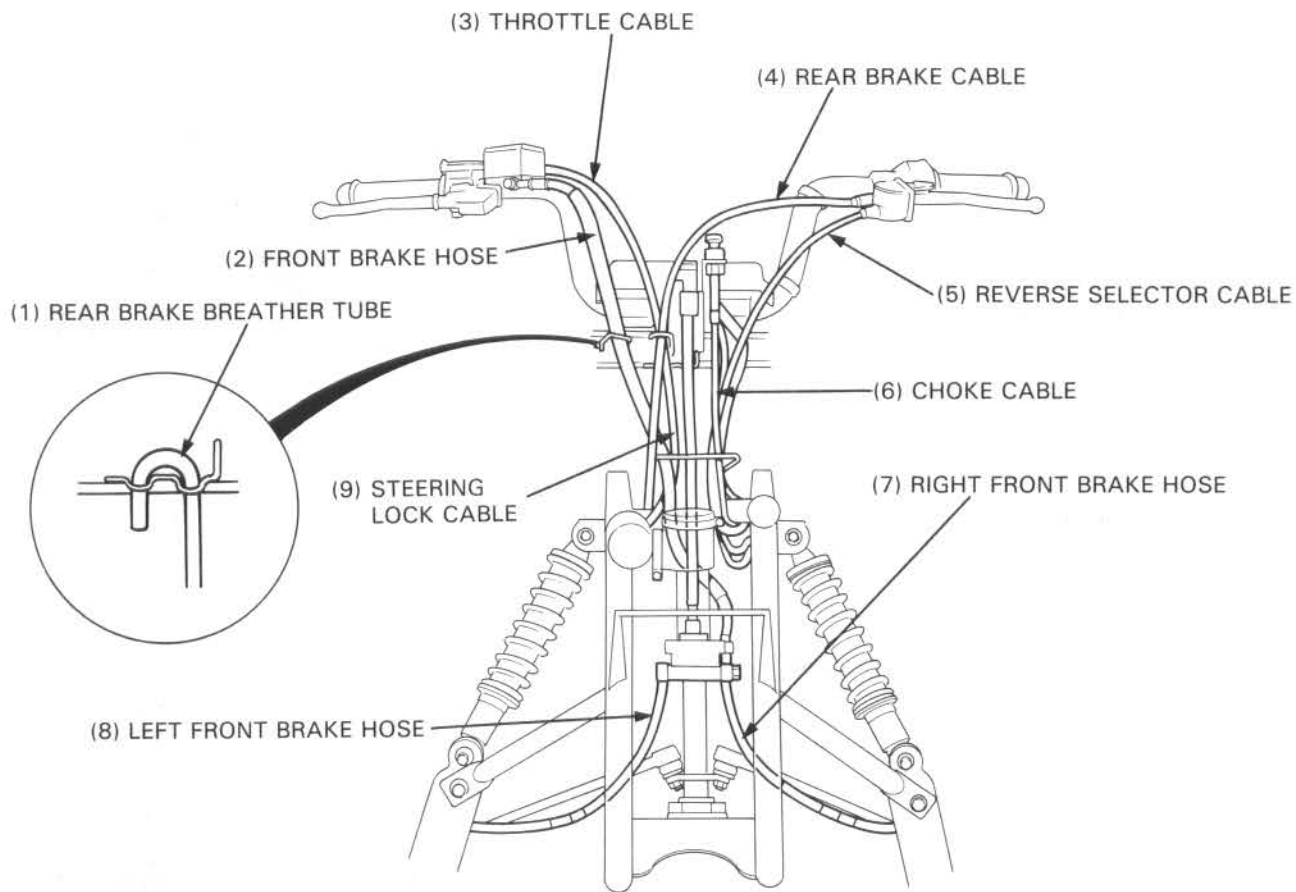

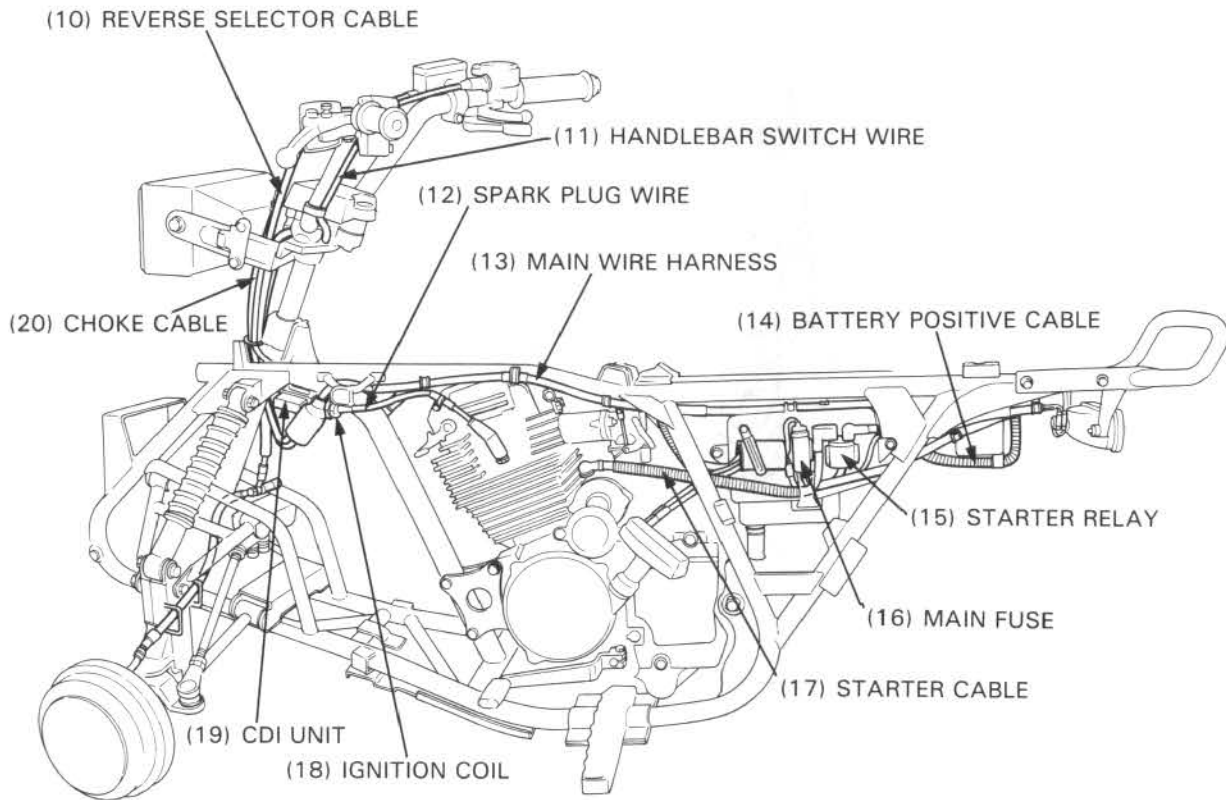
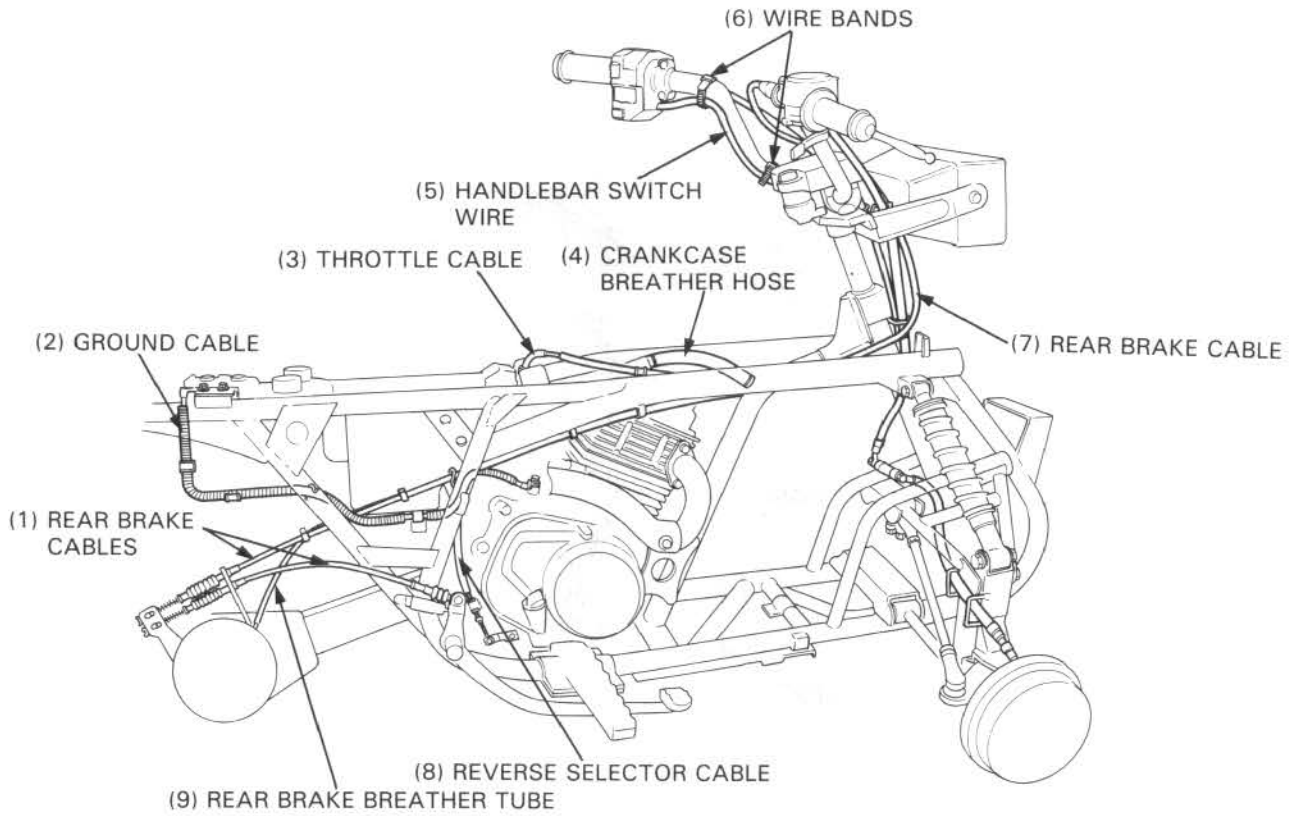

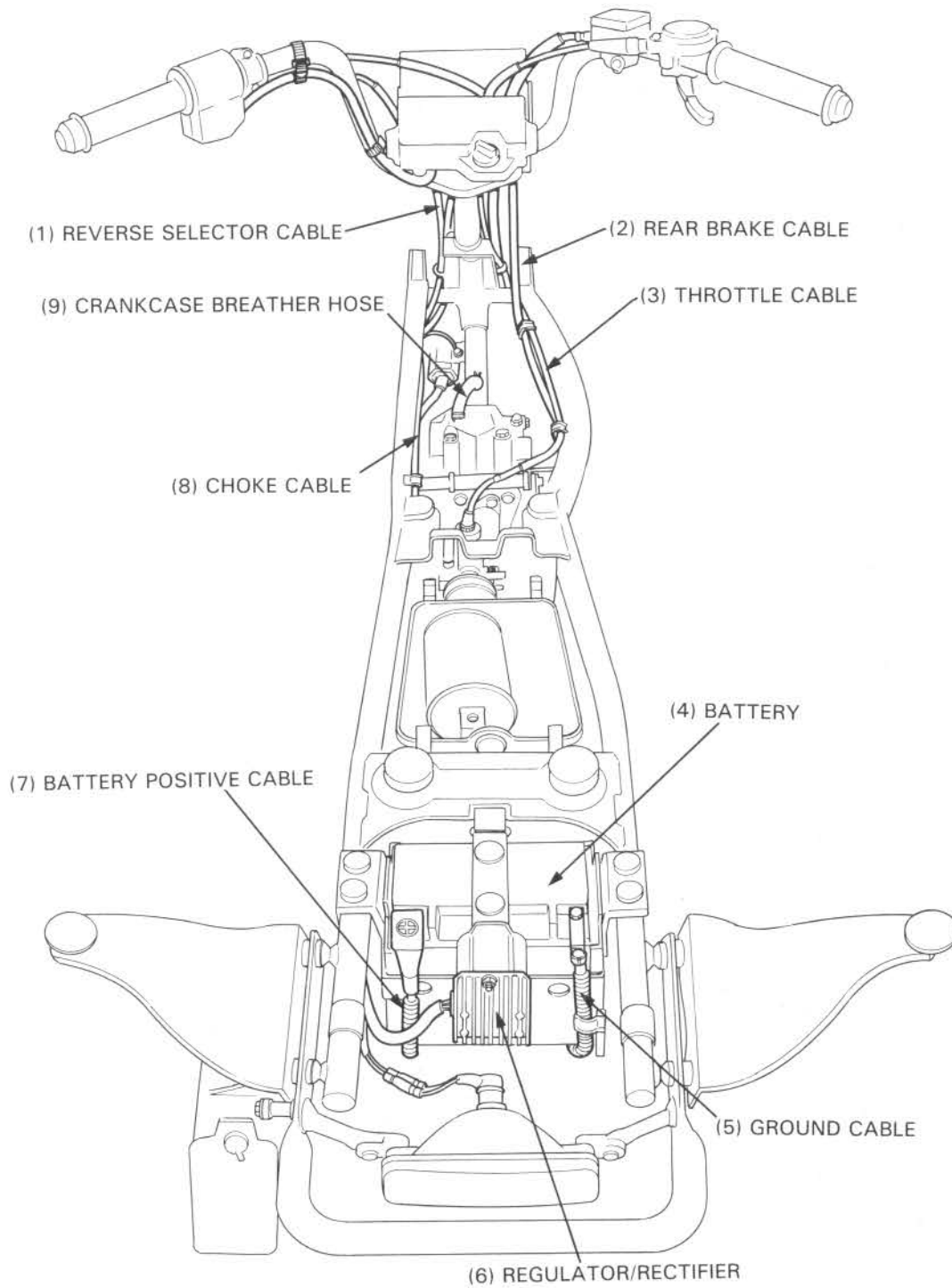

MEMO

RIDE RED

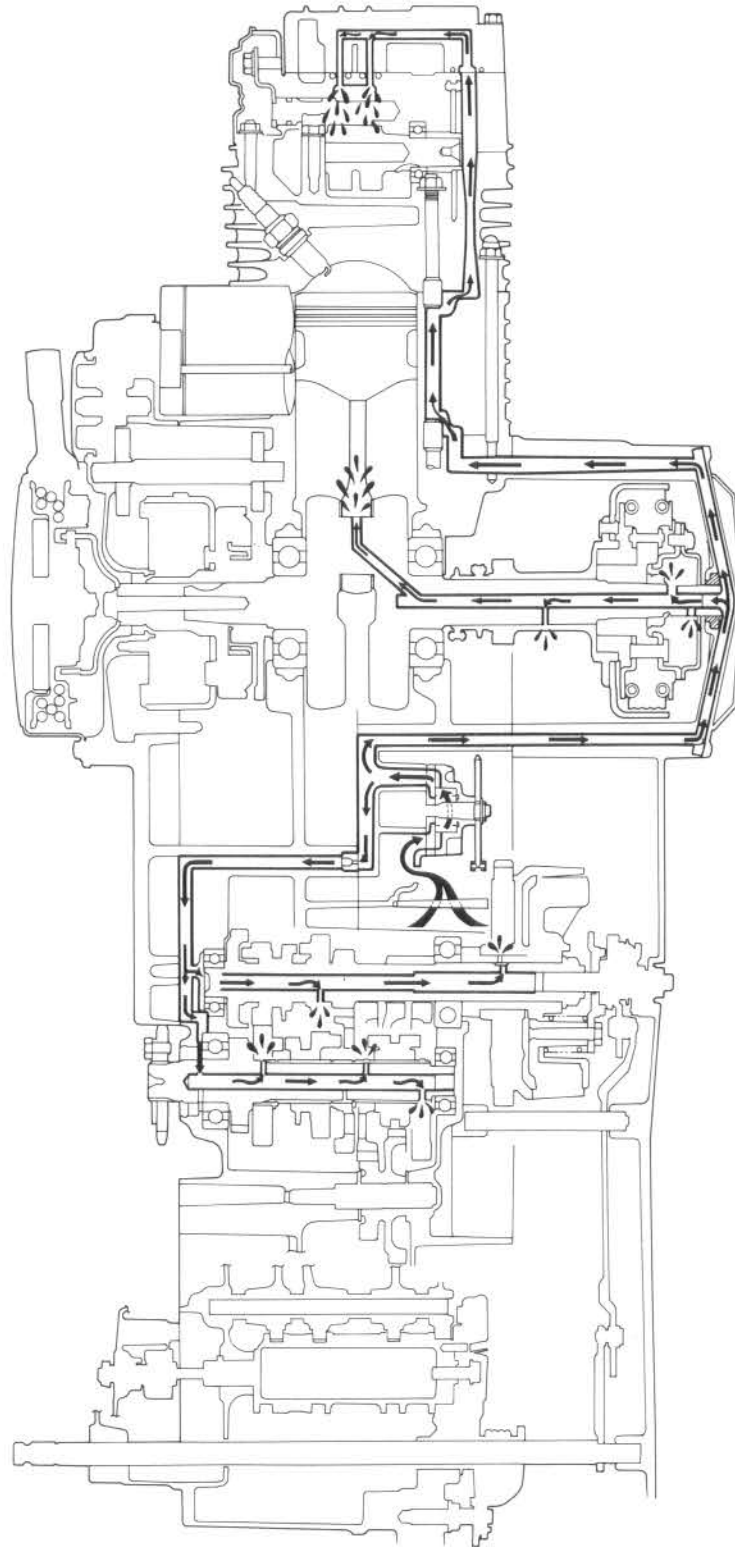

2. LUBRICATION

SERVICE INFORMATION	2-1	OIL FILTER ROTOR AND SCREEN	2-2
TROUBLESHOOTING	2-1	OIL PUMP	2-4
ENGINE OIL	2-2	LUBRICATION POINTS	2-7

SERVICE INFORMATION

SPECIFICATIONS

Engine oil capacity 1.9 lit (2.0 US qt, 1.7 Imp qt) at disassembly
 1.6 lit (1.7 US qt, 1.4 Imp qt) at draining

Engine oil recommendation Use Honda 4-stroke oil or equivalent.
 API Service Classification: SE or SF
 Viscosity: SAE 10W-40

Other viscosities shown in the chart may be used when the average temperature in your riding area is within the indicated range.

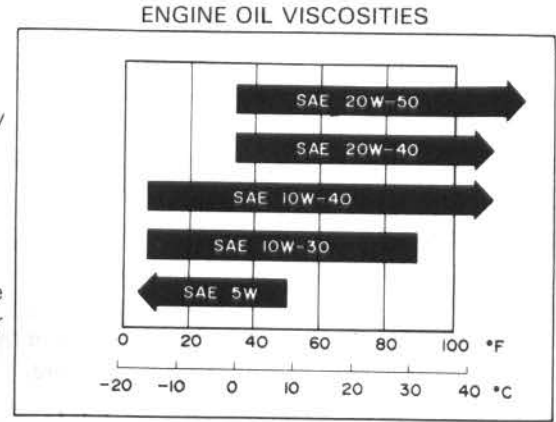

Oil pump

ITEM	STANDARD	SERVICE LIMIT
Rotor tip clearance	0.15 mm (0.006 in)	0.20 mm (0.008 in)
Rotor-to-body clearance	0.15-0.21 mm (0.006-0.008 in)	0.25 mm (0.010 in)
Pump end clearance	0.05-0.13 mm (0.002-0.005 in)	0.15 mm (0.006 in)

TORQUE VALUE

Engine oil drain bolt 35-40 N·m (3.5-4.0 kg-m, 25-29 ft-lb)

TROUBLESHOOTING

Oil level too low - high oil consumption

- External oil leaks
- Worn piston rings
- Oil not changed often enough
- Faulty head gasket

Oil contamination

- Oil not changed or filter not cleaned often enough.
- Head gasket faulty.
- Worn piston rings.

Low oil pressure

- Oil level low
- Clogged oil filter screen
- Faulty oil pump
- External oil leaks
- Broken oil pump drive chain

LUBRICATION

ENGINE OIL

OIL LEVEL

Place the Four Trax on level ground.
Check the oil level with the oil filler cap/dipstick, but do not screw it in when making this check.
If the oil level is below or near the lower level line on the dipstick, add the recommended oil (page 2-1) up to the upper level line.

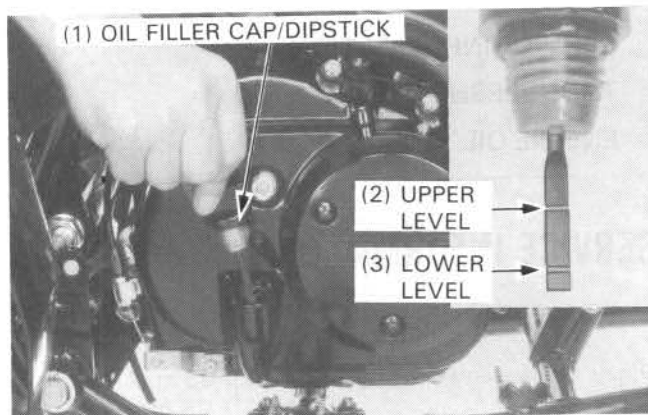

OIL CHANGE

NOTE

- Change engine oil with the engine warm and the Four Trax on level ground to assure complete draining.

Remove the oil filler cap/dipstick and drain bolt, and drain the engine oil.

With the engine switch off, pull the recoil starter several times to completely drain any residual oil.

Check that the sealing washer on the drain bolt is in good condition and install the drain bolt.

TORQUE: 35–40 N·m (3.5–4.0 kg-m, 25–29 ft-lb)

Fill the crankcase with 1.6 liters (1.7 US qt, 1.4 Imp qt) of the recommended oil (page 2-1).
Install the oil filler cap/dipstick.
Start the engine and let it idle for 2 or 3 minutes.

Stop the engine and check that the oil level is at the upper level line on the dipstick. Make sure there are no oil leaks.



OIL FILTER ROTOR AND SCREEN

NOTE

- Clean the oil filter rotor and screen before adding oil.

Drain the engine oil.
Remove the lock nut and reverse selector arm.
Remove the reverse selector cable adjuster lock nut from the cable casing threads, and remove the cable from the cable holder.

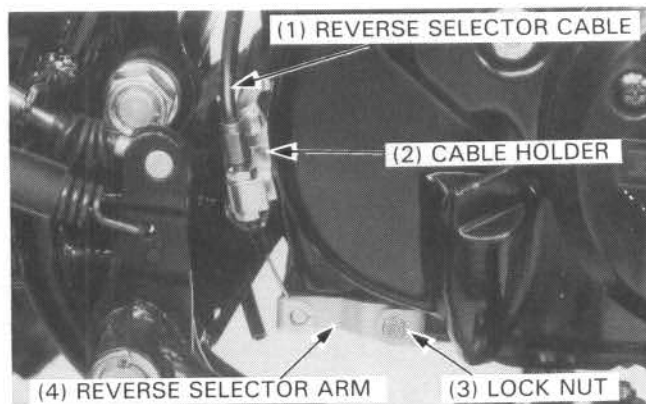

Remove the right crankcase cover bolts and the cover. Remove the gasket and dowel pins.

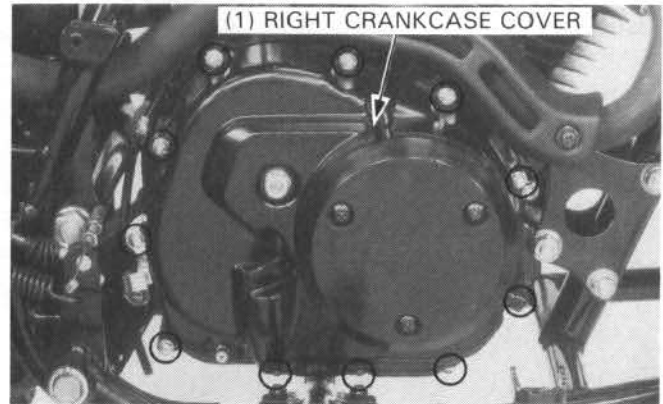

Remove the oil filter rotor cover.

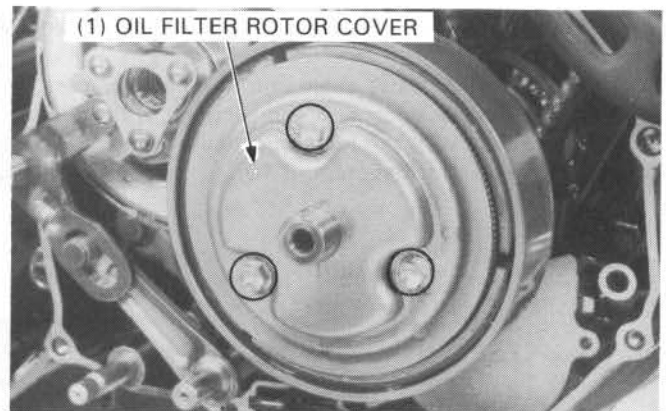

Clean the oil filter rotor cover and the inside of the oil filter rotor using a clean lint-free cloth.

CAUTION

- Do not allow dust or dirt to enter the crankshaft oil passage.
- Do not use compressed air to clean the filter rotor.

Reinstall the oil filter rotor cover with a new gasket, aligning the bolt holes in the cover and gasket.

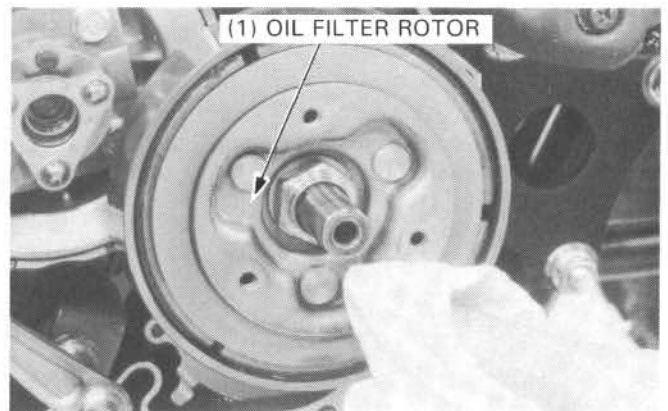

Remove the oil filter screen from the right crankcase. Clean the oil filter screen by washing it in clean solvent and blowing it dry with compressed air. Reinstall the oil filter screen into the right crankcase.



LUBRICATION

Install the dowel pins and a new gasket.

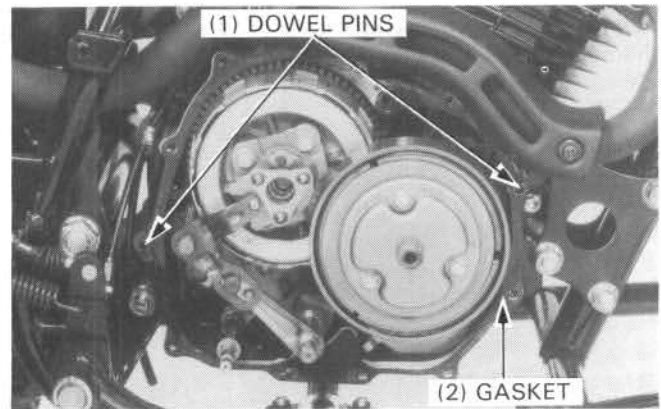

Install the right crankcase cover and tighten the bolt securely.

Install the reverse selector cable onto the cable holder.
Install the reverse selector arm and secure it with the nut.
Fill the crankcase with the recommended oil (page 2-1).
Adjust the reverse lock system (3-10).

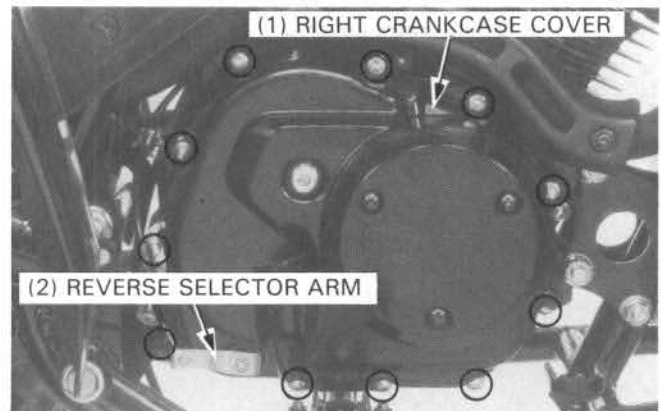

OIL PUMP

REMOVAL

Remove the right crankcase cover (page 2-2).
Remove the oil separator plate.

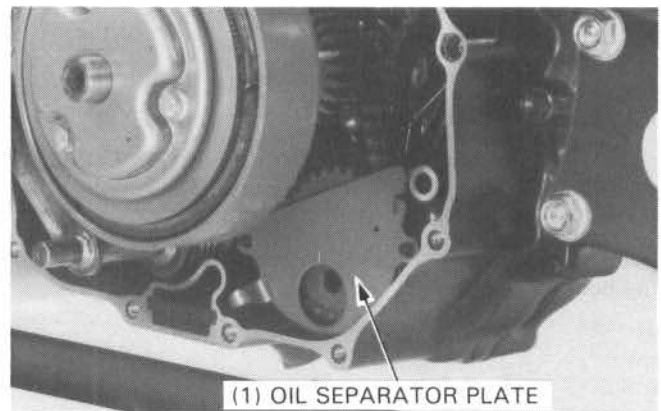

Remove the snap ring and oil pump driven sprocket from the oil pump shaft.

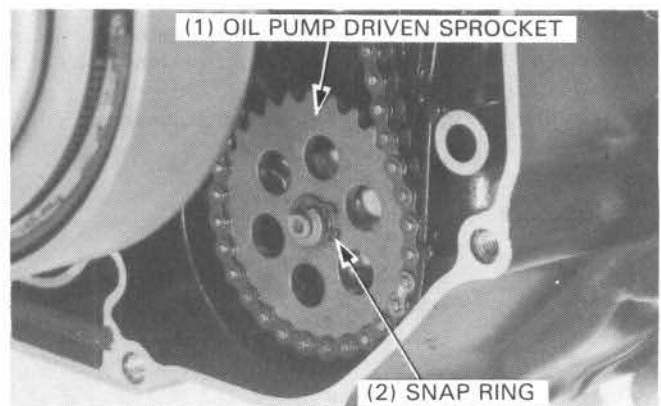

Remove the two flange bolts and the oil pump from the right crankcase.

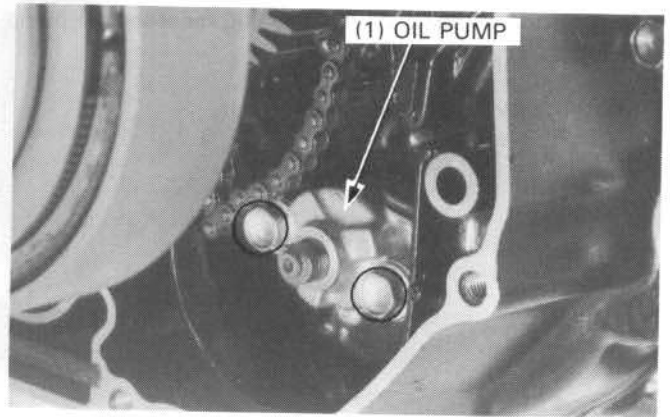

INSPECTION

Remove the oil pump cover attaching screw and the cover.

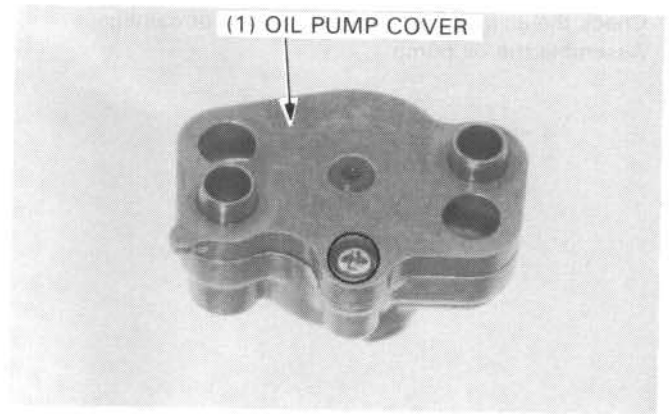

Measure the oil pump body-to-rotor clearance.

SERVICE LIMIT: 0.25 mm (0.010 in)

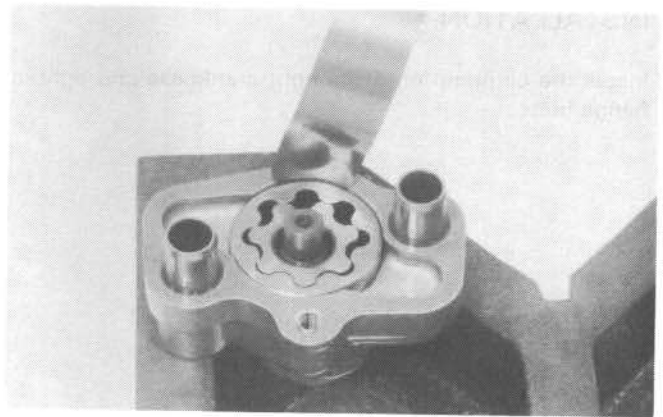

Measure the pump rotor tip clearance.

SERVICE LIMIT: 0.20 mm (0.008 in)

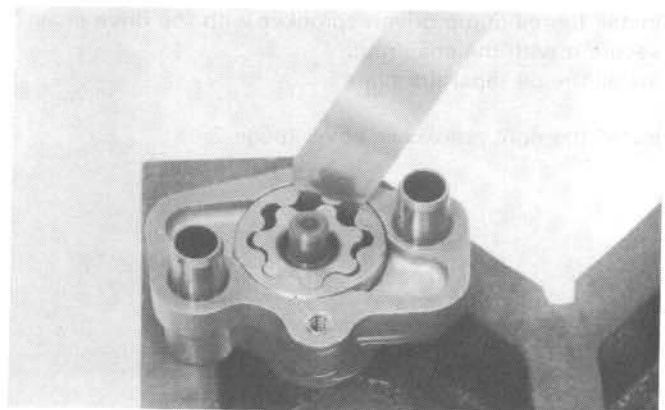

LUBRICATION

Remove the oil pump drive shaft and measure the pump end clearance.

SERVICE LIMIT: 0.15 mm (0.006 in)

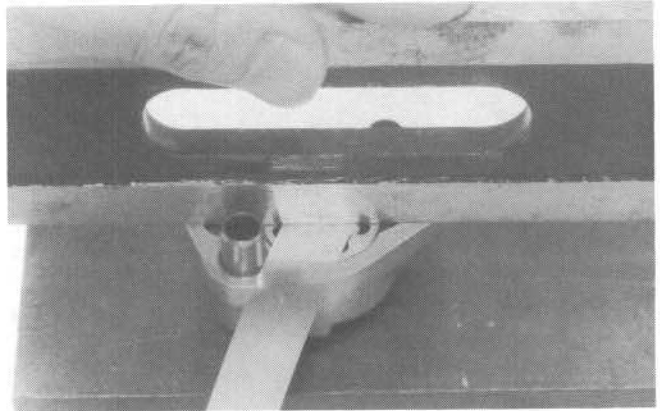

Check the all parts for scratches, wear or damage.
Assemble the oil pump.

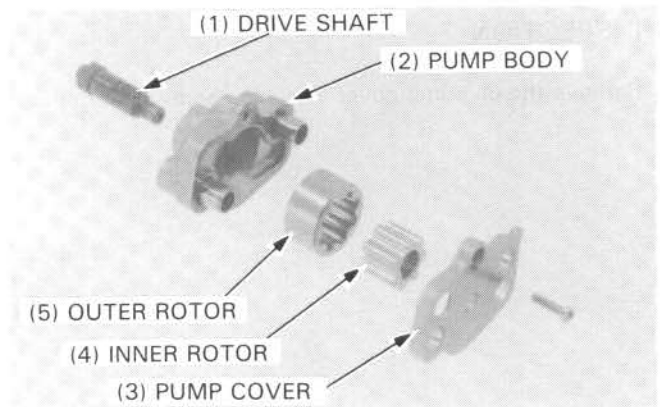

INSTALLATION

Install the oil pump onto the right crankcase and tighten the flange bolts.

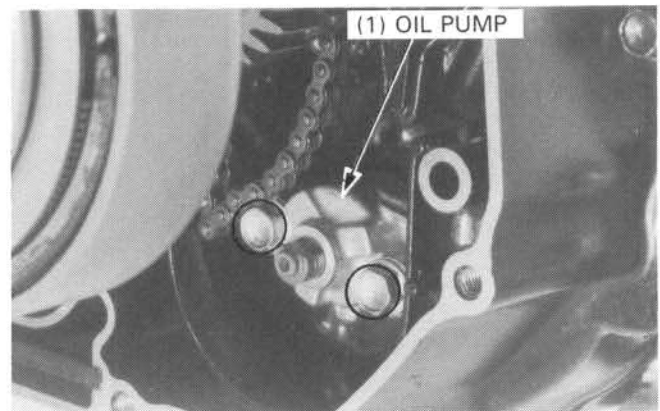

Install the oil pump driven sprocket with the drive chain and secure it with the snap ring.
Install the oil separator plate.

Install the right crankcase cover (page 2-4).

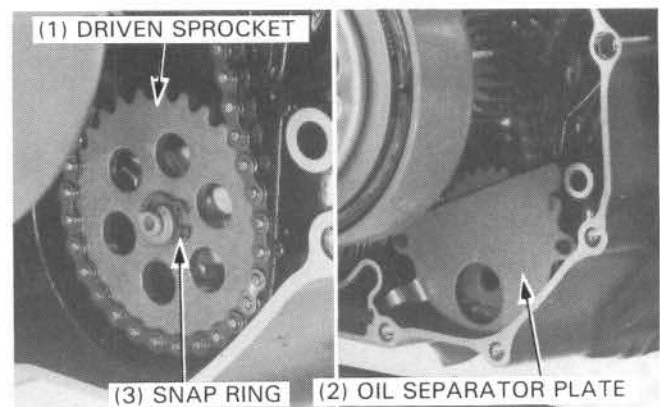

LUBRICATION POINTS

Use general purpose grease when no other specification is given. Apply oil or grease to any 2 sliding surfaces and cables not shown here.

CONTROL CABLES

Periodically, disconnect the throttle and brake cables at their upper ends. Thoroughly lubricate the cables and their pivot points with a commercially available cable lubricant or light weight oil.

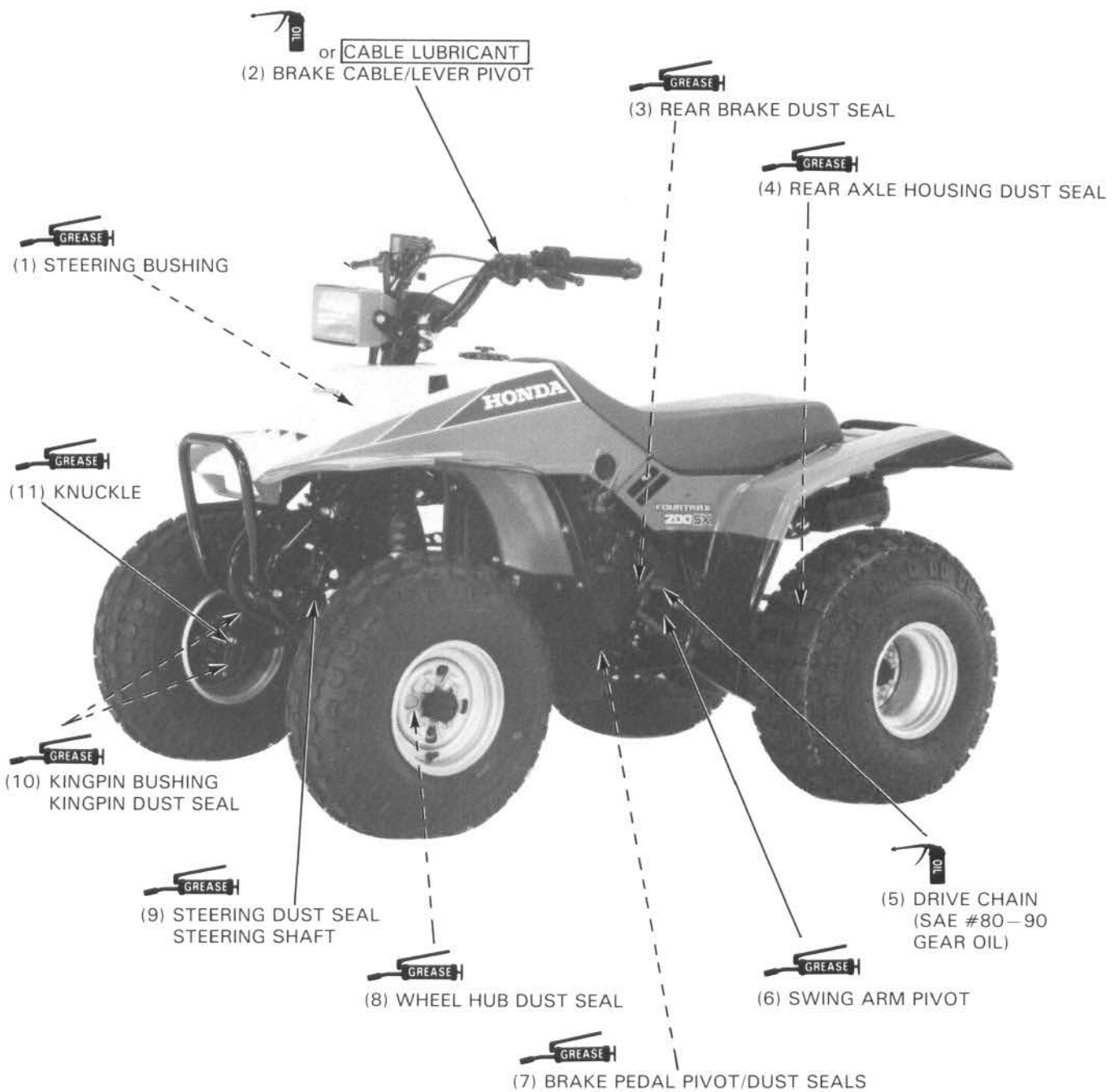

MEMO

RIDE RED

SERVICE INFORMATION	3-1	DRIVE CHAIN	3-7
MAINTENANCE SCHEDULE	3-2	BRAKE FLUID	3-8
FUEL LINE	3-3	BRAKE SHOE WEAR	3-8
FUEL STRAINER SCREEN	3-3	BRAKE SYSTEM	3-9
THROTTLE OPERATION	3-3	REVERSE LOCK SYSTEM	3-10
CARBURETOR CHOKE	3-4	CLUTCH SYSTEM	3-11
AIR CLEANER	3-4	SUSPENSION	3-11
SPARK PLUG	3-5	SPARK ARRESTER	3-11
VALVE CLEARANCE	3-6	NUT, BOLT, FASTENER	3-12
CARBURETOR IDLE SPEED	3-6	WHEELS/TIRES	3-12
CYLINDER COMPRESSION	3-7	STEERING SYSTEM	3-12

SERVICE INFORMATION

SPECIFICATIONS

Throttle lever free play		3–8 mm (1/8–5/16 in)
Recommended spark plug		DR8ES-L (NGK) X24ESR-U (ND)
Spark plug gap		0.6–0.7 mm (0.024–0.028 in)
Valve clearance	Intake/Exhaust	0.08 mm (0.003 in)
Idle speed		1,400 ± 100 rpm
Cylinder compression		1,300 ± 100 kPa (13.0 ± 1.0 kg/cm ² , 184 ± 14 psi)
Drive chain slack		30–35 mm (1-3/16–1-3/8 in)
Front brake lining thickness	Standard	4.0 mm (0.16 in)
	Service limit	2.0 mm (0.08 in)
Front brake lever free play		25–30 mm (1–1-3/16 in)
Rear brake lever free play		15–20 mm (5/8–3/4 in)
Rear brake pedal free play		15–20 mm (5/8–3/4 in)
Reverse selector lever free play		2–4 mm (1/16–1/8 in)
Recommended tire pressure	Front	3.0 psi (21 kPa, 0.21 kg/cm ²)
	Rear	2.4 psi (17 kPa, 0.17 kg/cm ²)
Maximum tire pressure	Front	3.4 psi (24 kPa, 0.24 kg/cm ²)
	Rear	2.8 psi (20 kPa, 0.20 kg/cm ²)
Minimum tire pressure	Front	2.6 psi (18 kPa, 0.18 kg/cm ²)
	Rear	2.0 psi (14 kPa, 0.14 kg/cm ²)
Standard tire circumference	Front	1,594 mm (62.8 in)
	Rear	1,756 mm (69.1 in)
Front wheel	Toe-in	10 ± 10 mm (0.39 ± 0.39 in)

TORQUE VALUES

Fuel cup	3–5 N·m (0.3–0.5 kg-m, 2–4 ft-lb)
Spark plug	12–19 N·m (1.2–1.9 kg-m, 9–14 ft-lb)
Rear axle housing lock bolt	80–100 N·m (8.0–10.0 kg-m, 58–72 ft-lb)
Clutch adjusting screw lock nut	19–25 N·m (1.9–2.5 kg-m, 14–18 ft-lb)

MAINTENANCE

MAINTENANCE SCHEDULE

Perform the Pre-ride Inspection in the Owner's Manual at each scheduled maintenance period.



I: Inspect and clean, adjust, lubricate, or replace if necessary.

C: Clean

R: Replace

A: Adjust

L: Lubricate

ITEM	FREQUENCY	WHICHEVER COMES FIRST	INITIAL SERVICE PERIOD (First week of operation)	REGULAR SERVICE PERIOD (Every 30 operating days)	Refer to page
		  EVERY			
* FUEL LINE		YEAR I			3-3
* FUEL STRAINER SCREEN		YEAR C			3-3
* THROTTLE OPERATION			I	I	3-3
* CARBURETOR CHOKE				I	3-4
AIR CLEANER		NOTE 1		C	3-4
SPARK PLUG				I	3-5
* VALVE CLEARANCE			I	I	3-6
ENGINE OIL			R	R	2-2
* ENGINE OIL CENTRIFUGAL FILTER				C	2-2
* ENGINE OIL STRAINER SCREEN				C	2-2
* CARBURETOR IDLE SPEED			I	I	3-6
DRIVE CHAIN		NOTE 1	I, L	I, L	3-7
BRAKE FLUID		2 YEARS R		I	3-8
* BRAKE SHOE WEAR		YEAR I, NOTE 2			3-8
BRAKE SYSTEM			I	I	3-9
* REVERSE LOCK SYSTEM			I	I	3-10
* CLUTCH SYSTEM			I	I	3-11
* SUSPENSION				I, L	3-11
* SPARK ARRESTER (U.S.A. only)				C	3-11
* NUT, BOLT, FASTENER			I	I	3-12
** WHEEL			I	I	3-12
** STEERING SYSTEM		YEAR I			3-12

* Should be serviced by an authorized Honda dealer, unless the owner has proper tools and service data and is mechanically qualified.

** In the interest of safety, we recommended these items be serviced only by an authorized Honda dealer.

NOTES: 1. Service more frequently when riding in dusty areas, sand or snow.
2. Service more frequently after riding in very wet or muddy conditions.

FUEL LINE

Remove the seat.

Check the fuel line.

Replace any parts which show signs of deterioration, damage or leaks.

Install the seat.

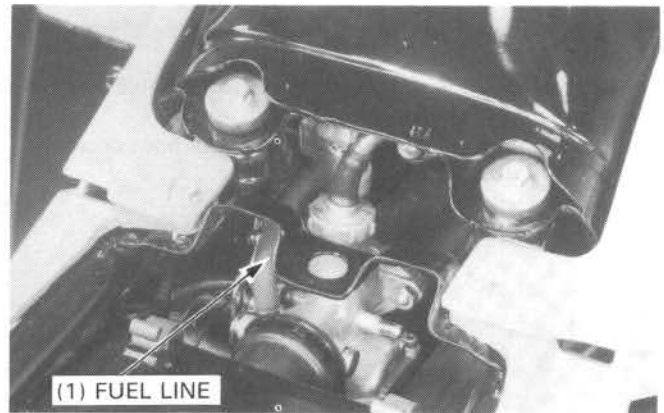

FUEL STRAINER SCREEN

Turn the fuel valve off.

Remove the fuel cup, O-ring and strainer screen, and drain the gasoline into a suitable container.

WARNING

- *Gasoline is flammable and is explosive under certain conditions. Do not smoke or allow flames or sparks near the equipment while draining fuel.*

Wash the cup and strainer screen in clean non-flammable or high flash point solvent.

Reinstall the strainer screen, aligning the index marks on the fuel valve body and strainer screen.

Install a new O-ring into the fuel valve body.

Reinstall the fuel cup, making sure the O-ring is in place.

Hand tighten the fuel cup and then torque it to specification.

TORQUE: 3–5 N·m (0.3–0.5 kg·m, 2–4 ft·lb)

CAUTION

- *Do not overtighten the fuel cup.*

After installing, turn the fuel valve ON and check that there are no fuel leaks.

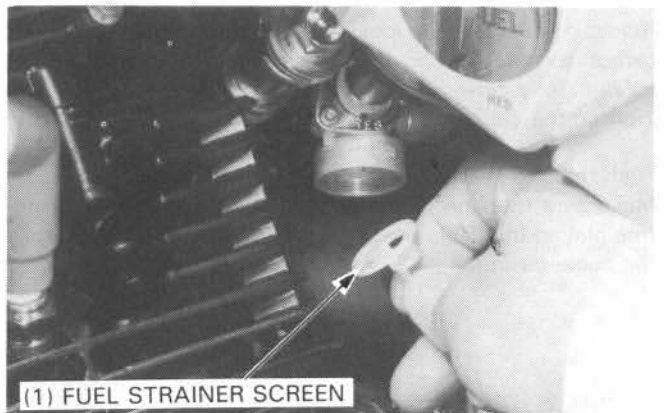
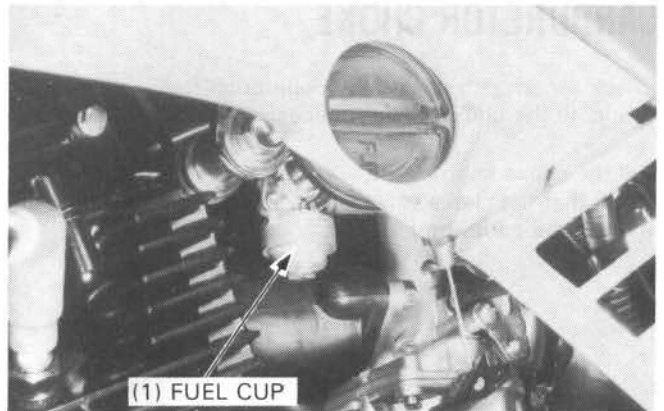

THROTTLE OPERATION

Check for smooth throttle lever full opening and automatic full closing in all steering positions. Make sure there is no deterioration, damage or kinking in the throttle cable. Replace any damaged parts.

Disconnect the throttle cable at the upper end.

Thoroughly lubricate the cable and pivot point with a commercially available cable lubricant to prevent premature wear.

Install the throttle cable in the reverse order of removal.

Make sure the throttle lever free play is 3–8 mm (1/8–5/16 in) at the tip of the throttle lever.

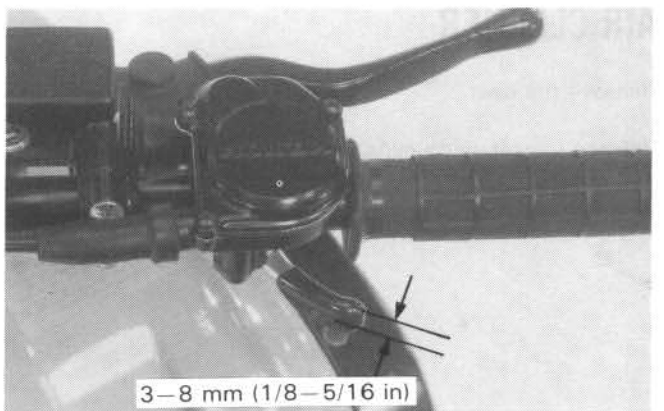

MAINTENANCE

Adjust as follows:

Slide the rubber boot off the cable adjuster.

Loosen the lock nut and adjust the throttle cable free play by turning the cable adjuster.

Tighten the lock nut and install the rubber boot securely.

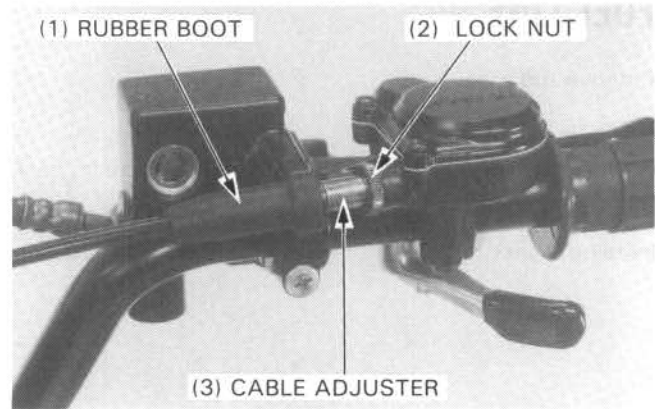

CARBURETOR CHOKE

Check for smooth choke knob operation.

Lubricate the choke cable if necessary.

Pull the choke knob all the way up to fully closed position and check that the choke valve is fully closed by moving the choke lever at the carburetor.

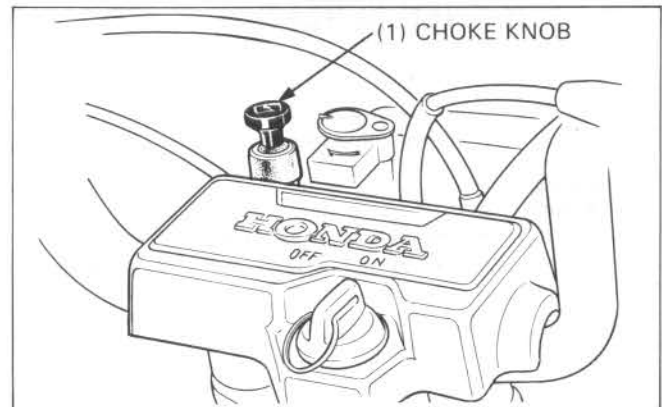

Adjust if necessary, by loosening the choke cable clamp on the carburetor and moving the choke cable casing so the choke valve is fully closed. Tighten the clamp.

Push the choke knob all the way in to the fully open position. Make sure that the choke valve is fully open by checking for free play in the cable between the lever on the carburetor and the cable casing.

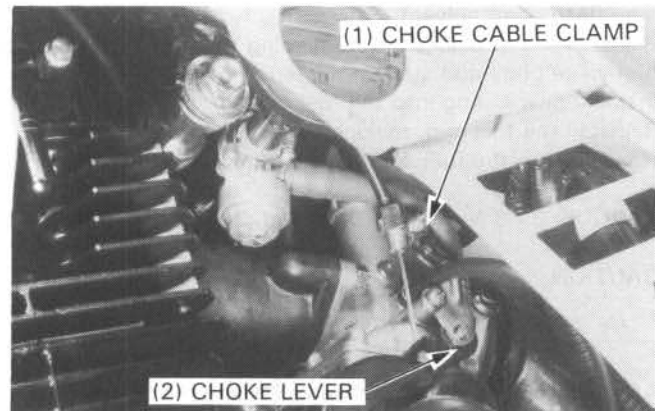

AIR CLEANER

Remove the seat.

Release the retaining clips holding the air cleaner case cover, and remove the air cleaner case cover.

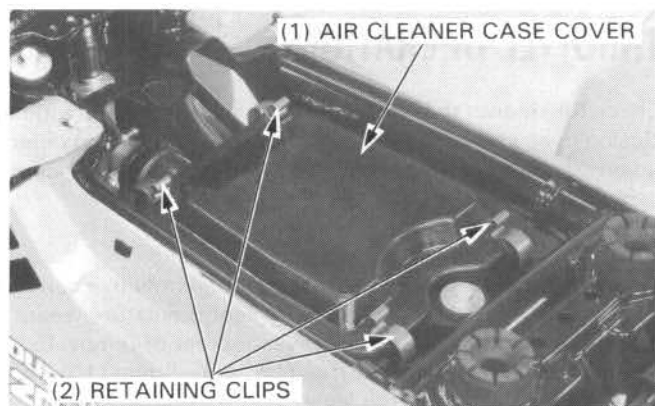



Download the full PDF manual instantly.

Our customer service e-mail:

aservicemanualpdf@yahoo.com