

## ENGINE FINDER

The following listings contain all engines covered in this manual

Model/Engine	Year
45 hp, 4 cyl, 2-stroke	1986 - 1989
50 hp, 3 cyl, 2-stroke	1986 - 1989
50 hp, 4 cyl, 2-stroke	1982 - 1985
60 hp, 3 cyl, 2-stroke	1984 - 1989
70 hp, 3 cyl, 2-stroke	1980 - 1983
75 hp, 3 cyl, 2-stroke	1987 - 1989
75 hp, 4 cyl, 2-stroke	1984 - 1986
80 hp, 4 cyl, 2-stroke	1978 - 1983
85 hp, 4 cyl, 2-stroke	1977
90 hp, 3 cyl, 2-stroke	1987 - 1989
90 hp, 6 cyl, 2-stroke	1979 - 1986
100 hp, 4 cyl, 2-stroke	1988 - 1989
115 hp, 4 cyl, 2-stroke	1989
115 hp, 6 cyl, 2-stroke	1978 - 1988
135 hp, V6, 2-stroke	1986 - 1989
140 hp, 6 cyl, 2-stroke	1978 - 1980
150 hp, V6, 2-stroke	1980 - 1989
175 hp, V6, 2-stroke	1979 - 1980
175 hp, V6, 2-stroke	1985 - 1989
200 hp, V6, 2-stroke	1980 - 1989
220 EFI, V6, 2-stroke	1987 - 1988

# TABLE OF CONTENTS

<b>1 SAFETY</b>			
INTRODUCTION	1-1		
CLEANING, WAXING, & POLISHING	1-1		
CONTROLLING CORROSION	1-2		
PROPELLERS	1-2		
FUEL SYSTEM	1-7		
LOADING	1-9		
HORSEPOWER	1-10		
FLOTATION	1-10		
EMERGENCY EQUIPMENT	1-12		
COMPASS	1-14		
ANCHORS	1-16		
MISCELLANEOUS EQUIPMENT	1-17		
BOATING ACCIDENT REPORTS	1-18		
NAVIGATION	1-18		
<b>2 TUNING</b>			
INTRODUCTION	2-1		
TUNE-UP SEQUENCE	2-2		
COMPRESSION CHECK	2-2		
SPARK PLUG INSPECTION	2-3		
IGNITION SYSTEM	2-4		
TIMING AND SYNCHRONIZING	2-4		
ELECTRICAL POWER SUPPLY	2-5		
CARBURETOR ADJUSTMENT	2-6		
ELECTRONIC FUEL INJECTION	2-9		
FUEL PUMPS	2-9		
OIL INJECTION	2-10		
CRANKING MOTOR AND SOLENOID	2-10		
INTERNAL WIRING HARNESS	2-11		
WATER PUMP CHECK	2-11		
PROPELLER	2-12		
LOWER UNIT	2-13		
BOAT TESTING	2-14		
<b>3 MAINTENANCE</b>			
INTRODUCTION	3-1		
OUTBOARD SERIAL NUMBERS	3-2		
LUBRICATION - COMPLETE UNIT	3-2		
PRE-SEASON PREPARATION	3-4		
FIBERGLASS HULLS	3-8		
BELOW WATERLINE SERVICE	3-9		
SUBMERGED ENGINE SERVICE	3-9		
PROPELLER SERVICE	3-12		
POWER TRIM/TILT	3-13		
INSIDE THE BOAT	3-15		
		LOWER UNIT	3-15
		WINTER STORAGE	3-16
		<b>4 FUEL</b>	
		INTRODUCTION	4-1
		GENERAL CARBURETION INFORMATION	4-2
		CARBURETOR IDENTIFICATION	4-4
		FUEL SYSTEM	4-5
		Leaded Gasoline & Gasohol	4-6
		Removing Fuel From System	4-6
		TROUBLESHOOTING	
		MODELS W/O EFI	4-7
		"Sour" Fuel	4-7
		Fuel Pump Test	4-9
		Fuel Line Test	4-11
		Rough Engine Idle	4-11
		Excessive Fuel Consumption	4-11
		Engine Surge	4-12
		Anti-Syphon Valve	4-12
		ENRICHENER SYSTEM	4-12
		"2+2" SYSTEM	4-13
		CARBURETOR "A" - "MERCARB" WITH OR WITHOUT INTEGRAL FUEL PUMP	4-14
		Removal & Disassembling	4-15
		Cleaning & Inspecting	4-18
		Assembling & Installation	4-20
		Adjustments	4-23
		CARBURETOR "B" CENTER SQUARE BOWL	4-23
		Removal & Disassembling	4-23
		Cleaning & Inspecting	4-26
		Assembling & Installation	4-28
		Adjustments	4-32
		CARBURETOR "C" - WME SERIES	4-33
		Removal & Disassembling	4-33
		Cleaning & Inspecting	4-36
		Assembling & Installation	4-37
		Adjustments	4-39
		CARBURETOR "D" SIDE BOWL AND BACK DRAG	4-39
		Removal & Disassembling	4-39
		Cleaning & Inspecting	4-42
		Assembling & Installation	4-44
		Adjustments	4-48

#### 4 FUEL (Continued)

CARBURETOR "E" V6 POWERHEADS	
DUAL FLOAT CENTER BOWL	4-49
Removal & Disassembling	4-49
Cleaning & Inspecting	4-51
Assembling & Installation	4-53
Adjustments	4-57

FUEL PUMP	
Theory of Operation	4-57
Pump Pressure Check	4-58
Pump Removal	4-58
Cleaning & Inspecting	4-59
Assembling	4-59

ELECTRONIC FUEL INJECTION	4-61
EFI SYSTEM DESCRIPTION	4-61
TROUBLESHOOTING EFI	4-69
MAINTENANCE -- EFI FUEL SYS.	4-76
Leaded Gasoline & Gasohol	4-76
Removing Fuel From System	4-77
SERVICING EFI	4-78
Intake Manifold and Fuel Injectors	4-78
Secondary Fuel Filter	4-89
Fuel Pressure Regulator and Vapor Separator	4-91
Throttle Sensor	4-95

#### 5 OIL INJECTION

INTRODUCTION	5-1
AUTO BLEND	
Description	5-2
Operation	5-3
Troubleshooting	5-3
System Storage	5-6
Preparation for Use	5-6
ADVANCED OIL INJECTION	
Description	5-7
Operation	5-10
Filling System	5-11
Bleeding System	5-11
Oil Pump Adjustment	5-12
Troubleshooting	5-12
Servicing	5-12
Removal	5-15
Disassembling	5-16
Cleaning and Inspecting	5-17
Assembling	5-19
Installation	5-22

#### 6 IGNITION

INTRODUCTION	6-1
SPARK PLUG EVALUATION	6-1

THUNDERBOLT -- DISTRIBUTOR CD -- POINTLESS	
Description	6-3
Troubleshooting	6-2
Servicing	6-7
Distributor Removal	6-7
Cleaning & Inspecting	6-8
Distributor Assembling	6-8

THUNDERBOLT -- FLYWHEEL -- CD -- COIL PER CYLINDER	
Description	6-11
Troubleshooting	6-11
Servicing	6-19
Removal	6-19
Cleaning and Inspecting	6-21
Assembling	6-22
IDLE STABILIZER AND SPARK ADVANCE MODULES	6-23
Operation	6-24
Troubleshooting	6-24

#### 7 TIMING AND SYNCHRONIZING

INTRODUCTION & PREPARATION	7-1
IGNITION TIMING & CARB. SYNCH.	7-3
IDLE STABILIZER AND SPARK ADVANCE MODULES	7-6

4-CYLINDER POWERHEADS	
MODEL 50HP - 1982-85	
MODEL 45HP - SINCE 1986	7-6

3-CYLINDER POWERHEADS	
MODEL 50HP - SINCE 1986	
MODEL 60HP - SINCE 1984	
MODEL 70HP - 1980-83	7-8

4-CYLINDER POWERHEADS	
MODEL 75HP - 1984-86	
MODEL 80HP - 1978-83	
MODEL 85HP - 1977 Only	7-10

3-CYLINDER POWERHEADS	
MODEL 75HP - SINCE 1987	
MODEL 90HP - SINCE 1987	7-11

4-CYLINDER POWERHEADS	
MODEL 100HP - SINCE 1988	
MODEL 115HP - SINCE 1989	7-14

6-CYLINDER IN-LINE POWERHEADS WITH DISTRIBUTOR	
MODEL 90HP	
MODEL 115HP	
MODEL 140HP	7-16

6-CYLINDER IN-LINE POWERHEADS WITHOUT DISTRIBUTOR MODEL 90HP MODEL 115HP MODEL 140HP	7-18
V6 POWERHEADS WITHOUT EFI MODEL 175HP S/N 4838074 to 6618750	7-21
MODEL 150HP S/N 5203428 AND BELOW MODEL 200HP S/N 5363917 AND BELOW	7-24
MODEL 135HP MODEL 150HP S/N 5203429 AND ABOVE MODEL 175 HP S/N 6618751 AND ABOVE MODEL 200HP S/N 5363918 TO 6073191	7-27
MODEL 200HP S/N 6073192 AND ABOVE	7-30
V6 POWERHEADS WITH EFI	7-33

## 8 POWERHEAD

CHAPTER ORGANIZATION	8-1
GENERAL POWERHEAD INFORMATION	8-2
COOLING LECTURE	8-4
CYLINDER DRAIN SYSTEM	8-6
REMOVAL AND DISASSEMBLING ORIGINAL DESIGN IN-LINE POWERHEADS	
MODEL 45 4-CYL. 1986 & ON	
MODEL 50 4-CYL. 1982-85	
MODEL 50 3-CYL. 1986 & ON	
MODEL 60 3-CYL. 1984 & ON	
MODEL 70 3-CYL. 1980-83	
MODEL 75 4-CYL. 1984-86	
MODEL 80 4-CYL. 1978-83	
MODEL 85 4-CYL. 1977	
MODEL 90 L6 1978-86	
MODEL 115 L6 1978-88	
MODEL 140 L6 1978-80	8-8
Removal	8-9
Disassembling	8-10
Assembling	8-14
Installation	8-27

## REDESIGNED IN-LINE POWERHEADS

MODEL 75 3-CYL. 1988 & ON	
MODEL 90 3-CYL. 1988 & ON	
MODEL 100 4-CYL. 1988 & ON	
MODEL 115 4-CYL. 1989 & ON	8-29
Removal	8-29
Disassembling	8-32
Assembling	8-46
Installation	8-58
V6 POWERHEAD	
Removal	8-62
Disassembling	8-63
Assembling	8-74
Installation	8-90
CLEANING AND INSPECTING	
ALL MODELS	8-95
Thermostat Service	8-95
Reed Block Service	8-96
Crankshaft Service	8-98
End Cap Bearings	8-99
Connecting Rod Service	8-100
Piston Service	8-102
Ring End Gap	8-103
Cylinder Block Service	8-104
Honing Procedures	8-105

## 9 ELECTRICAL

INTRODUCTION	9-1
BATTERIES	9-1
JUMPER CABLES	9-5
GAUGES AND HORNS	9-7
Temperature Gauges	9-8
Warning Lights	9-8
Fuel Gauges	9-9
Tachometer	9-11
Horns	9-11
ELECTRICAL SYSTEM	
GENERAL INFORMATION	9-12
CHARGING CIRCUIT SERVICE	9-13
Troubleshooting	9-14
Rectifier Removal	9-15
Rectifier Installation	9-17
STATOR SERVICE	9-17
Removal	9-18
Installation	9-18
CHOKE CIRCUIT	9-19
ENRICHENER SYSTEM	9-20
CRANKING MOTOR CIRCUIT	
Description & Operation	9-22
Troubleshooting	9-23
Removal	9-27

## 9 ELECTRICAL (Continued)

Disassembling - Pinion Gear with Rubber Cushion	9-28
Assembling	9-28
Disassembling - Pinion Gear with Snap Ring or Nut	9-29
Assembling	9-30
Disassembling - Pinion Gear with Top Spring	9-31
Assembling	9-32
CRANKING MOTOR REPAIR	9-32
Disassembling	9-33
Testing Parts	9-34
Cleaning & Inspecting	9-36
Assembling a Bosch	9-41
Assembling a Delco Remy	9-41
Assembling a Prestolite	9-46

## 10 TRIM/TILT

INTRODUCTION	10-1
CHAPTER ORGANIZATION	10-2
MECHANICAL TILT PIN	10-2
SYSTEM "A" -- TWO TRIM/TILT CYLINDERS	
Description and Operation	10-3
Special Instructions	10-5
Bleeding System "A"	10-6
Troubleshooting	10-7
Cleaning and Inspecting	10-9
System "A" Service	10-12
Pump Service	10-14
Electric Motor Service	10-17
SYSTEM "B" -- TWO TRIM CYLINDERS -- ONE TILT CYLINDER	
Description and Operation	10-21
Bleeding System "B"	10-22
Flushing	10-23
Troubleshooting	10-24
System "B" Service	10-31
Preliminary Tasks	10-31
Removal	10-33
Component Service	10-34
Manual Release Valve	10-34
Oil Reservoir Cover	10-35
Trim Cylinder	10-35
Tilt Cylinder	10-36
Electric Motor	10-36
Cleaning and Inspecting	10-37
Assembling & Installation	10-38

## SYSTEM "C" -- ONE TRIM/TILT CYLINDER

Description and Operation	10-53
Bleeding System "C"	10-54
Troubleshooting	10-54
System "C" Service	10-55
Pump Removal & Service	10-55
Cylinder Service	10-55

## 11 LOWER UNIT

DESCRIPTION	11-1
CHAPTER COVERAGE	11-1
TROUBLESHOOTING	11-5
LOWER UNIT REMOVAL	
ALL UNITS	11-6
Propeller Removal	11-7
WATER PUMP SERVICE	
Removal and Disassembling	
High Pressure Type Pump	11-9
High Volume Type Pump	11-10

## SERVICING CAM-SHIFT TYPE I UNITS MATCHED WITH EARLY 3-, 4-CYLINDER, L6 AND V6 POWERHEADS TO ABOUT 1979

Removal	11-12
Bearing Carrier and Propeller Shaft	11-13
Driveshaft & Bearing	11-14
Forward Gear & Bearing	11-16
Disassembling	
Bearing Carrier	11-17
Propeller Shaft	11-18
Driveshaft	11-18
Assembling	
Lower Driveshaft Bearing	11-23
Shift Shaft	11-23
Bearing Carrier	11-24
Forward Gear & Bearing	11-25
Forward Bearing Race	11-26
Driveshaft	11-27
Shimming & Backlash	
Pinion Gear Depth	11-29
Forward Gear Backlash	11-30
Reverse Gear Backlash	11-34
Assembling & Installation	
Bearing Carrier	11-33

## SERVICING CAM-SHIFT TYPE II UNITS MATCHED WITH LATE 3-, 4-CYLINDER, AND L6 POWERHEADS FROM ABOUT 1980

11-35

Removal and Disassembling		CLEANING AND INSPECTING	
Bearing Carrier	11-36	ALL UNITS	11-86
Propeller Shaft	11-37		
Shift Shaft	11-38	LOWER UNIT INSTALLATION	
Pinion Gear	11-39	Filling Lower Unit	11-88
Driveshaft	11-39	Assembling & Installation	11-89
Forward Gear	11-40	Propeller Installation	11-92
Pinion Gear Bearing Race	11-41		
Forward Bearing Race	11-41		
Driveshaft Bearing	11-41		
Assembling and Installation		<b>12 REMOTE CONTROLS</b>	
Driveshaft Bearing	11-44	INTRODUCTION	12-1
Pinion Gear Bearing Race	11-45	COMMANDER CONTROL BOX	
Forward Bearing Race	11-45	Removal & Disassembling	12-2
Shift Shaft	11-46	Cleaning & Inspecting	12-9
Forward Gear	11-46	Assembling & Installation	12-11
Driveshaft	11-47		
Pinion Gear	11-47		
Propeller Shaft	11-48		
Bearing Carrier	11-49	<b>13 HAND REWIND STARTER</b>	
Pinion Gear Depth	11-50	INTRODUCTION	13-1
Forward Gear Backlash	11-51		
		TYPE "A" (See Introduction)	13-2
<b>SERVICING E-Z SHIFT</b>		Removal and Disassembling	13-2
<b>MODELS SINCE ABOUT 1979</b>		Cleaning and Inspecting	13-4
Special Words	11-53	Assembling and Installation	13-6
Removal			
Bearing Carrier	11-53	TYPE "B" (See Introduction)	13-6
Propeller Shaft	11-55	Removal and Disassembling	13-13
Driveshaft & Bearing	11-56	Cleaning and Inspecting	13-16
Separate Forward Gear		Assembling and Installation	13-17
from Bearing	11-60		
Disassembling			
Driveshaft	11-60		
Separate Reverse Gear			
from Bearing Carrier	11-61		
Assembling & Installation		<b>APPENDIX</b>	
Lower Driveshaft Bearing	11-61	METRIC CONVERSION CHART	A-1
Bearing Carrier	11-61	ENGINE SPECIFICATIONS	
Forward Gear & Bearing	11-64	AND TUNE-UP ADJUSTMENTS	A-2
Forward Bearing Race	11-65	REED STOP OPENING	A-10
Propeller Shaft	11-66	PISTON AND CYLINDER SPECS.	A-11
Driveshaft	11-71	LOWER UNIT BACKLASH TABLE	A-12
Shimming		LOWER UNIT OIL CAPACITY	
Pinion Gear Depth	11-75	AND GEAR CHART	A-13
Forward Gear Backlash	11-76	CARBURETOR JET SIZE/	
Alpha Drive	11-78	ELEVATION CHARTS	A-14
<b>WATER PUMP ASSEMBLING AND</b>		<b>WIRE IDENTIFICATION DWGS.</b>	
<b>INSTALLATION</b>	11-81	Ignition Systems	A-17 thru A-24
High Pressure Type Pump	11-81	Type "B" Trim/Tilt	A-25
Shimming (Certain Units)	11-81	Type "C" Trim/Tilt	A-26
High Volume Type Pump	11-85	Commander Control Box	A-27

# 1 SAFETY

## 1-1 INTRODUCTION

In order to protect the investment for the boat and outboard, they must be cared for properly while being used and when out of the water. Always store the boat with the bow higher than the stern and be sure to remove the transom drain plug and the inner hull drain plugs. If any type of cover is used to protect the boat, be sure to allow for some movement of air through the hull. Proper ventilation will assure evaporation of any condensation that may form due to changes in temperature and humidity.

## 1-2 CLEANING, WAXING, AND POLISHING

Any boat should be washed with clear water after each use to remove surface dirt and any salt deposits from use in salt water. Regular rinsing will extend the time between waxing and polishing. It will also give you "pride of ownership", by having a sharp looking piece of equipment. Elbow grease, a mild detergent, and a brush will be required to remove stubborn dirt, oil, and other unsightly deposits.

Stay away from harsh abrasives or strong chemical cleaners. A white buffing com-



*A clean boat, properly tuned outboard unit, and attention to sensible safety practices are what make: "The worst day fishin' better than the best day workin'!"*

## 1-2 SAFETY

pound can be used to restore the original gloss to a scratched, dull, or faded area. The finish of your boat should be thoroughly cleaned, buffed, and polished at least once each season. Take care when buffing or polishing with a marine cleaner not to over-heat the surface you are working, because you will burn it.

## 1-3 CONTROLLING CORROSION

Since man first started out on the water, corrosion on his craft has been his enemy. The first form was merely rot in the wood and then it was rust, followed by other forms of destructive corrosion in the more modern materials. One defense against corrosion is to use similar metals throughout the boat. Even though this is difficult to do in designing a new boat, particularly the undersides, similar metals should be used whenever and wherever possible.

A second defense against corrosion is to insulate dissimilar metals. This can be done by using an exterior coating of Sea Skin or by insulating them with plastic or rubber gaskets.

### Using Zinc

The proper amount of zinc attached to a boat is extremely important. The use of too much zinc can cause wood burning by placing the metals close together and they become "hot". On the other hand, using too small a zinc plate will cause more rapid deterioration of the metal you are trying to protect. If in doubt, consider the fact that it is far better to replace the zincs than to replace planking or other expensive metal parts from having an excess of zinc.

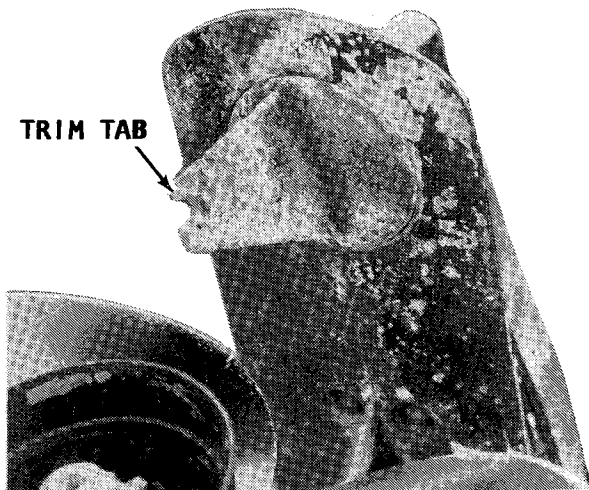

Zinc installation also used as the trim tab. The tab assists the helmsperson to maintain a true course without "fighting" the wheel.

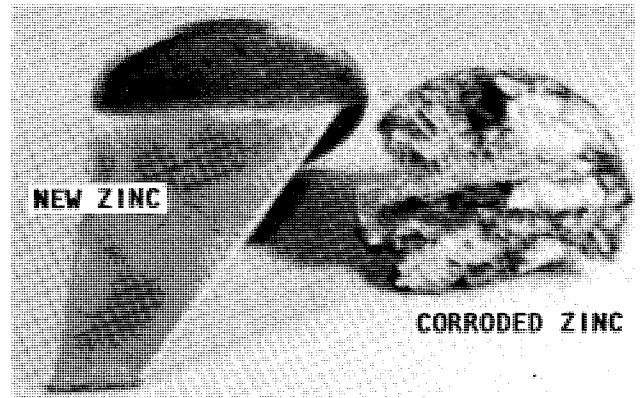

A new trim tab zinc, left, and a corroded zinc, right. An excellent example of the inexpensive zinc saving more costly parts of the outboard unit.

When installing zinc plates, there are two routes available. One is to install many different zincs on all metal parts and thus run the risk of wood burning. Another route, is to use one large zinc on the transom of the boat and then connect this zinc to every underwater metal part through internal bonding. Of the two choices, the one zinc on the transom is the better way to go.

Small outboard engines have a zinc plate attached to the cavitation plate. Therefore, the zinc remains with the engine at all times.

## 1-4 PROPELLERS

As you know, the propeller is actually what moves the boat through the water. This is how it is done. The propeller operates in water in much the manner as a wood screw does in wood. The propeller "bites" into the water as it rotates. Water passes between the blades and out to the rear in the shape of a cone. The propeller "biting" through the water in much the same manner as a wood auger is what propels the boat.

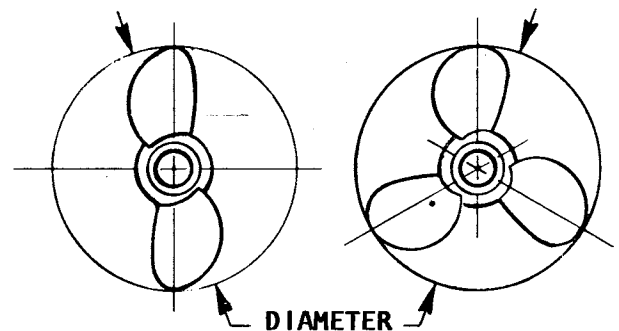

Diameter and pitch are the two basic dimensions of a propeller. The diameter is measured across the circumference of a circle scribed by the propeller blades, as shown.



**Diameter and Pitch**

Only two dimensions of the propeller are of real interest to the boat owner: the diameter and the pitch. These two dimensions are stamped on the propeller hub and always appear in the same order: the diameter first and then the pitch. For instance, the number 15-19 stamped on the hub, would mean the propeller had a diameter of 15 inches with a pitch of 19.

The diameter is the measured distance from the tip of one blade to the tip of the other as shown in the accompanying illustration.

The pitch of a propeller is the angle at which the blades are attached to the hub. This figure is expressed in inches of water travel for each revolution of the propeller. In our example of a 15-19 propeller, the propeller should travel 19 inches through the water each time it revolves. If the propeller action was perfect and there was no slippage, then the pitch multiplied by the propeller rpms would be the boat speed.

Most outboard manufacturers equip their units with a standard propeller with a diameter and pitch they consider to be best suited to the engine and the boat. Such a propeller allows the engine to run as near to the rated rpm and horsepower (at full throttle) as possible for the boat design.

The blade area of the propeller determines its load-carrying capacity. A two-blade propeller is used for high-speed running under very light loads.

A four-blade propeller is installed in boats intended to operate at low speeds under very heavy loads such as tugs, barges, or large houseboats. The three-blade propeller is the happy medium covering the wide range between the high performance units and the load carrying workhorses.

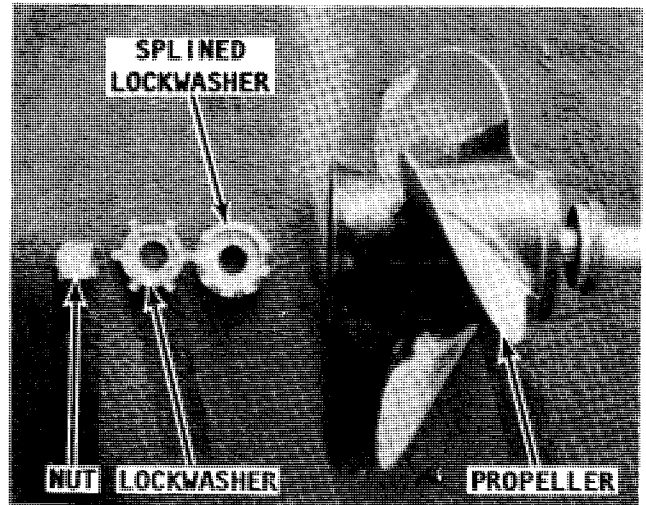

*Typical attaching hardware for a propeller.*

**Propeller Selection**

There is no standard propeller that will do the proper job in very many cases. The list of sizes and weights of boats is almost endless. This fact coupled with the many boat-engine combinations makes the propeller selection for a specific purpose a difficult job. In fact, in many cases the propeller is changed after a few test runs. Proper selection is aided through the use of charts set up for various engines and boats. These charts should be studied and understood when buying a propeller. However, bear in mind, the charts are based on average boats with average loads, therefore, it may be necessary to make a change in size or pitch, in order to obtain the desired results for the hull design or load condition.

Propellers are available with a wide range of pitch. Remember, a low pitch takes a smaller bite of the water than the high pitch propeller. This means the low pitch propeller will travel less distance through the water per revolution. The low

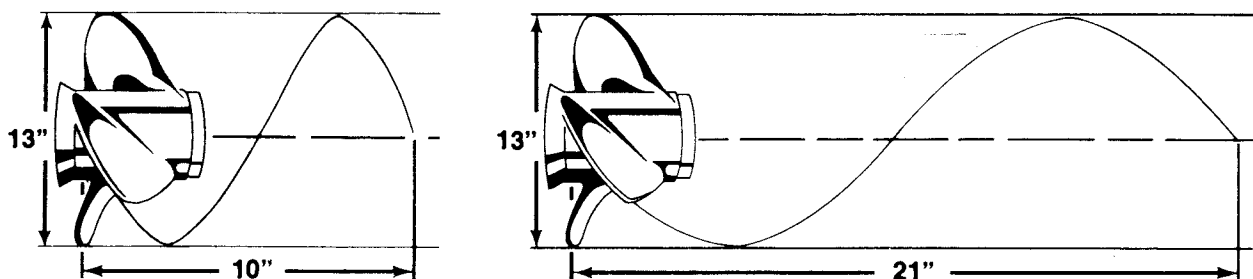

*Diagram to explain the pitch dimension of a propeller. The pitch is the theoretical distance a propeller would travel through water if there were no friction.*

## 1-4 SAFETY

pitch will require less horsepower and will allow the engine to run faster.

All engine manufacturers design their units to operate with full throttle at, or slightly above, the rated rpm. If you run your engine at the rated rpm, you will increase spark plug life, receive better fuel economy, and obtain the best performance from your boat and engine. Therefore, take time to make the proper propeller selection for the rated rpm of your engine at full throttle with what you consider to be an average load. Your boat will then be correctly balanced between engine and propeller throughout the entire speed range.

A reliable tachometer must be used to measure engine speed at full throttle to ensure the engine will achieve full horsepower and operate efficiently and safely. To test for the correct propeller, make your run in a body of smooth water with the lower unit in forward gear at full throttle. If the reading is above the manufacturer's recommended operating range, you must try propellers of greater pitch, until you find the one that allows the engine to operate continually within the recommended full throttle range.

If the engine is unable to deliver top performance and you feel it is properly tuned, then the propeller may not be to blame. Operating conditions have a marked effect on performance. For instance, an

engine will lose rpm when run in very cold water. It will also lose rpm when run in salt water as compared with fresh water. A hot, low-barometer day will also cause your engine to lose power.

### Cavitation

Cavitation is the forming of voids in the water just ahead of the propeller blades. Marine propulsion designers are constantly fighting the battle against the formation of these voids due to excessive blade tip speed and engine wear. The voids may be filled with air or water vapor, or they may actually be a partial vacuum. Cavitation may be caused by installing a piece of equipment too close to the lower unit, such as the knot indicator pickup, depth sounder, or bait tank pickup.

### Vibration

Your propeller should be checked regularly to be sure all blades are in good condition. If any of the blades become bent or nicked, this condition will set up vibrations in the drive unit and the motor. If the vibration becomes very serious it will cause a loss of power, efficiency, and boat performance. If the vibration is allowed to continue over a period of time it can have a damaging effect on many of the operating parts.

Vibration in boats can never be completely eliminated, but it can be reduced by keeping all parts in good working condition and through proper maintenance and lubrication. Vibration can also be reduced in

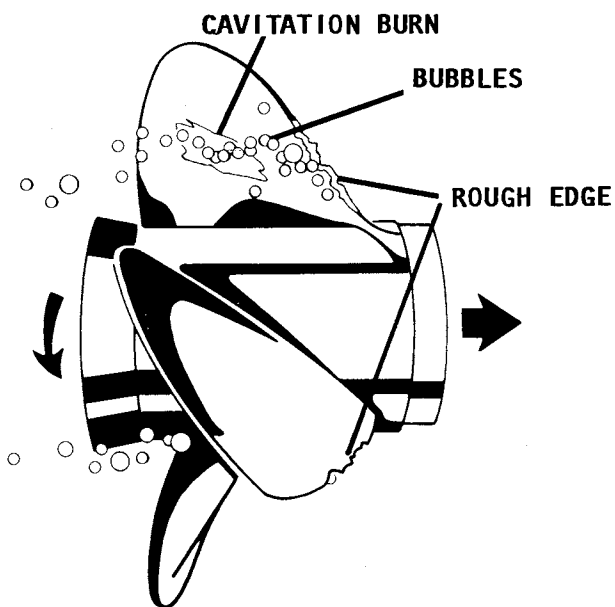

*Cavitation (air bubbles) formed at the propeller. Manufacturers are constantly fighting this problem, as explained in the text.*

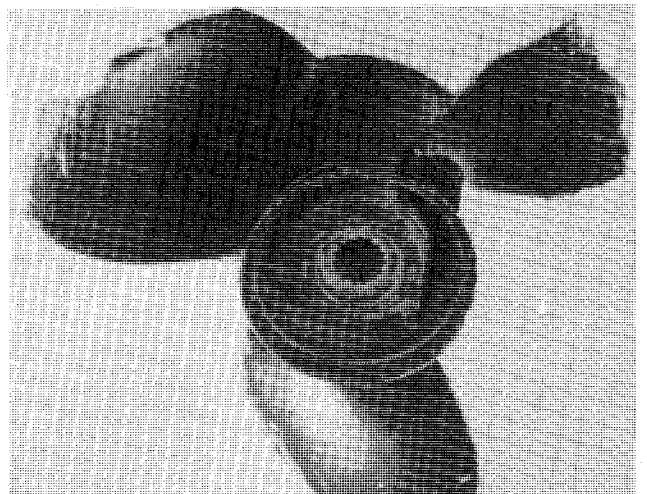

*Example of a damaged propeller. This unit should have been replaced long before this amount of damage was sustained.*

some cases by increasing the number of blades. For this reason, many racers use two-blade props and luxury cruisers have four- and five-blade props installed.

**Shock Absorbers**

The shock absorber in the propeller plays a very important role in protecting the shafting, gears, and engine against the shock of a blow, should the propeller strike an underwater object. The shock absorber allows the propeller to stop rotating at the instant of impact while the power train continues turning.

How much impact the propeller is able to withstand, before causing the shock absorber to slip, is calculated to be more than the force needed to propel the boat, but less than the amount that could damage any part of the power train. Under normal propulsion loads of moving the boat through the water, the hub will not slip. However, it will slip if the propeller strikes an object with a force that would be great enough to stop any part of the power train.

If the power train was to absorb an impact great enough to stop rotation, even

for an instant, something would have to give and be damaged. If a propeller is subjected to repeated striking of underwater objects, it would eventually slip on its clutch hub under normal loads. If the propeller should start to slip, a new shock absorber/cushion hub would have to be installed.

**Propeller Rake**

If a propeller blade is examined on a cut extending directly through the center of the hub, and if the blade is set vertical to the propeller hub, as shown in the accompanying illustration, the propeller is said to have a zero degree ( $0^{\circ}$ ) rake. As the blade slants back, the rake increases. Standard propellers have a rake angle from  $0^{\circ}$  to  $15^{\circ}$ .

A higher rake angle generally improves propeller performance in a cavitating or ventilating situation. On lighter, faster boats, higher rake often will increase performance by holding the bow of the boat higher.

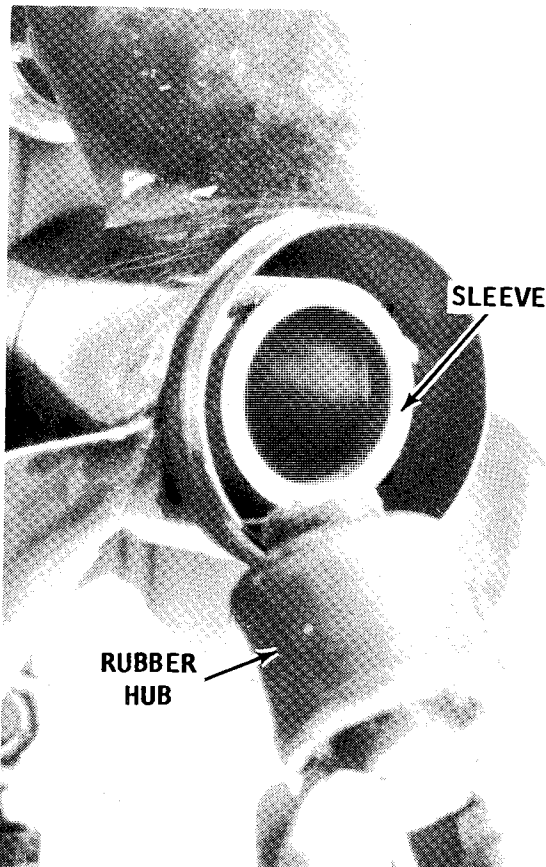

Rubber hub removed from the propeller because the hub was slipping in the propeller.

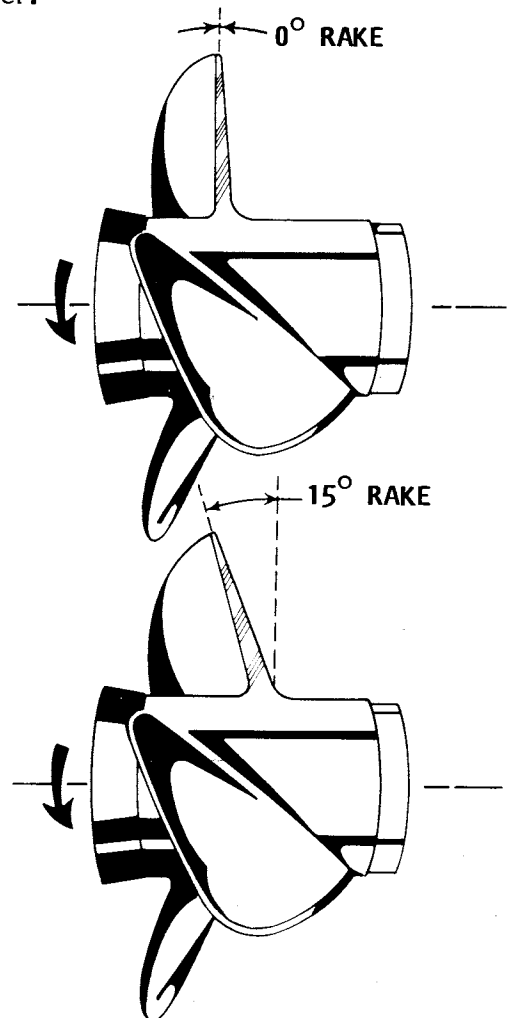
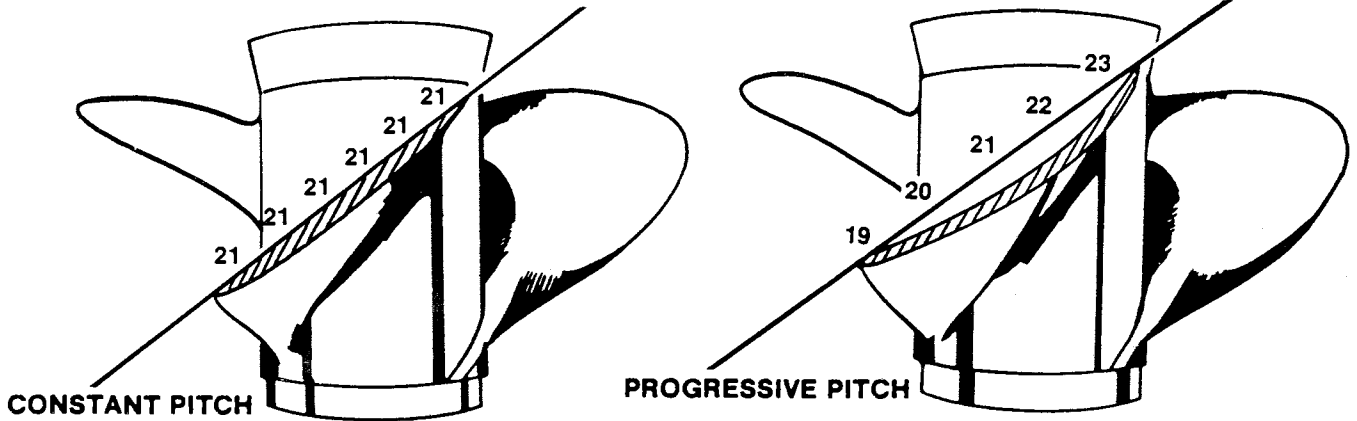

Illustration depicting the rake of a propeller, as explained in the text.



Comparison of a constant and progressive pitch propeller. Notice how the pitch of the progressive pitch propeller, right, changes to give the blade more thrust and therefore, the boat more speed.

### Progressive Pitch

Progressive pitch is a blade design innovation that improves performance when forward and rotational speed is high and/or the propeller breaks the surface of the water.

Progressive pitch starts low at the leading edge and progressively increases to the trailing edge, as shown in the accompanying illustration. The average pitch over the entire blade is the number assigned to that propeller. In the illustration of the progressive pitch, the average pitch assigned to the propeller would be 21.

### Cupping

If the propeller is cast with an edge curl inward on the trailing edge, the blade is said to have a cup. In most cases, cupped blades improve performance. The cup helps the blades to "HOLD" and not break loose, when operating in a cavitating or ventilating situation.

The cup has the effect of adding to the propeller pitch. Cupping usually will reduce full-throttle engine speed about 150 to 300 rpm below the same pitch propeller without a cup to the blade. A propeller repair shop is able to increase or decrease the cup on the blades. This change, as explained, will alter engine rpm to meet specific operating demands. Cups are rapidly becoming standard on propellers.

In order for a cup to be the most effective, the cup should be completely concave (hollowed) and finished with a sharp corner. If the cup has any convex rounding, the effectiveness of the cup will be reduced.

### Rotation

Propellers are manufactured as right-hand rotation (RH), and as left-hand rotation (LH). The standard propeller for out-

board units is RH rotation.

A right-hand propeller can easily be identified by observing it as shown in the accompanying illustration. Observe how the blade of the right-hand propeller slants from the lower left to upper right. The left-hand propeller slants in the opposite direction, from lower right to upper left.

When the RH propeller is observed rotating from astern the boat, it will be rotating clockwise when the engine is in forward gear. The left-hand propeller will rotate counterclockwise.

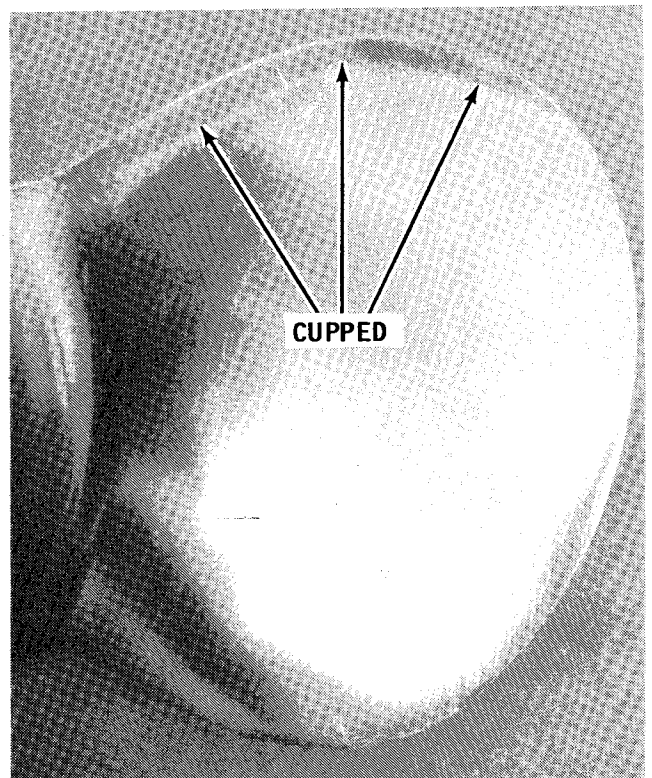

Propeller with a "cupped" leading edge. "Cupping" gives the propeller a better "hold" in the water.

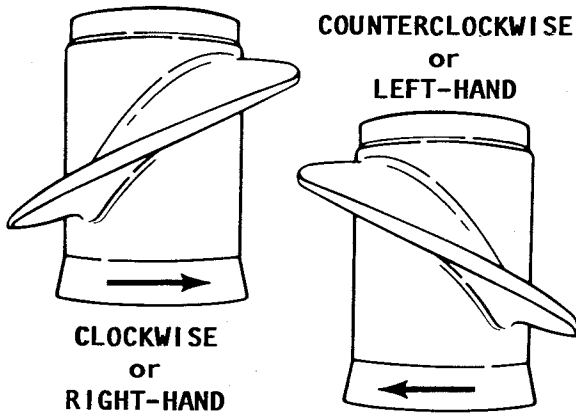

Right- and left-hand propellers showing how the angle of the blades is reversed. Right-hand propellers are by far the most popular for outboard units.

**1-5 FUEL SYSTEM**

**With Built-in Fuel Tank**

All parts of the fuel system should be selected and installed to provide maximum service and protection against leakage. Reinforced flexible sections should be installed in fuel lines where there is a lot of motion,

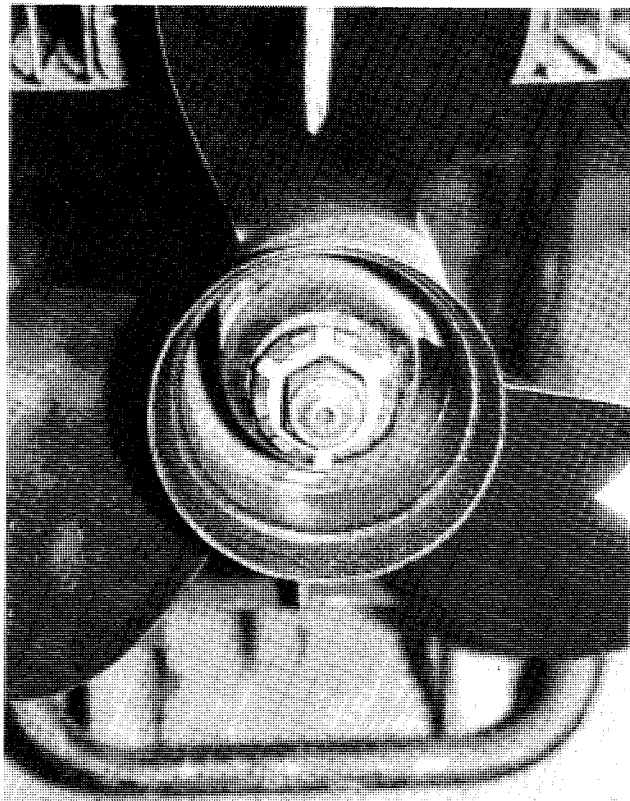

Typical propeller exhaust hub. This arrangement of exhaust gases passing through the hub results in a much quieter engine operation and the fumes are buried far behind the boat.

such as at the engine connection. The flaring of copper tubing should be annealed after it is formed as a protection against hardening.

**CAUTION:** Compression fittings should NOT be used because they are so easily overtightened, which places them under a strain and subjects them to fatigue. Such conditions will cause the fitting to leak after it is connected a second time.

The capacity of the fuel filter must be large enough to handle the demands of the engine as specified by the engine manufacturer.

A manually-operated valve should be installed if anti-siphon protection is not provided. This valve should be installed in the fuel line as close to the gas tank as possible. Such a valve will maintain anti-siphon protection between the tank and the engine.

The supporting surfaces and hold-downs must fasten the tank firmly and they should be insulated from the tank surfaces. This insulation material should be non-abrasive and nonabsorbent material. Fuel tanks installed in the forward portion of the boat should be especially well secured and protected because shock loads in this area can be as high as 20 to 25 g's ("g" equals force of gravity).

**Taking On Fuel**

The fuel tank of the boat should be kept full to prevent water from entering the system through condensation caused by temperature changes. Water droplets forming is one of the greatest enemies of the fuel system. By keeping the tank full, the air space in the tank is kept to an absolute minimum and there is no room for moisture to form. It is a good practice not to store

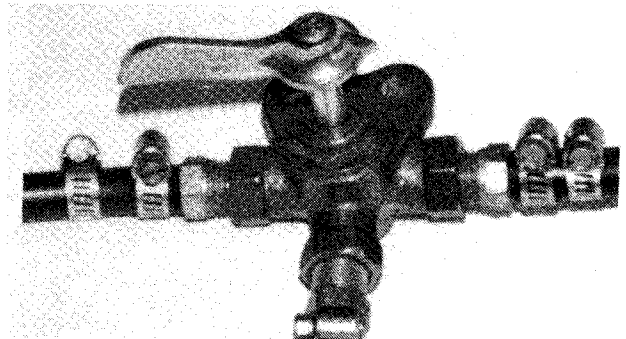

A three-position valve permits fuel to be drawn from either of two tanks or shut off completely. Such an arrangement prevents accidental siphoning of fuel from the tank. The inside diameter of the valve should be at 5/16" (7.94mm).

fuel in the tank over an extended period, say for six months. Today, fuels contain ingredients that change into gums when stored for any length of time. These gums and varnish products will cause carburetor problems and poor spark plug performance. An additive (Sta-Bil) is available and can be used to prevent gums and varnish from forming.

**Static Electricity**

In very simple terms, static electricity is called frictional electricity. It is generated by two dissimilar materials moving over each other. One form is gasoline flowing through a pipe or into the air. Another form is when you brush your hair or walk across a synthetic carpet and then touch a metal object. All of these actions cause an electrical charge. In most cases, static electricity is generated during very dry weather conditions, but when you are filling the fuel tank on a boat it can happen at any time.

**Fuel Tank Grounding**

One area of protection against the build-up of static electricity is to have the fuel tank properly grounded (also known as bonding). A direct metal-to-metal contact from the fuel hose nozzle to the water in which

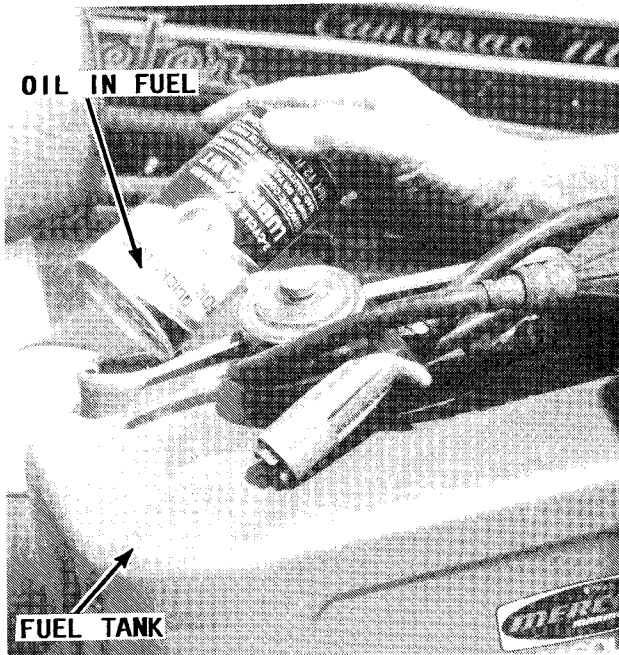

Any tank should contain some fuel when taking on fuel before oil is added. Just a little fuel will prevent the oil from accumulating on the bottom surface of the tank.

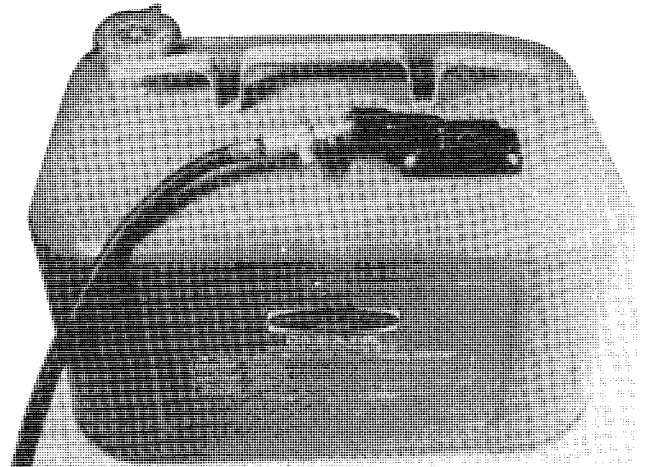

An approved fuel tank equipped with a quick-disconnect fitting. This type arrangement is handy when the tank must be removed from the boat to obtain fuel.

the boat is floating. If the fill pipe is made of metal, and the fuel nozzle makes a good contact with the deck plate, then a good ground is made.

As an economy measure, some boats use rubber or plastic filler pipes because of compound bends in the pipe. Such a fill line does not give any kind of ground and if your boat has this type of installation and you do not want to replace the filler pipe with a metal one, then it is possible to connect the deck fitting to the tank with a copper wire. The wire should be 8 gauge or larger.

The fuel line from the tank to the engine should provide a continuous metal-to-metal contact for proper grounding. If any part of this line is plastic or other non-metallic material, then a copper wire must be connected to bridge the non-metal material. The power train provides a ground through the engine and drive shaft, to the propeller in the water.

Fiberglass fuel tanks pose problems of their own. Fortunately, this material has almost totally disappeared as a suitable substance for fuel tanks. If, however, the boat you are servicing, does have a fiberglass tank, or one is being installed, or repaired, it is almost mandatory that you check with the Coast Guard Recreational Boating Standards Office in your district before proceeding with any work. The new standards are very specific and the Coast Guard is extremely rigid about enforcing the regulations.

Anything you can feel as a "shock" is enough to set off an explosion. Did you know that under certain atmospheric con-

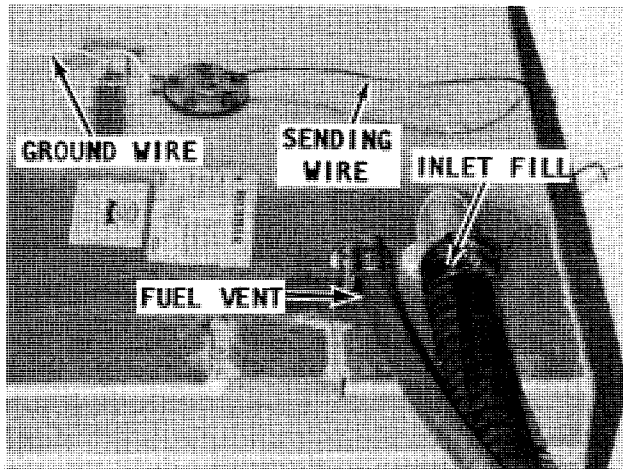

A fuel tank properly grounded to prevent static electricity. Static electricity could be extremely dangerous when taking on fuel.

ditions you can cause a static explosion yourself, particularly if you are wearing synthetic clothing. It is almost a certainty you could cause a static spark if you are **NOT** wearing insulated rubber-soled shoes.

As soon as the deck fitting is opened, fumes are released to the air. Therefore, to be safe you should ground yourself before opening the fill pipe deck fitting. One way to ground yourself is to dip your hand in the water overside to discharge the electricity in your body before opening the filler cap. Another method is to touch the engine block or any metal fitting on the dock which goes down into the water.

## 1-6 LOADING

In order to receive maximum enjoyment, with safety and performance, from your boat, take care not to exceed the load capacity given by the manufacturer. A plate attached to the hull indicates the U.S.

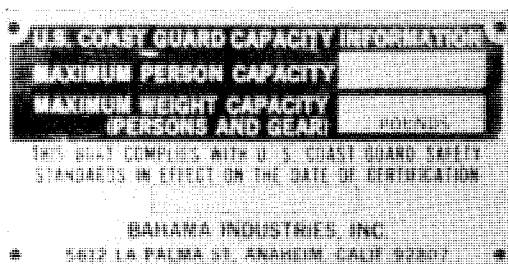

U.S. Coast Guard plate affixed to all new boats. When the blanks are filled in, the plate will indicate the Coast Guard's recommendations for persons, gear, and horsepower to ensure safe operation of the boat. These recommendations should not be exceeded, as explained in the text.

Coast Guard capacity information in pounds for persons and gear. If the plate states the maximum person capacity to be 750 pounds and you assume each person to weigh an average of 150 lbs., then the boat could carry five persons safely. If you add another 250 lbs. for motor and gear, and the maximum weight capacity for persons and gear is 1,000 lbs. or more, then the five persons and gear would be within the limit.

Try to load the boat evenly port and starboard. If you place more weight on one side than on the other, the boat will list to the heavy side and make steering difficult. You will also get better performance by placing heavy supplies aft of the center to keep the bow light for more efficient planing.

## Clarification

Much confusion arises from the terms, certification, requirements, approval, regulations, etc. Perhaps the following may clarify a couple of these points.

1- The Coast Guard does not approve boats in the same manner as they "Approve" life jackets. The Coast Guard applies a formula to inform the public of what is safe for a particular craft.

2- If a boat has to meet a particular regulation, it must have a Coast Guard certification plate. The public has been led to believe this indicates approval of the Coast Guard. Not so.

3- The certification plate means a willingness of the manufacturer to meet the Coast Guard regulations for that particular craft. The manufacturer may recall a boat if it fails to meet the Coast Guard requirements.

4- The Coast Guard certification plate, see accompanying illustration, may or may not be metal. The plate is a regulation for the manufacturer. It is only a warning plate and the public does not have to adhere to the restrictions set forth on it. Again, the plate sets forth information as to the Coast Guard's opinion for safety on that particular boat.

5- Coast Guard Approved equipment is equipment which has been approved by the Commandant of the U.S. Coast Guard and has been determined to be in compliance with Coast Guard specifications and regulations relating to the materials, construction, and performance of such equipment.



## I-10 SAFETY

### I-7 HORSEPOWER

The maximum horsepower engine for each individual boat should not be increased by any great amount without checking requirements from the Coast Guard in your area. The Coast Guard determines horsepower requirements based on the length, beam, and depth of the hull. **TAKE CARE NOT** to exceed the maximum horsepower listed on the plate or the warranty, and possibly the insurance, on the boat may become void.

### I-8 FLOTATION

If your boat is less than 20 ft. overall, a Coast Guard or BIA (Boating Industry of America), now changed to NMMA (National Marine Manufacturers Association), requirement is that the boat must have buoyant material built into the hull (usually foam) to keep it from sinking if it should become swamped. Coast Guard requirements are mandatory but the NMMA is voluntary.

"Kept from sinking" is defined as the ability of the flotation material to keep the boat from sinking when filled with water and with passengers clinging to the hull. One restriction is that the total weight of

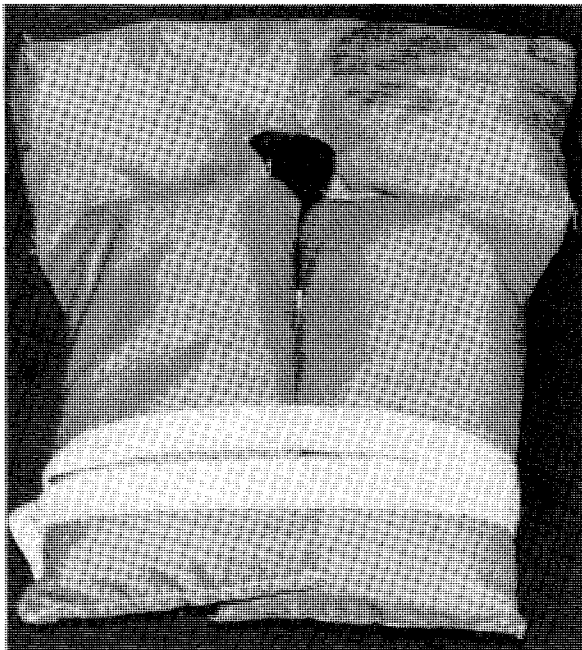

Type I PFD Coast Guard approved life jacket. This type flotation device provides the greatest amount of buoyancy. **NEVER** use them for cushions or other purposes.

the motor, passengers, and equipment aboard does not exceed the maximum load capacity listed on the plate.

### Life Preservers —Personal Flotation Devices (PFDs)

The Coast Guard requires at least one Coast Guard approved life-saving device be carried on board all motorboats for each person on board. Devices approved are identified by a tag indicating Coast Guard approval. Such devices may be life preservers, buoyant vests, ring buoys, or buoyant cushions. Cushions used for seating are serviceable if air cannot be squeezed out of it. Once air is released when the cushion is squeezed, it is no longer fit as a flotation device. New foam cushions dipped in a rubberized material are almost indestructible.

Life preservers have been classified by the Coast Guard into five type categories. All PFDs presently acceptable on recreational boats fall into one of these five designations. All PFDs **MUST** be U.S. Coast Guard approved, in good and serviceable condition, and of an appropriate size for the persons who intend to wear them. Wearable PFDs **MUST** be readily accessible and throwable devices **MUST** be immediately available for use.

**Type I PFD** has the greatest required buoyancy and is designed to turn most **UNCONSCIOUS** persons in the water from a face down position to a vertical or slightly



A Type IV PFD cushion device intended to be thrown to a person in the water. If air can be squeezed out of the cushion, it is no longer fit for service as a PFD.



backward position. The adult size device provides a minimum buoyancy of 22 pounds and the child size provides a minimum buoyancy of 11 pounds. The Type I PFD provides the greatest protection to its wearer and is most effective for all waters and conditions.

**Type II PFD** is designed to turn its wearer in a vertical or slightly backward position in the water. The turning action is not as pronounced as with a Type I. The device will not turn as many different type persons under the same conditions as the Type I. An adult size device provides a minimum buoyancy of 15½ pounds, the medium child size provides a minimum of 11 pounds, and the infant and small child sizes provide a minimum buoyancy of 7 pounds.

**Type III PFD** is designed to permit the wearer to place himself (herself) in a vertical or slightly backward position. The Type III device has the same buoyancy as the Type II PFD but it has little or no turning ability. Many of the Type III PFD are designed to be particularly useful when water skiing, sailing, hunting, fishing, or engaging in other water sports. Several of this type will also provide increased hypothermia protection.

**Type IV PFD** is designed to be thrown to a person in the water and grasped and held

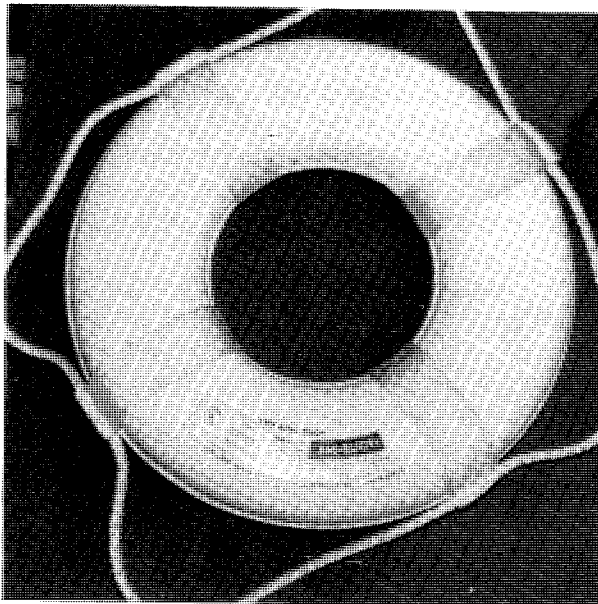

Type IV ring buoy also designed to be thrown to a person in the water. On ocean cruisers, this type device usually has a weighted pole with flag and light attached to the buoy.

by the user until rescued. It is **NOT** designed to be worn. The most common Type IV PFD is a ring buoy or a buoyant cushion.

**Type V PFD** is any PFD approved for restricted use.

Coast Guard regulations state, in general terms, that on all boats less than 16 ft. overall, one Type I, II, III, or IV device shall be carried on board for each person in the boat. On boats over 26 ft., one Type I, II, or III device shall be carried on board for each person in the boat **plus** one Type IV device.

It is an accepted fact that most boating people own life preservers, but too few actually wear them. There is little or no excuse for not wearing one because the modern comfortable designs available today do not subtract from an individual's boating pleasure. Make a life jacket available to your crew and advise each member to wear it. If you are a crew member ask your skipper to issue you one, especially when boating in rough weather, cold water, or when running at high speed. Naturally, a life jacket should be a must for non-swimmers any time they are out on the water in a boat.



Moisture-protected flares should be carried on board for use as a distress signal.

## 1-9 EMERGENCY EQUIPMENT

### Visual Distress Signals The Regulation

Since January 1, 1981, Coast Guard Regulations require all recreation boats when used on coastal waters, which includes the Great Lakes, the territorial seas and those waters directly connected to the Great Lakes and the territorial seas, up to a point where the waters are less than two miles wide, and boats owned in the United States, when operating on the high seas, to be equipped with visual distress signals.

The only exceptions are during daytime (sunrise to sunset) for:

Recreational boats less than 16 ft. (5 meters) in length.

Boats participating in organized events such as races, regattas or marine parades.

Open sailboats not equipped with propulsion machinery and less than 26 ft. (8 meters) in length.

Manually propelled boats.

The above listed boats need to carry night signals when used on these waters at night.

Pyrotechnic visual distress signaling devices **MUST** be Coast Guard Approved, in serviceable condition and stowed to be readily accessible. If they are marked with a

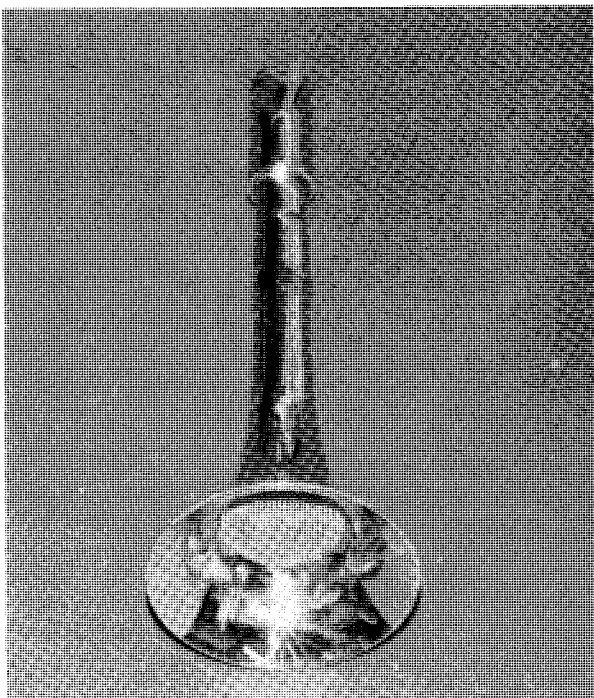

A sounding device should be mounted close to the helmsperson for use in sounding an emergency alarm.

date showing the serviceable life, this date must not have passed. Launchers, produced before Jan. 1, 1981, intended for use with approved signals are not required to be Coast Guard Approved.

USCG Approved pyrotechnic visual distress signals and associated devices include:

Pyrotechnic red flares, hand held or aerial.

Pyrotechnic orange smoke, hand held or floating.

Launchers for aerial red meteors or parachute flares.

Non-pyrotechnic visual distress signaling devices must carry the manufacturer's certification that they meet Coast Guard requirements. They must be in serviceable condition and stowed so as to be readily accessible.

This group includes:

Orange distress flag at least 3 x 3 feet with a black square and ball on an orange background.

Electric distress light -- not a flashlight but an approved electric distress light which **MUST** automatically flash the international **SOS** distress signal (. . . - - - . . .) four to six times each minute.

### Types and Quantities

The following variety and combination of devices may be carried in order to meet the requirements.

1- Three hand-held red flares (day and night).

2- One electric distress light (night only).

3- One hand-held red flare and two parachute flares (day and night).

4- One hand-held orange smoke signal, two floating orange smoke signals (day) and one electric distress light (day and night).

If young children are frequently aboard your boat, careful selection and proper stowage of visual distress signals becomes especially important. If you elect to carry pyrotechnic devices, you should select those in tough packaging and not easy to ignite should the devices fall into the hands of children.

Coast Guard Approved pyrotechnic devices carry an expiration date. This date can **NOT** exceed 42 months from the date of manufacture and at such time the device can no longer be counted toward the minimum requirements.

## SPECIAL WORDS

In some states the launchers for meteors and parachute flares may be considered a firearm. Therefore, check with your state authorities before acquiring such a launcher.

## First Aid Kits

The first-aid kit is similar to an insurance policy or life jacket. You hope you don't have to use it but if needed, you want it there. It is only natural to overlook this essential item because, let's face it, who likes to think of unpleasantness when planning to have only a good time. However, the prudent skipper is prepared ahead of time, and is thus able to handle the emergency without a lot of fuss.

Good commercial first-aid kits are available such as the Johnson and Johnson "Marine First-Aid Kit". With a very modest expenditure, a well-stocked and adequate kit can be prepared at home.

Any kit should include instruments, supplies, and a set of instructions for their use. Instruments should be protected in a watertight case and should include: scissors, tweezers, tourniquet, thermometer, safety pins, eye-washing cup, and a hot water bottle. The supplies in the kit should include: assorted bandages in addition to the various sizes of "band-aids", adhesive tape, absorbent cotton, applicators, petroleum jelly, antiseptic (liquid and ointment), local ointment, aspirin, eye ointment, antihistamine, ammonia inhalant, sea-sickness pills, antacid pills, and a laxative. You may want to consult your family physician about including antibiotics. Be sure your kit contains a first-aid manual because even though you have taken the Red Cross course, you may be the patient and have to rely on an untrained crew for care.



An adequately stocked first aid kit should be on board for the safety of crew and guests.

## Fire Extinguishers

All fire extinguishers must bear Underwriters Laboratory (UL) "Marine Type" approved labels. With the UL certification, the extinguisher does not have to have a Coast Guard approval number. The Coast Guard classifies fire extinguishers according to their size and type.

**Type B-I or B-II** Designed for extinguishing flammable liquids. Required on all motorboats.

The Coast Guard considers a boat having one or more of the following conditions as a "boat of closed construction" subject to fire extinguisher regulations.

- 1- Inboard engine or engines.
- 2- Closed compartments under thwarts and seats wherein portable fuel tanks may be stored.
- 3- Double bottoms not sealed to the hull or which are not completely filled with flotation materials.
- 4- Closed living spaces.
- 5- Closed stowage compartments in which combustible or flammable material is stored.
- 6- Permanently installed fuel tanks.

Detailed classification of fire extinguishers is by agent and size:



A suitable fire extinguisher should be mounted close to the helmsperson for emergency use.

## 1-14 SAFETY

**B-I** contains 1-1/4 gallons foam, 4 pounds carbon dioxide, 2 pounds dry chemical, and 2-1/2 pounds freon.

**B-II** contains 2-1/2 gallons foam, 15 pounds carbon dioxide, and 10 pounds dry chemical.

The class of motorboat dictates how many fire extinguishers are required on board. One B-II unit can be substituted for two B-I extinguishers.

Dry chemical fire extinguishers without gauges or indicating devices must be weighed and tagged every 6 months. If the gross weight of a carbon dioxide (CO<sub>2</sub>) fire extinguisher is reduced by more than 10% of the net weight, the extinguisher is not acceptable and must be recharged.

**READ** labels on fire extinguishers. If the extinguisher is U.L. listed, it is approved for marine use.

**DOUBLE** the number of fire extinguishers recommended by the Coast Guard, because their requirements are a bare **MINIMUM** for safe operation. Your boat, family, and crew, must certainly be worth much more than "bare minimum".

## 1-10 COMPASS

### Selection

The safety of the boat and her crew may depend on her compass. In many areas weather conditions can change so rapidly that within minutes a skipper may find himself "socked-in" by a fog bank, a rain squall, or just poor visibility. Under these conditions, he may have no other means of keep-

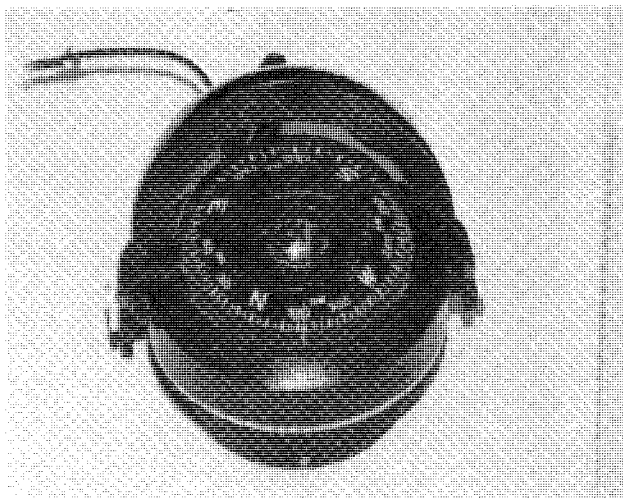

*Do not hesitate to spend a few extra dollars for a good, reliable compass. If in doubt, seek advice from fellow boaters.*

ing to his desired course except with the compass. When crossing an open body of water, his compass may be the only means of making an accurate landfall.

During thick weather when you can neither see nor hear the expected aids to navigation, attempting to run out the time on a given course can disrupt the pleasure of the cruise. The skipper gains little comfort in a chain of soundings that does not match those given on the chart for the expected area. Any stranding, even for a short time, can be an unnerving experience.

A pilot will not knowingly accept a cheap parachute. A good boater should not accept a bargain in lifejackets, fire extinguishers, or compass. Take the time and spend the few extra dollars to purchase a compass to fit your expected needs. Regardless of what the salesman may tell you, postpone buying until you have had the chance to check more than one make and model.

Lift each compass, tilt and turn it, simulating expected motions of the boat. The compass card should have a smooth and stable reaction.

The card of a good quality compass will come to rest without oscillations about the lubber's line. Reasonable movement in your hand, comparable to the rolling and pitching of the boat, should not materially affect the reading.

### Installation

Proper installation of the compass does not happen by accident. Make a critical check of the proposed location to be sure compass placement will permit the helmsman to use it with comfort and accuracy. First, the compass should be placed directly in front of the helmsman and in such a position that it can be viewed without body stress as he sits or stands in a posture of relaxed alertness. The compass should be in the helmsman's zone of comfort. If the compass is too far away, he may have to bend forward to watch it; too close and he must rear backward for relief.

Second, give some thought to comfort in heavy weather and poor visibility conditions during the day and night. In some cases, the compass position may be partially determined by the location of the wheel, shift lever, and throttle handle.

Third, inspect the compass site to be sure the instrument will be at least two feet

from any engine indicators, bilge vapor detectors, magnetic instruments, or any steel or iron objects. If the compass cannot be placed at least two feet (six feet would be better) from one of these influences, then either the compass or the other object must be moved, if first order accuracy is to be expected.

Once the compass location appears to be satisfactory, give the compass a test before installation. Hidden influences may be concealed under the cabin top, forward of the cabin aft bulkhead, within the cockpit ceiling, or in a wood-covered stanchion.

Move the compass around in the area of the proposed location. Keep an eye on the card. A magnetic influence is the only thing that will make the card turn. You can quickly find any such influence with the compass. If the influence can not be moved away or replaced by one of non-magnetic material, test to determine whether it is merely magnetic, a small piece of iron or steel, or some magnetized steel. Bring the north pole of the compass near the object, then shift and bring the south pole near it. Both the north and south poles will be attracted if the compass is demagnetized. If the object attracts one pole and repels the other, then the compass is magnetized. If your compass needs to be demagnetized, take it to a shop equipped to do the job **PROPERLY**.

After you have moved the compass around in the proposed mounting area, hold it down or tape it in position. Test everything you feel might affect the compass and cause a deviation from a true reading. Rotate the wheel from hard over to hard over. Switch on and off all the lights, radios, radio direction finder, radio telephone, depth finder and the shipboard intercom, if one is installed. Sound the electric whistle, turn on the windshield wipers, start the engine (with water circulating through the engine), work the throttle, and move the gear shift lever. If the boat has an auxiliary generator, start it.

If the card moves during any one of these tests, the compass should be relocated. Naturally, if something like the windshield wipers causes a slight deviation, it may be necessary for you to make a different deviation table to use only when certain pieces of equipment are operating. Bear in mind, following a course that is only off a degree or two for several hours can make

considerable difference at the end, putting you on a reef, rock, or shoal.

Check to be sure the intended compass site is solid. Vibration will increase pivot wear.

Now, you are ready to mount the compass. To prevent an error on all courses, the line through the lubber line and the compass card pivot must be exactly parallel to the keel of the boat. You can establish the fore-and-aft line of the boat with a stout cord or string. Use care to transfer this line to the compass site. If necessary, shim the base of the compass until the stile-type lubber line (the one affixed to the case and not gimbaled) is vertical when the boat is on an even keel. Drill the holes and mount the compass.

### Magnetic Items After Installation

Many times an owner will install an expensive stereo system in the cabin of his boat. It is not uncommon for the speakers to be mounted on the aft bulkhead up against the overhead (ceiling). In almost every case, this position places one of the speakers in very close proximity to the compass, mounted above the ceiling.

As we all know, a magnet is used in the operation of the speaker. Therefore, it is very likely that the speaker, mounted almost under the compass in the cabin will have a very pronounced affect on the compass accuracy.

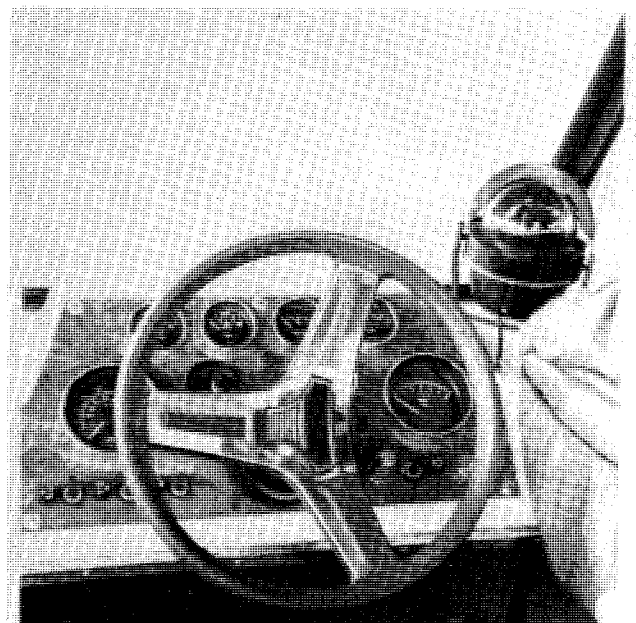

*The compass is a delicate instrument and deserves respect. It should be mounted securely and in position where it can be easily observed by the helmsperson.*

## 1-16 SAFETY

Consider the following test and the accompanying photographs as prove of the statements made.

First, the compass was read as 190 degrees while the boat was secure in her slip.

Next a full can of diet coke in an **aluminum** can was placed on one side and the compass read as 204 degrees, a good 14 degrees off.

Next, the full can was moved to the opposite side of the compass and again a reading was observed. This time as 189



*"Innocent" objects close to the compass, such as diet coke in an aluminum can, may cause serious problems and lead to disaster, as these three photos and the accompanying text prove.*

degrees, 11 degrees off from the original reading.

Finally the contents of the can were consumed, the can placed on both sides of the compass with **NO** affect on the compass reading.

Two very important conclusions can be drawn from these tests.

1- Something must have been in the contents of the can to affect the compass so drastically.

2- Keep even "innocent" things clear of the compass to avoid any possible error in the boat's heading.

**REMEMBER**, a boat moving through the water at 10 knots on a compass error of just 5 degrees will be almost 1.5 miles off course in only **ONE** hour. At night, or in thick weather, this could very possibly put the boat on a reef, rock, or shoal, with disastrous results.

## 1-11 ANCHORS

One of the most important pieces of equipment in the boat next to the power plant is the ground tackle carried. The engine makes the boat go and the anchor and its line are what hold it in place when the boat is not secured to a dock or on the beach.

The anchor must be of suitable size, type, and weight to give the skipper peace of mind when his boat is at anchor. Under certain conditions, a second, smaller, lighter anchor may help to keep the boat in a favorable position during a non-emergency daytime situation.

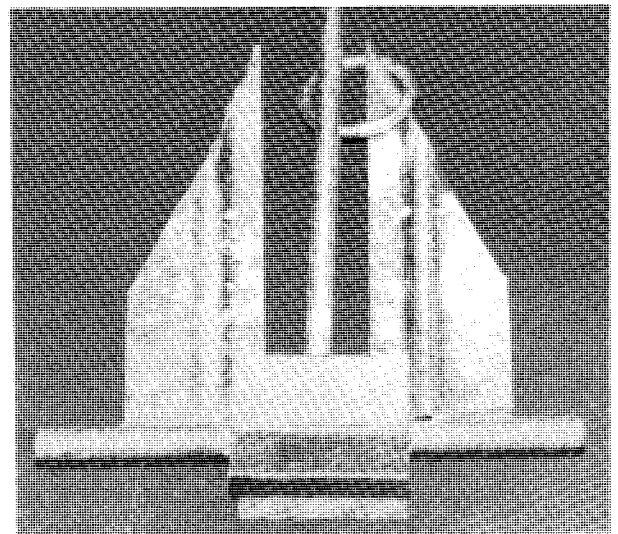

*The weight of the anchor **MUST** be adequate to secure the boat without dragging.*



In order for the anchor to hold properly, a piece of chain must be attached to the anchor and then the nylon anchor line attached to the chain. The amount of chain should equal or exceed the length of the boat. Such a piece of chain will ensure that the anchor stock will lay in an approximate horizontal position and permit the flutes to dig into the bottom and hold.

## 1-12 MISCELLANEOUS EQUIPMENT

In addition to the equipment you are legally required to carry in the boat and those previously mentioned, some extra items will add to your boating pleasure and safety. Practical suggestions would include: a bailing device (bucket, pump, etc.), boat hook, fenders, spare propeller, spare engine parts, tools, an auxiliary means of propulsion (paddle or oars), spare can of gasoline, flashlight, and extra warm clothing. The area of your boating activity, weather conditions, length of stay aboard your boat, and the specific purpose will all contribute to the kind and amount of stores you put aboard. When it comes to personal gear, heed the advice of veteran boaters who say, "Decide on how little you think you can get by with, then cut it in half".

### Bilge Pumps

Automatic bilge pumps should be equipped with an overriding manual switch. They should also have an indicator in the operator's position to advise the helmsman when the pump is operating. Select a pump that will stabilize its temperature within the manufacturer's specified limits when it is operated continuously. The pump motor should be a sealed or arcless type, suitable for a marine atmosphere. Place the bilge pump inlets so excess bilge water can be removed at all normal boat trims. The intakes should be properly screened to prevent the pump from sucking up debris from the bilge. Intake tubing should be of a high quality and stiff enough to resist kinking and not collapse under maximum pump suction condition if the intake becomes blocked.

To test operation of the bilge pump, operate the pump switch. If the motor does not run, disconnect the leads to the motor. Connect a voltmeter to the leads and see if voltage is indicated. If voltage is not indicated, then the problem must be in a blown

fuse, defective switch, or some other area of the electrical system.

If the meter indicates voltage is present at the leads, then remove, disassemble, and inspect the bilge pump. Clean it, reassemble, connect the leads, and operate the switch again. If the motor still fails to run, the pump must be replaced.

To test the bilge pump switch, first disconnect the leads from the pump and connect them to a test light.

Next, hold the switch firmly against the mounting location in order to make a good ground. Now, tilt the opposite end of the switch upward until it is activated as indicated by the test light coming on or the ohmmeter showing continuity. Finally, lower the switch slowly toward the mounting position until it is deactivated. Measure the distance between the point the switch was activated and the point it was deactivated. For proper service, the switch should deactivate between 1/2-inch and 1/4-inch from the planned mounting position. **CAUTION:** The switch must never be mounted lower than the bilge pump pickup.

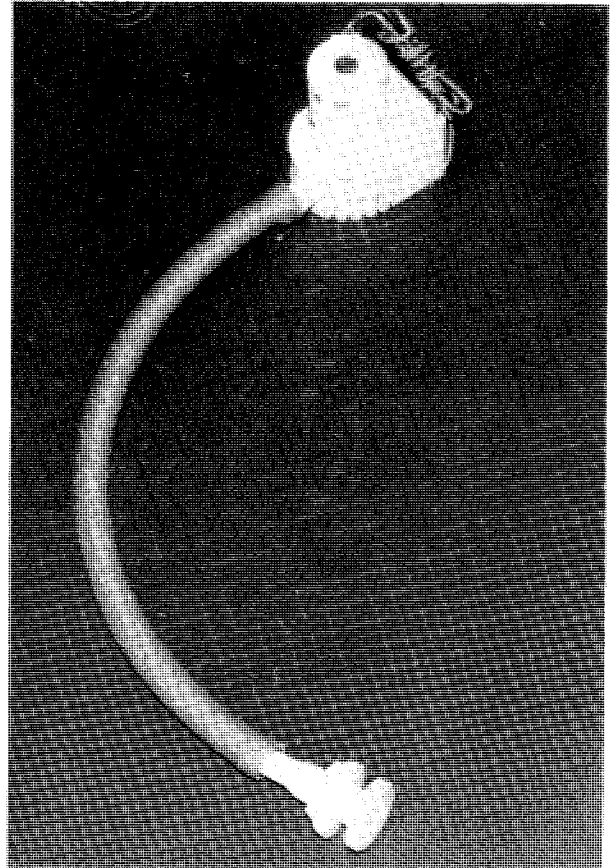

*The bilge pump line must be cleaned frequently to ensure the bilge pump will be able to do its job in an emergency.*

### I-13 BOATING ACCIDENT REPORTS

New federal and state regulations require an accident report to be filed with the nearest State boating authority within 48 hours if a person is lost, disappears, or is injured to the degree of needing medical treatment beyond first aid.

Accidents involving only property or equipment damage **MUST** be reported within 10 days if the damage is in excess of \$200. Some states require reporting of accidents with property damage less than \$200 or total boat loss.

A **\$500 PENALTY** may be assessed for failure to submit the report.

#### WORD OF ADVICE

Take time to make a copy of the report to keep for your records or for the insurance company. Once the report is filed, the Coast Guard will not give out a copy, even to the person who filed the report.

The report must give details of the accident and include:

- 1- The date, time, and exact location of the occurrence.
- 2- The name of each person who died, was lost, or injured.
- 3- The number and name of the vessel.
- 4- The names and addresses of the owner and operator.

If the operator cannot file the report for any reason, each person on board **MUST** notify the authorities, or determine that the report has been filed.

### I-14 NAVIGATION

#### Buoys

In the United States, a buoyage system is used as an assist to all boaters of all size craft to navigate our coastal waters and our navigable rivers in safety. When properly read and understood, these buoys and markers will permit the boater to cruise with comparative confidence that he will be able to avoid reefs, rocks, shoals, and other hazards.

In the spring of 1983, the Coast Guard began making modifications to U.S. aids to navigation in support of an agreement sponsored by the International Association of Lighthouse Authorities (IALA) and signed by representatives from most of the maritime nations of the world. The primary purpose of the modifications is to improve safety by

making buoyage systems around the world more alike and less confusing.

#### Lights

The following information regarding lights required on boats between sunset and sunrise or during restricted visibility is taken directly from a U.S. Coast Guard publication dated 1984.

The terms **"PORT"** and **"STARBOARD"** are used to refer to the left and right side of the boat, when looking forward. One easy way to remember this basic fundamental is to consider the words "port" and "left" both have four letters and go together.

#### Waterway Rules

On the water, certain basic safe-operating practices must be followed. You should learn and practice them, for to **know**, is to be able to handle your boat with confidence and safety. Knowledge of what to do, and not do, will add a great deal to the enjoyment you will receive from your boating investment.

#### Rules of the Road

The best advice possible and a Coast Guard requirement for boats over 39' 4" (12 meters) since 1981, is to obtain an official copy of the "Rules of the Road", which includes Inland Waterways, Western Rivers, and the Great Lakes for study and ready reference.

The following two paragraphs give a **VERY** brief, condensed, and abbreviated -- synopsis of the rules. They should not be considered in any way as covering the entire subject.

Powered boats must yield the right-of-way to all boats without motors, except when being overtaken. When meeting another boat head-on, keep to starboard, unless you are too far to port to make this practical. When overtaking another boat, the right-of-way belongs to the boat being overtaken. If your boat is being passed, you must maintain course and speed.

When two boats approach at an angle and there is danger of collision, the boat to port must give way to the boat to starboard. Always keep to starboard in a narrow channel or canal. Boats underway must stay clear of vessels fishing with nets, lines, or trawls. (Fishing boats are not allowed to fish in channels or to obstruct navigation.)



# 2

## TUNING

### 2-1 INTRODUCTION

The efficiency, reliability, fuel economy and enjoyment available from engine performance are all directly dependent on having it tuned properly. The importance of performing service work in the sequence detailed in this chapter cannot be over emphasized. Before making any adjustments, check the specifications in the Appendix. **NEVER** rely on memory when making critical adjustments.

Before beginning to tune any engine, check to be sure the engine has satisfactory compression. An engine with worn or broken piston rings, burned pistons, or scored cylinder walls, cannot be made to perform properly no matter how much time and expense is spent on the tune-up. Poor compression must be corrected or the tune-up will not give the desired results.

A practical maintenance program that is followed throughout the year, is one of the

best methods of ensuring the engine will give satisfactory performance at any time.

The extent of the engine tune-up is usually dependent on the time lapse since the last service. A complete tune-up of the entire engine would entail almost all of the work outlined in this manual. A logical sequence of steps will be presented in general terms. If additional information or

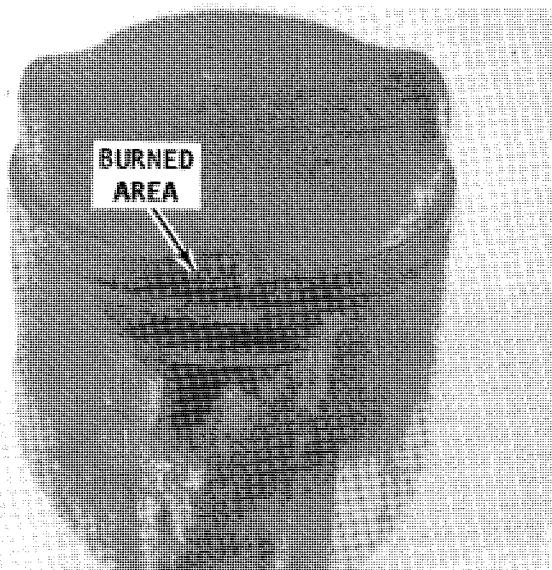

Damaged piston, probably caused by inaccurate fuel mixture, or improper timing.

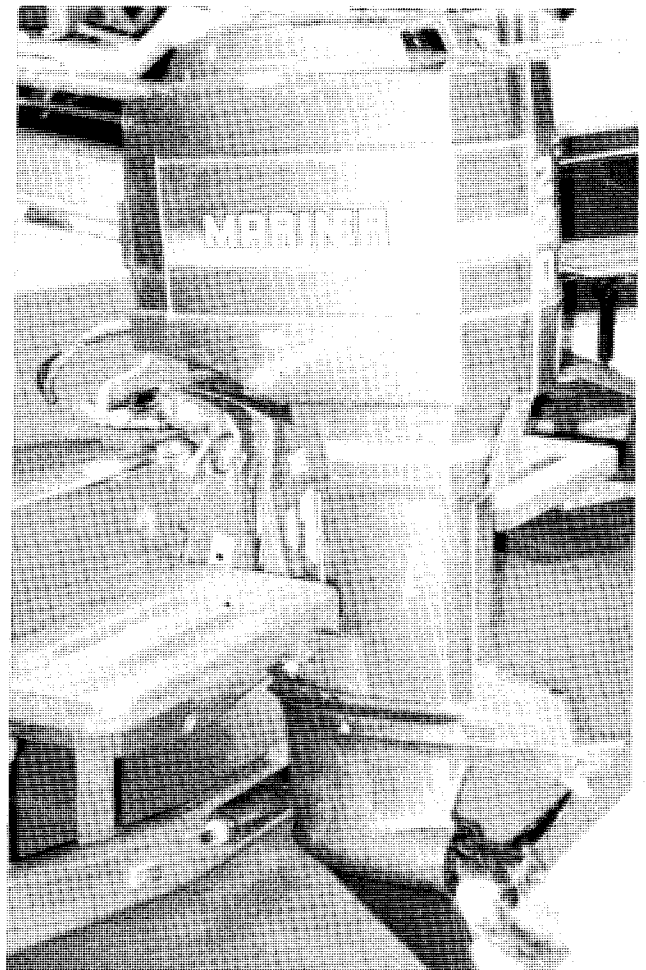

A clean exterior engine appearance reflects this owner's pride in his unit. Keeping the interior well-lubricated and properly tuned will give him/her the enjoyment deserved for the investment.

## 2-2 TUNING

detailed service work is required, the chapter containing the instructions will be referenced.

Each year higher compression ratios are built into modern outboard engines and the electrical systems become more complex, especially with electronic (capacitor discharge) units. Therefore, the need for reliable, authoritative, and detailed instructions becomes more critical. The information in this chapter and the referenced chapters fulfill that requirement.

### 2-2 TUNE-UP SEQUENCE

During a major tune-up, a definite sequence of service work should be followed to return the engine to the maximum performance desired. This type of work should not be confused with attempting to locate problem areas of "why" the engine is not performing satisfactorily. This work is classified as "trouble shooting". In many cases, these two areas will overlap, because many times a minor or major tune-up will correct the malfunction and return the system to normal operation.

The following list is a suggested sequence of tasks to perform during the tune-up service work. The tasks are merely listed here. Generally procedures are given in subsequent sections of this chapter. For more detailed instructions, see the referenced chapter.

1- Perform a compression check of each cylinder. See Chapter 6.

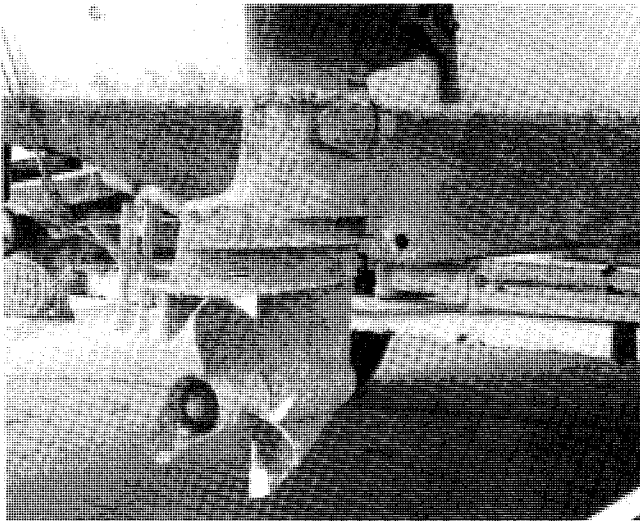

*A boat and lower unit covered with marine growth. Such a condition is a serious hinderance to performance and cannot be corrected by tuning the powerhead.*

2- Inspect the spark plugs to determine their condition. Test for adequate spark at the plug. See Chapter 6.

3- Start the engine in a body of water and check the water flow through the powerhead, See Chapter 11.

4- Check the gear oil in the lower unit. See Chapter 11.

5- Check the carburetor adjustments and the need for an overhaul. See Chapter 4.

6- Check the fuel pump for adequate performance and delivery. See Chapter 4.

7- Make a general inspection of the ignition system. See Chapter 6.

8- Test the cranking motor and the solenoid. See Chapter 9.

9- Check the internal wiring.

10- Check the timing and synchronization. See Chapter 7.

### 2-3 COMPRESSION CHECK

A compression check is extremely important, because an engine with low or uneven compression between cylinders **CAN-**

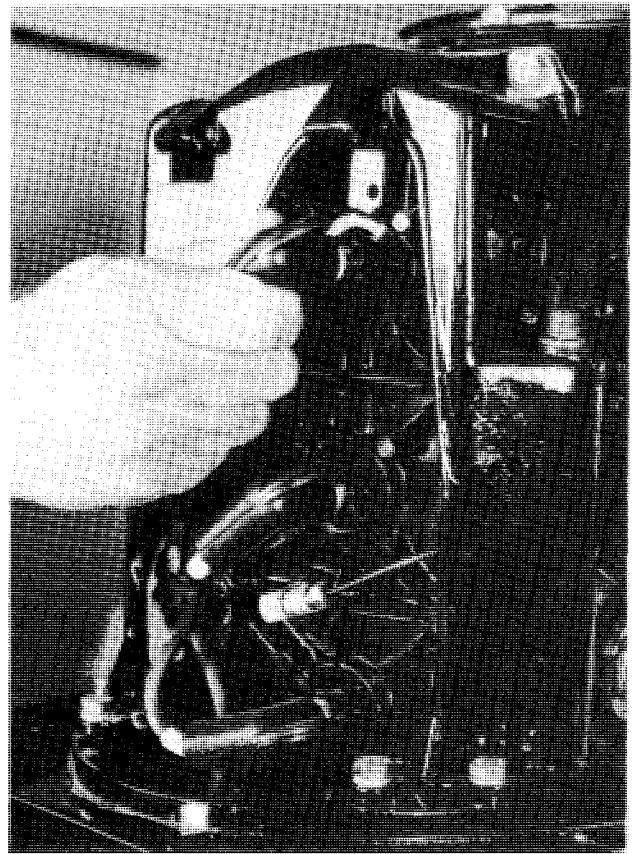

*Removing the spark plugs for inspection. Worn plugs are one of the major contributing factors to poor engine performance.*

**NOT** be tuned to operate satisfactorily. Therefore, it is essential that any compression problem be corrected before proceeding with the tune-up procedure. See Chapter 8.

If the powerhead shows any indication of overheating, such as discolored or scorched paint, inspect the cylinders visually thru the transfer ports for possible scoring. It is possible for a cylinder with satisfactory compression to be scored slightly. Also, check the water pump. The overheating condition may be caused by a faulty water pump.

### Checking Compression

Remove the spark plug wires. **ALWAYS** grasp the molded cap and pull it loose with a twisting motion to prevent damage to the connection. Remove the spark plugs and keep them in **ORDER** by cylinder for evaluation later. Ground the spark plug leads to the engine to render the ignition system inoperative while performing the compression check.

Insert a compression gauge into the No. 1, top, spark plug opening. Crank the

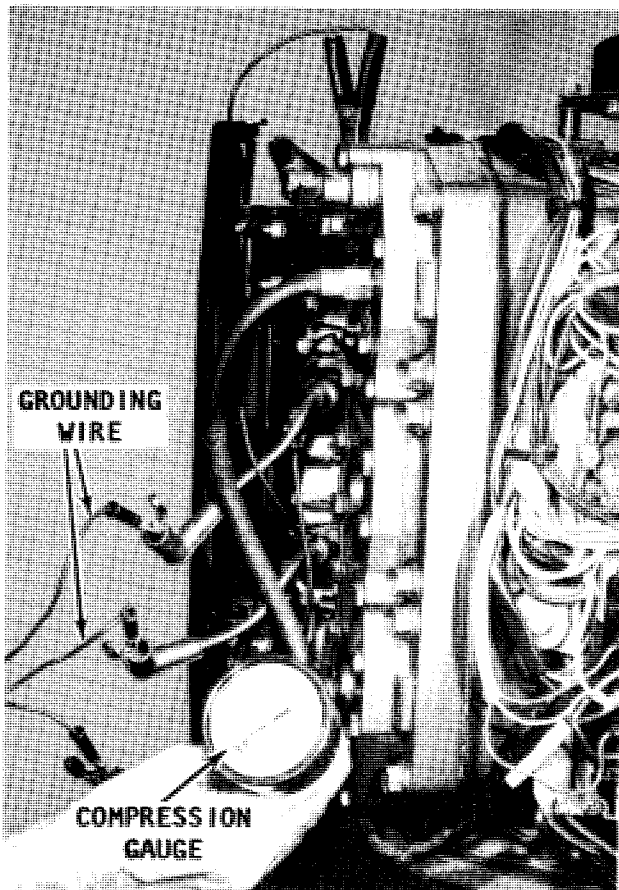

All spark plugs should be "grounded" while making compression tests. This action will prevent placing an extra load on the ignition coil.

powerhead, with the cranking motor, thru at least 4 complete revolutions of the crankshaft, with the throttle at the wide-open position, to obtain the highest possible reading. Record the highest reading. Repeat the test and record the compression for each cylinder. A variation between cylinders is far more important than the actual readings. A variation of more than 15 psi between cylinders indicates the lower compression cylinder is defective. The problem may be worn, broken, or sticking piston rings, scored pistons or worn cylinders.

Use of an engine cleaner will help to free stuck rings and to dissolve accumulated carbon. Follow the directions on the can.

### 2-4 SPARK PLUG INSPECTION

All spark plugs installed on powerheads covered in this manual are of the non-adjustable surface gap type, as shown in the accompanying illustration.

The spark plugs should be replaced if the center electrode has burned back more than 1/32" (0.8mm) below the spark plug surface.

Inspect each spark plug for badly worn electrodes, glazed, broken, blistered, or lead fouled insulators. Replace all plugs, if one shows signs of excessive wear.

Make an evaluation of the cylinder performance by comparing the spark condition with those shown in Chapter 6. Check each spark plug to be sure they are all of the same manufacturer, and have the same heat range rating.

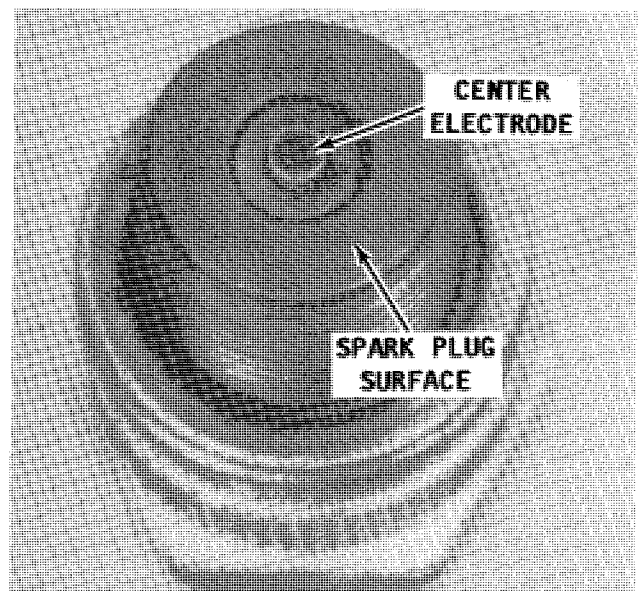

Example of a non-adjustable surface gap spark plug operated under favorable conditions.

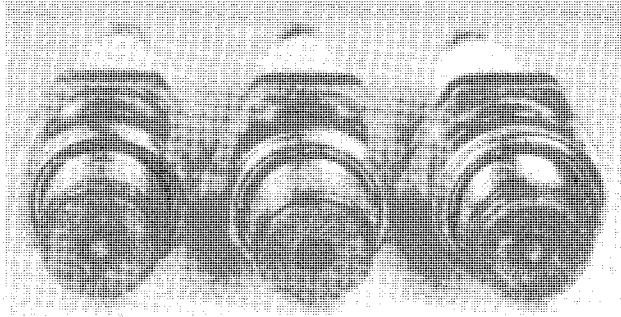

After removal, the spark plugs should be kept in order to permit a proper diagnosis to be made of how each cylinder has been operating.

Inspect the threads in the spark plug opening of the block, and clean the threads before installing the plug.

When purchasing new spark plugs, **ALWAYS** ask the marine dealer if there has been a spark plug change for the engine being serviced.

Crank the powerhead through several revolutions to blow out any material which might have become dislodged during cleaning.

Install the spark plugs and tighten them to a torque value of 20ft lbs (26Nm). **ALWAYS** use a new gasket and wipe the seats in the block clean. The gasket must be fully compressed on clean seats to complete the heat transfer process and to provide a gas tight seal in the cylinder. If the torque value is too high, the heat will dissipate too rapidly. Conversely, if the torque value is too low, heat will not dissipate fast enough.

## 2-5 IGNITION SYSTEM

Two different ignition systems are used on the powerheads covered in this manual. Each system is easily recognized. One system has a distributor. Only a few early 90, 115, and 140hp 6-cylinder in-line powerheads have the distributor ignition.

Instead of a distributor, the new ignition system is labeled, Thunderbolt Flywheel CD Ignition. Almost all the powerheads covered in this manual have the new distributorless ignition system. The majority of ignition components for this new ignition system are housed under the flywheel.

The Thunderbolt Flywheel C.D. system has an ignition coil for each cylinder. The Thunderbolt Pointless Distributor C.D. system has only one coil which serves all cylinders. If powerhead performance is less than expected, and the ignition is diagnosed

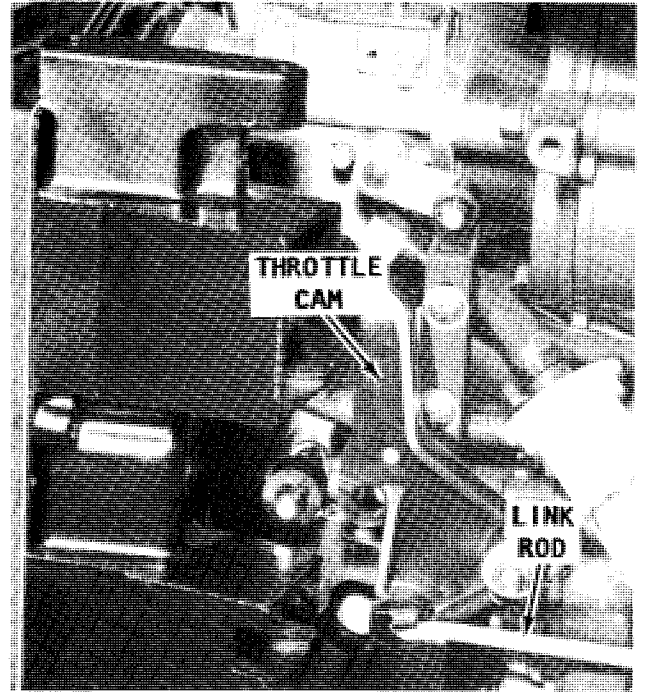

The fuel and ignition systems on any powerhead **MUST** be properly synchronized before maximum performance can be obtained from the unit.

as the problem area, refer to Chapter 6 for detailed service procedures.

To properly time and synchronize the ignition system with the fuel system, see Chapter 7.

## 2-6 TIMING AND SYNCHRONIZING

Correct timing and synchronization are essential to efficient engine operation. An engine may be in apparent excellent mechanical condition, but perform poorly, unless the timing and synchronization have been adjusted precisely, according to the Specifications in the Appendix. To time and synchronize the engine, see Chapter 7.

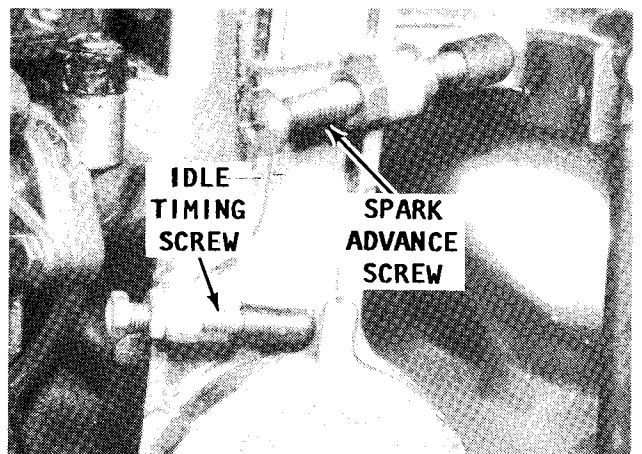

Typical location for some of the major adjustment points to synchronize and time a V6 powerhead.



**Download the full PDF manual instantly.**

**Our customer service e-mail:**

**[aservicemanualpdf@yahoo.com](mailto:aservicemanualpdf@yahoo.com)**