

**PY50837**

KEY	PART NO.	PART NAME	QTY	Engine Serial No.	5310	5610	REMARKS
1	R56463	O-RING	1		X	X	21.819 X 3.531 mm
2	R92154	ELBOW FITTING	1		X	X	
3	AT18904	CLAMP	2		X	X	
4	R99793	HOSE	1	____-113592	X		
5	R519549	VENT	1		X	X	(FROM SR.NO. 5310 (113593- ), 5610 (000001- ))
6	RE522889	VENT	1		X	X	(FROM SR.NO. 5310 (113593- ), 5610 (000001- ))
7	19H1255	CAP SCREW	1		X	X	(FROM SR.NO. 5310 (113593- ), 5610 (000001- )) 3/8" X 5/8"
8	T30726	WASHER	1		X	X	(FROM SR.NO. 5310 (113593- ), 5610 (000001- ))

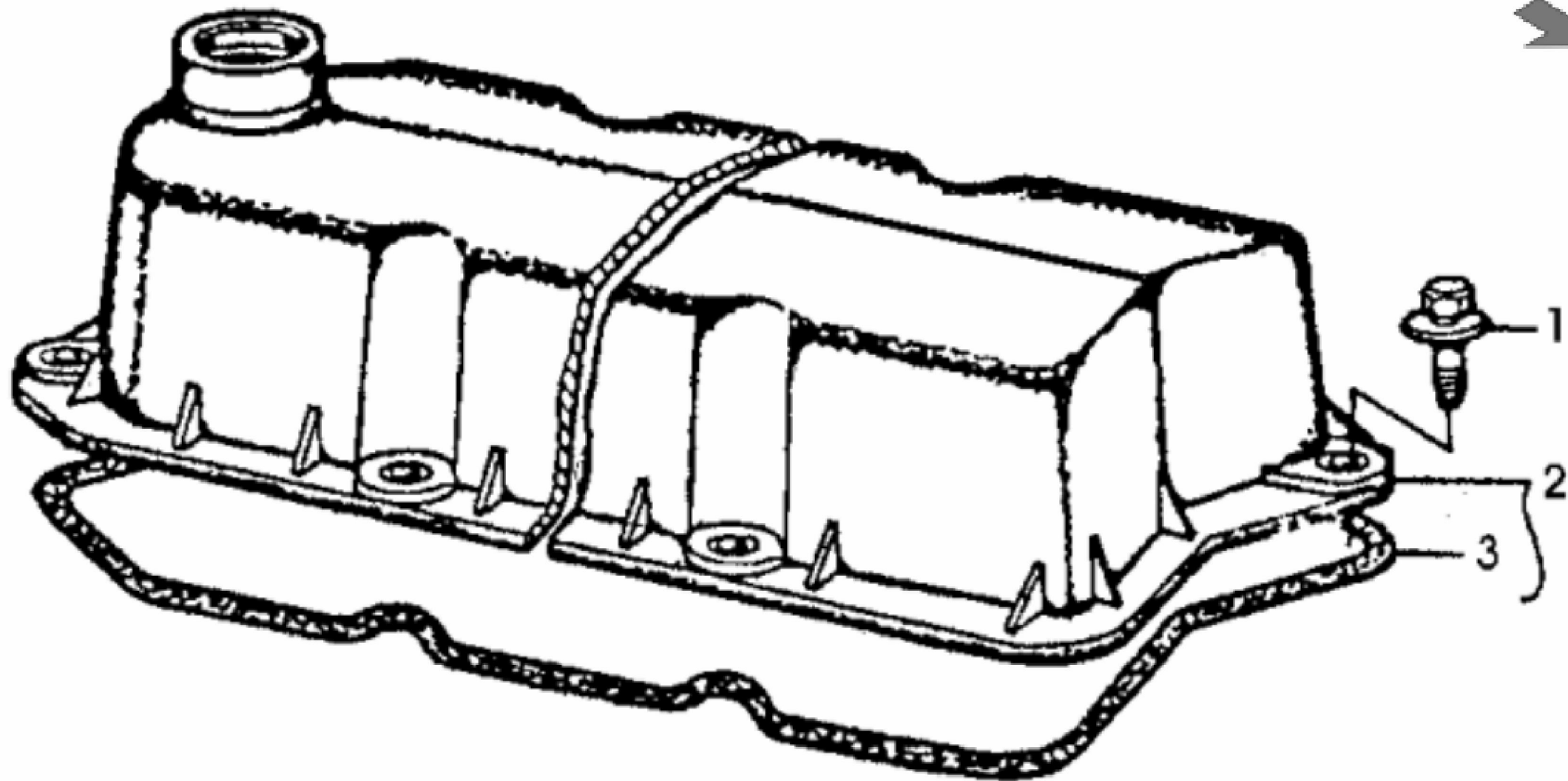

PY50072

KEY	PART NO.	PART NAME	QTY	5310	5610	REMARKS	
1	RE32140	SCREW WITH WASHER	6	X	X		
2	RE515827	VALVE COVER	1	X	X	(For India Market Only)	
2	RE527538	COVER	1	X	X		
3	R106796	O-RING	1	X	X	(For India Market Only) USE WITH RE515827	
3	R75729	GASKET	1	X	X	USE WITH RE527538	

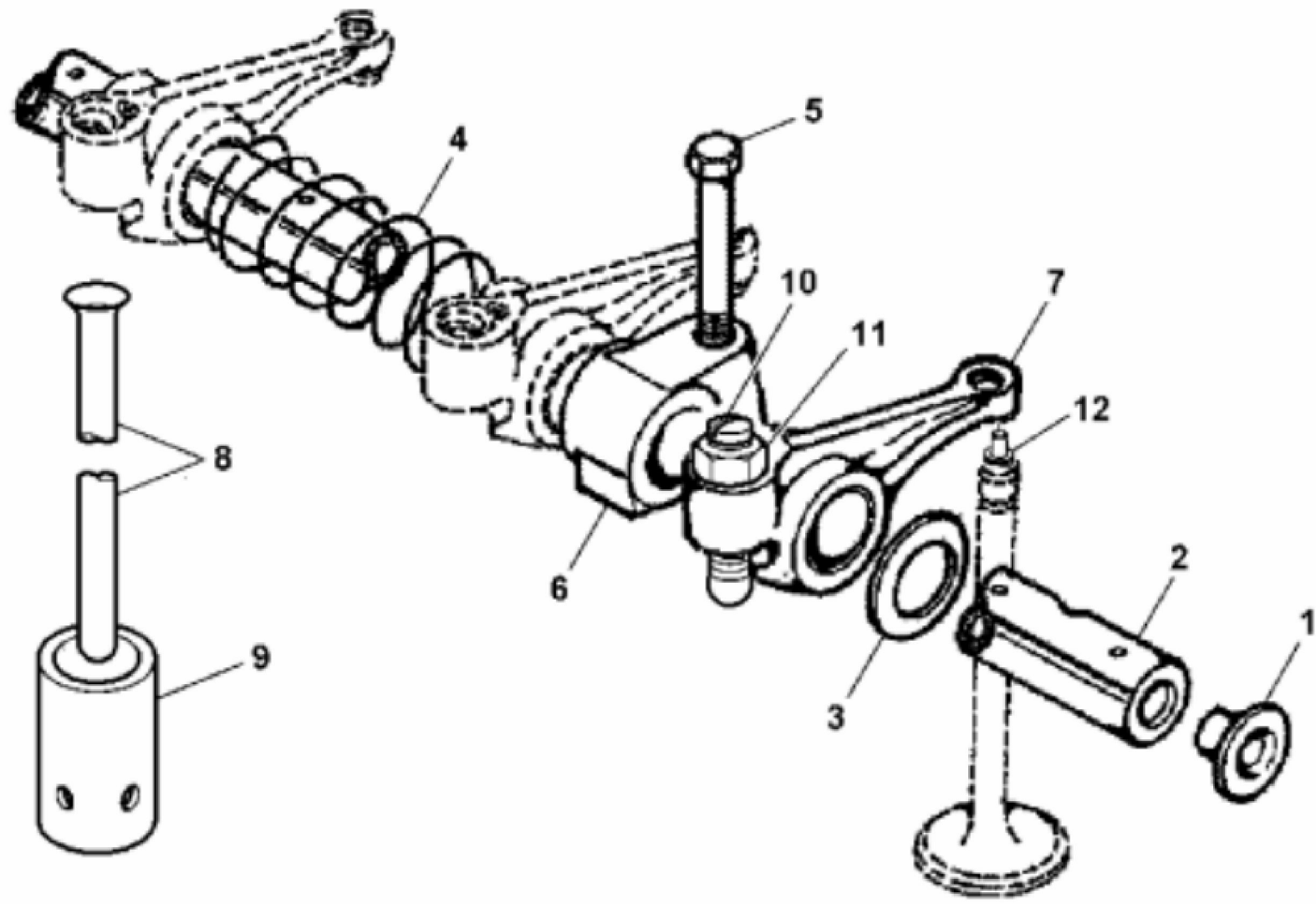

PY52171

KEY	PART NO.	PART NAME	QTY	5310	5610	REMARKS	
1	R54565	PLUG	2	X	X		
2	.....	SHAFT	1	X	X	NLA; ORDER RE519735	
2	RE519735	ROCKER ARM SHAFT	1	X	X	SUB FOR R501532	
3	T20316	WASHER	2	X	X		
4	T20314	SPRING	2	X	X		
5	R504813	SELF-LOCKING SCREW	3	X	X	(SAE 8)	
6	R123161	SUPPORT	3	X	X	(SUB FOR R516741)	
7	RE62148	ROCKER ARM	6	X	X		
8	R515095	PUSH ROD	6	X	X		
9	R515092	TAPPET	6	X	X	LGTH=234MM (9.21")	
10	R515577	SCREW	6	X	X		
11	R125881	LOCK NUT	6	X	X		
12	T26872	INSERT	6	X	X		

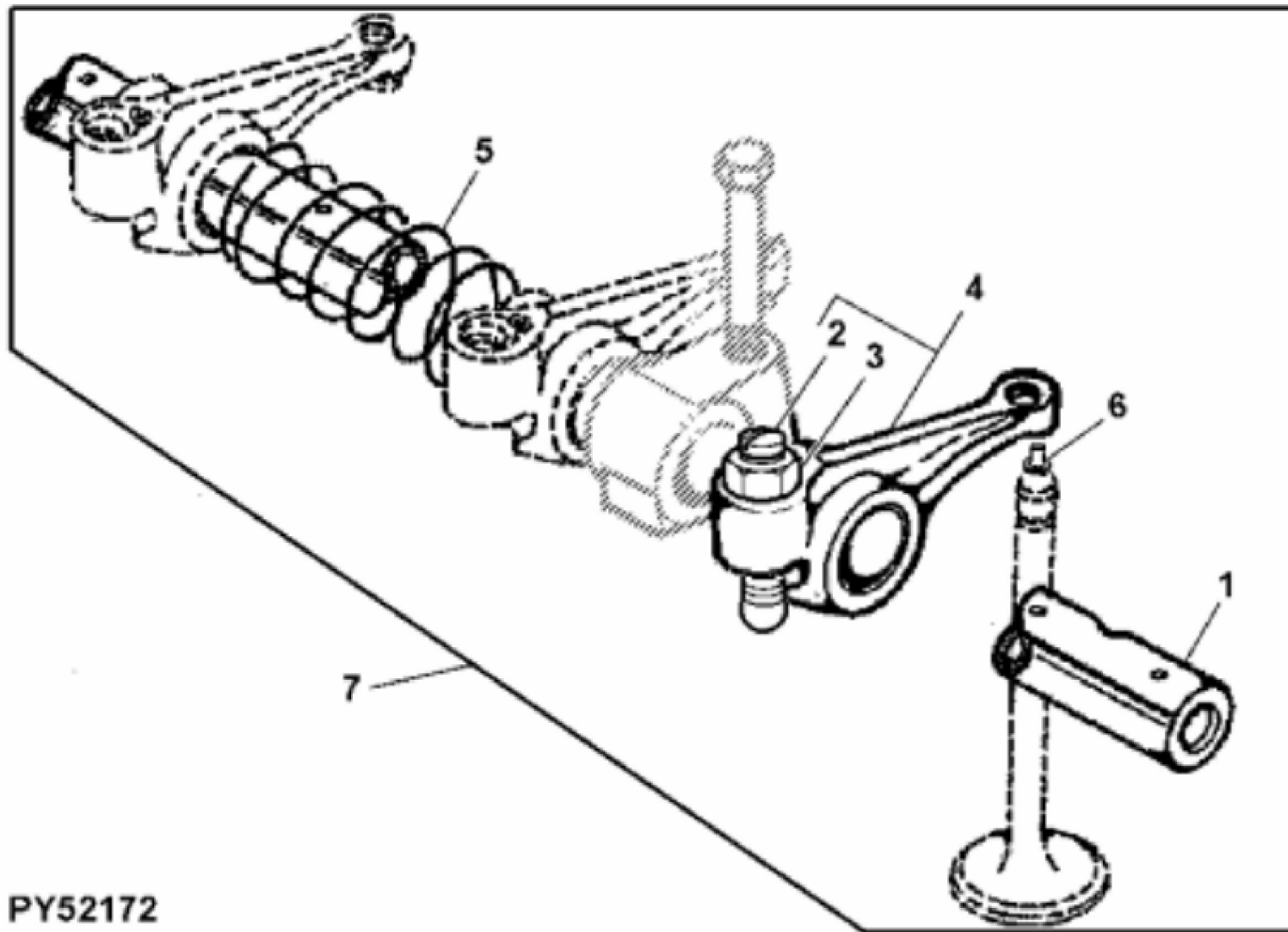

PY52172

KEY	PART NO.	PART NAME	QTY	5310	5610	REMARKS	
1	.....	SHAFT	1	X	X	NLA; ORDER RE519735	
1	RE519735	ROCKER ARM SHAFT	1	X	X	SUB FOR R501532	
2	R515577	SCREW	6	X	X		
3	R125881	LOCK NUT	6	X	X		
4	RE62148	ROCKER ARM	6	X	X		
5	T20314	SPRING	2	X	X		
6	T26872	INSERT	6	X	X		
7	RE515459	ROCKER ARM SHAFT	1	X	X	ASSY (INCL KEYS 1-6)	



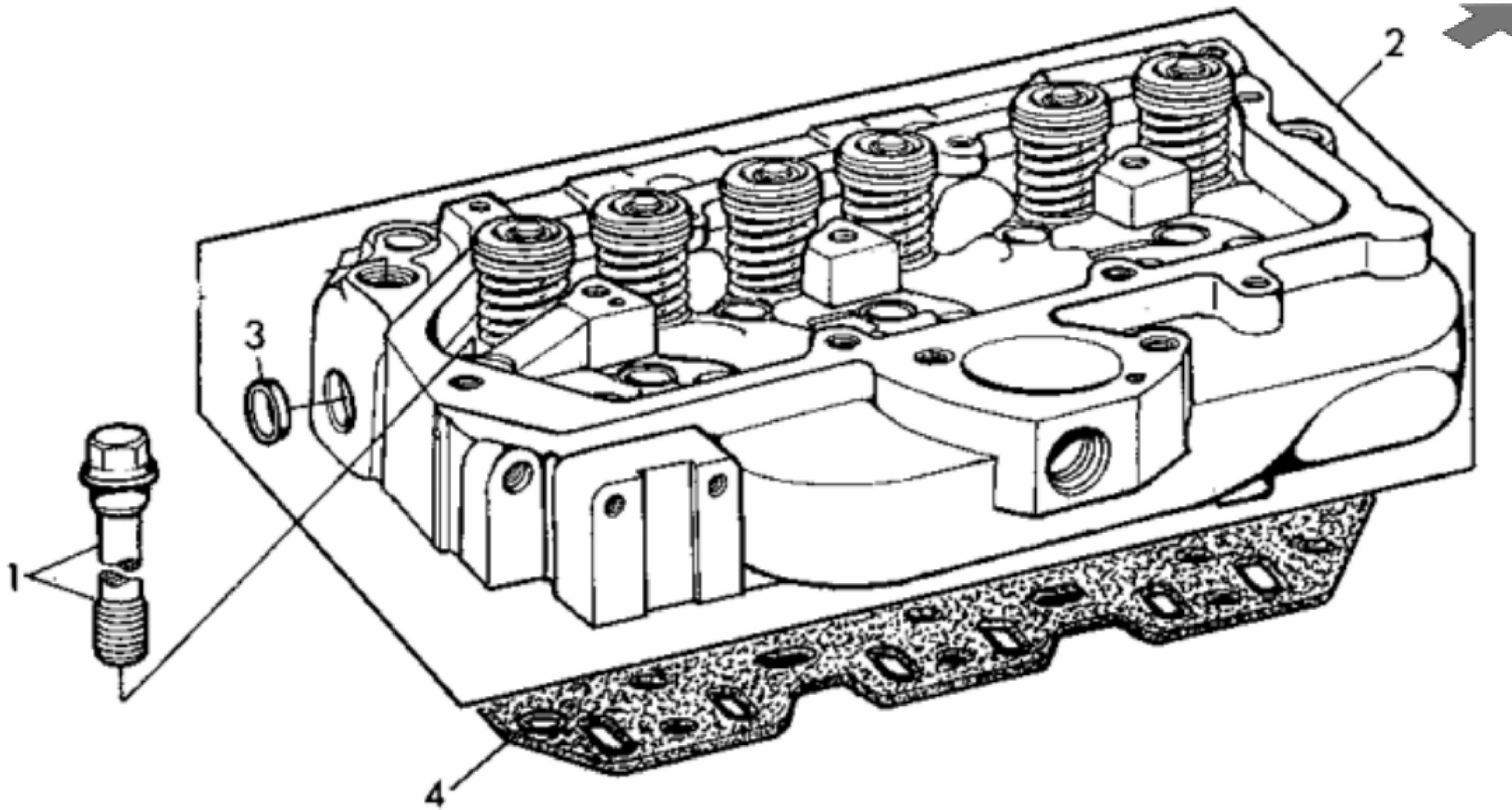

KEY	PART NO.	PART NAME	QTY	5310	5610	REMARKS	
1	R516516	CAP SCREW	14	X	X	12.7MM X 112MM	
2	RE507618	CYLINDER HEAD	1	X	X	(CYLINDER HEAD WITH INSERTS, INTAKE & EXHAUST VALVE, SPRING, SEAL & ROTATOR)	
3	CD16284	PLUG	1	X	X	OD=32.6MM	
4	R515090	ENGINE CYLINDER HEAD GASKET	1	X	X		

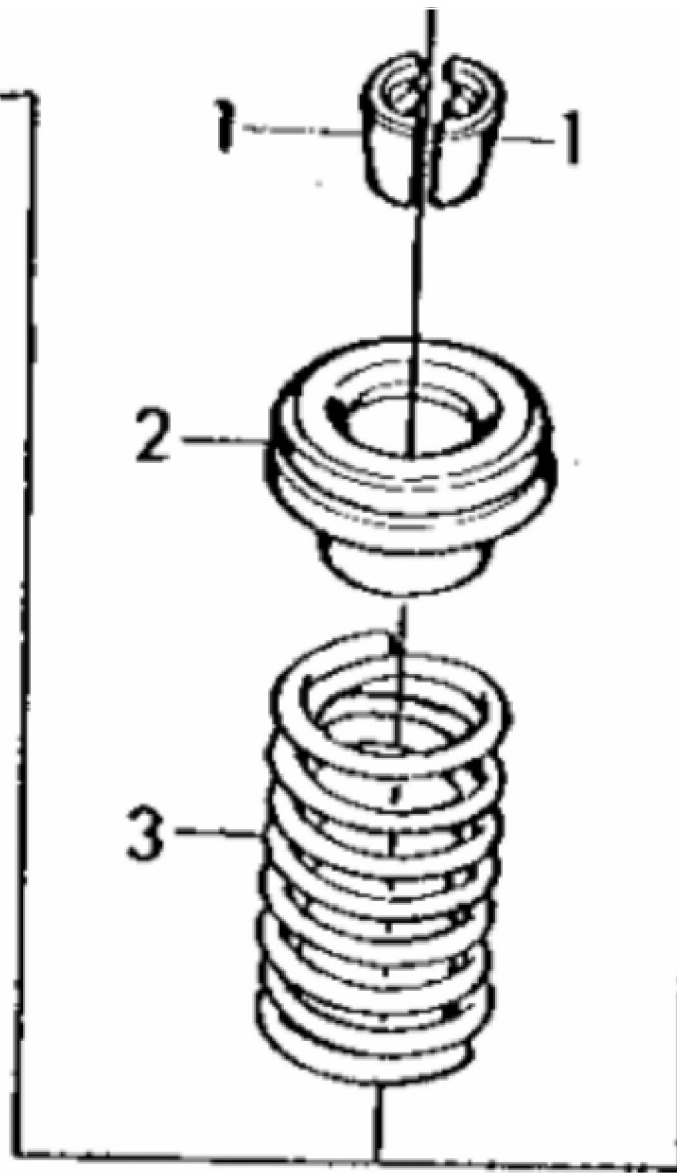
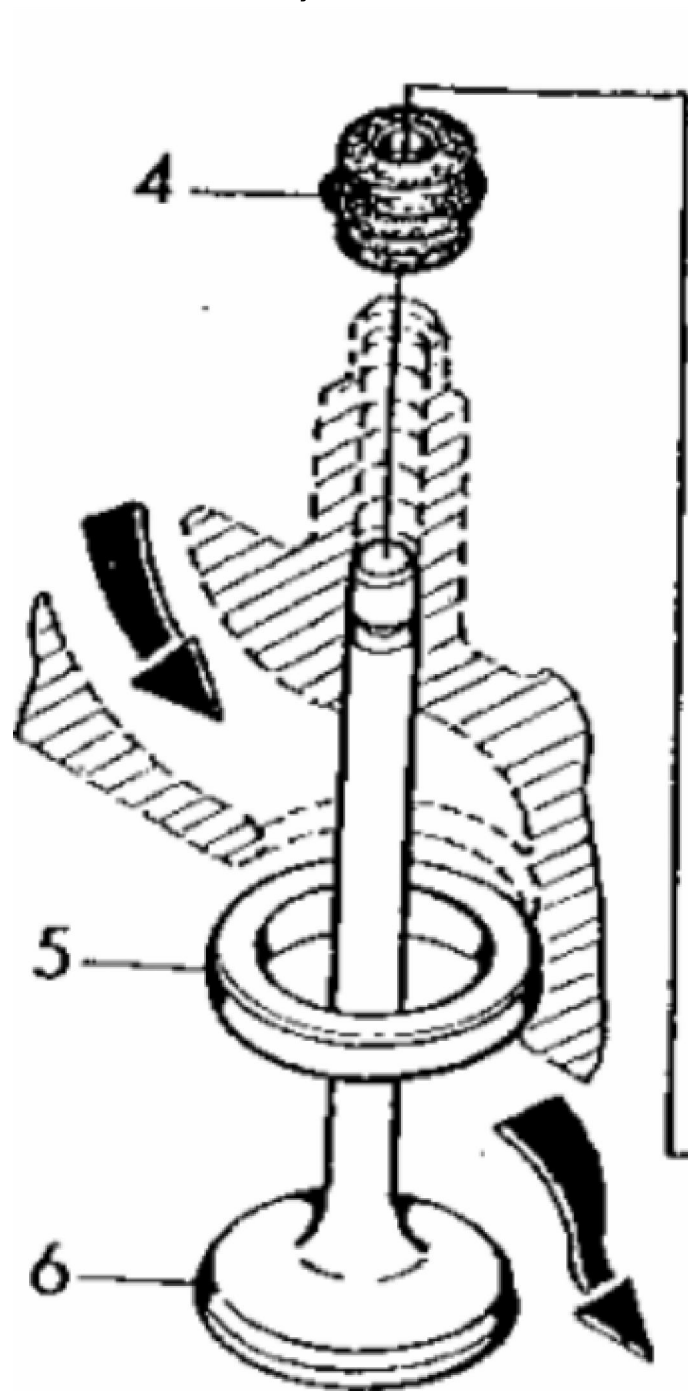

CD37204

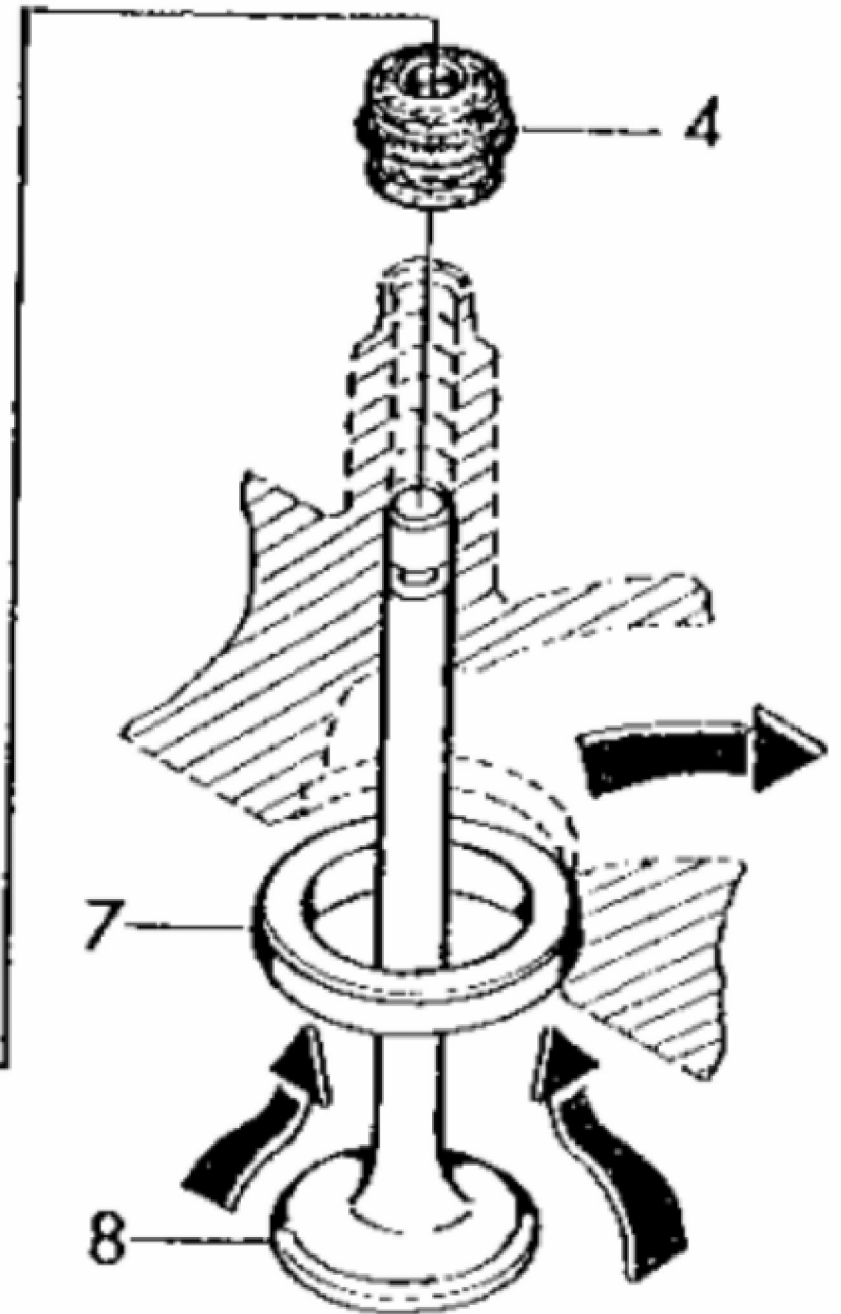



**Download the full PDF manual instantly.**

**Our customer service e-mail:**

**[aservicemanualpdf@yahoo.com](mailto:aservicemanualpdf@yahoo.com)**