

Update Date : 26-03-2020 Print Date : 01-03-2022

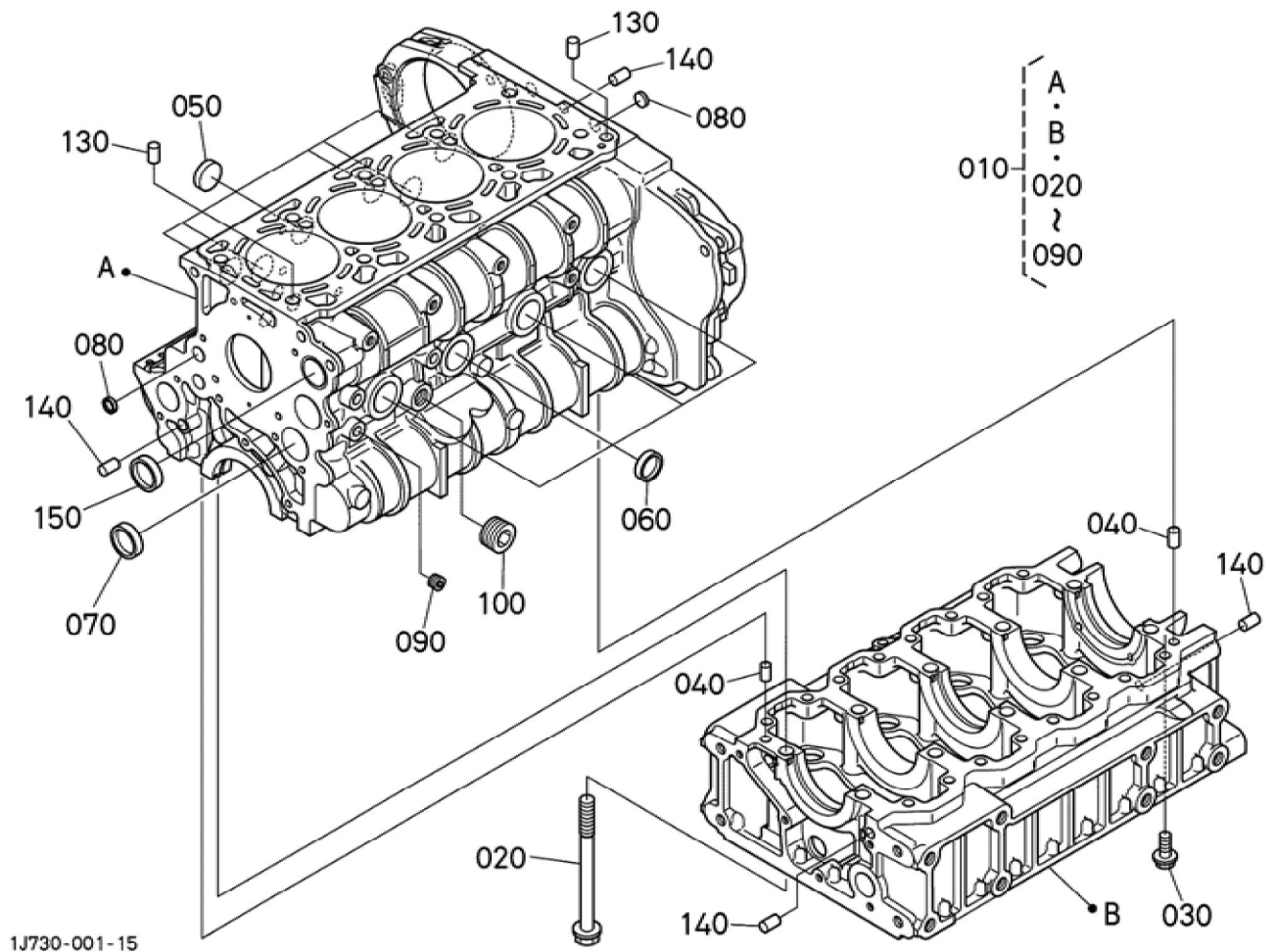

1J730-001-15

Update Date : 26-03-2020 Print Date : 01-03-2022

No.	Part Number	Part Name (POL)	Part Name (ENG)	QTY	IC	Serial No./PIN	Kg	Remarks
010	1J710-01020	GRP. KURBELGEH AEUSE	ASSY CRANKCASE	1		<=BKZ999	88.000	
010	1J730-01020	GRP. KURBELGEH AEUSE	ASSY CRANKCASE	1	>>	>=BL0001	78.000	
020	1J700-04560	BOLZEN	BOLT,CRANK CASE	10			0.145	
030	01774-51035	SCHRAUBE	BOLT,FLANG E	16		<=8JZZ999	0.030	
030	1J705-91020	SCHRAUBE	BOLT,FLANG E	16	NI	>=8KA0001	0.000	
040	05012-01016	ZYLINDERSTI FT	PIN STRAIGHT	2			0.010	
050	06311-85025	STOEPSEL,A BDICHTUNG	CAP,SEALING	6			0.010	
060	15321-96260	KAPPE	CAP,SEALING	4			0.014	
070	15221-03490	STOPFEN	CAP,SEALING	1			0.020	
080	06311-85016	STOEPSEL,A BDICHTUNG	CAP,SEALING	2			0.003	
090	15521-96020	STOPFEN	PLUG	1			0.003	
100	1A021-96020	STOPFEN	PLUG	1			0.020	
130	05012-01016	ZYLINDERSTI FT	PIN STRAIGHT	2			0.010	
140	05012-01016	ZYLINDERSTI FT	PIN STRAIGHT	4		<=AHZ999	0.010	
140	1G772-94520	ZYLINDERSTI FT	PIN,STRAIGH T	4	NI	>=AJ0001	0.010	
150	15221-03490	STOPFEN	CAP,SEALING	1			0.020	

Update Date : 26-03-2020 Print Date : 01-03-2022

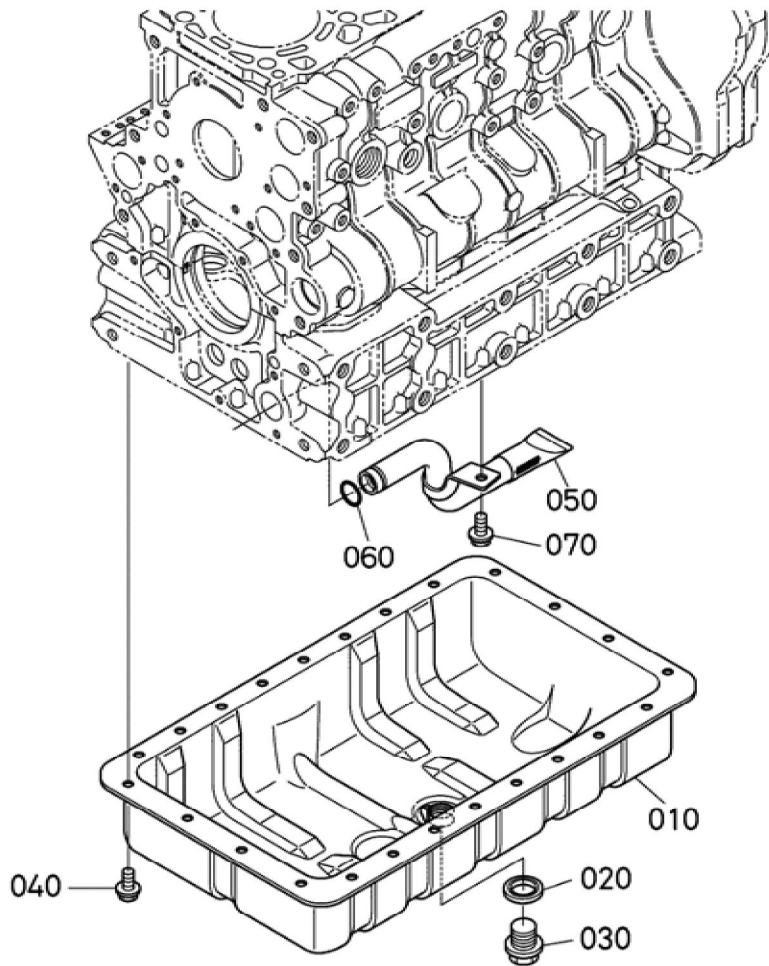

BKIDA5018 >> U55-4 (S/N 50006-54240) >> MOTOR / ENGINE >> 501000 OELWANNE / OIL PAN

Update Date : 26-03-2020 Print Date : 01-03-2022

No.	Part Number	Part Name (POL)	Part Name (ENG)	QTY	IC	Serial No./PIN	Kg	Remarks
010	1J730-01500	KOMP.OELW ANNE	COMP.OIL PAN	1			2.700	
020	16265-96670	DICHTUNG	PACKING	1		<=8JRZ999	0.010	
020	04717-02200	GUMMIUNTE RLAGE	WASHER,SEA L	1	>>	>=8JS0001	0.006	
030	15707-33750	ENTLEERUN GSSTOPFEN	PLUG(DRAIN)	1			0.095	
040	01755-50816	SCHRAUBE	BOLT,FLANG E	24			0.013	
050	1J700-32110	OELFILTER	FILTER,OIL	1			0.235	
060	04815-00180	O RING	O RING	1			0.003	
070	01755-50816	SCHRAUBE	BOLT,FLANG E	1			0.013	

Update Date : 26-03-2020 Print Date : 01-03-2022

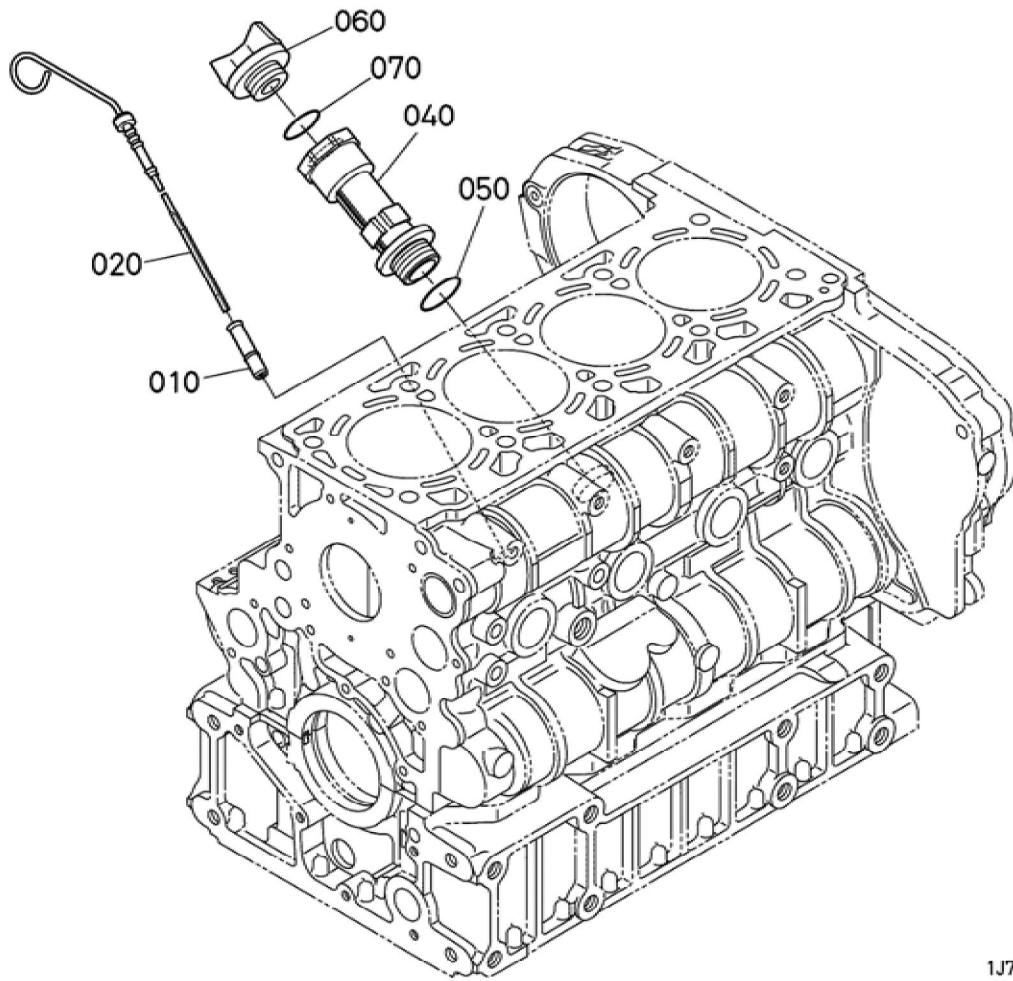

Update Date : 26-03-2020 Print Date : 01-03-2022

No.	Part Number	Part Name (POL)	Part Name (ENG)	QTY	IC	Serial No./PIN	Kg	Remarks
010	16809-36420	FUEHRUNG, OELMESSST AB	GUIDE (GAUGE,OIL)	1			0.028	
020	1J700-36410	OELMESSST AB	GAUGE,OIL	1			0.027	
040	15224-33110	OELFILTERFL ANSCH	FLANGE,OIL FILLER	1			0.158	
050	04814-50300	O RING	O RING	1			0.001	
060	E9151-33140	OELEINFUEL LSTOPFEN	PLUG(OIL FILLER)	1			0.017	
070	04814-50300	O RING	O RING	1		<=9ZZ999	0.001	
070	1J001-96770	O RING	O RING	1	>>	>=AA0001	0.001	

Update Date : 26-03-2020 Print Date : 01-03-2022

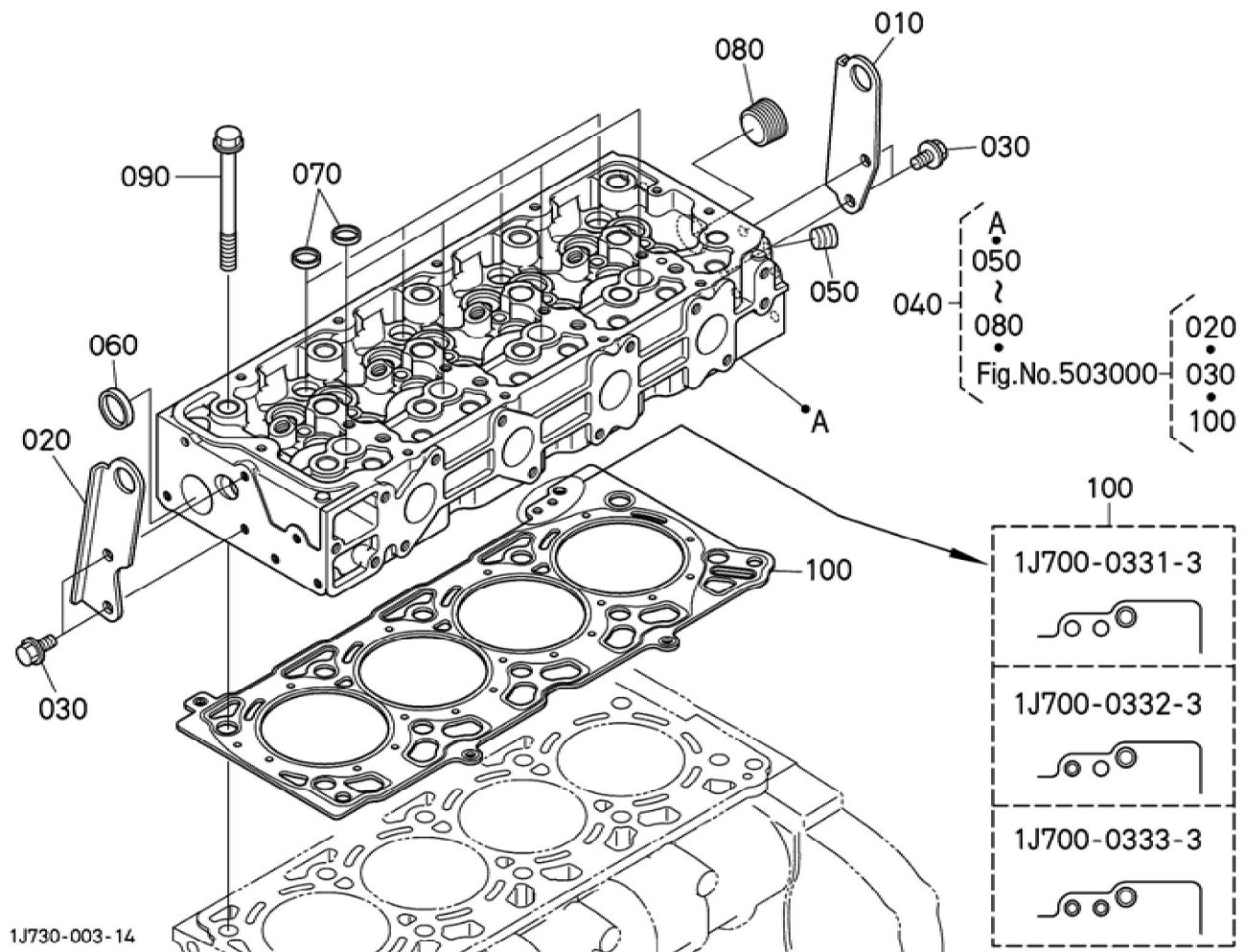

Update Date : 26-03-2020 Print Date : 01-03-2022

No.	Part Number	Part Name (POL)	Part Name (ENG)	QTY	IC	Serial No./PIN	Kg	Remarks
010	1J730-01740	MOTORHAKEN	HOOK,ENGINE	1			0.250	
020	1J730-01750	MOTORHAKEN	HOOK,ENGINE	1			0.200	
030	01754-50816	SCHRAUBE	BOLT,FLANGE	4			0.011	
040	1J701-03030	GRP.ZYLINDERKOPF	ASSY CYLINDER HEAD	1		<=CKZ999	25.000	SEE NOTE
040	1J701-03034	GRP.ZYLINDERKOPF	ASSY CYLINDER HEAD	1	NI	>=8CL0001	25.000	ORDER BY REF.No.040 NEW PART
040	1J701-03036	GRP.ZYLINDERKOPF	ASSY CYLINDER HEAD	1	>>	>=8GW0001	21.015	
050	07715-00401	KUGEL	BALL 1/4	1		<=ABZ999	0.001	
050	15521-96020	STOPFEN	PLUG	1	NI	>=AC0001	0.003	
060	15321-96260	KAPPE	CAP,SEALING	1			0.014	
070	16851-96270	KAPPE	CAP,SEALING	8			0.005	
080	16683-96020	STOPFEN	PLUG	1			0.088	
090	1J700-04560	BOLZEN	BOLT,CRANK CASE	10			0.145	
100	1J700-03310	ZYLINDERKOPFDICHTUNG	GASKET,CYLINDER HEAD	1		<=8JKZ999	0.165	0.1mm
100	1J700-03313	ZYLINDERKOPFDICHTUNG	GASKET,CYLINDER HEAD	1	>>	>=8JL0001	0.165	0.1mm
100	1J700-03320	ZYLINDERKOPFDICHTUNG	GASKET,CYLINDER HEAD	1		<=8JKZ999	0.190	0.2mm
100	1J700-03323	ZYLINDERKOPFDICHTUNG	GASKET,CYLINDER HEAD	1	>>	>=8JL0001	0.190	0.2mm
100	1J700-03330	ZYLINDERKOPFDICHTUNG	GASKET,CYLINDER HEAD	1		<=8JKZ999	0.220	0.3mm
100	1J700-03333	ZYLINDERKOPFDICHTUNG	GASKET,CYLINDER HEAD	1	>>	>=8JL0001	0.220	0.3mm

Update Date : 26-03-2020 Print Date : 01-03-2022

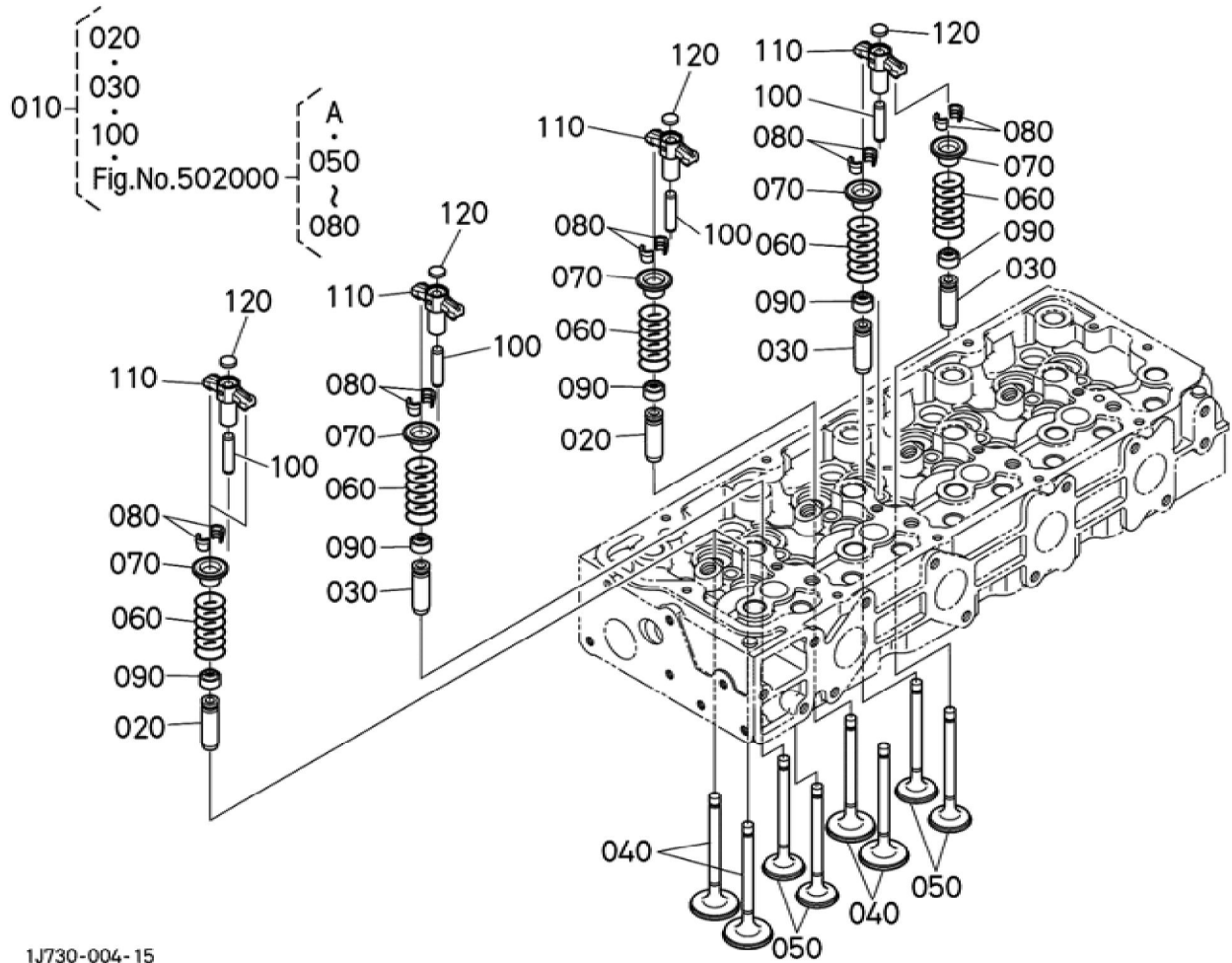

Update Date : 26-03-2020 Print Date : 01-03-2022

No.	Part Number	Part Name (POL)	Part Name (ENG)	QTY	IC	Serial No./PIN	Kg	Remarks
010	1J701-03030	GRP.ZYLINDERKOPF	ASSY CYLINDER HEAD	1		<=CKZ999	25.000	SEE NOTE
010	1J701-03034	GRP.ZYLINDERKOPF	ASSY CYLINDER HEAD	1	NI	>=8CL0001	25.000	ORDER BY REF.No.010 NEW PART
010	1J701-03036	GRP.ZYLINDERKOPF	ASSY CYLINDER HEAD	1	>>	>=8GW0001	21.015	
020	1J700-13540	EINLASSVENTILFUEHRUNG	GUIDE,VALVE ,INLET	8			0.014	
030	1J700-13560	AUSLASSVENTILFUEHRUNG	GUIDE,VALVE ,EXHAUST	8			0.014	
040	1J700-13110	EINLASSVENTIL	VALVE,INLET	8		<=8HHZ999	0.040	
040	1J700-13113	VENTIL	VALVE,INLET	8	>>	>=8HJ0001	0.040	
050	1J700-13120	AUSLASSVENTIL	VALVE,EXHAUST	8		<=8HHZ999	0.035	
050	1J700-13123	AUSLASSVENTIL	VALVE,EXHAUST	8	>>	>=8HJ0001	0.035	
060	1J700-13240	VENTIL-FEDER	SPRING,VALVE	16		<=8HRZ999	0.018	
060	1J705-13240	VENTIL-FEDER	SPRING	16	NI	>=8HS0001	0.010	
070	14601-13330	FEDER, HALTEBUEGEL	RETAINER (VALVE SPRING)	16			0.010	
080	14601-13980	KLEMMSCHEIBE	COLLET,VALVE SPRING	16			0.001	SET
090	11420-13150	VENTILDICHTUNG	SEAL(VALVE STEM)	16			0.002	
100	1J700-13480	WELLE	SHAFT,VALVE	8			0.016	
110	1J700-13462	HUBARM, VENTIL	ARM,VALVE BRIGE	8		<=8HBZ999	0.039	
110	1J700-13463	HUBARM, VENTIL	ARM,VALVE BRIGE	8	>>	>=8HC0001	0.039	
110	1J705-13460	HUBARM, VENTIL	ARM	8	NI	>=8HS0001	0.040	
120	1J700-13492	PUFFER	PAD	8			0.003	



Download the full PDF manual instantly.

Our customer service e-mail:

aservicemanualpdf@yahoo.com