

## BKIDK0511 &gt;&gt; STV40 &gt;&gt; MOTOR / ENGINE &gt;&gt; 000103 KURBELGHAEUSE / CRANKCASE

Update Date : 2019/01/17 Print Date : 2022/03/16

No.	Part Number	Part Name (POL)	Part Name (ENG)	QTY	IC	Serial No./PIN	Kg	Remarks
010	1G847-01012	KOMP.KURBELGEHAEUSE	COMP.CRANKCASE	1		<=6A0508	48.500	
010	1G847-01013	KOMP.KURBELGEHAEUSE	COMP.CRANKCASE	1	>>	>=6C0001	48.500	
010	1G847-01014	KOMP.KURBELGEHAEUSE	COMP.CRANKCASE	1	>>	>=AC0001	48.500	
010	1G847-01015	KOMP.KURBELGEHAEUSE	COMP.CRANKCASE	1	>>	>=BL0001	48.500	
010	1A388-01010	KOMP.KURBELGEHAEUSE	CRANKCASE, COMP	1	>>	>=7EA0001	0.000	
020	15521-96020	STOPFEN	PLUG	5			0.003	
030	15521-96030	STOPFEN	PLUG	2			0.007	
040	17391-96160	STOPFEN	PLUG,EXPANSION	3			0.003	
050	16271-96160	STOPFEN	PLUG,EXPANSION	1			0.025	
060	15221-03380	STOPFEN	CAP,SEALING	5			0.017	
070	15221-03390	STOPFEN	CAP,SEALING	2			0.030	
080	05012-00408	ZYLINDERSTIFT	PIN,STRAIGHT	2			0.001	
090	05012-00609	ZYLINDERSTIFT	PIN,STRAIGHT	3			0.003	
100	05012-00612	ZYLINDERSTIFT	PIN, STRAIGHT	2			0.003	
110	05012-01018	ZYLINDERSTIFT	PIN,STRAIGHT	2			0.012	
120	15221-33650	ROHRSTIFT	PIN,PIPE	1			0.004	
130	06312-10020	STOPFEN	W-PLUG	1			0.016	
140	15469-33610	STOPFEN	PLUG	1		<=9N0663	0.008	
140	1G896-33610	BOLZEN	PLUG	1	>>	>=9Q0001	0.008	
150	15021-33660	DICHTUNGSPLATTE	PACKING	1			0.001	
160	16427-33140	OELEINFUELLSSTOPFEN	PLUG,OIL FILLER	1		<=5C0803	0.025	
160	16427-33142	OELEINFUELLSSTOPFEN	PLUG(OIL FILLER)	1	>>	>=5E0001	0.025	
160	1J860-33140	OELEINFUELLSSTOPFEN	PLUG,OIL FILLER	1	>>	>=9Y0001	0.030	

## BKIDK0511 &gt;&gt; STV40 &gt;&gt; MOTOR / ENGINE &gt;&gt; 000103 KURBELGHAUSE / CRANKCASE

Update Date : 2019/01/17 Print Date : 2022/03/16

No.	Part Number	Part Name (POL)	Part Name (ENG)	QTY	IC	Serial No./PIN	Kg	Remarks
170	1A021-33110	FLANSCH	FLANGE,OIL FILLER	1			0.070	
180	1A021-51660	DICHTUNGSP LATTE	GASKET, PUMP COVER	1			0.003	
190	01023-50618	BOLZEN	BOLT,SEMS	1			0.006	
200	15471-35012	GRP.OELPUM PE	ASSY PUMP OIL	1		<=4L0509	0.550	
200	15471-35013	GRP.OELPUM PE	ASSY PUMP,OIL	1	>>	>=4N0001	0.550	
210	1A021-35150	DICHTUNGSP LATTE	GASKET,OIL PUMP	1			0.001	
220	01023-50650	BOLZEN	BOLT,SEMS	4			0.012	
230	19202-35660	ZAHNRAD	GEAR OIL PUMP DRIVE	1		<=BPZ999	0.230	
230	1G896-35660	ZAHNRAD	GEAR,OIL PUMP DRIVE	1	>>	>=BQ0001	0.135	
240	05712-00410	KEIL	KEY,FEATHER	1			0.001	
250	15221-35682	MUTTER	NUT	1			0.014	
260	1A021-57483	TRAEGER	BRACKET (ACCEL.CABLE)	1			0.125	
270	01023-50622	BOLZEN	BOLT,SEMS	3			0.005	

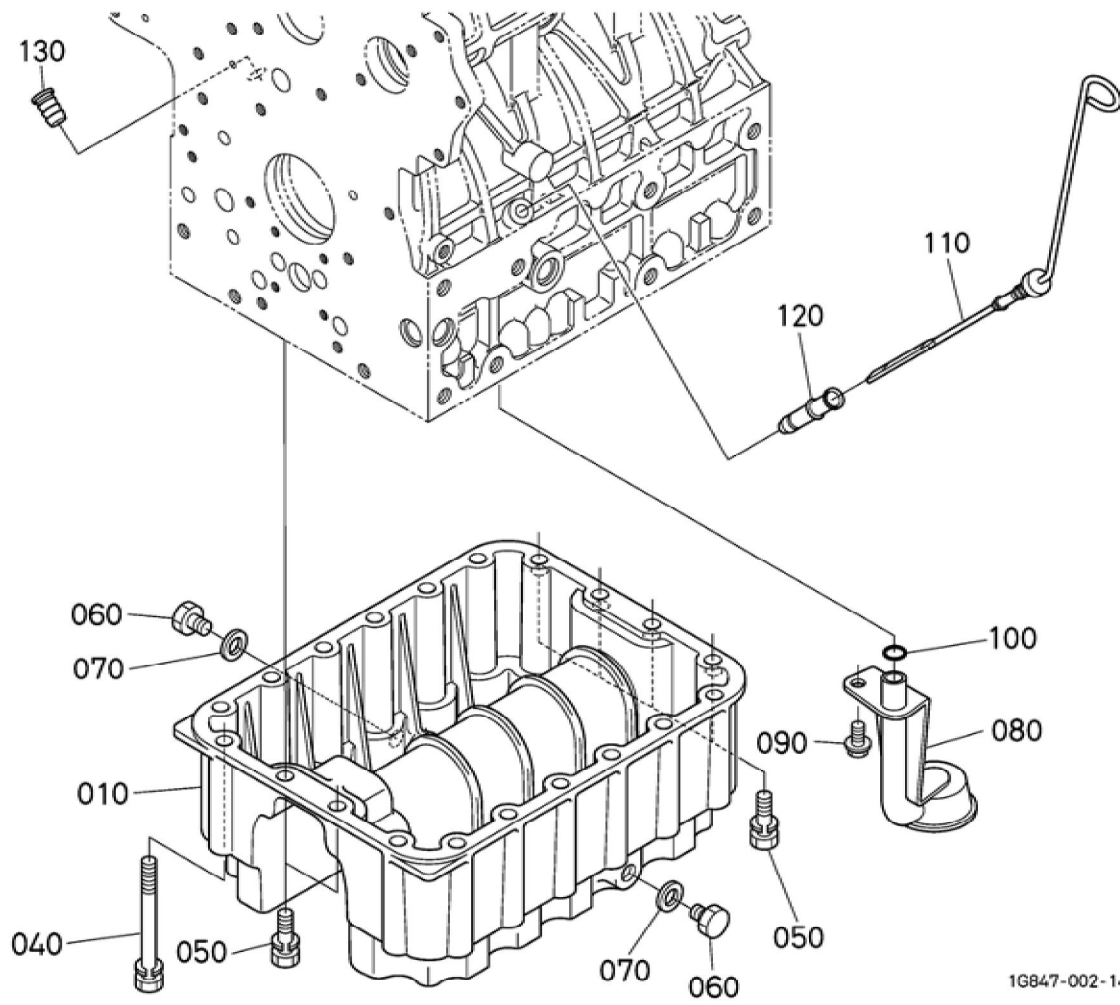

## BKIDK0511 &gt;&gt; STV40 &gt;&gt; MOTOR / ENGINE &gt;&gt; 000200 OL-FANGER / OIL PAN

Update Date : 2019/01/17 Print Date : 2022/03/16

No.	Part Number	Part Name (POL)	Part Name (ENG)	QTY	IC	Serial No./PIN	Kg	Remarks
010	1G842-01613	OELWANNE	OIL PAN	1		<=8DZ999	3.650	
010	1J830-01610	OELWANNE	OIL PAN	1	>>	>=8E0001	3.550	
040	01133-51002	BOLZEN	BOLT,SEMS	14		<=5Q0430	0.070	
040	1G805-91010	BOLZEN	BOLT,SEMS	14	>>	>=5S0001	0.067	BESTELLEN SIE BITTE POS.040 NEUE TEILE
040	01133-51002	BOLZEN	BOLT,SEMS	14	>>		0.070	
050	01133-51028	BOLZEN	BOLT,SEMS	6		<=5Q0430	0.027	
050	1A091-91010	BOLZEN	BOLT,SEMS	6	>>	>=5S0001	0.025	
060	16427-33750	ENTLEERUN GSSTOPFEN	PLUG,DRAIN	2			0.030	
070	6C090-58960	DICHTUNGSP LATTE	GASKET	2			0.005	
080	1A024-32110	OELFILTER	FILTER(OIL)	1			0.220	
090	01123-60814	BOLZEN	BOLT	1		<=5U0961	0.010	
090	01754-50812	SCHRAUBE	BOLT,FLANG E	1	NI	>=5W0001	0.010	
100	04817-00160	O RING	O RING	1			0.001	
110	1A033-36413	OELMESSST AB	GAUGE,OIL	1			0.050	
120	17456-36420	FUEHRUNG, OELMESSST AB	GUIDE (GAUGE,OIL)	1			0.030	
130	16414-33640	STOPFEN, OELMESSST AB	PLUG,OIL GAUGE	1		<=4ZZ999	0.003	
130	1G513-36550	STOPFEN, OELMESSST AB	PLUG,OIL GAUGE	1	>>	>=5A0001	0.004	

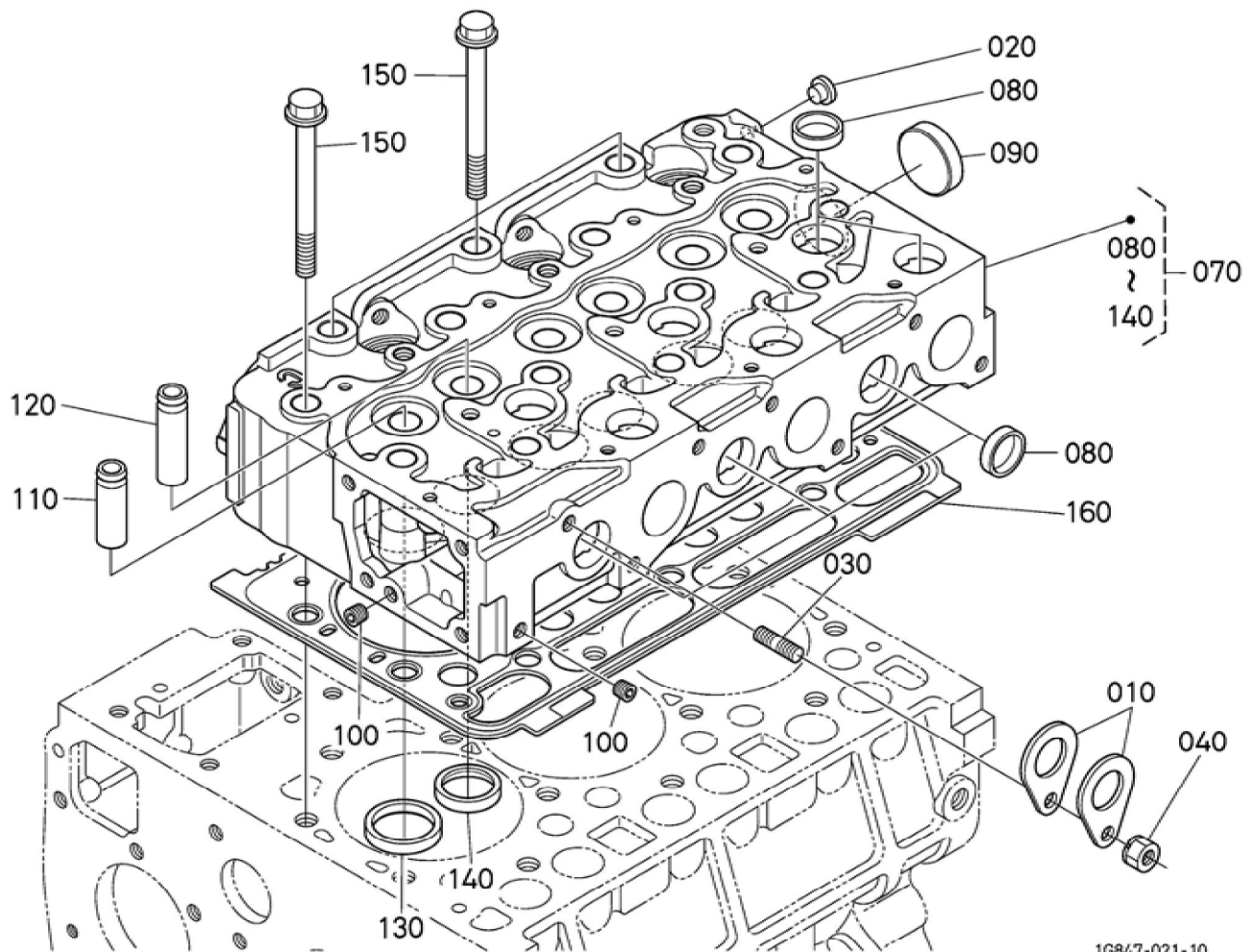

## BKIDK0511 &gt;&gt; STV40 &gt;&gt; MOTOR / ENGINE &gt;&gt; 000302 ZYLINDERKOPF / CYLINDER HEAD

Update Date : 2019/01/17 Print Date : 2022/03/16

No.	Part Number	Part Name (POL)	Part Name (ENG)	QTY	IC	Serial No./PIN	Kg	Remarks
010	15221-01750	MOTORHAKE N	HOOK,ENGINE	2			0.040	
020	09980-10075	KAPPE	CAP,PROTECTOR	1			0.001	
030	15471-91530	STEBBOLZEN	BOLT,STUD	1			0.010	
040	02156-50080	MUTTER	HEX.NUT	1		<=7DMZ999	0.004	
040	16429-92010	MUTTER	NUT WITH LOCK WASHER	1	>>	>=7DN0001	0.007	
070	1G841-03043	KOMP.ZYLINDERKOPF	HEAD,CYLINDER	1			15.000	
080	15221-03370	STOPFEN	PLUG,CUP TYPE	9			0.010	
090	15221-03490	STOPFEN	CAP,SEALING	1			0.020	
100	15261-96010	STOPFEN	PLUG	2			0.002	
110	17321-13580	EINLASSVENTILFUEHRUNG	GUIDE,VALVE (INLET)	3		<=AL1665	0.015	
110	1G896-13580	EINLASSVENTILFUEHRUNG	GUIDE,VALVE ,INLET	3	>>	>=AN0001	0.020	
120	17321-13560	AUSLASSVENTILFUEHRUNG	GUIDE,EXHAUST VALVE	3		<=5FZ999	0.020	
120	1C010-13560	AUSLASSVENTILFUEHRUNG	GUIDE,EXHAUST VALVE	3	>>	>=5G0001	0.025	
130	16415-13620	VENTILSITZ, EINLASSVENTIL	SEAT,VALVE (INLET)	3			0.010	
140	16415-13612	VENTILSITZ, AUSLASSVENTIL	SEAT (EXHAUST VALVE)	3			0.010	
150	19013-03450	ZYLINDERKOPFSCHRAUBE	BOLT,HEAD (CYLINDER)	14			0.077	
160	1G750-03312	ZYLINDERKOPFDICHTUNG	GASKET,CYL. HEAD	1			0.220	

Update Date : 2019/01/17 Print Date : 2022/03/16

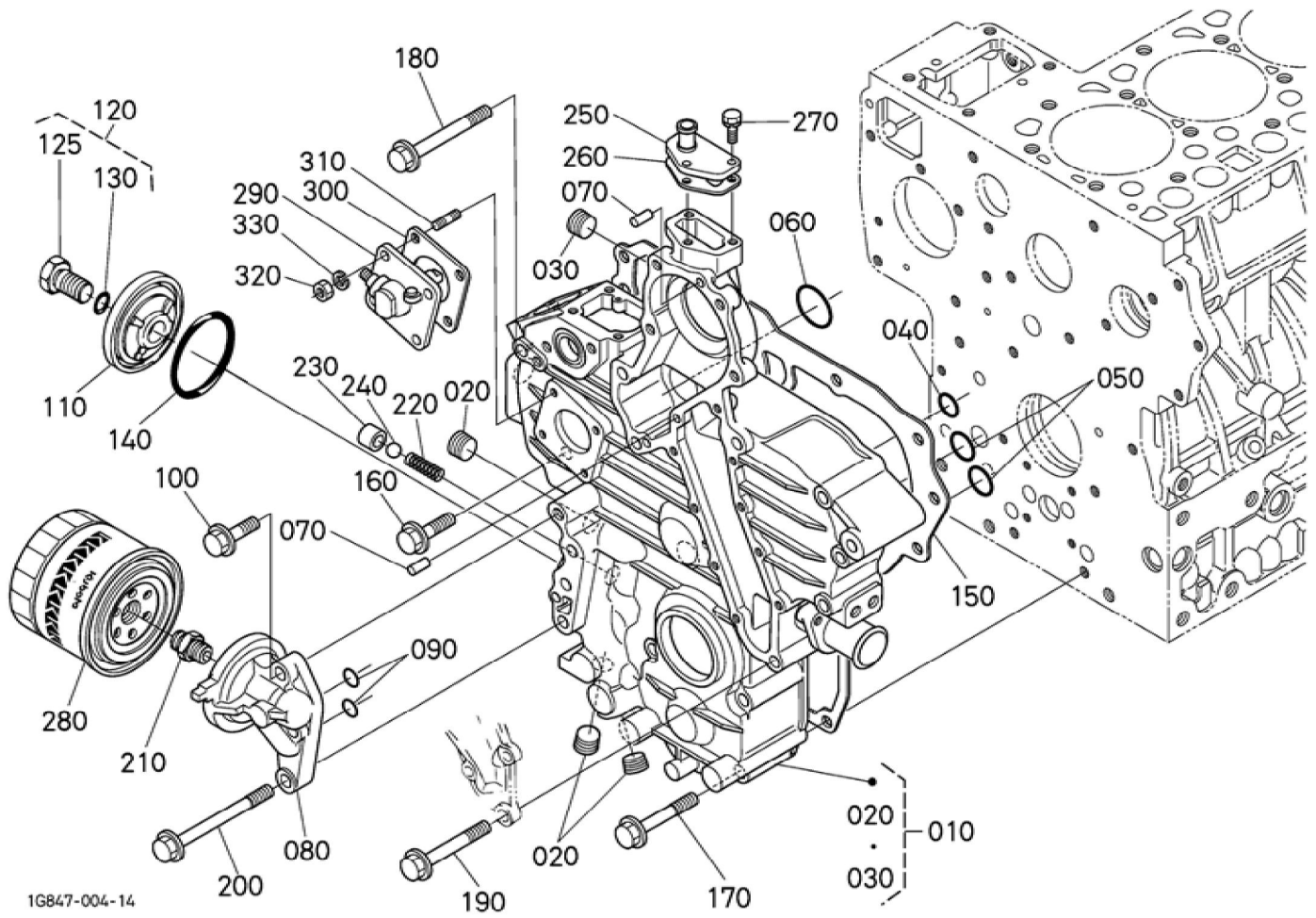

1G847-004-14



Update Date : 2019/01/17 Print Date : 2022/03/16

No.	Part Number	Part Name (POL)	Part Name (ENG)	QTY	IC	Serial No./PIN	Kg	Remarks
010	1G847-04023	KMP.GETRIEBEGEHAEUSE	COMP.CASE, GEAR	1		<=5J0751	3.800	
010	1G847-04024	KMP.GETRIEBEGEHAEUSE	COMP.CASE, GEAR	1	>>	>=5L0001	3.800	
020	16241-96020	STOPFEN	PLUG	3			0.015	
030	1A021-96020	STOPFEN	PLUG	1			0.020	
040	04817-00150	O RING	O RING	1			0.001	
050	04817-00220	O RING	O RING	2			0.001	
060	04817-00360	O RING	O-RING	1			0.001	
070	05012-00612	ZYLINDERSTIFT	PIN, STRAIGHT	2			0.003	
080	1A021-32610	HALTER, OELFILTER	BASE,OIL FILTER	1			0.250	
080	1G742-32610	HALTER, OELFILTER	BASE,OIL FILTER	1	=	<=6L0844	0.245	
080	1G742-32613	HALTER, OELFILTER	BASE(OIL FILTER)	1	>>	>=6N0001	0.245	
080	1G742-32614	HALTER, OELFILTER	BASE(OIL FILTER)	1	>>	>=8L0001	0.245	
090	04817-00150	O RING	O RING	2			0.001	
100	01123-50835	BOLZEN	BOLT,SEMS	1		<=6J0547	0.020	
100	01754-50830	SCHRAUBE	BOLT,FLANGE	1	>>	>=6L0001	0.050	
110	17331-32880	DECKEL	COVER	1			0.075	
120	17331-32910	KOMP.BOLZEN	BOLT,COMP	1			0.070	
125	17331-32900	BOLZEN	BOLT	1			0.060	
130	04817-00150	O RING	O RING	1			0.001	
140	19202-96830	O RING	O-RING	1			0.010	
150	1A021-04130	DICHTUNG	GASKET (CASE,GEAR)	1			0.019	
160	01123-50835	BOLZEN	BOLT,SEMS	1		<=5U0961	0.020	
160	01754-50830	SCHRAUBE	BOLT,FLANGE	1	>>	>=5W0001	0.050	
170	01123-50870	BOLZEN	BOLT,SEMS	7		<=5U0961	0.029	
170	1A021-91030	SCHRAUBE	BOLT,SEMS	7	>>	>=5W0001	0.030	
180	17367-91010	BOLZEN	BOLT	2		<=5U0961	0.005	

Update Date : 2019/01/17 Print Date : 2022/03/16

No.	Part Number	Part Name (POL)	Part Name (ENG)	QTY	IC	Serial No./PIN	Kg	Remarks
180	01754-50875	SCHRAUBE	BOLT,FLANGE	2	>>	>=5W0001	0.030	
190	17367-91020	BOLZEN	BOLT	3		<=5U0961	0.035	
190	01754-50885	SCHRAUBE	BOLT,FLANGE	3	>>	>=5W0001	0.032	
200	1A021-91010	BOLZEN	BOLT	2		<=5U0961	0.045	
200	1A021-91040	SCHRAUBE	BOLT	2	>>	>=5W0001	0.045	
210	1A021-32290	VERBINDUNG SSTUECK	PIPE(JOINT)	1			0.050	
220	15241-36950	FEDER	SPRING	1			0.004	
230	15521-36930	SITZ,VENTIL	SEAT,VALVE	1			0.015	
240	07715-03213	KUGEL	BALL	1			0.004	
250	15521-73320	FLANSCH	FLANGE (WATER RETURN)	1			0.040	
260	1A021-73330	DICHTUNGSP LATTE	GASKET (RETURN FLANGE)	1		<=7E0375	0.001	
260	1A021-73332	DICHTUNGSP LATTE	GASKET (RETURN FLANGE)	1	>>	>=7G0001	0.001	
270	01023-50620	BOLZEN	BOLT,SEMS	3			0.006	
280	16414-32430	OELFILTERP ATRONE	CARTRIDGE, OIL FILTER	1			0.450	
280	HH164-32430	OELFILTERP ATRONE	FILTER (CARTRIDGE, OIL)	1	>>		0.500	
290	38240-34660	GEHAUEUSE, STUNDENZA EHLERANTRI EB	CASE,GEAR, ASSY(H/M)	1			0.335	
300	1G751-88130	DICHTUNG	GASKET (H/METER)	1			0.001	
310	15221-88210	STEBOLZEN	STUD	4			0.005	
320	02056-50060	MUTTER	HEX.NUT	4			0.002	
330	04512-60060	FEDERRING	WASHER SPRING	4			0.001	

Update Date : 2019/01/17 Print Date : 2022/03/16

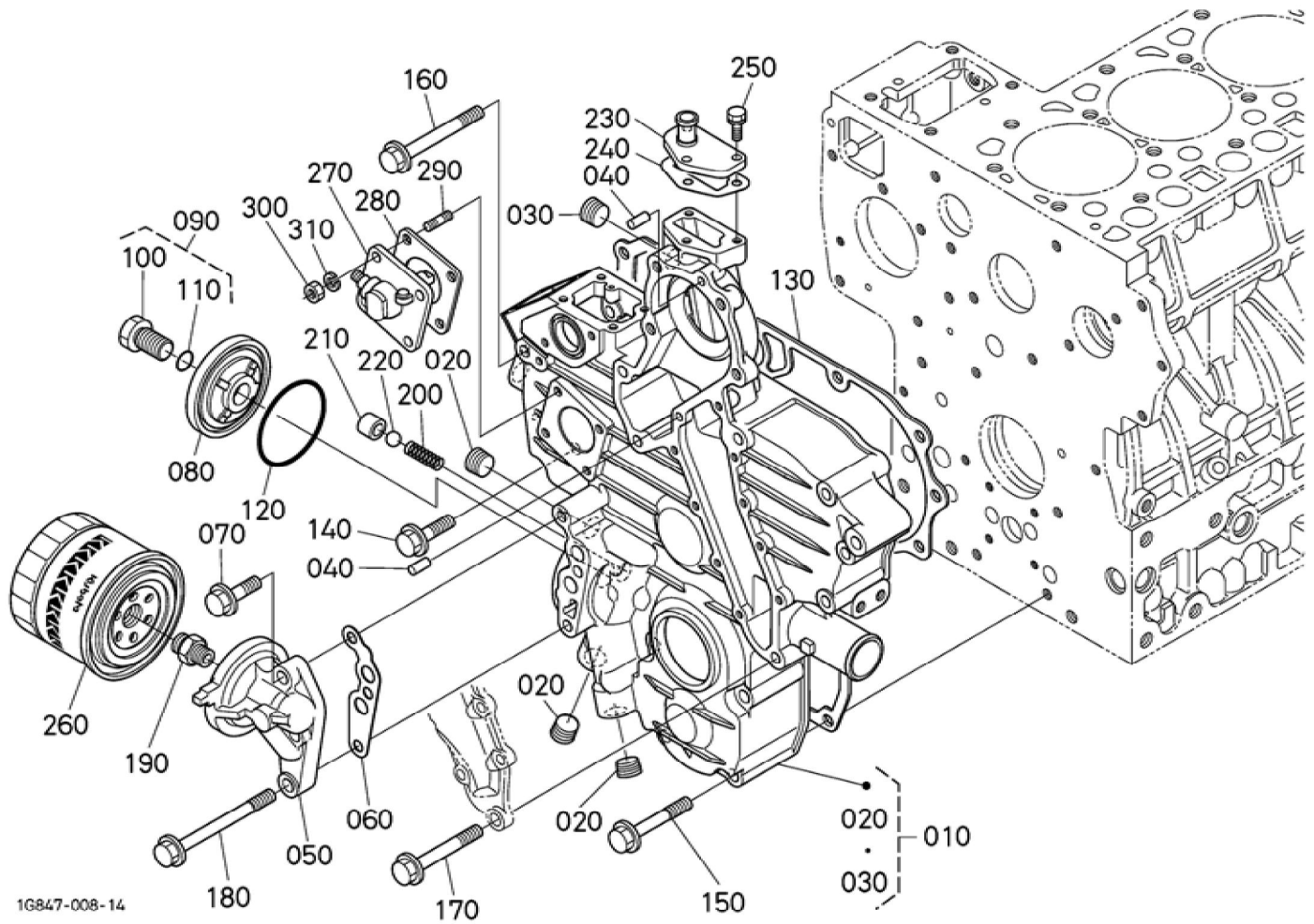

1G847-008-14

Update Date : 2019/01/17 Print Date : 2022/03/16

No.	Part Number	Part Name (POL)	Part Name (ENG)	QTY	IC	Serial No./PIN	Kg	Remarks
010	1G847-04025	KMP.GETRIEBEGEHAEUSE	COMP.CASE, GEAR	1		<=AE1345	3.800	
010	1J830-04020	KMP.GETRIEBEGEHAEUSE	COMP.CASE, GEAR	1	>>	>=AG0001	3.700	
010	1J830-04022	KMP.GETRIEBEGEHAEUSE	COMP.CASE, GEAR	1	NI	>=BY0001	3.700	
020	16241-96020	STOPFEN	PLUG	3			0.015	
030	1A021-96020	STOPFEN	PLUG	1			0.020	
040	05012-00612	ZYLINDERSTIFT	PIN, STRAIGHT	2			0.003	
050	1G742-32614	HALTER, OELFILTER	BASE(OIL FILTER)	1		<=BA0897	0.245	BESTELLEN SIE BITTE POS.050 UND 060 NEUE TEILE
050	1G742-32615	HALTER, OELFILTER	BASE,OIL FILTER	1	NI	>=BC0001	0.245	
060	04817-00150	O RING	O RING	2		<=BA0897	0.001	
060	1J860-32620	DICHTUNGSPLATTE	GASKET(OIL FILTER BASE)	1	NI	>=BC0001	0.002	
070	01754-50830	SCHRAUBE	BOLT,FLANGE	1			0.050	
080	17331-32880	DECKEL	COVER	1			0.075	
090	17331-32910	KOMP.BOLZEN	BOLT,COMP	1			0.070	
100	17331-32900	BOLZEN	BOLT	1			0.060	
110	04817-00150	O RING	O RING	1			0.001	
120	19202-96830	O RING	O RING	1			0.010	
130	1G701-04130	DICHTUNG	GASKET,GEAR CASE	1			0.021	
140	01754-50830	SCHRAUBE	BOLT,FLANGE	1			0.050	
150	1A021-91030	SCHRAUBE	BOLT,SEMS	7			0.030	
160	01754-50875	SCHRAUBE	BOLT,FLANGE	2			0.030	
170	01754-50885	SCHRAUBE	BOLT,FLANGE	3			0.032	
180	1A021-91040	SCHRAUBE	BOLT	2			0.045	
190	1A021-32290	VERBINDUNGSSTUECK	PIPE(JOINT)	1			0.050	

Update Date : 2019/01/17 Print Date : 2022/03/16

No.	Part Number	Part Name (POL)	Part Name (ENG)	QTY	IC	Serial No./PIN	Kg	Remarks
200	15241-36950	FEDER	SPRING	1			0.004	
210	15521-36930	SITZ,VENTIL	SEAT,VALVE	1			0.015	
220	07715-03213	KUGEL	BALL	1			0.004	
230	15521-73320	FLANSCH	FLANGE,WAT ER RETURN	1			0.040	
240	1A021-73332	DICHTUNGSP LATTE	GASKET (RETURN FLANGE)	1			0.001	
250	01023-50620	BOLZEN	BOLT,SEMS	3			0.006	
260	HH164-32430	OELFILTERP ATRONE	FILTER (CARTRIDGE, OIL)	1		<=7CRZ999	0.500	
270	38240-34660	GEHAEUSE, STUNDENZA EHLERANTRI EB	ASSY HOUR METER GEAR	1		<=7CRZ999	0.335	
270	1J854-83300	GEHAEUSE, BETRIEBSST UNDENZAEH LER	METER,HOU R	1	>>	>=7CS0001	0.180	
280	1G751-88130	DICHTUNG	GASKET (H/METER)	1			0.001	
290	15221-88210	STEBOLZEN	BOLT,STUD	4			0.005	
300	02056-50060	MUTTER	HEX.NUT	4			0.002	
310	04512-50060	FEDERRING	WASHER,SP RING LOCK	4			0.001	

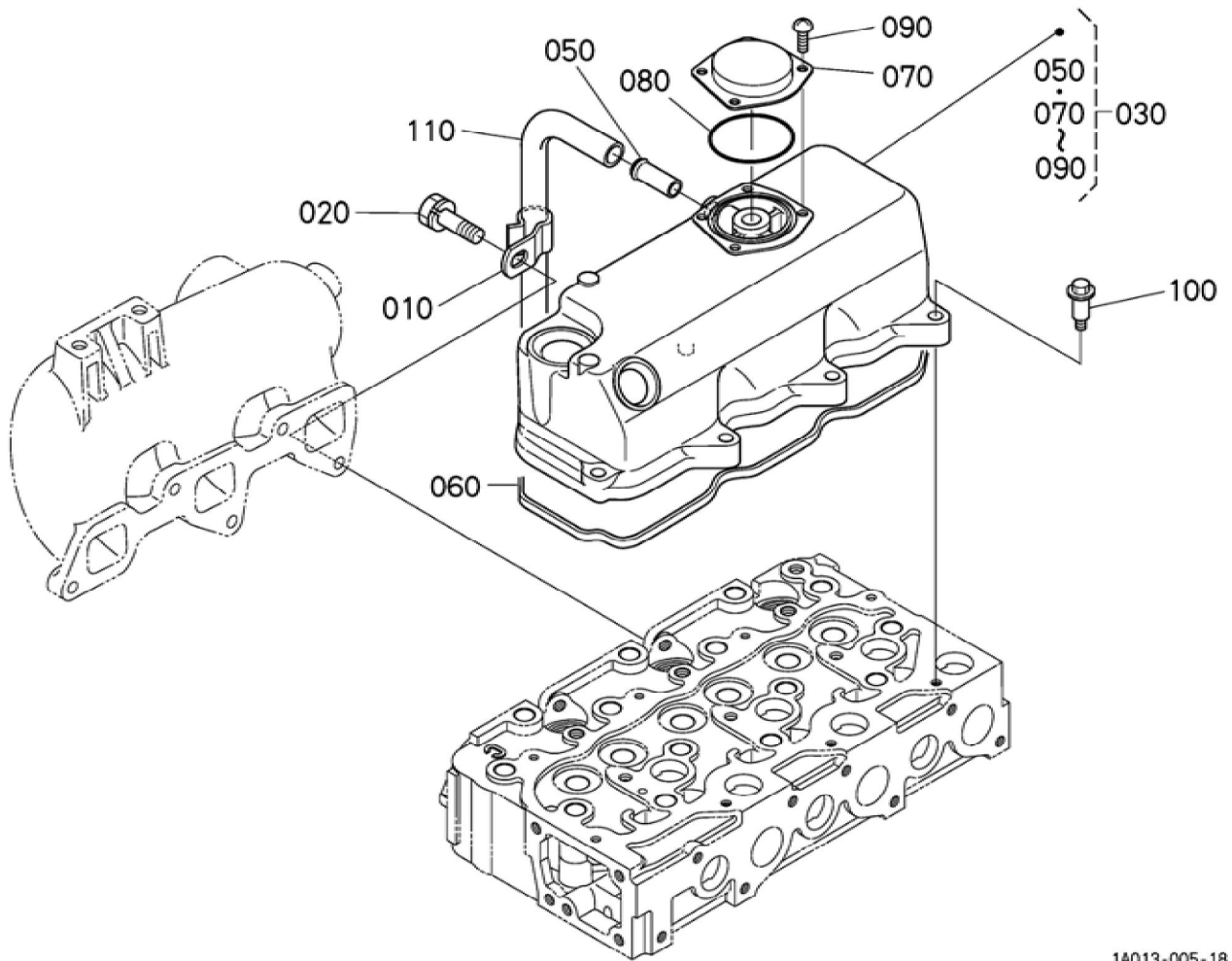

## BKIDK0511 &gt;&gt; STV40 &gt;&gt; MOTOR / ENGINE &gt;&gt; 000500 VENTILDECKEL / HEAD COVER

Update Date : 2019/01/17 Print Date : 2022/03/16

No.	Part Number	Part Name (POL)	Part Name (ENG)	QTY	IC	Serial No./PIN	Kg	Remarks
010	1A091-05580	KLAMMER	CLAMP	1			0.006	
020	01123-50822	BOLZEN	BOLT,SEMS	1			0.012	
030	1A021-14503	VENTILDECKEL	COVER,HEAD,ASSY (CYLINDER)	1		<=AE1345	1.240	
030	1A021-14505	VENTILDECKEL	ASSY COVER,CYL. HEAD	1	>>	>=AG0001	1.240	
050	17331-73342	WASSERROHR	PIPE,WATER RETURN	1			0.010	
060	1A021-14520	VENTILDECKELDICHUNG	GASKET,HEAD COVER	1		<=4Y0751	0.020	
060	1A021-14523	VENTILDECKELDICHUNG	GASKET (COVER,HEAD)	1	>>	>=5A0001	0.020	
070	1A021-05120	ENTLUEFTERDECKEL	COVER,BREATH ER	1		<=4TZ999	0.039	
070	1G742-05120	ENTLUEFTERDECKEL	COVER,BREATH ER	1	>>	>=4U0001	0.035	
080	1A021-05430	O RING	O RING,BREATH ER	1			0.001	
090	03024-50510	SCHRAUBE	SCREW,SEMS (PAN HEAD)	4		<=9Y0889	0.002	
090	03054-50510	SCHRAUBE	SCREW,PAN HEAD (PHILLIPS)	4	>>	>=AA0001	0.003	
100	1G911-91022	BOLZEN	BOLT	8			0.015	
110	15837-05510	ENTLUEFTUNGSRÖHR	PIPE,BREATH ER	1			0.060	

Update Date : 2019/01/17 Print Date : 2022/03/16

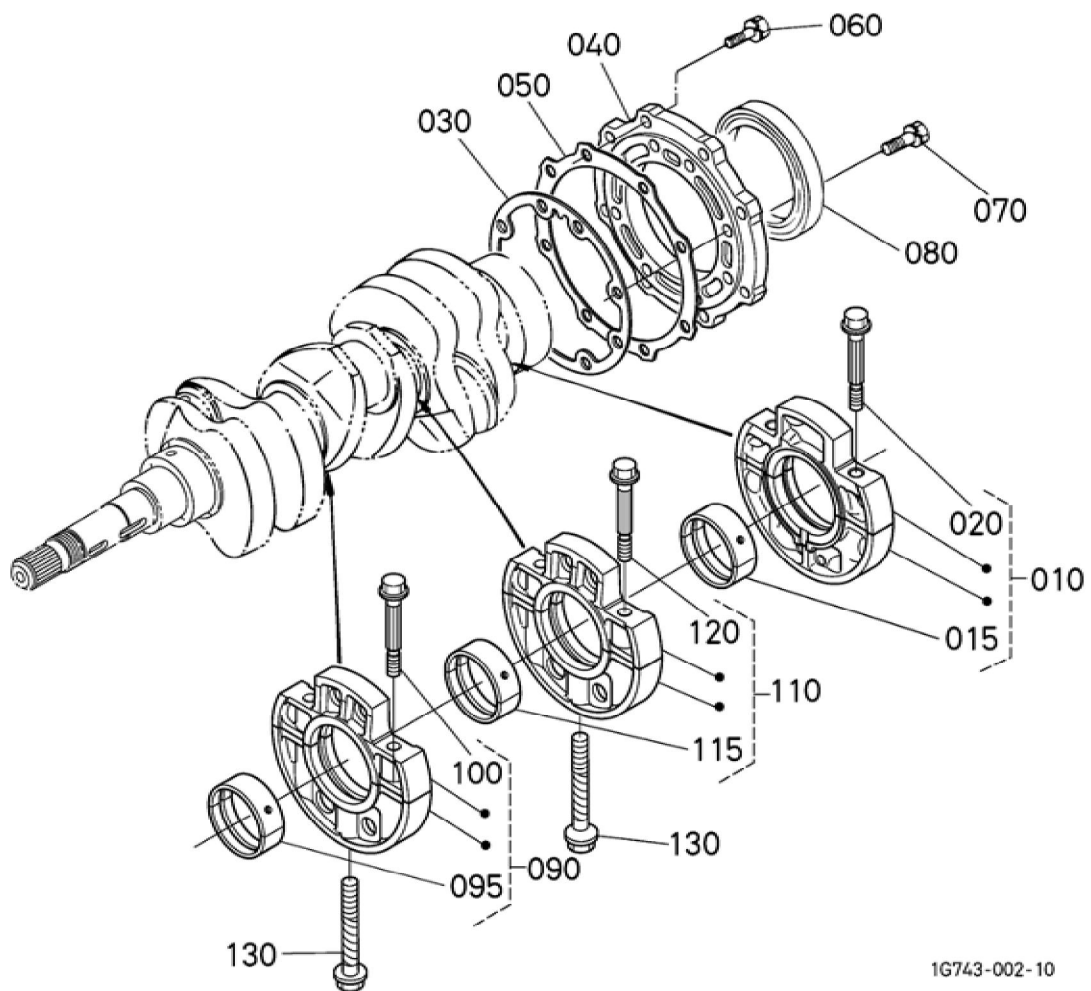





**Download the full PDF manual instantly.**

**Our customer service e-mail:**

**[aservicemanualpdf@yahoo.com](mailto:aservicemanualpdf@yahoo.com)**