

Update Date : 27-04-2020 Print Date : 07-04-2022

No.	Part Number	Part Name (POL)	Part Name (ENG)	QTY	IC	Serial No./PIN	Kg	Remarks
010	1C011-01019	KOMP.KURBELGEHAEUSE	COMP.CRANKCASE	1		<=3K1944	66.000	
010	1C011-01040	KOMP.KURBELGEHAEUSE	CRANKCASE, COMP	1	NI	>=3L0462	81.000	
010	1C011-01045	KOMP.KURBELGEHAEUSE	COMP.CRANKCASE	1	>>	>=6C0001	80.000	
020	15521-96020	STOPFEN	PLUG	2			0.003	
030	1C010-96010	STOPFEN	PLUG	1			0.012	
040	16683-96020	STOPFEN	PLUG	1			0.088	
050	15261-03370	STOEPSSEL, A BDICHTUNG	CAP, SEALING	4			0.005	
060	15221-03380	STOPFEN	CAP, SEALING	9			0.017	
070	15221-03390	STOPFEN	CAP, SEALING	1			0.030	
080	1C010-96160	STOPFEN	PLUG, EXPANSION	1			0.050	
090	05012-00820	ZYLINDERSTIFT	PIN, STRAIGHT	1			0.008	
100	05012-01016	ZYLINDERSTIFT	PIN STRAIGHT	2			0.010	
110	15221-33650	ROHRSTIFT	PIN, PIPE	2			0.004	
120	1C010-33640	STIFT	PIN, GEAR CASE	1			0.019	
130	1C010-04560	BOLZEN	BOLT, BEARING CASE	10			0.130	
150	1C040-33210	STIFT	PIPE, OIL	1			0.025	
150	1C040-33212	STIFT	PIPE, OIL	1	=		0.025	
180	1C010-37114	ADAPTER, WASSERROHR	JOINT, WATER PIPE	2			0.020	
200	1C011-01120	KURBELGEHAEUSE	CRANKCASE	1			52.000	
210	1C010-33650	STIFT	PIN, STRAIGHT (CASE, GEAR)	1			0.037	
215	1C010-33080	BLINDSTOPFEN	ASSY PLUG, O/FILLER	1			0.018	
220	E9151-33140	OELEINFUELLSTOPFEN	PLUG(OIL FILLER)	1			0.017	
230	04817-50300	O RING	O RING	1			0.001	

Update Date : 27-04-2020 Print Date : 07-04-2022

No.	Part Number	Part Name (POL)	Part Name (ENG)	QTY	IC	Serial No./PIN	Kg	Remarks
240	15602-33110	EINFUELLFLA NSCH	FLANGE,OIL FILLER	1			0.100	
250	15625-32890	DICHTUNGSP LATTE	GASKET	1			0.001	
260	01754-50820	SCHRAUBE	BOLT,FLANG E	2			0.015	
270	15451-96300	STOEPSEL,A BDICHTUNG	CAP,SEALING	1			0.002	

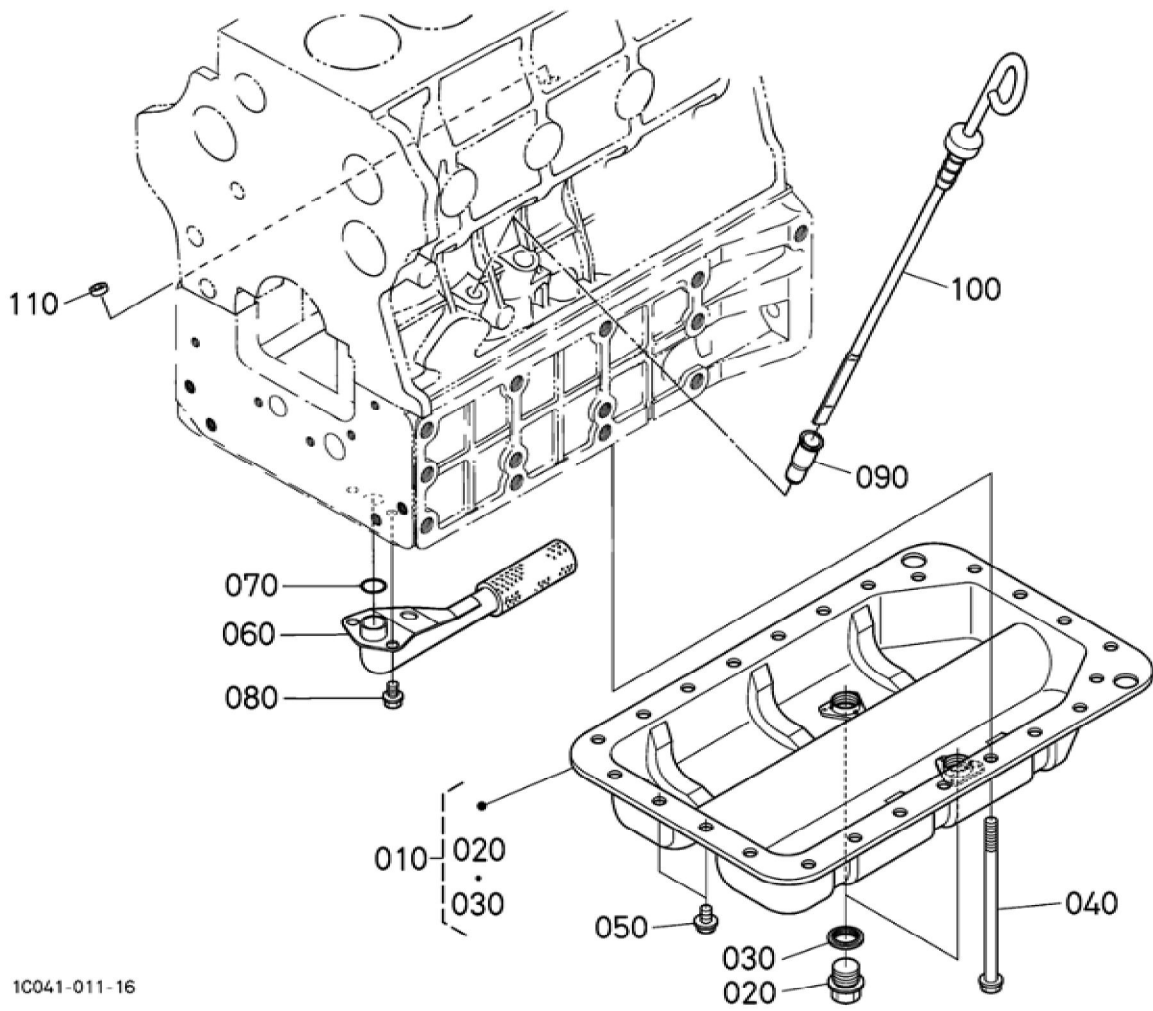

## BKIDK0567 &gt;&gt; ME9000DTHC &gt;&gt; MOTOR / ENGINE &gt;&gt; 000200 OL-FANGER / OIL PAN

Update Date : 27-04-2020 Print Date : 07-04-2022

No.	Part Number	Part Name (POL)	Part Name (ENG)	QTY	IC	Serial No./PIN	Kg	Remarks
010	1G511-01600	KOMP. OELWANNE	PAN,OIL,KIT	1		<=5U3796	0.000	
010	1G511-01605	KOMP. OELWANNE	PAN,OIL,KIT	1	>>	>=5W0001	2.430	
020	15707-33750	ENTLEERUN GSSTOPFEN	PLUG(DRAIN)	2			0.095	
030	15451-96670	DICHTUNG	PACKING	2		<=5U3796	0.003	
030	16265-96670	DICHTUNG	PACKING	2	>>	>=5W0001	0.010	
040	1C011-91010	BOLZEN	BOLT,FLANG E	20		<=6L3486	0.100	
040	1C011-91012	SCHRAUBE	BOLT,FLANG E	20	>>	>=6N0001	0.100	
050	01774-51014	SCHRAUBE	BOLT,FLANG E	6		<=3F1574	0.018	
050	1C010-91100	BOLZEN	BOLT,OILPAN	6	>>	>=3G0442	0.020	
060	1C011-32110	OELFILTER	FILTER(OIL)	1			0.280	
070	04814-00220	O RING	O RING	1			0.001	
080	01754-50814	SCHRAUBE	BOLT,FLANG E	2			0.012	
090	1C010-36422	FUEHRUNG, OELMESSST AB	GUIDE,OIL GAUGE	1			0.014	
100	1C010-36412	OELMESSST AB	GAUGE,OIL	1			0.040	
110	15451-96300	STOEPSEL,A BDICHTUNG	CAP,SEALING	1			0.002	

Update Date : 27-04-2020 Print Date : 07-04-2022

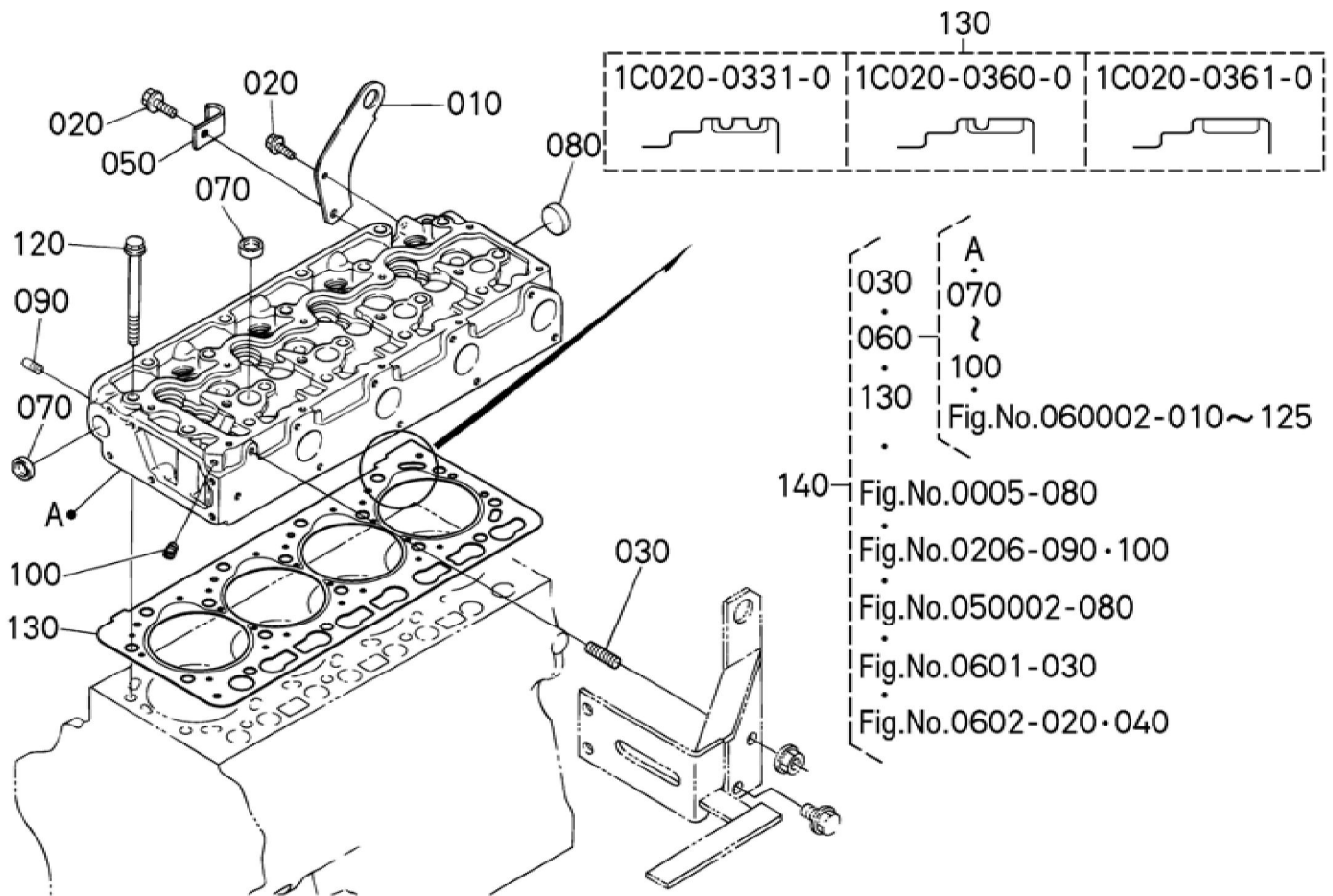

Update Date : 27-04-2020 Print Date : 07-04-2022

No.	Part Number	Part Name (POL)	Part Name (ENG)	QTY	IC	Serial No./PIN	Kg	Remarks
010	15471-01740	MOTORHAKEN	HOOK,ENGINE	1			0.180	
020	01754-50814	SCHRAUBE	BOLT,FLANGE	2			0.012	
030	15221-91530	STEBOLZEN	BOLT,STUD	1			0.011	
050	12234-67580	KABELKLEMME	CLAMP,CORD	1			0.012	
060	1C010-03023	GRP.ZYLINDERKOPF	HEAD,CYL,ASSY	1		<=3M1641	25.000	
060	1C010-03026	GRP.ZYLINDERKOPF	HEAD,CYL,ASSY	1	>>	>=3N0430	25.000	
070	15221-03370	STOPFEN	PLUG,CUP TYPE	5			0.010	
080	15221-03490	STOPFEN	CAP,SEALING	1			0.020	
090	15261-96010	STOPFEN	PLUG	4			0.002	
100	15521-96020	STOPFEN	PLUG	1			0.003	
120	1C010-03450	ZYLINDERKOPFSCHRAUBE	BOLT,CYLINDER HEAD	18			0.100	
130	1C020-03310	ZYLINDERKOPFDICHTUNG	GASKET,CYL. HEAD	1			0.240	STD/2 KERBEN
130	1C020-03600	ZYLINDERKOPFDICHTUNG	GASKET,CYL. HEAD	1			0.270	VERWENDUNG/1 KERBE
130	1C020-03610	ZYLINDERKOPFDICHTUNG	GASKET,CYL. HEAD	1			0.290	VERWENDUNG/KEINE KERBE
140	1C010-03004	GRP.ZYLINDERKOPF	HEAD,CYL,KIT	1		<=3M1641	26.500	OPTION
140	1C010-03006	GRP.ZYLINDERKOPF	KIT,CYLINDER HEAD	1	>>	>=3N0430	27.800	OPTION

Update Date : 27-04-2020 Print Date : 07-04-2022

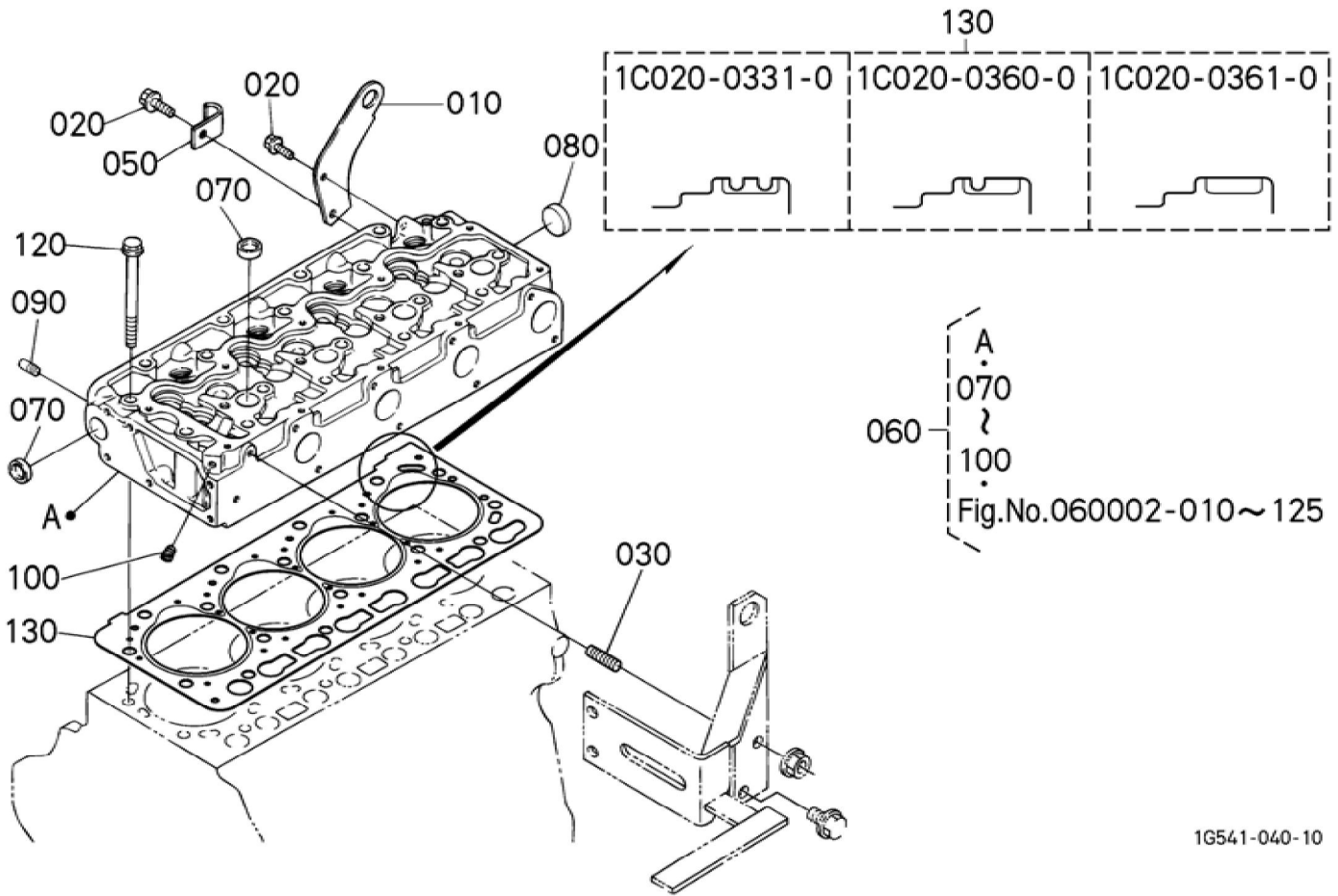



Update Date : 27-04-2020 Print Date : 07-04-2022

No.	Part Number	Part Name (POL)	Part Name (ENG)	QTY	IC	Serial No./PIN	Kg	Remarks
010	15471-01740	MOTORHAKEN	HOOK,ENGINE	1			0.180	
020	01754-50814	SCHRAUBE	BOLT,FLANGE	2			0.012	
030	15221-91530	STEBOLZEN	BOLT,STUD	1			0.011	
050	12234-67580	KABELKLEMME	CLAMP,CORD	1			0.012	
060	1G545-03020	GRP.ZYLINDERKOPF	ASSY CYLINDER HEAD	1			26.500	
070	15221-03370	STOPFEN	PLUG,CUP TYPE	5			0.010	
080	15221-03490	STOPFEN	CAP,SEALING	1			0.020	
090	15261-96010	STOPFEN	PLUG	4			0.002	
100	15521-96020	STOPFEN	PLUG	1			0.003	
120	1C010-03450	ZYLINDERKOPFSCHRAUBE	BOLT,CYLINDER HEAD	18			0.100	
130	1C020-03310	ZYLINDERKOPFDICHTUNG	GASKET,CYL. HEAD	1			0.240	STD/2 KERBEN
130	1C020-03600	ZYLINDERKOPFDICHTUNG	GASKET,CYL. HEAD	1			0.270	VERWENDUNG/1 KERBE
130	1C020-03610	ZYLINDERKOPFDICHTUNG	GASKET,CYL. HEAD	1			0.290	VERWENDUNG/KEINE KERBE

Update Date : 27-04-2020 Print Date : 07-04-2022

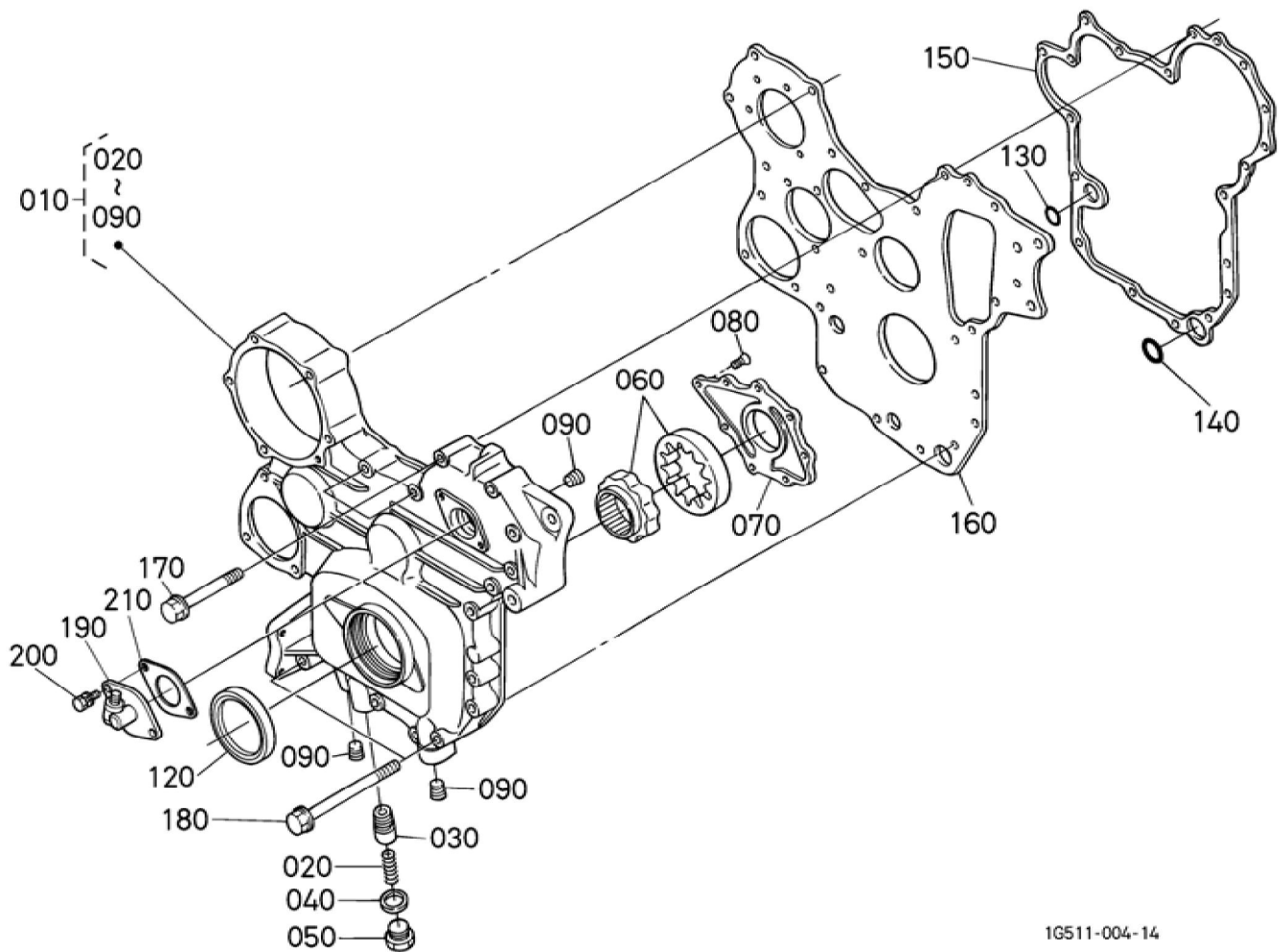

Update Date : 27-04-2020 Print Date : 07-04-2022

No.	Part Number	Part Name (POL)	Part Name (ENG)	QTY	IC	Serial No./PIN	Kg	Remarks
010	1G511-04014	GRP.GETRIE BEGEHAEUS E	ASSY CASE,GEAR	1		<=5S3289	5.150	
010	1G545-04010	GRP.GETRIE BEGEHAEUS E	ASSY CASE,GEAR	1	>>	>=5U0001	5.050	
020	1C010-36950	FEDER	SPRING	1			0.014	
030	1C010-36922	UEBERLAUFV ENTIL	VALVE,RELIE F	1			0.031	
040	15451-96670	DICHTUNG	PACKING	1			0.003	
050	1C010-36960	STOPFEN	PLUG	1			0.050	
060	1C010-35070	STIFT	ROTOR,ASSY (OIL PUMP)	1			0.300	
070	1C010-35130	DECKEL, OELPUMPE	COVER,OIL PUMP	1			0.130	
080	03016-50616	SCHRAUBE	SCREW,FLAT HEAD (PHILLIPS)	8			0.003	
090	1C010-96020	STOPFEN	PLUG	3			0.022	
120	1C020-04140	OELDICHTUN GSRING	SEAL,OIL	1			0.044	
130	04814-00200	O RING	O RING	1			0.010	
140	04814-00240	O RING	O RING	1			0.001	
160	1C010-04162	PLATTE	PLATE,GEAR CASE	1			4.100	
170	01754-50855	SCHRAUBE	BOLT,FLANG E	13		<=6Q3227	0.020	
170	1C010-91030	SCHRAUBE	BOLT,FLANG E	13	>>	>=6S0001	0.028	
180	01754-50875	SCHRAUBE	BOLT,FLANG E	2		<=6Q3227	0.030	
180	1C010-91040	SCHRAUBE	BOLT,FLANG E	2	>>	>=6S0001	0.035	
190	58417-25950	GRP.GETRIE BEGEHAEUS E	ASSY GEAR CASE,H/M	1			0.290	
200	1C011-91020	BOLZEN	BOLT	2			0.008	

Update Date : 27-04-2020 Print Date : 07-04-2022

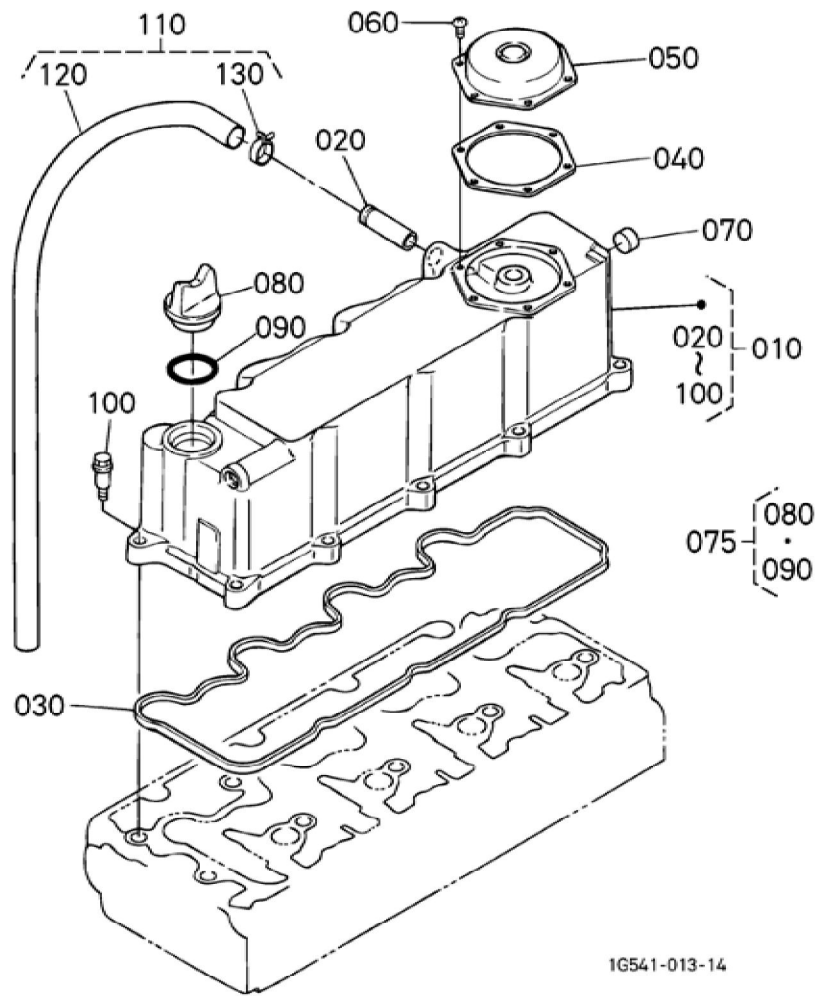



**Download the full PDF manual instantly.**

**Our customer service e-mail:**

**[aservicemanualpdf@yahoo.com](mailto:aservicemanualpdf@yahoo.com)**