

Update Date : 2019/12/12 Print Date : 2022/03/28

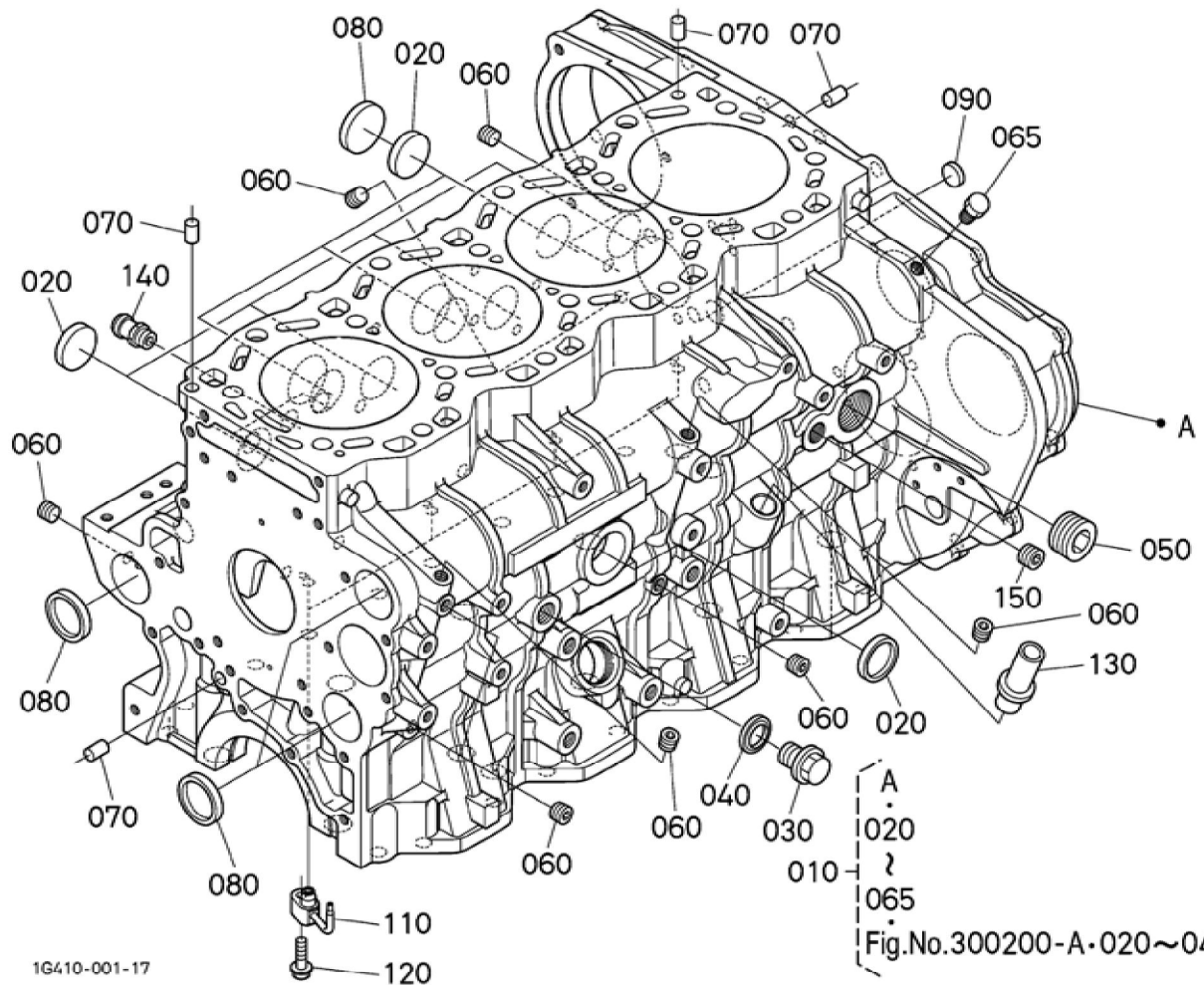

BKIDK5010 >> M130XDTC >> MOTOR / ENGINE >> 300100 KURBELGEHAEUSE (OBEN) / CRANKCASE (UPPER)

Update Date : 2019/12/12 Print Date : 2022/03/28

No.	Part Number	Part Name (POL)	Part Name (ENG)	QTY	IC	Serial No./PIN	Kg	Remarks
010	1G410-01024	GRP. KURBELGEH AEUSE	ASSY CRANKCASE	1		<=BJ0188	175.000	
010	1G410-01027	GRP. KURBELGEH AEUSE	CRANKCASE, ASSY	1	>>	>=BL0001	175.000	BITTE BESTELLEN SIE POS.010 UND 150 NEUE TEILE.
010	1G410-01030	GRP. KURBELGEH AEUSE	CRANKCASE, ASSY	1	NI	>=3EL0001	176.000	
010	1G410-01033	GRP. KURBELGEH AEUSE	CRANKCASE, ASSY	1	>>	>=3FL0001	176.000	
010	1G410-01034	GRP. KURBELGEH AEUSE	CRANKCASE, ASSY	1	>>	>=3GA0001	176.000	
020	15221-03490	STOPFEN	CAP,SEALING	8			0.020	
030	06311-55030	STOPFEN	PLUG	1			0.050	
040	04724-00170	DICHTUNGSP LATTE	GASKET	1			0.005	
050	16683-96020	STOPFEN	PLUG	1			0.088	
060	15521-96020	STOPFEN	PLUG	9		<=3FKZ999	0.003	
060	15521-96020	STOPFEN	PLUG	8		>=3FL0001	0.003	
065	1J527-96020	STECKER	PLUG(R1/8)	1		>=3FL0001	0.013	
070	05012-01016	ZYLINDERSTI FT	PIN STRAIGHT	4			0.010	
080	15451-96280	STOEPSSEL,A BDICHTUNG	CAP,SEALING	6			0.026	
090	16851-96270	KAPPE	CAP,SEALING	1			0.005	
110	1G410-01570	DUESE	JET(OIL)	4			0.025	
120	01754-50620	SCHRAUBE	BOLT,FLANG E	4			0.007	
130	1C040-33212	STIFT	PIPE,OIL	1			0.025	
140	1C010-37114	ADAPTER, WASSERROH R	JOINT,WATE R PIPE	3			0.020	
150	16241-96020	STOPFEN	PLUG	1		>=3EL0001	0.015	

Update Date : 2019/12/12 Print Date : 2022/03/28

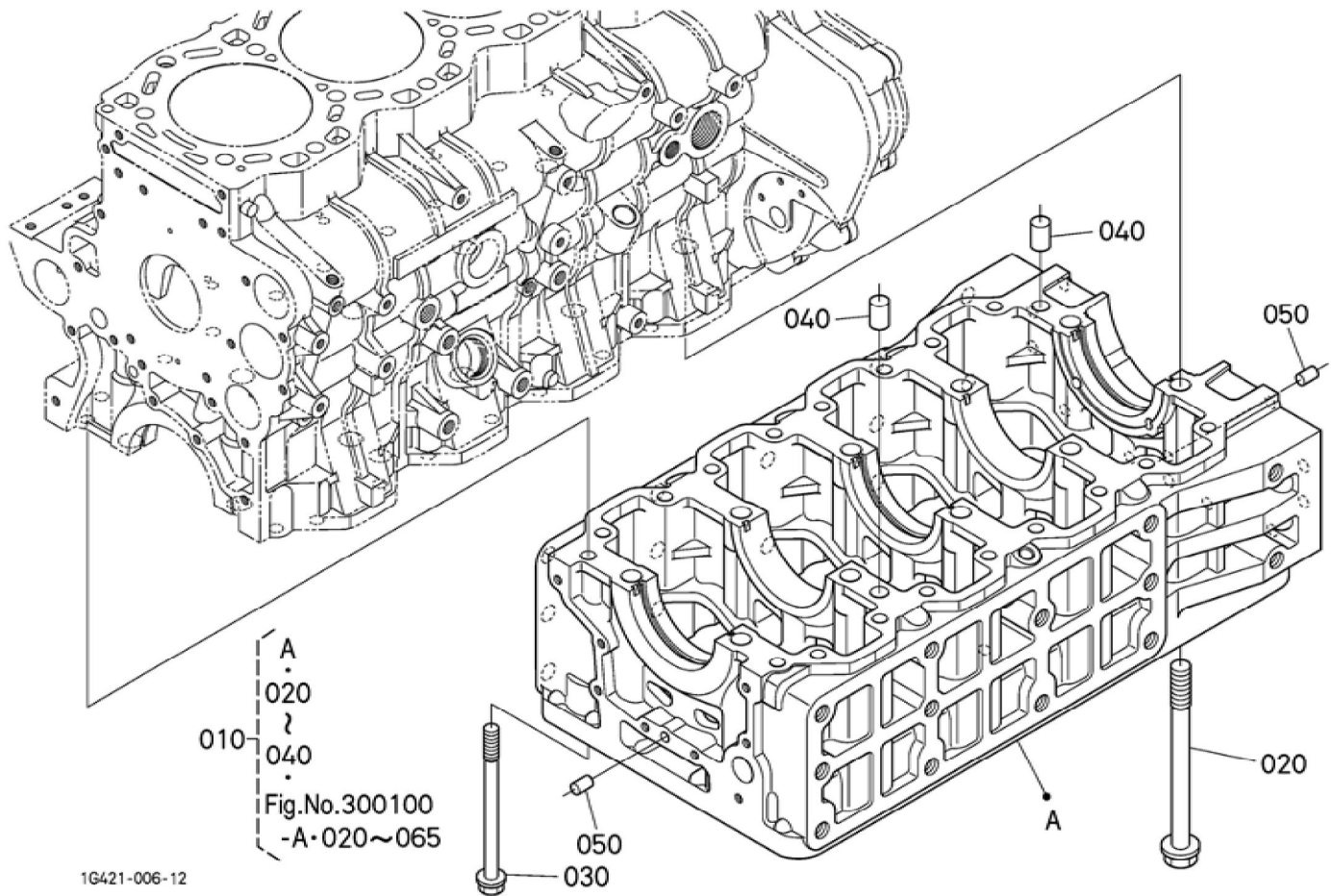

1G421-006-12

Update Date : 2019/12/12 Print Date : 2022/03/28

No.	Part Number	Part Name (POL)	Part Name (ENG)	QTY	IC	Serial No./PIN	Kg	Remarks
010	1G410-01024	GRP. KURBELGEH AEUSE	ASSY CRANKCASE	1		<=BJ0188	175.000	
010	1G410-01027	GRP. KURBELGEH AEUSE	CRANKCASE, ASSY	1	>>	>=BL0001	175.000	SEE NOTE
010	1G410-01030	GRP. KURBELGEH AEUSE	CRANKCASE, ASSY	1	NI	>=3EL0001	176.000	
010	1G410-01033	GRP. KURBELGEH AEUSE	CRANKCASE, ASSY	1	>>	>=3FL0001	176.000	
010	1G410-01034	GRP. KURBELGEH AEUSE	CRANKCASE, ASSY	1	>>	>=3GA0001	176.000	
020	1G410-99000	BOLZEN	BOLT	10			0.296	
030	1G410-91010	BOLZEN	BOLT	18			0.133	
040	1C011-94510	ZYLINDERSTI FT	PIN,STRAIGH T	2			0.040	
050	05012-01016	ZYLINDERSTI FT	PIN STRAIGHT	2			0.010	

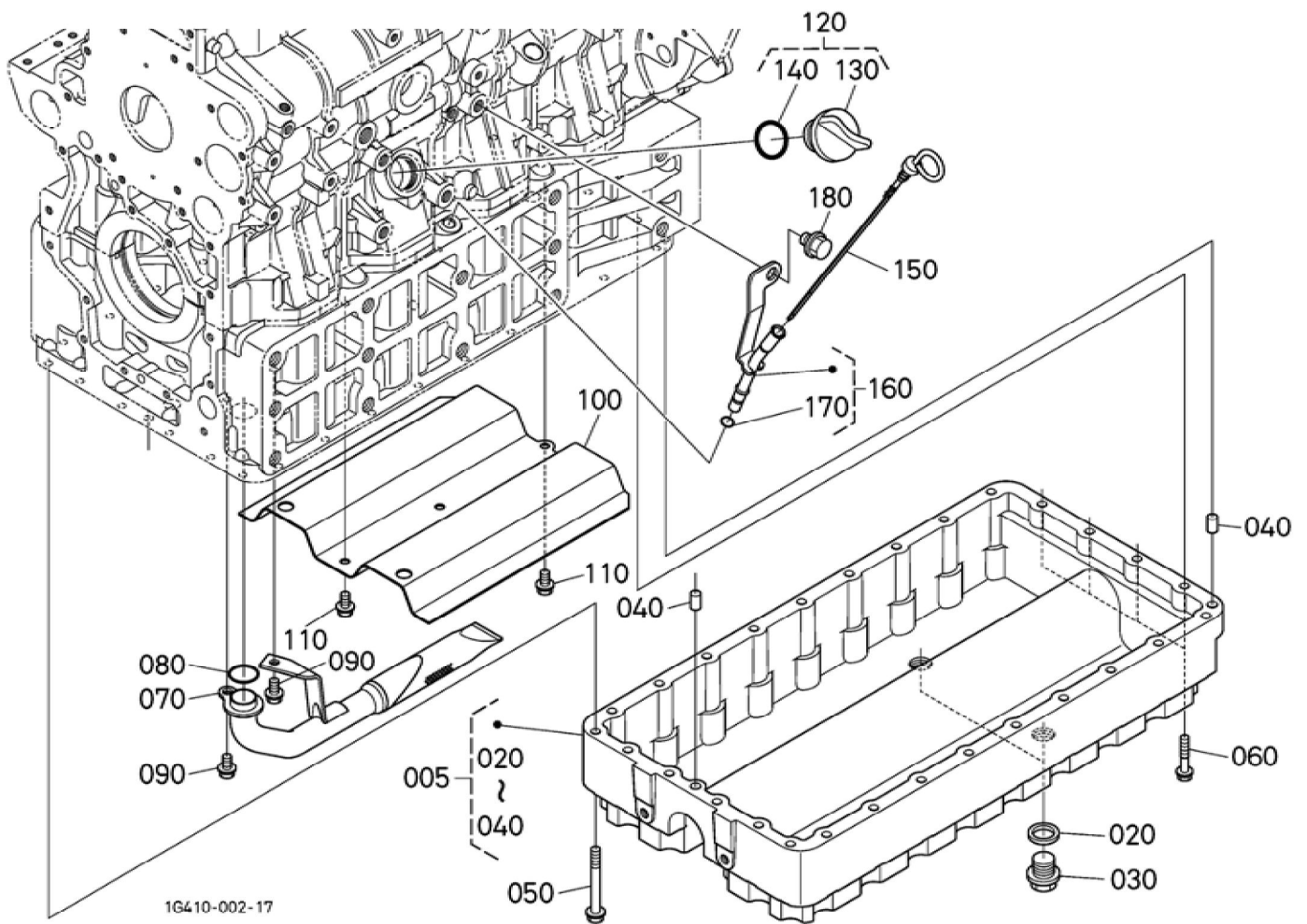

BKIDK5010 >> M130XDTC >> MOTOR / ENGINE >> 301000 OELWANNE / OIL PAN

Update Date : 2019/12/12 Print Date : 2022/03/28

No.	Part Number	Part Name (POL)	Part Name (ENG)	QTY	IC	Serial No./PIN	Kg	Remarks
005	1G410-01590	OELWANNE,K OMP.	PAN,OIL,ASS Y	1		>=3FU0001	25.000	
020	15451-96670	DICHTUNG	PACKING	2			0.003	
030	15707-33750	ENTLEERUN GSSTOPFEN	PLUG(DRAIN)	2			0.095	
040	05012-01016	ZYLINDERSTI FT	PIN STRAIGHT	2			0.010	
050	1G772-91010	BOLZEN	BOLT,FLANG E	24			0.030	
060	1G410-91022	BOLZEN	BOLT,FLANG E	4			0.018	
070	1G410-32110	OELFILTER	FILTER,OIL	1			0.330	
080	04814-05250	O RING	O RING	1			0.001	
090	01754-50812	SCHRAUBE	BOLT,FLANG E	2			0.008	
100	1G410-01670	STAUBLECH	PLATE,BAFFL E	1		<=3FBZ999	0.820	
100	1G410-01673	STAUBLECH	PLATE,BAFFL E	1	>>	>=3FC0001	0.820	
110	01754-50812	SCHRAUBE	BOLT,FLANG E	3			0.008	
120	1C010-33080	BLINDSTOPF EN	ASSY PLUG,O/FILL ER	1			0.018	
130	E9151-33140	OELEINFUEL LSTOPFEN	PLUG(OIL FILLER)	1			0.017	
140	04817-50300	O RING	O RING	1			0.001	
150	1G410-36413	OELMESSST AB	GAUGE,OIL	1			0.028	
160	1G410-36500	GRP.FUEHRU NG	GUIDE,ASSY (OIL GAUGE)	1			0.102	
170	04814-00090	O RING	O RING	1			0.001	
180	01774-51212	SCHRAUBE	BOLT,FLANG E	1			0.028	

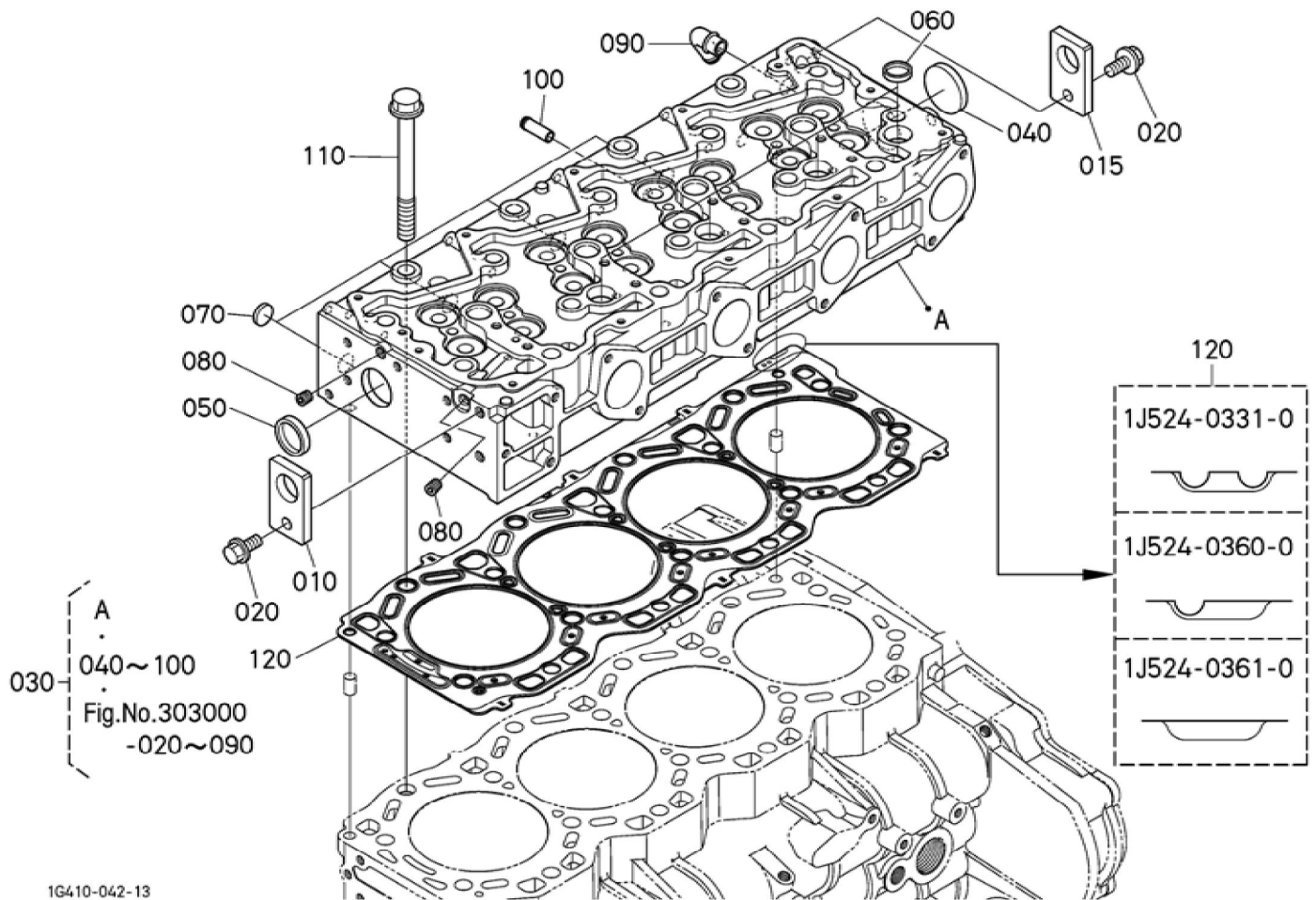

BKIDK5010 >> M130XDTC >> MOTOR / ENGINE >> 302000 ZYLINDERKOPF / CYLINDER HEAD

Update Date : 2019/12/12 Print Date : 2022/03/28

No.	Part Number	Part Name (POL)	Part Name (ENG)	QTY	IC	Serial No./PIN	Kg	Remarks
010	1G410-01743	MOTOR-ANKERHAKE N	HOOK,ENGINE	1			0.148	
015	1G410-01743	MOTOR-ANKERHAKE N	HOOK,ENGINE	1			0.148	
020	01774-51020	SCHRAUBE	BOLT,FLANGE	2			0.020	
030	1G410-03020	GRP.ZYLINDERKOPF	ASSY CYLINDER HEAD	1			39.000	
040	15221-03390	STOPFEN	CAP,SEALING	1			0.030	
050	15221-03490	STOPFEN	CAP,SEALING	1			0.020	
060	15221-03370	STOPFEN	PLUG,CUP TYPE	4			0.010	
070	15261-03370	STOEPSEL,ABDICHTUNG	CAP,SEALING	4			0.005	
080	15521-96020	STOPFEN	PLUG	2			0.003	
090	1G777-05550	ROHRSCHALTUNG	JOINT,BREATHER	1			0.025	
100	16241-73370	ROHR	PIPE,WATER RETURN	1			0.007	
110	1G410-03450	ZYLINDERKOPFSCHRAUBE	BOLT,CYLINDER HEAD	18		<=3FBZ999	0.165	
110	1J524-03450	ZYLINDERKOPFSCHRAUBE	BOLT (CYLINDER HEAD)	18	NI	>=3FC0001	0.160	
120	1G410-03310	ZYLINDERKOPFDICHTUNG	GASKET,CYLINDER HEAD	1		<=3FBZ999	0.255	STD
120	1J524-03310	ZYLINDERKOPFDICHTUNG	GASKET (CYLINDER HEAD)	1	NI	>=3FC0001	0.360	STD
120	1G410-03600	ZYLINDERKOPFDICHTUNG	GASKET,CYLINDER HEAD	1		<=3FBZ999	0.300	VERWENDUNG
120	1J524-03600	ZYLINDERKOPFDICHTUNG	GASKET (CYLINDER HEAD)	1	NI	>=3FC0001	0.400	EIGNUNG
120	1G410-03610	ZYLINDERKOPFDICHTUNG	GASKET,CYLINDER HEAD	1		<=3FBZ999	0.320	VERWENDUNG
120	1J524-03610	ZYLINDERKOPFDICHTUNG	GASKET (CYLINDER HEAD)	1	NI	>=3FC0001	0.450	EIGNUNG

Update Date : 2019/12/12 Print Date : 2022/03/28

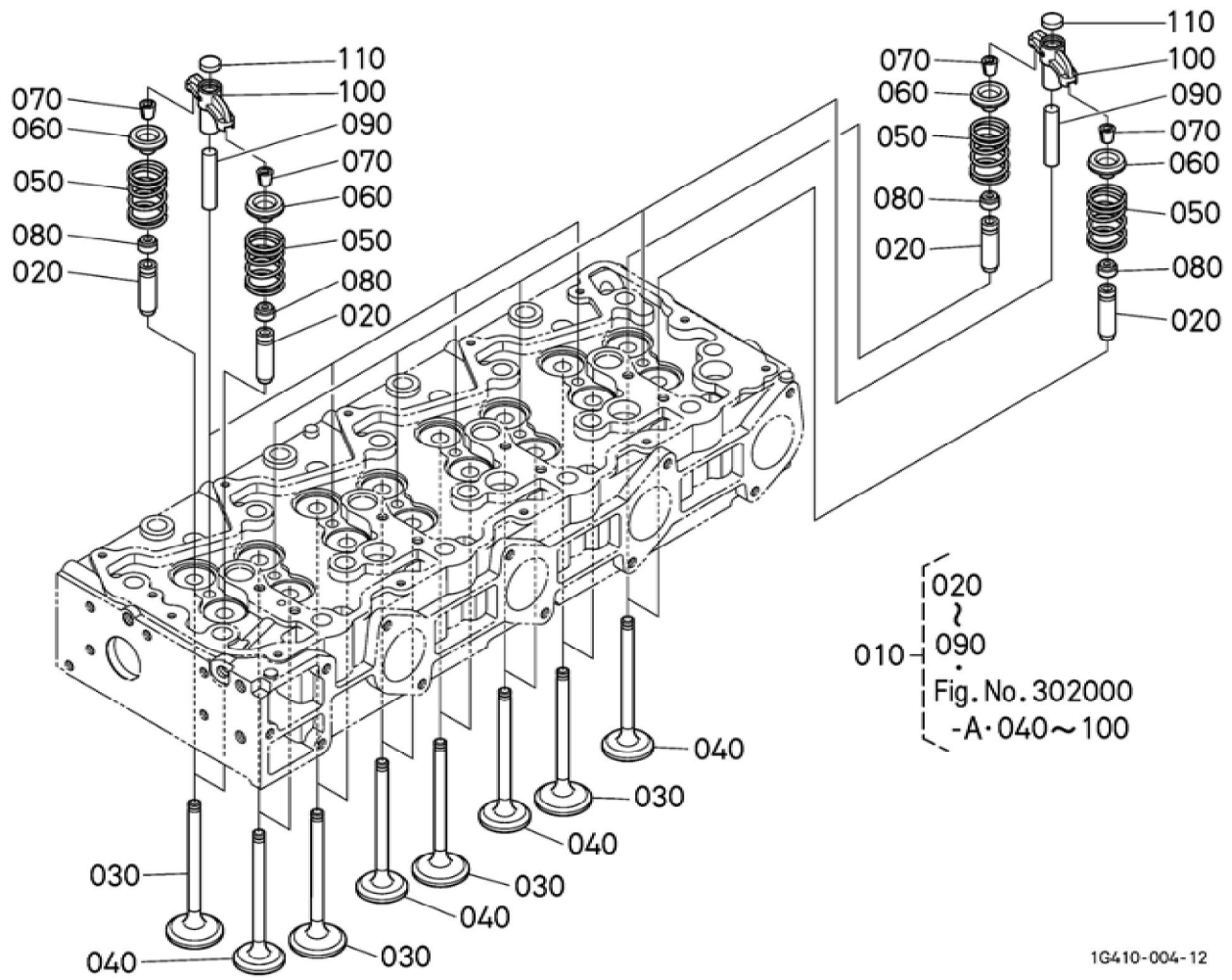

Update Date : 2019/12/12 Print Date : 2022/03/28

No.	Part Number	Part Name (POL)	Part Name (ENG)	QTY	IC	Serial No./PIN	Kg	Remarks
010	1G410-03020	GRP.ZYLINDERKOPF	ASSY CYLINDER HEAD	1			39.000	
020	1C010-13560	AUSLASSVENTILFUEHRUNG	GUIDE,EXHAUST VALVE	16			0.025	
030	1G410-13110	EINLASSVENTIL	VALVE,INLET	8			0.095	
040	1G410-13120	AUSLASSVENTIL	VALVE,EXHAUST	8			0.085	
050	15221-13240	VENTILFEDER	SPRING,VALVE	16			0.036	
060	15221-13330	HALTER	RETAINER,VALVE SP.	16			0.028	
070	15221-13980	KLEMMSCHEIBE	COLLET,VALVE SPRING	16			0.005	SET
080	15221-13153	VENTILDICHTUNG	SEAL(VALVE STEM)	16			0.002	
090	1C010-13482	VENTILFUEHRUNG	SHAFT,VALVE BURIGE	8			0.020	
100	1G410-13470	HUBARM, VENTIL	ARM,VALVE BRIGE	8			0.066	
110	1C010-13490	PUFFER	PAD	8			0.003	

Update Date : 2019/12/12 Print Date : 2022/03/28

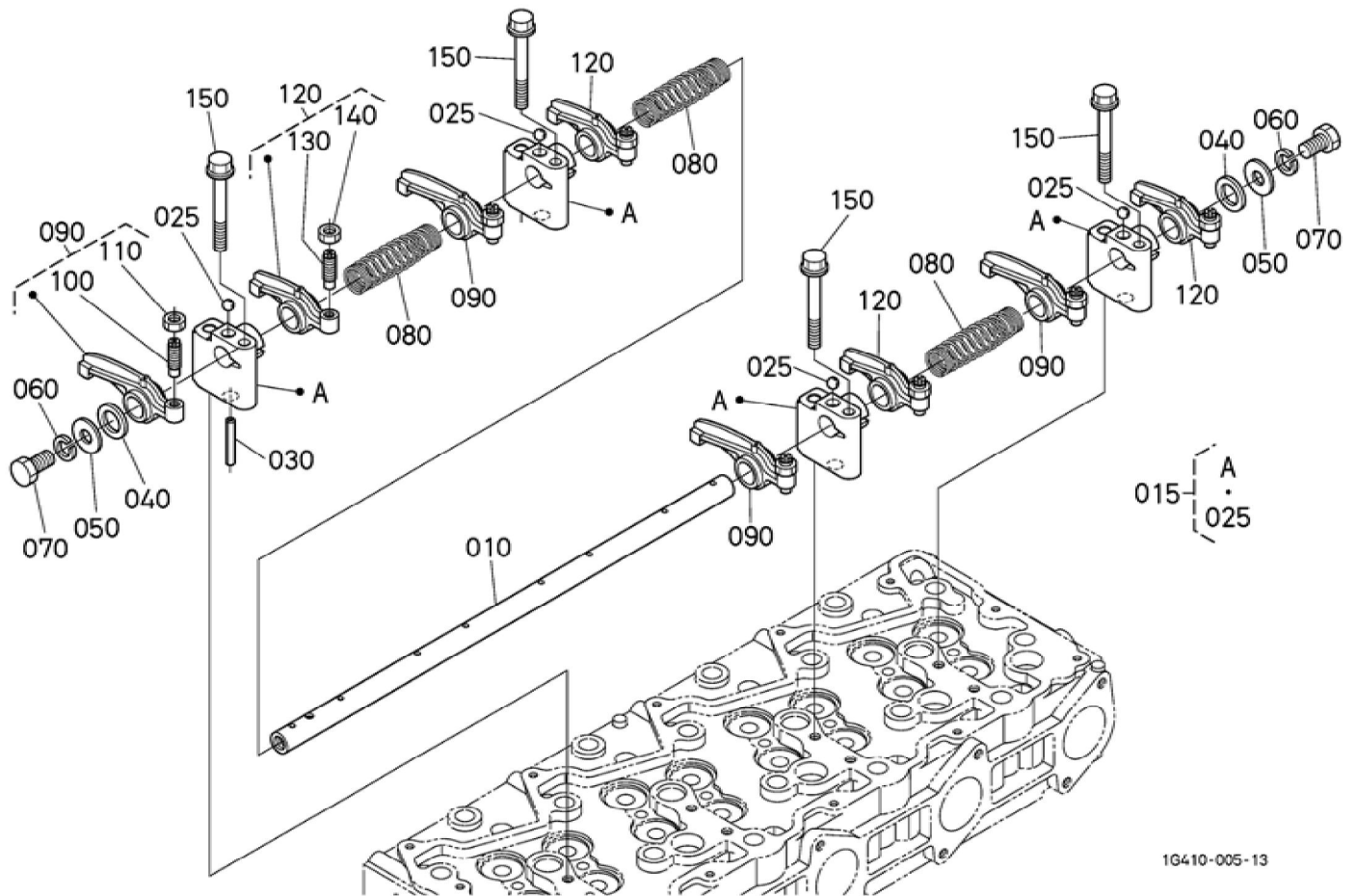



Download the full PDF manual instantly.

Our customer service e-mail:

aservicemanualpdf@yahoo.com