

## BKIDK5107 &gt;&gt; M110GXDT-2 &gt;&gt; MOTOR / ENGINE &gt;&gt; 300000 KURBELGEHAEUSE / CRANKCASE

Update Date : 2020/05/07 Print Date : 2022/03/16

No.	Part Number	Part Name (POL)	Part Name (ENG)	QTY	IC	Serial No./PIN	Kg	Remarks
010	1J540-01010	KOMP.KURBELGEHAEUSE	CRANKCASE, COMP	1		<=2GPZ999	84.000	
010	1J540-01012	KURBELGEHAEUSE,KOMP.	CRANKCASE, COMP	1	>>	>=2GQ0001	72.000	
020	15521-96020	STOPFEN	PLUG	3			0.003	
025	15841-96020	STOPFEN	PLUG	2			0.020	
030	1C010-96010	STOPFEN	PLUG	1			0.012	
040	16683-96020	STOPFEN	PLUG	1			0.088	
050	15261-03370	STOEPSEL,ABDICHTUNG	CAP,SEALING	4			0.005	
060	15221-03380	STOPFEN	CAP,SEALING	6		<=2GPZ999	0.017	
060	1J550-03380	STOEPSEL,ABDICHTUNG	PLUG,CUP TYPE	6	>>	>=2GQ0001	0.017	
065	15221-03380	STOPFEN	CAP,SEALING	2			0.017	
070	15221-03390	STOPFEN	CAP,SEALING	1			0.030	
080	1C010-96160	STOPFEN	PLUG,EXPANSION	1			0.050	
090	05012-00820	ZYLINDERSTIFT	PIN,STRAIGHT	1			0.008	
100	05012-01016	ZYLINDERSTIFT	PIN STRAIGHT	2			0.010	
110	15221-33650	ROHRSTIFT	PIN,PIPE	2			0.004	
120	1C010-33643	STIFT	PIN,STRAIGHT	1			0.019	
130	1C010-04560	BOLZEN	BOLT,BEARING CASE	10			0.130	
140	1C040-33212	STIFT	PIPE,OIL	1			0.025	
150	1J550-71352	ROHRSCHALTUNG	JOINT,PIPE	1			0.100	
160	1C010-37114	ADAPTER,WASSERROHR	JOINT,WATER PIPE	1			0.020	
170	06311-55030	STOPFEN	PLUG	1			0.050	
180	04724-00170	DICHTUNGSPLATTE	GASKET	1			0.005	
190	1C012-01124	KURBELGEHAEUSE	CRANKCASE	1			44.050	
200	1C010-33653	STIFT	PIN,STRAIGHT	1			0.037	

## BKIDK5107 &gt;&gt; M110GXDT-2 &gt;&gt; MOTOR / ENGINE &gt;&gt; 300000 KURBELGEHAEUSE / CRANKCASE

Update Date : 2020/05/07 Print Date : 2022/03/16

No.	Part Number	Part Name (POL)	Part Name (ENG)	QTY	IC	Serial No./PIN	Kg	Remarks
205	1C011-94510	ZYLINDERSTIFT	PIN, STRAIGHT	2			0.040	
210	1C010-33080	BLINDSTOPFEN	ASSY PLUG, O/FILLER	1			0.018	
220	E9151-33140	OELEINFUELLSTOPFEN	PLUG(OIL FILLER)	1			0.017	
230	04817-50300	O RING	O RING	1			0.001	
240	15602-33110	EINFUELLFLANSCH	FLANGE, OIL FILLER	1			0.100	
250	15625-32890	DICHTUNGSPLATTE	GASKET	1			0.001	
260	01754-50820	SCHRAUBE	BOLT, FLANGE	2			0.015	
270	1C011-91012	SCHRAUBE	BOLT, FLANGE	2			0.100	
280	31220-14290	STOPFEN	PLUG	2			0.002	

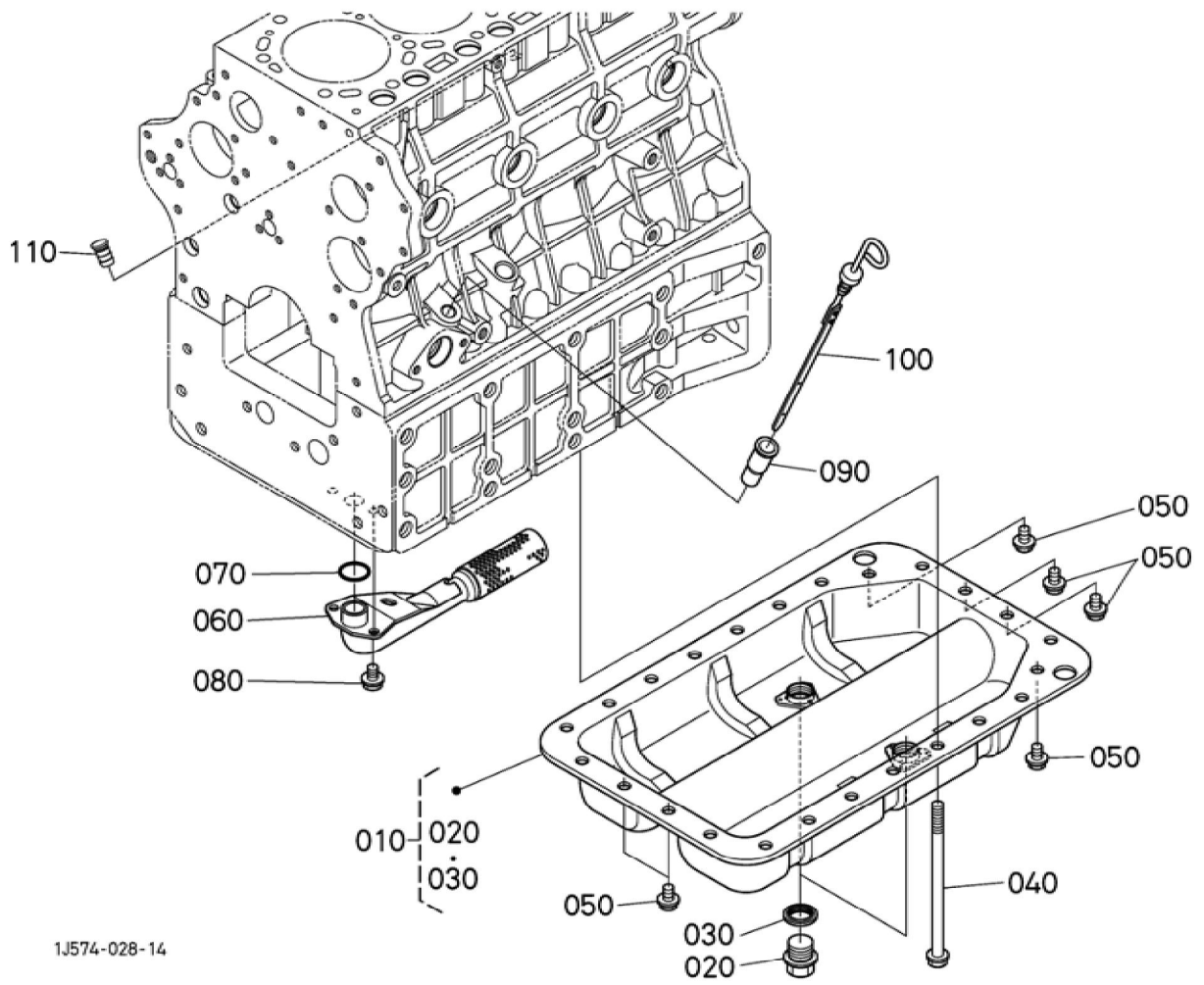

## BKIDK5107 &gt;&gt; M110GXDTTC-2 &gt;&gt; MOTOR / ENGINE &gt;&gt; 301000 OELWANNE / OIL PAN

Update Date : 2020/05/07 Print Date : 2022/03/16

No.	Part Number	Part Name (POL)	Part Name (ENG)	QTY	IC	Serial No./PIN	Kg	Remarks
010	1G511-01605	KOMP. OELWANNE	PAN,OIL,KIT	1			2.430	
020	15707-33750	ENTLEERUN GSSTOPFEN	PLUG(DRAIN)	2			0.095	
030	16265-96670	DICHTUNG	PACKING	2			0.010	
040	1C011-91012	SCHRAUBE	BOLT,FLANG E	18			0.100	
050	1C010-91100	BOLZEN	BOLT,OILPAN	6			0.020	
060	1C011-32110	OELFILTER	FILTER(OIL)	1		<=2LFZ999	0.280	
060	1C011-32115	OELFILTER	FILTER(OIL)	1	>>	>=2LG0001	0.280	
070	04814-00220	O RING	O RING	1			0.001	
080	01754-50812	SCHRAUBE	BOLT,FLANG E	2			0.008	
090	1C010-36422	FUEHRUNG, OELMESSST AB	GUIDE,OIL GAUGE	1			0.014	
100	1C042-36410	OELMESSST AB	GAUGE,OIL	1			0.030	
110	1G513-36550	STOPFEN, OELMESSST AB	PLUG,OIL GAUGE	1			0.004	

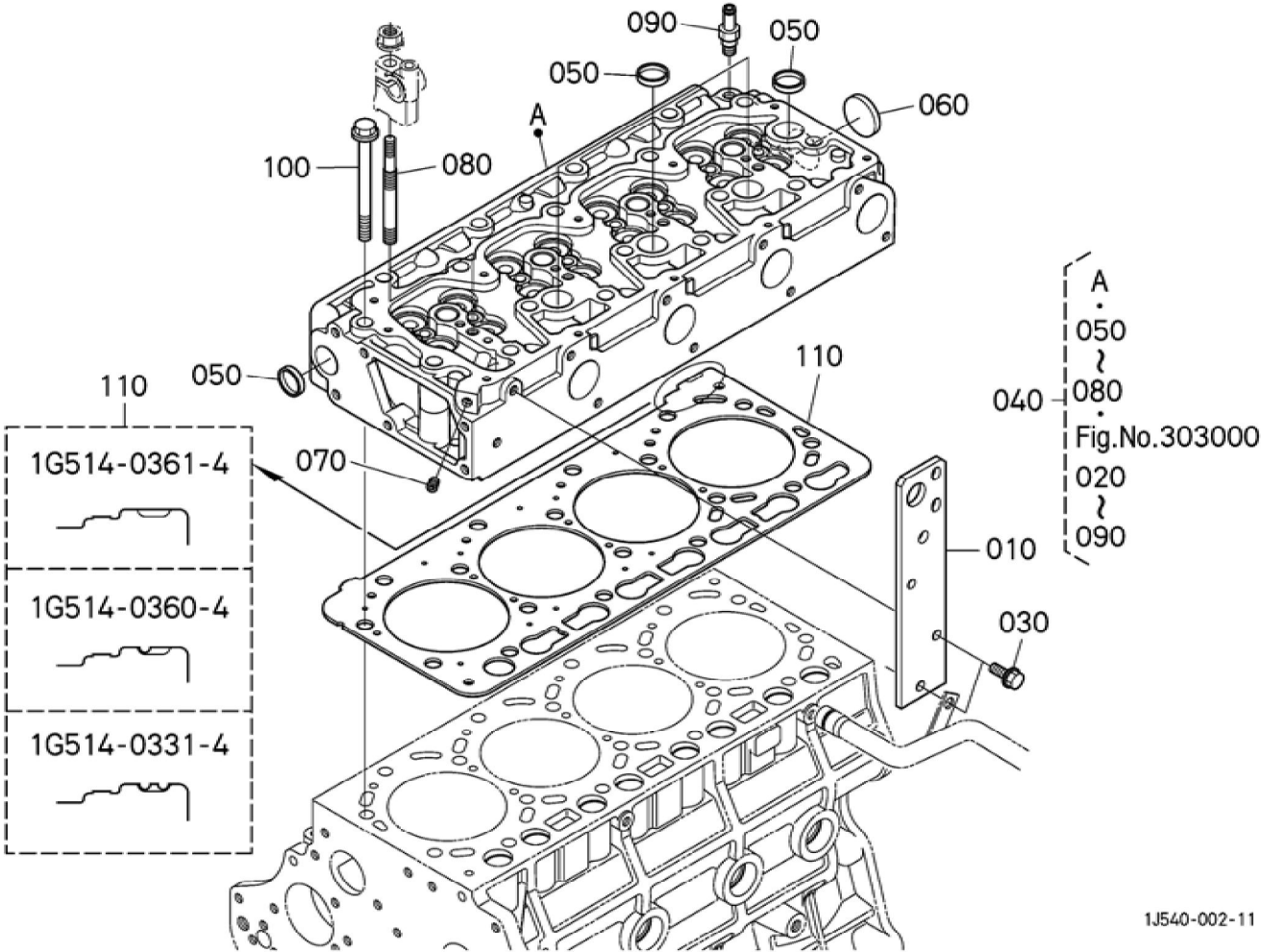

## BKIDK5107 &gt;&gt; M110GXDTC-2 &gt;&gt; MOTOR / ENGINE &gt;&gt; 302000 ZYLINDERKOPF / CYLINDER HEAD

Update Date : 2020/05/07 Print Date : 2022/03/16

No.	Part Number	Part Name (POL)	Part Name (ENG)	QTY	IC	Serial No./PIN	Kg	Remarks
010	3Y205-12602	HALTER	BRACKET,FRONT	1			0.460	
030	1J500-91020	SCHRAUBE	BOLT,FLANGE	2			0.012	
040	1J574-03026	GRP.ZYLINDERKOPF	ASSY CYLINDER HEAD	1			26.000	
050	15221-03370	STOPFEN	PLUG,CUP TYPE	5			0.010	
060	15221-03490	STOPFEN	CAP,SEALING	1			0.020	
070	15521-96020	STOPFEN	PLUG	1			0.003	
080	1J574-03410	STEBOLZEN	STUD	4			0.050	
090	1J500-17610	ROHRVERBINDUNG	JOINT,PIPE (WATER)	1			0.025	
100	1C010-03450	ZYLINDERKOPFSCHRAUBE	BOLT,CYLINDER HEAD	18			0.100	
110	1G514-03314	ZYLINDERKOPFDICHTUNG	GASKET,CYL. HEAD	1			0.230	STD/ 2 KERBEN
110	1G514-03604	ZYLINDERKOPFDICHTUNG	GASKET,CYL. HEAD	1			0.260	VERWENDUNG / 1 KERBE
110	1G514-03614	ZYLINDERKOPFDICHTUNG	GASKET,CYL. HEAD	1			0.270	VERWENDUNG / KEINE KERBE

Update Date : 2020/05/07 Print Date : 2022/03/16

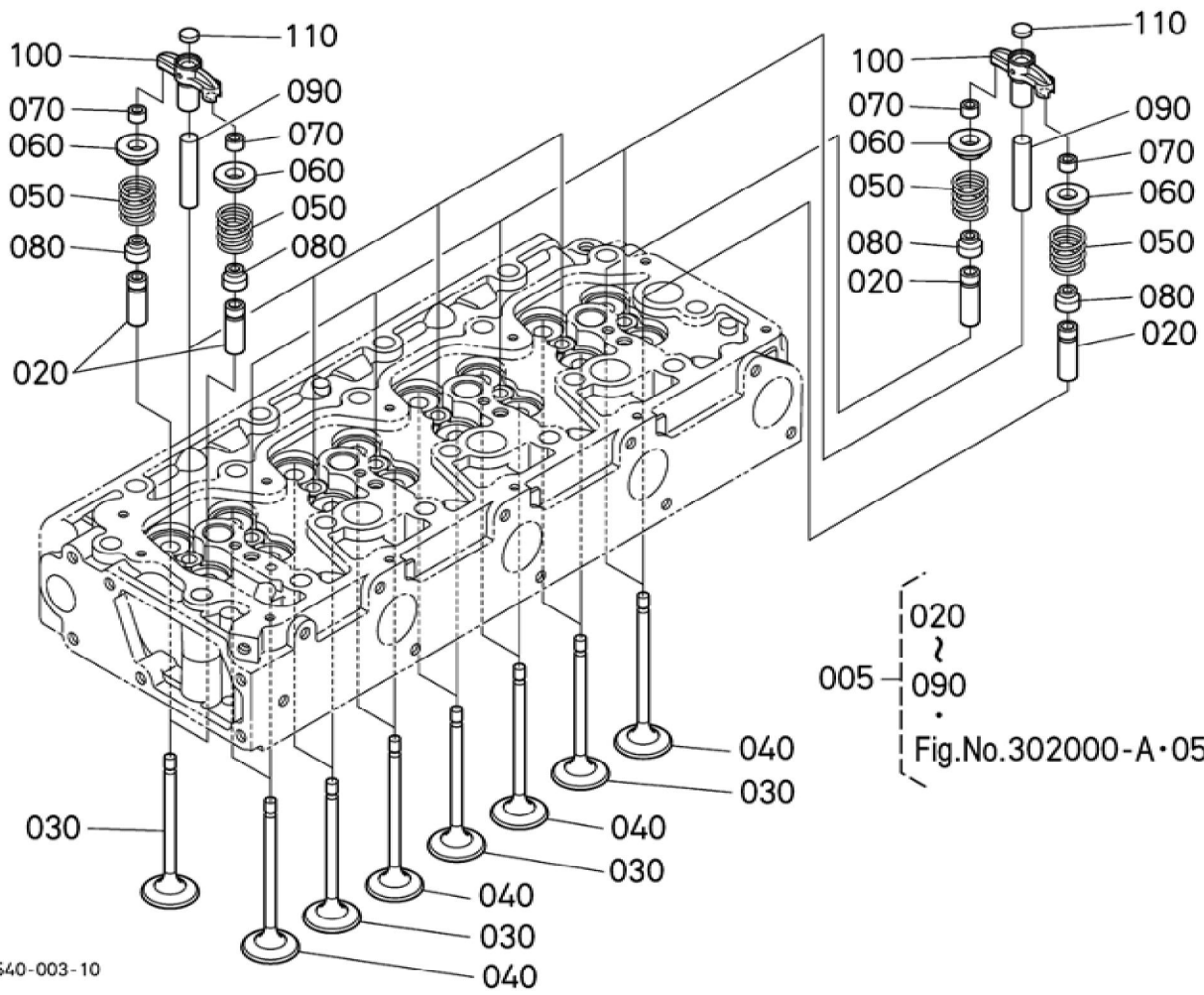

1J540-003-10



Update Date : 2020/05/07 Print Date : 2022/03/16

No.	Part Number	Part Name (POL)	Part Name (ENG)	QTY	IC	Serial No./PIN	Kg	Remarks
005	1J574-03026	GRP.ZYLINDERKOPF	ASSY CYLINDER HEAD	1			26.000	
020	16261-13560	AUSLASSVENTILFUEHRUNG	GUIDE, EXHAUST VALVE	16			0.019	
030	1C020-13112	EINLASSVENTIL	VALVE, INLET	8		<=2HHZ999	0.050	
030	1C020-13113	EINLASSVENTIL	VALVE, INLET	8	>>	>=2HJ0001	0.050	
040	1C020-13122	AUSLASSVENTIL	VALVE, EXHAUST	8		<=2HHZ999	0.050	
040	1C020-13123	AUSLASSVENTIL	VALVE, EXHAUST	8	>>	>=2HJ0001	0.050	
050	1C010-13240	VENTILFEDER	SPRING, VALVE	16			0.020	
060	16261-13330	HALTER, VENTILFEDER	RETAINER, VALVE SP.	16			0.015	
070	15261-13980	KLEMMSCHEIBE	COLLET (VALVE SPRING)	16			0.002	SET
080	1C010-13150	VENTILDICHTUNG	SEAL, VALVE STEM	16			0.002	
090	1C010-13482	VENTILFUEHRUNG	SHAFT, VALVE BURIGE	8			0.020	
100	1C020-13463	HUBARM, VENTIL	ARM, VALVE BURI.	8			0.062	
110	1C010-13490	PUFFER	PAD	8			0.003	

Update Date : 2020/05/07 Print Date : 2022/03/16

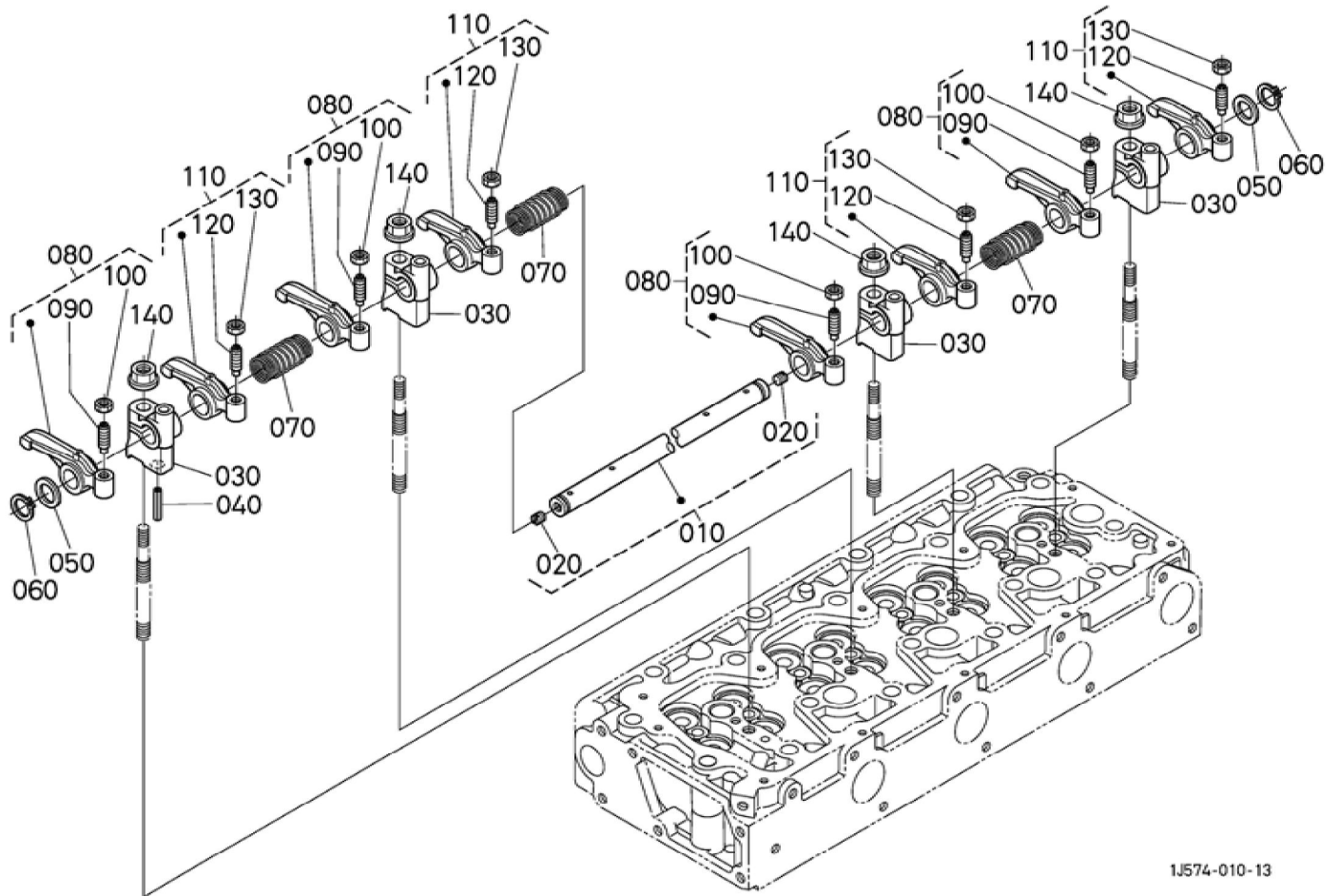



**Download the full PDF manual instantly.**

**Our customer service e-mail:**

**[aservicemanualpdf@yahoo.com](mailto:aservicemanualpdf@yahoo.com)**