



## BKIDK0619 &gt;&gt; M108SDTC &gt;&gt; MOTOR / ENGINE &gt;&gt; 300000 KURBELGHAEUSE / CRANKCASE

Update Date : 2019/01/25 Print Date : 2022/03/15

No.	Part Number	Part Name (POL)	Part Name (ENG)	QTY	IC	Serial No./PIN	Kg	Remarks
010	1J574-01014	KOMP.KURBELGEHAEUSE	COMP.CRANKCASE	1		<=8C4920	60.000	
010	1J574-01016	KOMP.KURBELGEHAEUSE	CRANKCASE, COMP	1	NI	>=8E0001	76.000	
010	1J540-01010	KOMP.KURBELGEHAEUSE	CRANKCASE, COMP	1	>>	>=2DG0001	84.000	
020	15521-96020	STOPFEN	PLUG	2		<=BHZ999	0.003	
020	15521-96020	STOPFEN	PLUG	3		>=BJ0001	0.003	
025	15841-96020	STOPFEN	PLUG	3		<=BHZ999	0.020	
025	15841-96020	STOPFEN	PLUG	2		>=BJ0001	0.020	
030	1C010-96010	STOPFEN	PLUG	1			0.012	
040	16683-96020	STOPFEN	PLUG	1			0.088	
050	15261-03370	STOEPSEL, ABDICHTUNG	CAP, SEALING	4			0.005	
060	15221-03380	STOPFEN	CAP, SEALING	6			0.017	
065	15221-03380	STOPFEN	CAP, SEALING	2			0.017	
070	15221-03390	STOPFEN	CAP, SEALING	1			0.030	
080	1C010-96160	STOPFEN	PLUG, EXPANSION	1			0.050	
090	05012-00820	ZYLINDERSTIFT	PIN, STRAIGHT	1			0.008	
100	05012-01016	ZYLINDERSTIFT	PIN STRAIGHT	2			0.010	
110	15221-33650	ROHRSTIFT	PIN, PIPE	2			0.004	
120	1C010-33640	STIFT	PIN, GEAR CASE	1		<=AA2166	0.019	
120	1C010-33643	STIFT	PIN, STRAIGHT	1	>>	>=AC0001	0.019	
130	1C010-04560	BOLZEN	BOLT, BEARING CASE	10			0.130	
140	1C040-33212	STIFT	PIPE, OIL	1			0.025	
145	1G513-36550	STOPFEN, OELMESSSTAB	PLUG, OIL GAUGE	1			0.004	
150	1J574-71362	ADAPTER	JOINT, PIPE	1		<=8U4065	0.210	
150	1J550-71350	ROHRSCHALTUNG	JOINT, PIPE	1	>>	>=8W0001	0.100	BESTELLEN SIE BITTE POS.150 NEUE TEILE

## BKIDK0619 &gt;&gt; M108SDTC &gt;&gt; MOTOR / ENGINE &gt;&gt; 300000 KURBELGHAUSE / CRANKCASE

Update Date : 2019/01/25 Print Date : 2022/03/15

No.	Part Number	Part Name (POL)	Part Name (ENG)	QTY	IC	Serial No./PIN	Kg	Remarks
150	1J550-71352	ROHRSCHALTUNG	JOINT,PIPE	1	>>	>=9E0001	0.100	
160	1C010-37114	ADAPTER, WASSERROHR	JOINT,WATER PIPE	1			0.020	
170	06311-55030	STOPFEN	PLUG	1			0.050	
180	04724-00170	DICHTUNGSPLATTE	GASKET	1			0.005	
190	1C012-01120	KURBELGHAUSE	CRANKCASE	1		<=2DFZ999	44.050	
190	1C012-01124	KURBELGHAUSE	CRANKCASE	1	>>	>=2DG0001	44.050	
200	1C010-33650	STIFT	PIN,STRAIGHT (CASE,GEAR)	1			0.037	
205	1C011-94510	ZYLINDERSTIFT	PIN,STRAIGHT	2			0.040	
210	1C010-33080	BLINDSTOPFEN	ASSY PLUG,OIL FILLER	1			0.018	
220	E9151-33140	OELEINFUELLSTOPFEN	PLUG(OIL FILLER)	1			0.017	
230	04817-50300	O RING	O RING	1			0.001	
240	15602-33110	EINFUELLFLANSCH	FLANGE,OIL FILLER	1			0.100	
250	15625-32890	DICHTUNGSPLATTE	GASKET	1			0.001	
260	01754-50820	SCHRAUBE	BOLT,FLANGE	2			0.015	
270	1C011-91012	SCHRAUBE	BOLT,FLANGE	2			0.100	

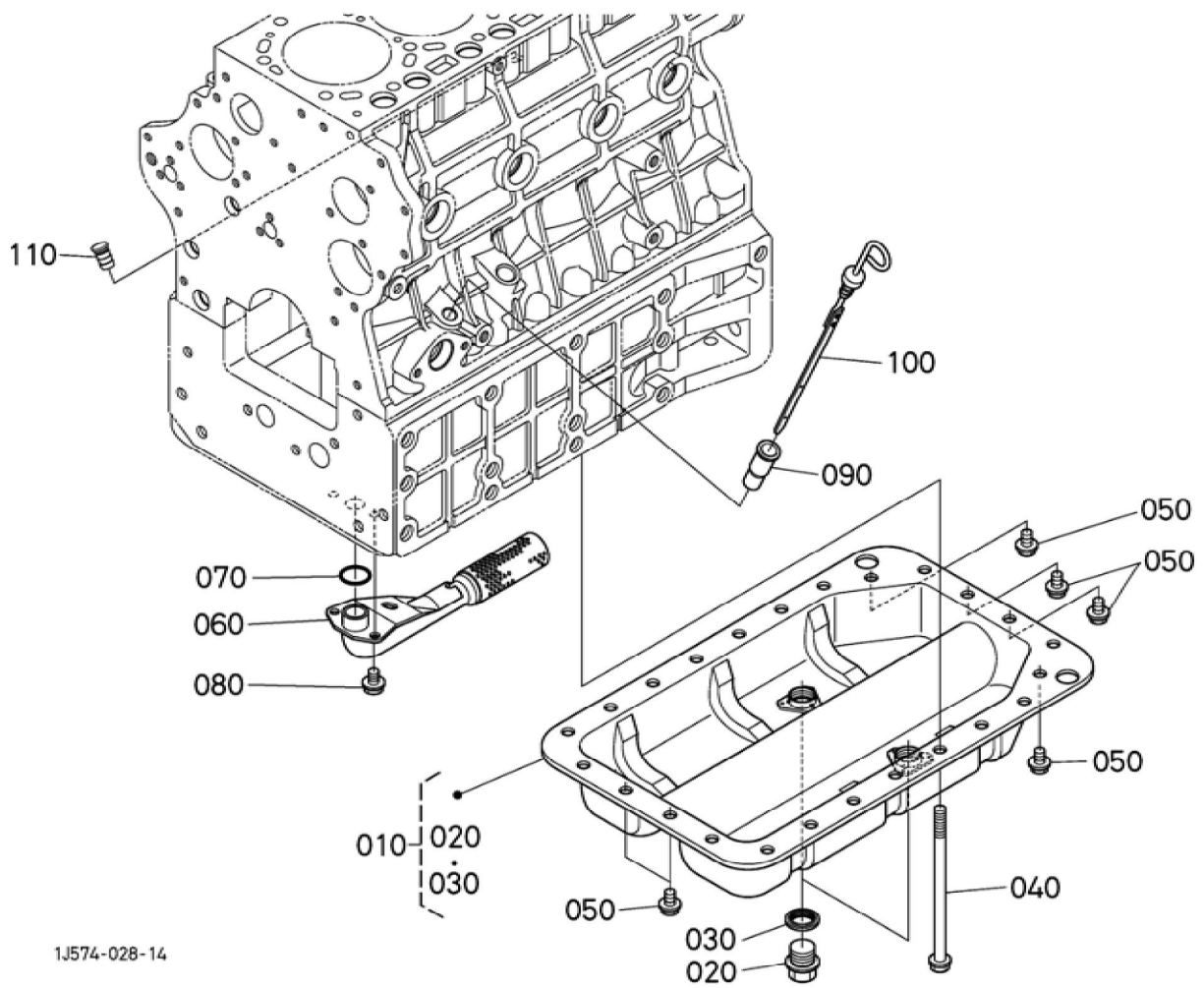

## BKIDK0619 &gt;&gt; M108SDTC &gt;&gt; MOTOR / ENGINE &gt;&gt; 301000 OELWANNE / OIL PAN

Update Date : 2019/01/25 Print Date : 2022/03/15

No.	Part Number	Part Name (POL)	Part Name (ENG)	QTY	IC	Serial No./PIN	Kg	Remarks
010	1G511-01605	KOMP. OELWANNE	PAN,OIL,KIT	1			2.430	
020	15707-33750	ENTLEERUN GSSTOPFEN	PLUG(DRAIN)	2			0.095	
030	16265-96670	DICHTUNG	PACKING	2			0.010	
040	1C011-91012	SCHRAUBE	BOLT,FLANG E	18			0.100	
050	1C010-91100	BOLZEN	BOLT,OILPAN	6			0.020	
060	1C011-32110	OELFILTER	FILTER(OIL)	1			0.280	
070	04814-00220	O RING	O RING	1			0.001	
080	01754-50814	SCHRAUBE	BOLT,FLANG E	2		<=ARZ999	0.012	
080	01754-50812	SCHRAUBE	BOLT,FLANG E	2	>>	>=AS0001	0.010	
090	1C010-36422	FUEHRUNG, OELMESSST AB	GUIDE,OIL GAUGE	1			0.014	
100	1C042-36410	OELMESSST AB	GAUGE,OIL	1			0.030	
110	1G513-36550	STOPFEN, OELMESSST AB	PLUG,OIL GAUGE	1			0.004	

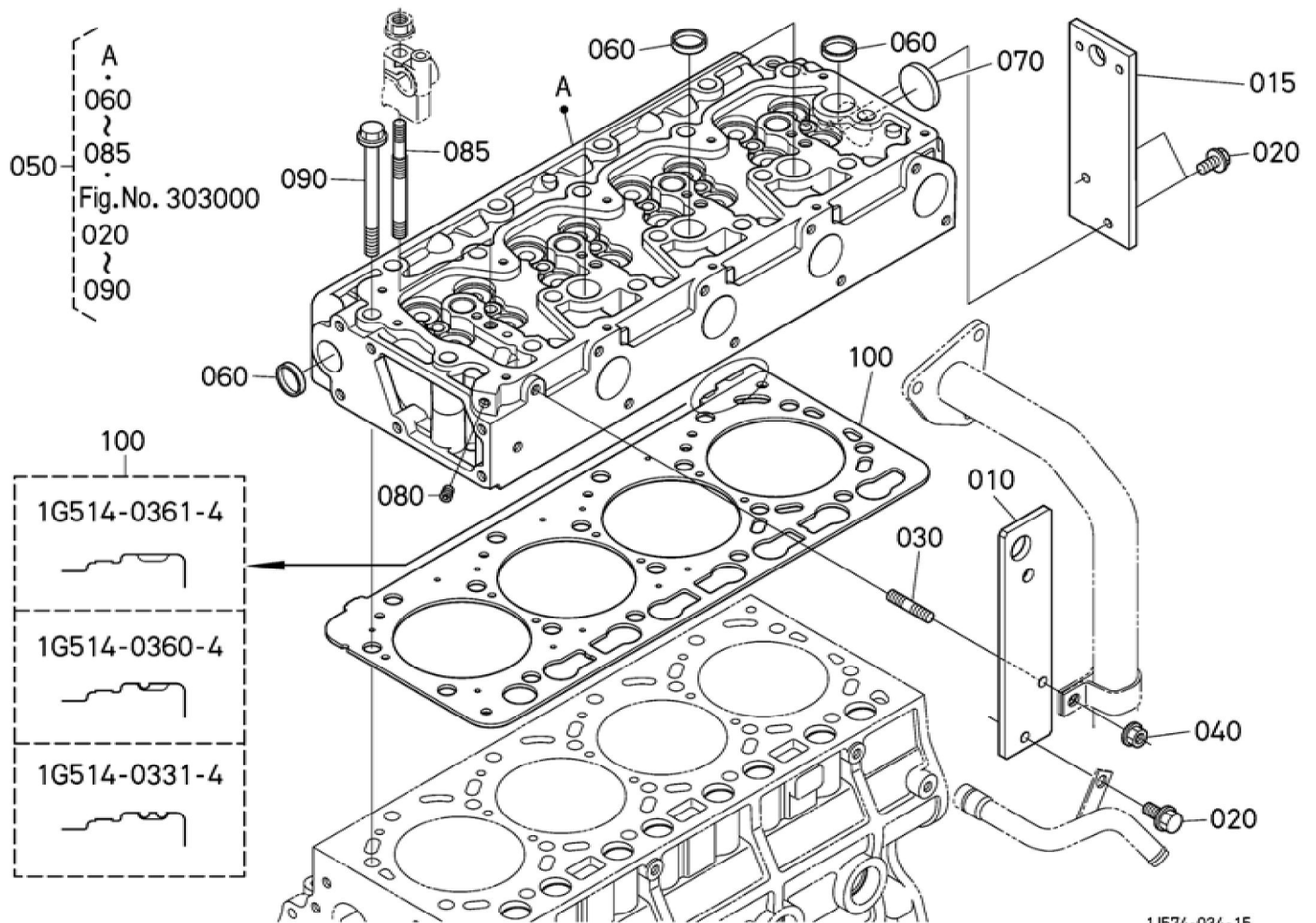

## BKIDK0619 &gt;&gt; M108SDTC &gt;&gt; MOTOR / ENGINE &gt;&gt; 302000 ZYLINDERKOPF / CYLINDER HEAD

Update Date : 2019/01/25 Print Date : 2022/03/15

No.	Part Number	Part Name (POL)	Part Name (ENG)	QTY	IC	Serial No./PIN	Kg	Remarks
010	1J574-01740	MOTORAUFH AENGUNG	HOOK,ENGIN E	1		<=9N1404	0.430	
010	1J574-01743	MOTORAUFH AENGUNG	HOOK,ENGIN E	1	NI	>=9Q0001	0.430	
015	3P705-01740	PLATTE	PLATE,ENGIN E HOOK	1			1.200	
020	01754-50818	SCHRAUBE	BOLT,FLANG E	3		<=CFZ999	0.011	
020	1J500-91020	SCHRAUBE	BOLT,FLANG E	3	>>	>=CG0001	0.012	
030	15221-91530	STEBOLZEN	BOLT,STUD	1		<=CBZ999	0.011	
030	1J542-91632	STEBOLZEN	STUD	1	>>	>=CC0001	0.011	
040	02751-50080	MUTTER	NUT,FLANGE	1			0.006	
050	1J574-03023	GRP.ZYLINDE RKOPF	ASSY CYLINDER HEAD	1		<=AJ2770	26.000	
050	1J574-03025	GRP.ZYLINDE RKOPF	ASSY CYLINDER HEAD	1	>>	>=AL0001	26.000	
050	1J574-03026	GRP.ZYLINDE RKOPF	ASSY CYLINDER HEAD	1	>>	>=2CN0001	26.000	
060	15221-03370	STOPFEN	PLUG,CUP TYPE	5			0.010	
070	15221-03490	STOPFEN	CAP,SEALING	1			0.020	
080	15521-96020	STOPFEN	PLUG	1			0.003	
085	1J574-03410	STEBOLZEN	STUD	4			0.050	
090	1C010-03450	ZYLINDERKO PFSCHRAUB E	BOLT,CYLIND ER HEAD	18			0.100	
100	1G514-03310	ZYLINDERKO PFDICHTUNG	GASKET,CYLI NDER HEAD	1		<=CHZ999	0.230	STD/ 2 KERBEN
100	1G514-03313	ZYLINDERKO PFDICHTUNG	GASKET (HEAD,CYL)	1	>>	>=CJ0001	0.230	STD/ 2 KERBEN
100	1G514-03314	ZYLINDERKO PFDICHTUNG	GASKET,CYL. HEAD	1	>>	>=2DC0001	0.230	STD/ 2 KERBEN
100	1G514-03602	ZYLINDERKO PFDICHTUNG	GASKET,CYL. HEAD	1		<=CHZ999	0.260	VERWENDUN G / 1 KERBE
100	1G514-03603	ZYLINDERKO PFDICHTUNG	GASKET (HEAD,CYL)	1	>>	>=CJ0001	0.260	VERWENDUN G / 1 KERBE
100	1G514-03604	ZYLINDERKO PFDICHTUNG	GASKET,CYL. HEAD	1	>>	>=2DC0001	0.260	VERWENDUN G / 1 KERBE

## BKIDK0619 &gt;&gt; M108SDTC &gt;&gt; MOTOR / ENGINE &gt;&gt; 302000 ZYLINDERKOPF / CYLINDER HEAD

Update Date : 2019/01/25 Print Date : 2022/03/15

No.	Part Number	Part Name (POL)	Part Name (ENG)	QTY	IC	Serial No./PIN	Kg	Remarks
100	1G514-03612	ZYLINDERKO PFDICHTUNG	GASKET,CYL. HEAD	1		<=CHZ999	0.270	VERWENDUN G / KEINE KERBE
100	1G514-03613	ZYLINDERKO PFDICHTUNG	GASKET (HEAD,CYL)	1	>>	>=CJ0001	0.270	VERWENDUN G / KEINE KERBE
100	1G514-03614	ZYLINDERKO PFDICHTUNG	GASKET,CYL. HEAD	1	>>	>=2DC0001	0.270	VERWENDUN G / KEINE KERBE



Update Date : 2019/01/25 Print Date : 2022/03/15

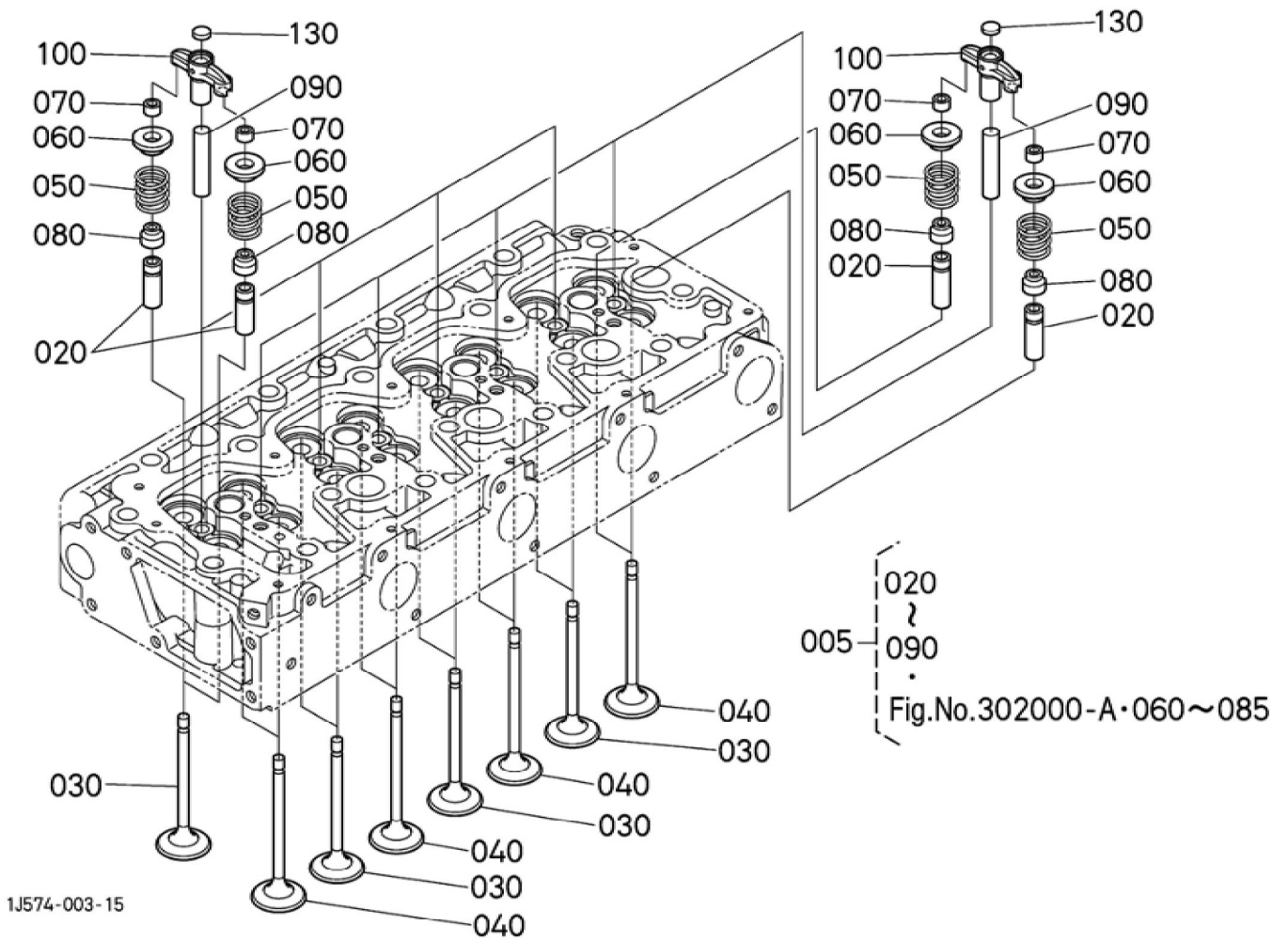

Update Date : 2019/01/25 Print Date : 2022/03/15

No.	Part Number	Part Name (POL)	Part Name (ENG)	QTY	IC	Serial No./PIN	Kg	Remarks
005	1J574-03023	GRP.ZYLINDERKOPF	ASSY CYLINDER HEAD	1		<=AJ2770	26.000	
005	1J574-03025	GRP.ZYLINDERKOPF	ASSY CYLINDER HEAD	1	>>	>=AL0001	26.000	
005	1J574-03026	GRP.ZYLINDERKOPF	ASSY CYLINDER HEAD	1	>>	>=2CN0001	26.000	
020	16261-13560	AUSLASSVENTILFUEHRUNG	GUIDE, EXHAUST VALVE	8		<=AJ2770	0.019	
020	16261-13560	AUSLASSVENTILFUEHRUNG	GUIDE, EXHAUST VALVE	16	NI	>=AL0001	0.019	
030	1C020-13112	EINLASSVENTIL	VALVE, INLET	8			0.050	
040	1C020-13122	AUSLASSVENTIL	VALVE, EXHAUST	8			0.050	
050	1C010-13240	VENTILFEDER	SPRING, VALVE	16			0.020	
060	16261-13330	HALTER, VENTILFEDER	RETAINER, VALVE SP.	16			0.015	
070	15261-13980	KLEMMSCHEIBE	COLLET (VALVE SPRING)	16			0.002	SET
080	1C010-13150	VENTILDICHTUNG	SEAL, VALVE STEM	16			0.002	
090	1C010-13482	VENTILFUEHRUNG	SHAFT, VALVE BURIGE	8			0.020	
100	1C020-13460	HALTER	ASSY ARM, VALVE BRIGE	8		<=8U4065	0.062	
100	1C020-13463	HUBARM, VENTIL	ARM, VALVE BURI.	8	>>	>=8W0001	0.062	
130	1C010-13490	PUFFER	PAD	8			0.003	



**Download the full PDF manual instantly.**

**Our customer service e-mail:**

**[aservicemanualpdf@yahoo.com](mailto:aservicemanualpdf@yahoo.com)**