

BKIDK5148 >> L4630DT >> MOTOR / ENGINE >> 000101 KURBELGHAEUSE / CRANKCASE

Update Date : 18-01-2019 Print Date : 07-03-2022

No.	Part Number	Part Name (POL)	Part Name (ENG)	QTY	IC	Serial No./PIN	Kg	Remarks
010	1A081-01013	KOMP.KURBELGEHAEUSE	COMP.CRANKCASE	1		<=3Q3269	54.500	
010	1A081-01014	KOMP.KURBELGEHAEUSE	COMP.CRANKCASE	1	NI	>=3S0001	54.500	
020	15521-96020	STOPFEN	PLUG	6			0.003	
030	15521-96030	STOPFEN	PLUG	2			0.007	
040	17391-96160	STOPFEN	PLUG,EXPANSION	3			0.003	
050	16271-96160	STOPFEN	PLUG,EXPANSION	1			0.025	
060	15221-03380	STOPFEN	CAP,SEALING	6			0.017	
070	15221-03390	STOPFEN	CAP,SEALING	2			0.030	
080	15261-03370	STOEPSEL,ABDICHTUNG	CAP,SEALING	1			0.005	
090	1A091-03380	STOPFEN	PLUG,WEIGHT SHAFT	2			0.005	
100	05012-00408	ZYLINDERSTIFT	PIN,STRAIGHT	2			0.001	
110	05012-00609	ZYLINDERSTIFT	PIN,STRAIGHT	3			0.003	
120	05012-00612	ZYLINDERSTIFT	PIN,STRAIGHT	2			0.003	
130	05012-01018	ZYLINDERSTIFT	PIN,STRAIGHT	1			0.012	
140	15221-33650	ROHRSTIFT	PIN,PIPE	1			0.004	
150	15321-73340	WASSERROHR	PIPE(WATER RETURN)	1			0.016	
155	1A091-26990	METALLTEIL	METAL (SHAFT,WEIGHT)	2			0.026	
156	1A091-26980	METALLTEIL	METAL (SHAFT,WEIGHT)	2			0.022	
157	1A091-26970	METALLTEIL	METAL (SHAFT,WEIGHT)	2			0.012	
160	15469-33610	STOPFEN	PLUG	1			0.008	
170	15021-33660	DICHTUNGSPLATTE	PACKING	1			0.001	
180	16427-33141	OELEINFUELLSSTOPFEN	PLUG,OIL FILLER	1		<=5C5663	0.000	

BKIDK5148 >> L4630DT >> MOTOR / ENGINE >> 000101 KURBELGHAUSE / CRANKCASE

Update Date : 18-01-2019 Print Date : 07-03-2022

No.	Part Number	Part Name (POL)	Part Name (ENG)	QTY	IC	Serial No./PIN	Kg	Remarks
180	16427-33142	OELEINFUEL LSSTOPFEN	PLUG(OIL FILLER)	1	>>	>=5E0001	0.025	
190	1A021-33110	FLANSCH	FLANGE,OIL FILLER	1			0.070	
200	1A021-51660	DICHTUNGSP LATTE	GASKET, PUMP COVER	1			0.003	
210	01023-50618	BOLZEN	BOLT,SEMS	1			0.006	
220	1E013-35011	GRP.OELPUM PE	ASSY PUMP,OIL	1		<=4L6191	0.000	
220	1E013-35013	GRP.OELPUM PE	ASSY PUMP,OIL	1	>>	>=4N0001	0.570	
230	1A021-35150	DICHTUNGSP LATTE	GASKET,OIL PUMP	1			0.001	
240	01023-50650	BOLZEN	BOLT,SEMS	4			0.012	
250	19202-35660	ZAHNRAD	GEAR,OIL PUMP DRIVE	1			0.230	
260	05712-00410	KEIL	KEY,FEATHE R	1			0.001	
270	15221-35682	MUTTER	NUT	1			0.014	
280	1A021-57483	TRAEGER	BRACKET (ACCEL.CABL E)	1			0.125	
290	01023-50622	BOLZEN	BOLT,SEMS	3			0.005	

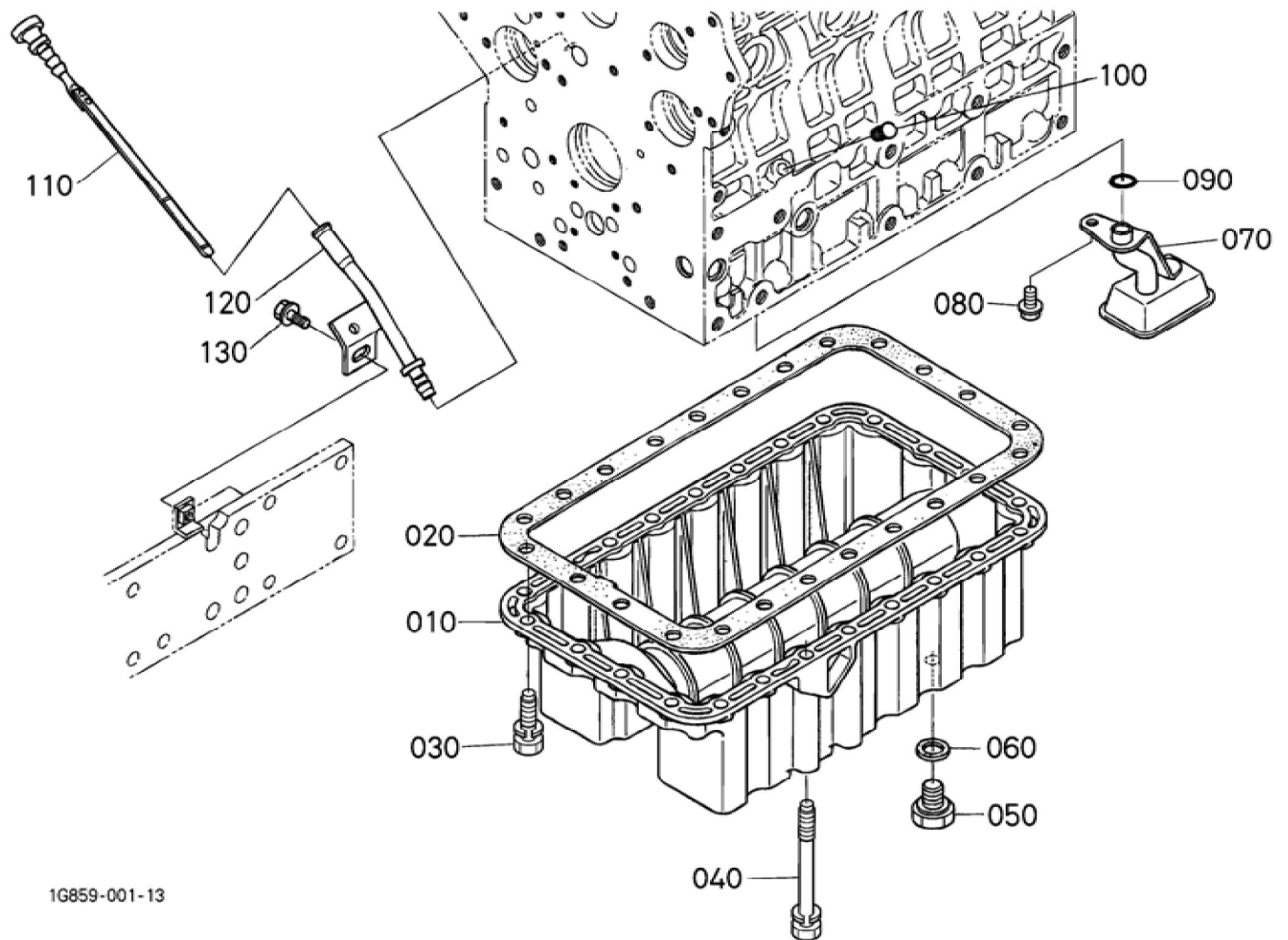

BKIDK5148 >> L4630DT >> MOTOR / ENGINE >> 000200 OL-FANGER / OIL PAN

Update Date : 18-01-2019 Print Date : 07-03-2022

No.	Part Number	Part Name (POL)	Part Name (ENG)	QTY	IC	Serial No./PIN	Kg	Remarks
010	17341-01610	OELWANNE	OIL PAN	1			4.100	
020	1A091-01620	DICHTUNG	GASKET,OIL PAN	1			0.018	
030	01133-51028	BOLZEN	BOLT,SEMS	22		<=5Q6609	0.027	
030	1A091-91010	BOLZEN	BOLT,SEMS	22	>>	>=5S0001	0.025	
040	17377-91010	BOLZEN	BOLT	2		<=5Q6609	0.080	
040	1A091-91020	BOLZEN	BOLT	2	>>	>=5S0001	0.075	
050	16427-33750	ENTLEERUNG GSSTOPFEN	PLUG,DRAIN	2			0.030	
060	6C090-58960	DICHTUNGSP LATTE	GASKET	2			0.005	
070	15411-32110	OELFILTER	FILTER(OIL)	1			0.240	
080	01123-50814	BOLZEN	BOLT,SEMS	1			0.010	
080	01754-50812	SCHRAUBE	BOLT,FLANG E	1	=		0.010	
090	04817-00160	O RING	O RING	1			0.001	
100	16414-33641	STOPFENOE LMESSTAB	PLUG,OIL GAUGE	1			0.000	
100	1G513-36550	STOPFEN, OELMESST AB	PLUG,OIL GAUGE	1	=		0.004	
110	T1060-16602	OELMESST AB	GAUGE,OIL	1			0.015	
120	TD060-16612	FUEHRUNG, OELMESST AB	GUIDE,OIL GAUGE	1		<=5E6053	0.075	
120	TD060-16614	FUEHRUNG, OELMESST AB	GUIDE (GAUGE,OIL)	1	>>	>=5G0001	0.075	
130	01754-50816	SCHRAUBE	BOLT,FLANG E	1			0.011	

Update Date : 18-01-2019 Print Date : 07-03-2022

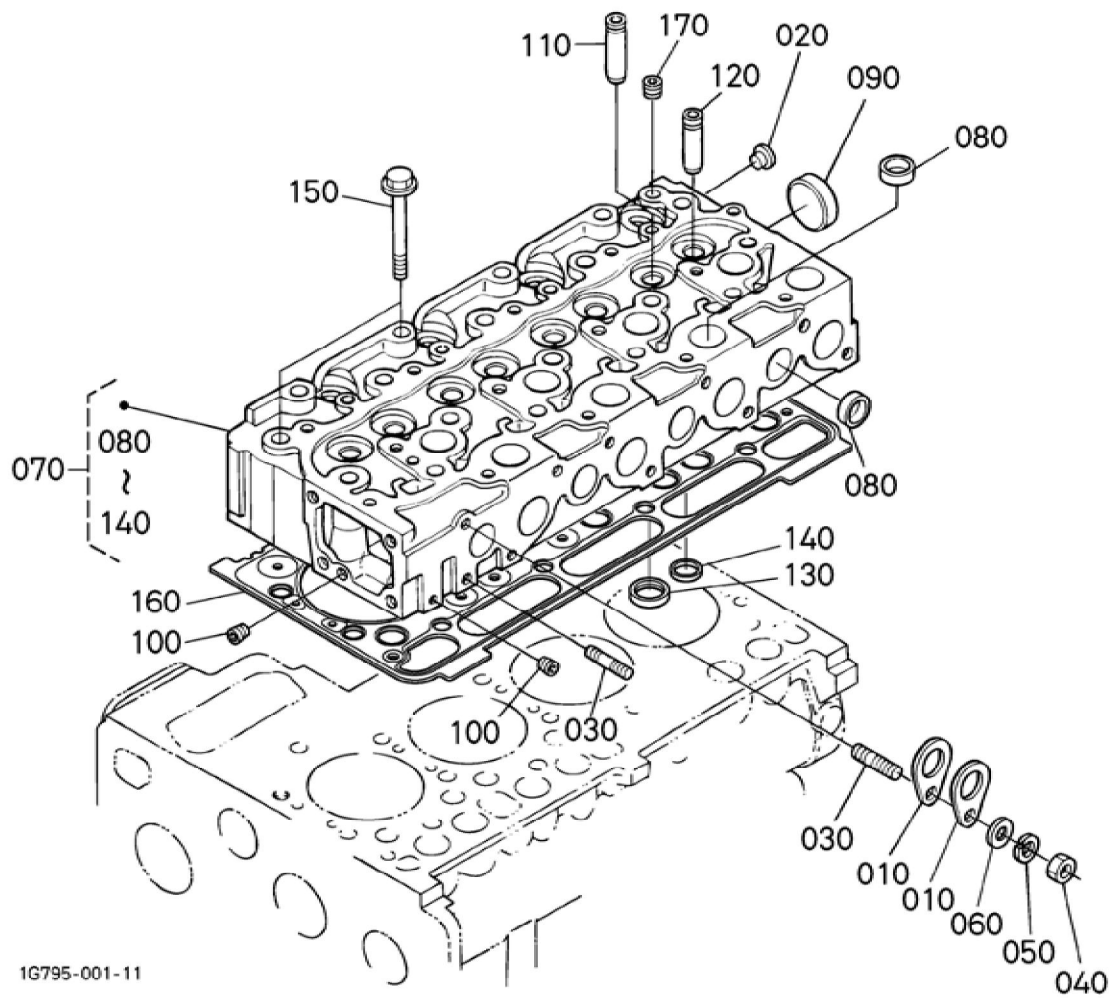

1G795-001-11

BKIDK5148 >> L4630DT >> MOTOR / ENGINE >> 000301 ZYLINDERKOPF / CYLINDER HEAD

Update Date : 18-01-2019 Print Date : 07-03-2022

No.	Part Number	Part Name (POL)	Part Name (ENG)	QTY	IC	Serial No./PIN	Kg	Remarks
010	15221-01750	MOTORHAKE N	HOOK,ENGIN E	2			0.040	
020	09980-10075	KAPPE	CAP,PROTEC TOR	1			0.001	
030	15471-91530	STEBOLZEN	BOLT,STUD	2			0.010	
040	02156-50080	MUTTER	HEX.NUT	1			0.004	
050	04512-50080	FEDERRING	WASHER SPRING	1			0.002	
060	04012-50080	SCHEIBE	WASHER,PLA IN	1			0.001	
070	1G780-03042	KOMP.ZYLIN DERKOPF	COMP.CYLIN DER HEAD	1		<=4L6191	20.000	
070	1G780-03043	KOMP.ZYLIN DERKOPF	HEAD,CYL,C OMP	1	>>	>=4N0001	18.500	
080	15221-03370	STOPFEN	PLUG,CUP TYPE	12			0.010	
090	15221-03490	STOPFEN	CAP,SEALING	1			0.020	
100	15261-96010	STOPFEN	PLUG	2			0.002	
110	17321-13580	EINLASSVEN TILFUEHRUN G	GUIDE,INLET VALVE	4			0.015	
110	1G896-13580	EINLASSVEN TILFUEHRUN G	GUIDE,VALVE ,INLET	4	=		0.020	
120	17321-13561	VENTILFUHR UNG	GUIDE,EXHA UST VALVE	4			0.000	
120	1C010-13560	AUSLASSVEN TILFUEHRUN G	GUIDE,EXHA UST VALVE	4	=		0.025	
130	16415-13620	VENTILSITZ, EINLASSVEN TIL	SEAT,VALVE (INLET)	4			0.010	
140	16415-13612	VENTILSITZ, AUSLASSVEN TIL	SEAT (EXHAUST VALVE)	4			0.010	
150	19013-03450	ZYLINDERKO PFSCHRAUB E	BOLT,HEAD (CYLINDER)	18			0.077	
160	1G790-03311	DICTUNG,ZYL INDERKOPF	GASKET,CYLI NDER HEAD	1		<=3Q3269	0.000	
160	1G790-03312	ZYLINDERKO PFDICHTUNG	GASKET,CYL. HEAD	1	>>	>=3S0001	0.290	
170	15841-96020	STOPFEN	PLUG	1			0.020	

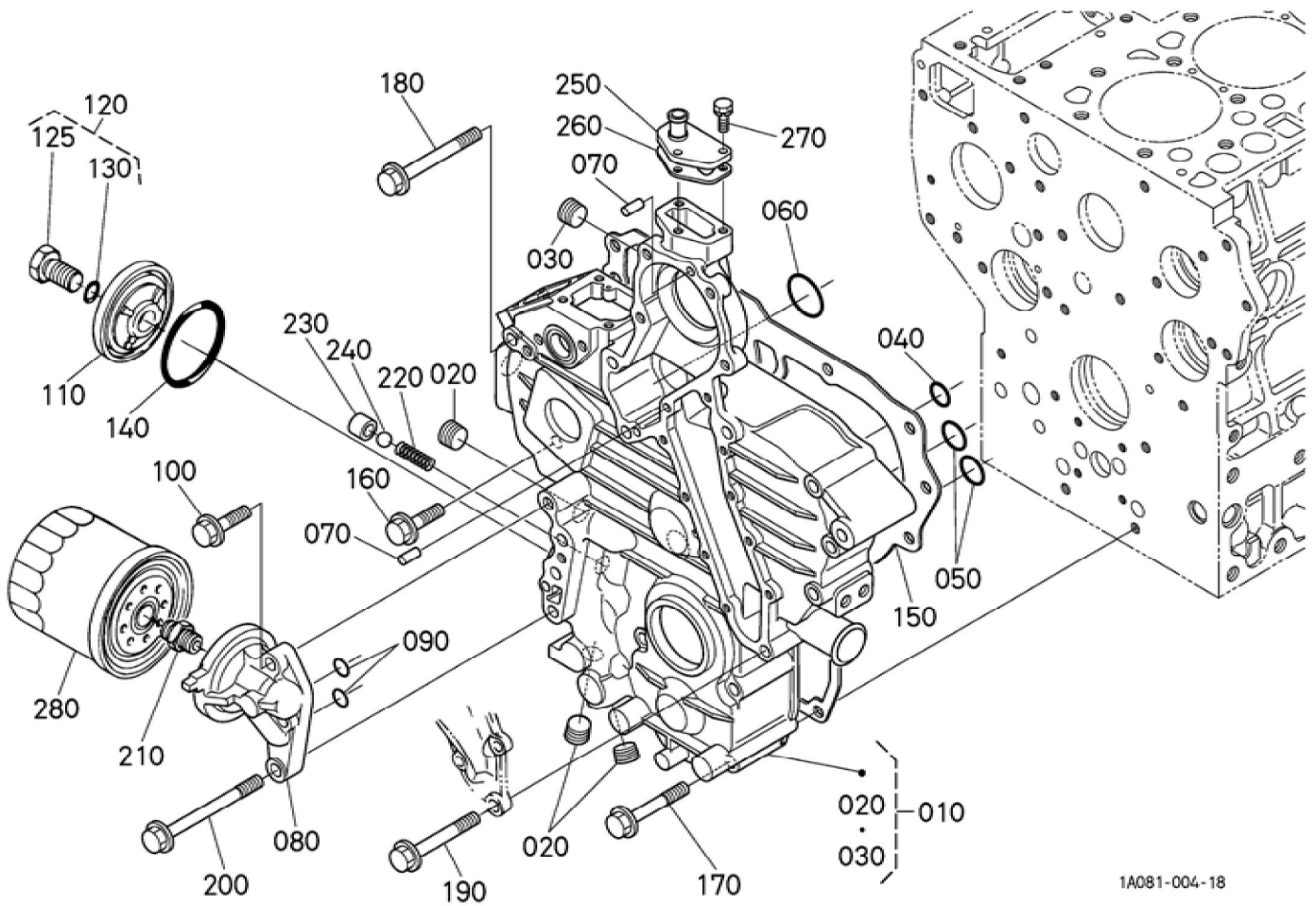

BKIDK5148 >> L4630DT >> MOTOR / ENGINE >> 000401 GETRIEBE GEHAEUSE / GEAR CASE

Update Date : 18-01-2019 Print Date : 07-03-2022

No.	Part Number	Part Name (POL)	Part Name (ENG)	QTY	IC	Serial No./PIN	Kg	Remarks
010	1A081-04023	KMP.GETRIEBEGEHAEUSE	COMP.CASE, GEAR	1		<=4N6089	3.700	
010	1A081-04024	KMP.GETRIEBEGEHAEUSE	COMP.CASE, GEAR	1	>>	>=4Q0001	3.700	
010	1A081-04025	GETRIEBEGEHAEUSE KOMP.	CASE,GEAR, COMP	1	>>	>=5L0001	3.700	
020	16241-96020	STOPFEN	PLUG	3			0.015	
030	1A021-96020	STOPFEN	PLUG	1			0.020	
040	04817-00150	O RING	O RING	1			0.001	
050	04817-00220	O RING	O RING	2			0.001	
060	04817-00360	O RING	O RING	1			0.001	
070	05012-00612	ZYLINDERSTIFT	PIN, STRAIGHT	2			0.003	
080	1A021-32611	BEIMENGUNGOELFILTER	BASE,OIL FILTER	1			0.000	
080	1G742-32610	HALTER, OELFILTER	BASE,OIL FILTER	1	=	<=6L7289	0.245	
080	1G742-32613	HALTER, OELFILTER	BASE(OIL FILTER)	1	>>	>=6N0001	0.245	
090	04817-00150	O RING	O RING	2			0.001	
100	01123-50835	BOLZEN	BOLT,SEMS	2		<=5V9999	0.020	
100	01754-50830	SCHRAUBE	BOLT,FLANGE	2	>>	>=5W0001	0.050	
110	17331-32880	DECKEL	COVER	1			0.075	
120	17331-32910	KOMP.BOLZEN	BOLT,COMP	1			0.070	
125	17331-32900	BOLZEN	BOLT	1			0.060	
130	04817-00150	O RING	O RING	1			0.001	
140	19202-96830	O RING	O RING	1			0.010	
150	1A091-04130	DICHTUNG	GASKET (CASE,GEAR)	1			0.018	
160	01123-50835	BOLZEN	BOLT,SEMS	1		<=5V9999	0.020	
160	01754-50830	SCHRAUBE	BOLT,FLANGE	1	>>	>=5W0001	0.050	
170	01123-50870	BOLZEN	BOLT,SEMS	7		<=5V9999	0.029	
170	1A021-91030	SCHRAUBE	BOLT,SEMS	7	>>	>=5W0001	0.030	
180	17367-91010	BOLZEN	BOLT	2		<=5V9999	0.005	



Download the full PDF manual instantly.

Our customer service e-mail:

aservicemanualpdf@yahoo.com