

BKIDK5376 >> L1-452DT-NEC >> MOTOR / ENGINE >> 500001 KURBELGHAEUSE / CRANKCASE

Update Date : 04-03-2021 Print Date : 03-03-2022

No.	Part Number	Part Name (POL)	Part Name (ENG)	QTY	IC	Serial No./PIN	Kg	Remarks
010	1J810-01010	KOMP.KURBELGEHAEUSE	CRANKCASE, COMP	1			68.000	
020	15521-96020	STOPFEN	PLUG	5			0.003	
030	15521-96030	STOPFEN	PLUG	2			0.007	
040	17391-96160	STOPFEN	PLUG,EXPANSION	3			0.003	
050	16271-96160	STOPFEN	PLUG,EXPANSION	1			0.025	
060	15221-03380	STOPFEN	CAP,SEALING	4			0.017	
070	1J860-71010	KOMP.WASSERROHR	PIPE,COMP	2			0.063	
080	15221-03390	STOPFEN	CAP,SEALING	2			0.030	
090	15261-03370	STOEPSEL,ABDICHTUNG	CAP,SEALING	1			0.005	
100	1A091-03380	STOPFEN	PLUG,WEIGHT SHAFT	2			0.005	
110	05012-00609	ZYLINDERSTIFT	PIN,STRAIGHT	2			0.003	
120	05012-00612	ZYLINDERSTIFT	PIN, STRAIGHT	2			0.003	
130	05012-01018	ZYLINDERSTIFT	PIN,STRAIGHT	1			0.012	
140	15221-33650	ROHRSTIFT	PIN,PIPE	1			0.004	
150	15321-73340	WASSERROHR	PIPE(WATER RETURN)	1			0.016	
160	1A091-26990	METALLTEIL	METAL (SHAFT,WEIGHT)	2			0.026	
170	1G425-26980	METALLTEIL	METAL (SHAFT,WEIGHT,2)	2			0.030	
180	1A091-26970	METALLTEIL	METAL (SHAFT,WEIGHT)	2			0.012	
185	1G896-33610	BOLZEN	PLUG	1			0.008	
186	15021-33660	DICHTUNGSPLATTE	PACKING	1			0.001	
190	1E013-35013	GRP.OELPUMPE	ASSY PUMP,OIL	1			0.570	
200	1A021-35150	DICHTUNGSPLATTE	GASKET,OIL PUMP	1			0.001	

Update Date : 04-03-2021 Print Date : 03-03-2022

No.	Part Number	Part Name (POL)	Part Name (ENG)	QTY	IC	Serial No./PIN	Kg	Remarks
210	01023-50650	BOLZEN	BOLT,SEMS	4			0.012	
220	1G896-35660	ZAHNRAD	GEAR,OIL PUMP DRIVE	1			0.135	
230	05712-00410	KEIL	KEY,FEATHER	1			0.001	
240	15221-35682	MUTTER	NUT	1			0.014	
250	1J803-39052	ZWISCHENSTUECK	ADAPTER (SWITCH,OIL)	1			0.025	

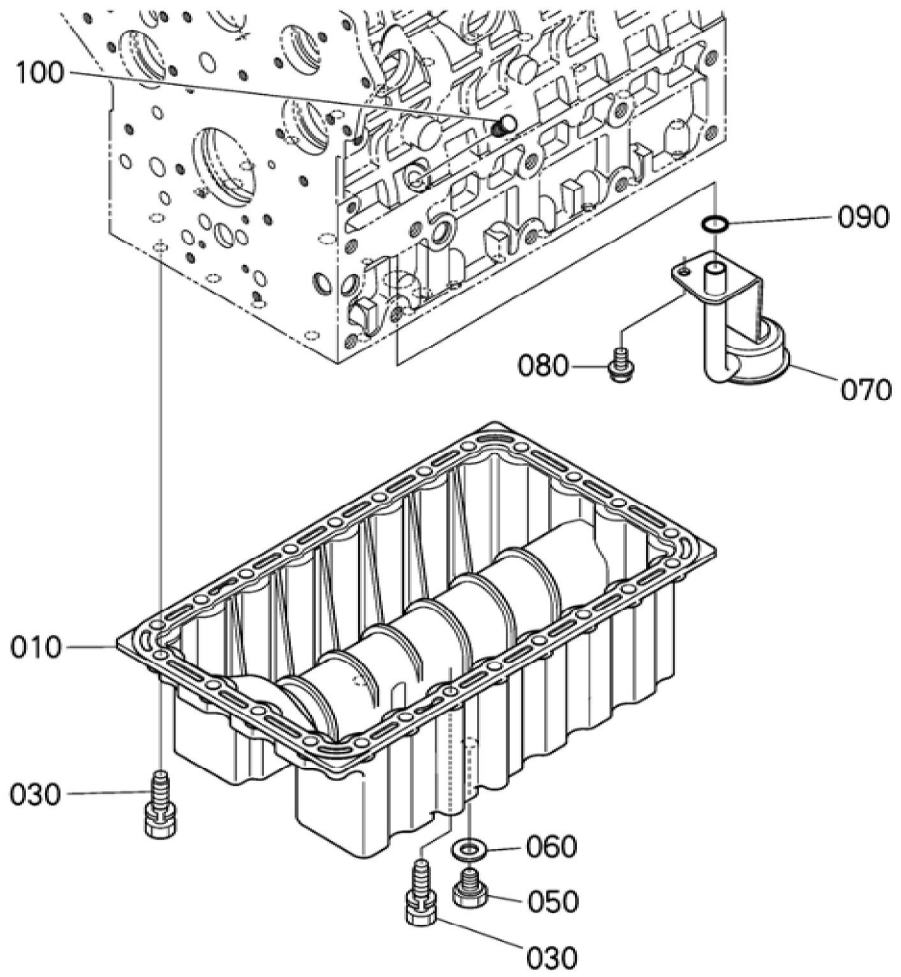

BKIDK5376 >> L1-452DT-NEC >> MOTOR / ENGINE >> 501001 OELWANNE / OIL PAN

Update Date : 04-03-2021 Print Date : 03-03-2022

No.	Part Number	Part Name (POL)	Part Name (ENG)	QTY	IC	Serial No./PIN	Kg	Remarks
010	1G425-01613	OELWANNE	OIL PAN	1			4.000	
030	1A091-91010	BOLZEN	BOLT,SEMS	24			0.025	
050	16427-33750	ENTLEERUNGSSTOPFEN	PLUG,DRAIN	2			0.030	
060	6C090-58960	DICHTUNGSPLATTE	GASKET	2			0.005	
070	1J854-32110	KRAFTSTOFFFILTER	FILTER(OIL,1)	1			0.250	
080	01754-50812	SCHRAUBE	BOLT,FLANGE	1			0.008	
090	04817-00160	O RING	O RING	1			0.001	
100	1G513-36550	STOPFEN, OELMESSSTAB	PLUG,OIL GAUGE	1			0.004	

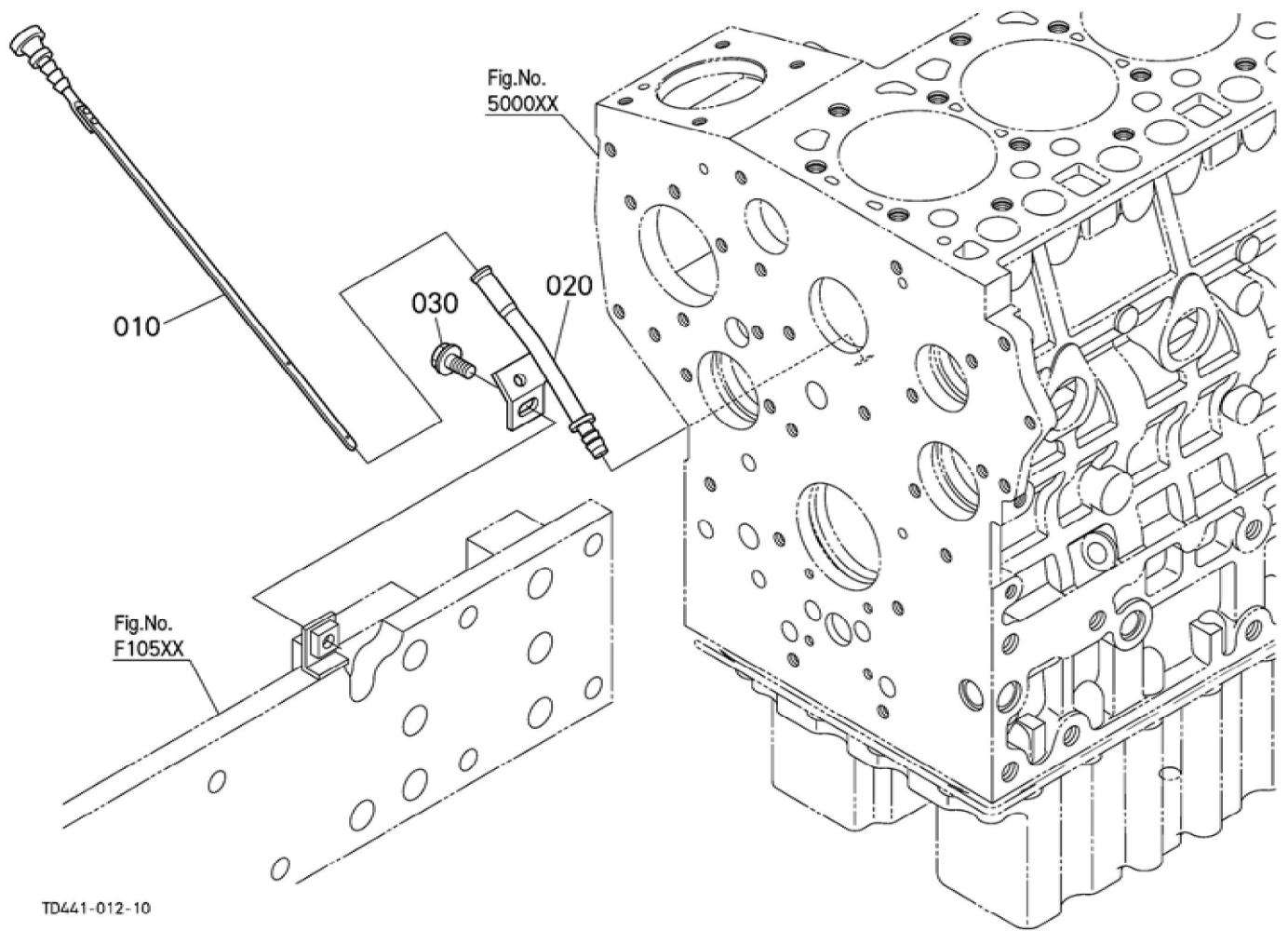

Update Date : 04-03-2021 Print Date : 03-03-2022

No.	Part Number	Part Name (POL)	Part Name (ENG)	QTY	IC	Serial No./PIN	Kg	Remarks
010	T1060-16602	OELMESSSTAB	GAUGE,OIL	1			0.015	
020	TD060-16615	FUEHRUNG, OELMESSSTAB	GUIDE,OIL GAUGE	1			0.075	
030	01754-50816	SCHRAUBE	BOLT,FLANGE	1			0.011	

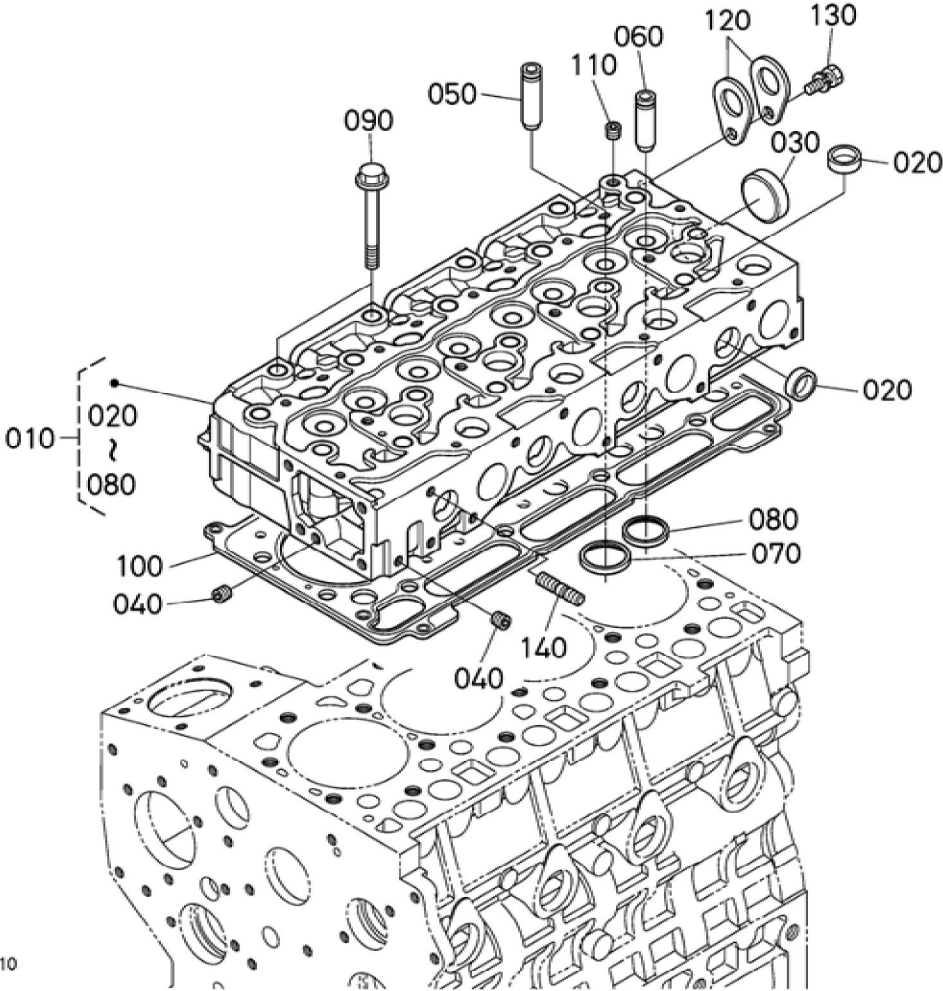

BKIDK5376 >> L1-452DT-NEC >> MOTOR / ENGINE >> 502000 ZYLINDERKOPF / CYLINDER HEAD

Update Date : 04-03-2021 Print Date : 03-03-2022

No.	Part Number	Part Name (POL)	Part Name (ENG)	QTY	IC	Serial No./PIN	Kg	Remarks
010	1J810-03040	ZYLINDERKOPF,KOMP.	HEAD,CYLINDER,COMP	1			18.500	
020	15221-03370	STOPFEN	PLUG,CUP TYPE	12			0.010	
030	15221-03490	STOPFEN	CAP,SEALING	1			0.020	
040	15261-96010	STOPFEN	PLUG	2			0.002	
050	1J829-13580	VENTILFUEHRUNG	GUIDE,VALVE (INLET)	4			0.020	
060	1J829-13560	VENTILFUEHRUNG	GUIDE,VALVE (EXHAUST)	4			0.020	
070	1J812-13620	VENTILSITZ	SEAT,VALVE (INLET)	4			0.010	
080	1J812-13610	VENTILSITZ AUSPUFF	SEAT,VALVE (EXHAUST)	4			0.010	
090	19013-03450	ZYLINDERKOPFSCHRAUBE	BOLT,HEAD (CYLINDER)	18			0.077	
100	1J897-03600	DICHTUNG	GASKET (HEAD,CYLINDER 115)	1			0.275	1.15mm
100	1J897-03310	DICHTUNG	GASKET (HEAD,CYLINDER 120)	1			0.275	1.20mm
100	1J897-03610	DICHTUNG	GASKET (HEAD,CYLINDER 125)	1			0.275	1.25mm
100	1J897-03620	DICHTUNG	GASKET (HEAD,CYLINDER 130)	1			0.270	1.30mm
100	1J897-03630	DICHTUNG	GASKET (HEAD,CYLINDER 135)	1			0.275	1.35mm
110	15841-96020	STOPFEN	PLUG	1			0.020	
120	15221-01750	MOTORHAKEN	HOOK,ENGINE	2			0.040	
130	01123-50816	SCHRAUBE	BOLT,SEMS	1			0.011	
140	15471-91530	STEBOLZEN	BOLT,STUD	1			0.010	

Update Date : 04-03-2021 Print Date : 03-03-2022

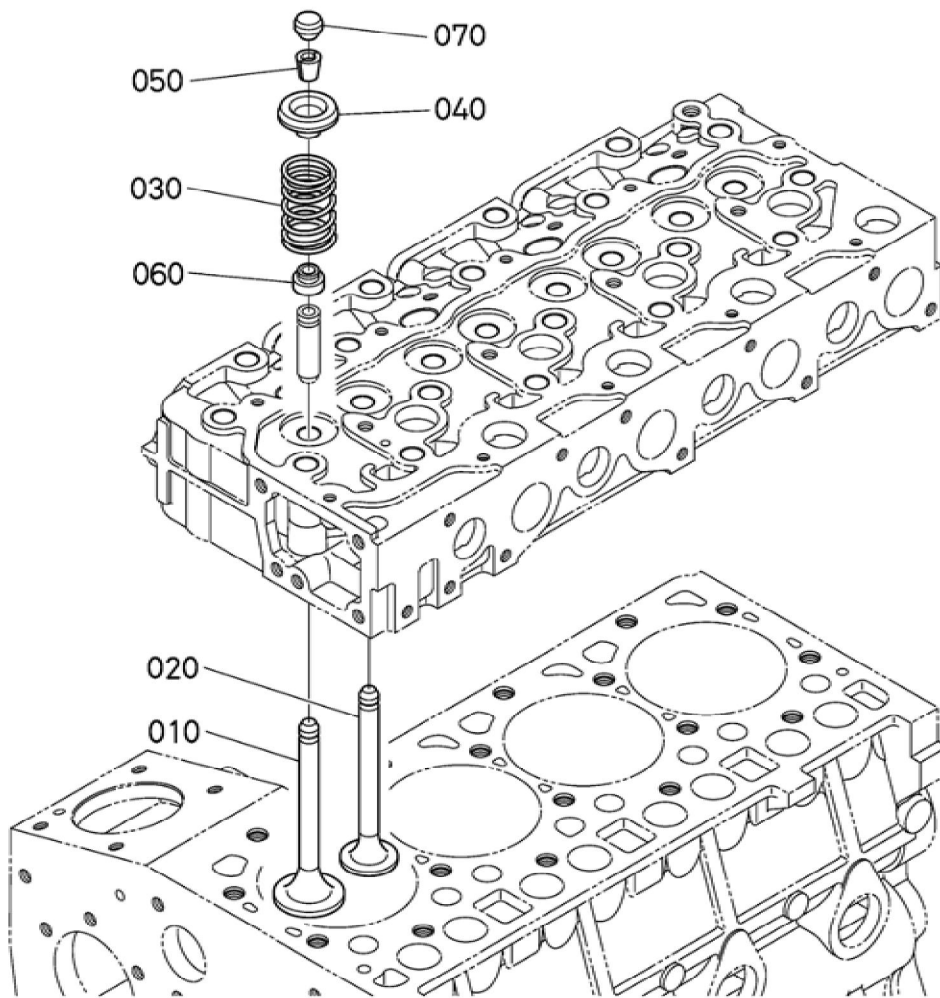

1J800-004-11

Update Date : 04-03-2021 Print Date : 03-03-2022

No.	Part Number	Part Name (POL)	Part Name (ENG)	QTY	IC	Serial No./PIN	Kg	Remarks
010	1G852-13114	VENTIL	VALVE,INLET	4			0.080	
020	1G852-13124	VENTIL	VALVE,EXHAUST	4			0.065	
030	1G896-13240	VENTIL-FEDER	SPRING,VALVE	8			0.040	
040	15221-13330	HALTER	RETAINER,VALVE SP.	8			0.028	
050	15221-13980	KLEMMSCHEIBE	COLLET,VALVE SPRING	8			0.005	SET
060	15221-13153	VENTILDICHTUNG	SEAL(VALVE STEM)	8			0.002	
070	1G896-13280	VENTILKAPPE	CAP(VALVE)	8			0.005	

Update Date : 04-03-2021 Print Date : 03-03-2022

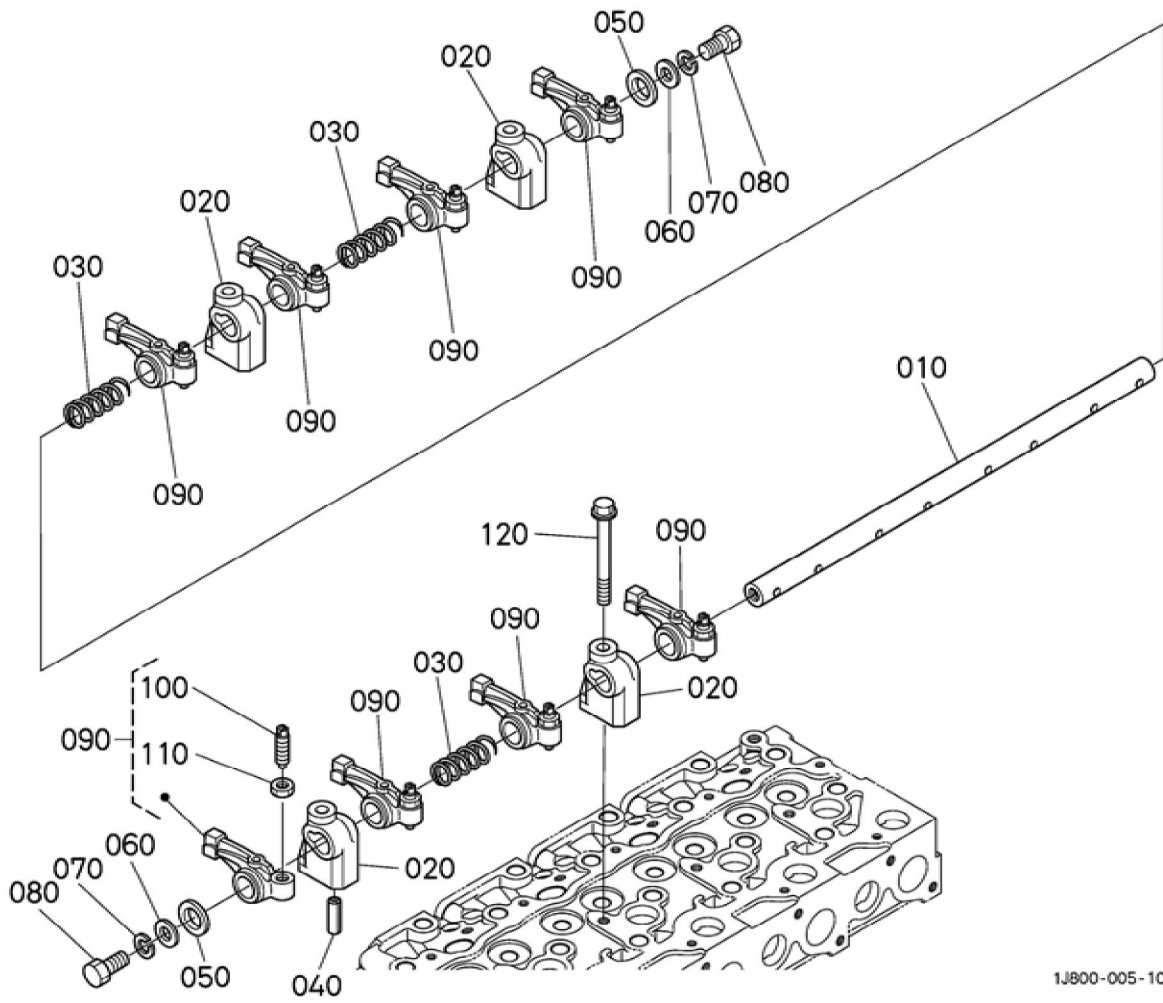



Download the full PDF manual instantly.

Our customer service e-mail:

aservicemanualpdf@yahoo.com