

SHOP  
MANUAL

**KOMATSU**  
**WD420-3**

MACHINE MODEL	SERIAL No.
WD420-3	53101 and up

**KOMATSU**

# CONTENTS

	No. of page
<b>01 GENERAL .....</b>	<b>01-1</b>
<b>10 STRUCTURE AND FUNCTION .....</b>	<b>10-1</b>
<b>20 TESTING AND ADJUSTING .....</b>	<b>20-1</b>
<b>30 DISASSEMBLY AND ASSEMBLY .....</b>	<b>30-1</b>
<b>40 MAINTENANCE STANDARD .....</b>	<b>40-1</b>

# SAFETY

## SAFETY NOTICE

### IMPORTANT SAFETY NOTICE

Proper service and repair is extremely important for safe machine operation. The service and repair techniques recommended by Komatsu and described in this manual are both effective and safe. Some of these techniques require the use of tools specially designed by Komatsu for the specific purpose.

To prevent injury to workers, the symbol  is used to mark safety precautions in this manual. The cautions accompanying these symbols should always be followed carefully. If any dangerous situation arises or may possibly arise, first consider safety, and take the necessary actions to deal with the situation.

### GENERAL PRECAUTIONS

Mistakes in operation are extremely dangerous. Read the Operation and Maintenance Manual carefully BEFORE operating the machine.

1. Before carrying out any greasing or repairs, read all the precautions given on the decals which are fixed to the machine.
2. When carrying out any operation, always wear safety shoes and helmet. Do not wear loose work clothes, or clothes with buttons missing.
  - Always wear safety glasses when hitting parts with a hammer.
  - Always wear safety glasses when grinding parts with a grinder, etc.
3. If welding repairs are needed, always have a trained, experienced welder carry out the work. When carrying out welding work, always wear welding gloves, apron, hand shield, cap and other clothes suited for welding work.
4. When carrying out any operation with two or more workers, always agree on the operating procedure before starting. Always inform your fellow workers before starting any step of the operation. Before starting work, hang UNDER REPAIR signs on the controls in the operator's compartment.
5. Keep all tools in good condition and learn the correct way to use them.

6. Decide a place in the repair workshop to keep tools and removed parts. Always keep the tools and parts in their correct places. Always keep the work area clean and make sure that there is no dirt or oil on the floor. Smoke only in the areas provided for smoking. Never smoke while working.

### PREPARATIONS FOR WORK

7. Before adding oil or making any repairs, park the machine on hard, level ground, and block the wheels or tracks to prevent the machine from moving.
8. Before starting work, lower blade, ripper, bucket or any other work equipment to the ground. If this is not possible, insert the safety pin or use blocks to prevent the work equipment from falling. In addition, be sure to lock all the control levers and hang warning signs on them.
9. When disassembling or assembling, support the machine with blocks, jacks or stands before starting work.
10. Remove all mud and oil from the steps or other places used to get on and off the machine. Always use the handrails, ladders or steps when getting on or off the machine. Never jump on or off the machine. If it is impossible to use the handrails, ladders or steps, use a stand to provide safe footing.

**PRECAUTIONS DURING WORK**

11. When removing the oil filler cap, drain plug or hydraulic pressure measuring plugs, loosen them slowly to prevent the oil from spurting out.  
Before disconnecting or removing components of the oil, water or air circuits, first remove the pressure completely from the circuit.
12. The water and oil in the circuits are hot when the engine is stopped, so be careful not to get burned.  
Wait for the oil and water to cool before carrying out any work on the oil or water circuits.
13. Before starting work, remove the leads from the battery. Always remove the lead from the negative (-) terminal first.
14. When raising heavy components, use a hoist or crane.  
Check that the wire rope, chains and hooks are free from damage.  
Always use lifting equipment which has ample capacity.  
Install the lifting equipment at the correct places. Use a hoist or crane and operate slowly to prevent the component from hitting any other part. Do not work with any part still raised by the hoist or crane.
15. When removing covers which are under internal pressure or under pressure from a spring, always leave two bolts in position on opposite sides. Slowly release the pressure, then slowly loosen the bolts to remove.
16. When removing components, be careful not to break or damage the wiring. Damaged wiring may cause electrical fires.
17. When removing piping, stop the fuel or oil from spilling out. If any fuel or oil drips onto the floor, wipe it up immediately. Fuel or oil on the floor can cause you to slip, or can even start fires.
18. As a general rule, do not use gasoline to wash parts. In particular, use only the minimum of gasoline when washing electrical parts.
19. Be sure to assemble all parts again in their original places.  
Replace any damaged parts with new parts.
  - When installing hoses and wires, be sure that they will not be damaged by contact with other parts when the machine is being operated.
20. When installing high pressure hoses, make sure that they are not twisted. Damaged tubes are dangerous, so be extremely careful when installing tubes for high pressure circuits. Also, check that connecting parts are correctly installed.
21. When assembling or installing parts, always use the specified tightening torques. When installing protective parts such as guards, or parts which vibrate violently or rotate at high speed, be particularly careful to check that they are installed correctly.
22. When aligning two holes, never insert your fingers or hand. Be careful not to get your fingers caught in a hole.
23. When measuring hydraulic pressure, check that the measuring tool is correctly assembled before taking any measurements.
24. Take care when removing or installing the tracks of track-type machines.  
When removing the track, the track separates suddenly, so never let anyone stand at either end of the track.

# FOREWORD

## GENERAL

This shop manual has been prepared as an aid to improve the quality of repairs by giving the serviceman an accurate understanding of the product and by showing him the correct way to perform repairs and make judgements. Make sure you understand the contents of this manual and use it to full effect at every opportunity.

This shop manual mainly contains the necessary technical information for operations performed in a service workshop. For ease of understanding, the manual is divided into the following chapters; these chapters are further divided into the each main group of components.

### STRUCTURE AND FUNCTION

This section explains the structure and function of each component. It serves not only to give an understanding of the structure, but also serves as reference material for troubleshooting.

### TESTING AND ADJUSTING

This section explains checks to be made before and after performing repairs, as well as adjustments to be made at completion of the checks and repairs.

Troubleshooting charts correlating "Problems" to "Causes" are also included in this section.

### DISASSEMBLY AND ASSEMBLY

This section explains the order to be followed when removing, installing, disassembling or assembling each component, as well as precautions to be taken for these operations.

### MAINTENANCE STANDARD

This section gives the judgement standards when inspecting disassembled parts.

### NOTICE

The specifications contained in this shop manual are subject to change at any time and without any advance notice. Use the specifications given in the book with the latest date.

# HOW TO READ THE SHOP MANUAL

## VOLUMES

Shop manuals are issued as a guide to carrying out repairs. They are divided as follows:

**Chassis volume:** Issued for every machine model  
**Engine volume:** Issued for each engine series

**Electrical volume:**  
**Attachments volume:** } Each issued as one volume to cover all models

These various volumes are designed to avoid duplicating the same information. Therefore, to deal with all repairs for any model, it is necessary that chassis, engine, electrical and attachment volumes be available.

## DISTRIBUTION AND UPDATING

Any additions, amendments or other changes will be sent to KOMATSU distributors. Get the most up-to-date information before you start any work.

## FLING METHOD

1. See the page number on the bottom of the page. File the pages in correct order.
2. Following examples show how to read the page number.  
 Example 1

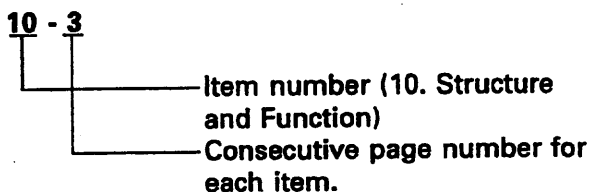

Example 2

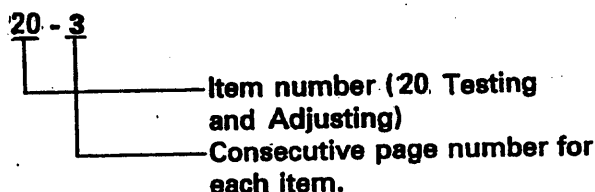

3. Additional pages: Additional pages are indicated by a hyphen (-) and number after the page number. File as in the example.  
 Example:

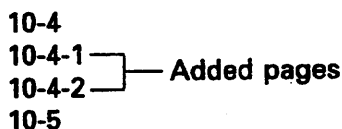

## REVISED EDITION MARK

When a manual is revised, an edition mark (①②③....) is recorded on the bottom of the pages.

## REVISIONS

Revised pages are shown in the LIST OF REVISED PAGES next to the CONTENTS page.

## SYMBOLS

So that the shop manual can be of ample practical use, important safety and quality portions are marked with the following symbols.

Symbol	Item	Remarks
	Safety	Special safety precautions are necessary when performing the work.
	Caution	Special technical precautions or other precautions for preserving standards are necessary when performing the work.
	Weight	Weight of parts of systems. Caution necessary when selecting hoisting wire, or when working posture is important, etc.
	Tightening torque	Places that require special attention for the tightening torque during assembly.
	Coat	Places to be coated with adhesives and lubricants, etc.
	Oil, water	Places where oil, water or fuel must be added, and the capacity.
	Drain	Places where oil or water must be drained, and quantity to be drained.

## REMOVAL OF STARTING MOTOR ASSEMBLY

**⚠** Disconnect the cable from the negative (-) terminal of the battery.

1. Open engine hood side cover and lock in position.
2. Disconnect wiring (1).
3. Remove connector (2) from clip and disconnect.
4. Remove starting motor assembly (3). ※ 1

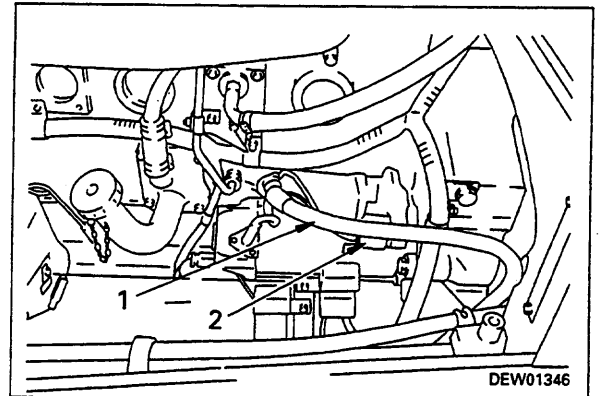

## INSTALLATION OF STARTING MOTOR ASSEMBLY

- Carry out installation in the reverse order of removal.

※ 1

- ★ When installing the starting motor assembly, install ground connection (4) securely.

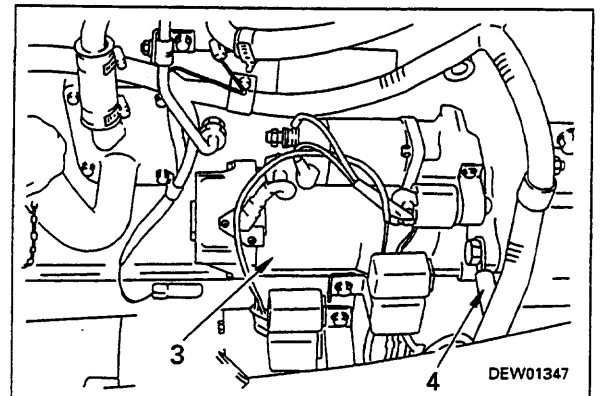

## REMOVAL OF ALTERNATOR ASSEMBLY

**⚠** Disconnect the cable from the negative (-) terminal of the battery.

1. Open engine hood left side cover and lock in position.
2. Disconnect 3 set of wiring (1).  
★ Mark the wiring with tags to prevent mistakes when assembling.
3. Loosen mounting bolt and nut (2), and adjustment plate mounting bolt (3). ※ 1
4. Move alternator assembly (5) towards engine, then remove fan belt (4) from alternator assembly (5). ※ 2
5. Remove mount bolt and nut (2), and adjustment plate mounting bolt (3), then remove alternator assembly (5).

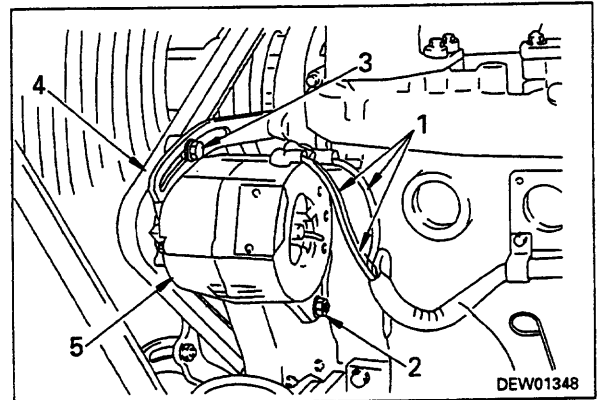

## INSTALLATION OF ALTERNATOR ASSEMBLY

- Carry out installation in the reverse order to removal.

※ 1

- ★ To prevent interference with the fan belt, set with the mount bolt and nut facing in the direction shown in the diagram on the right when installing.

※ 2

- ★ Adjust the belt tension. For details, see TESTING AND ADJUSTING, Testing and adjusting fan belt tension.

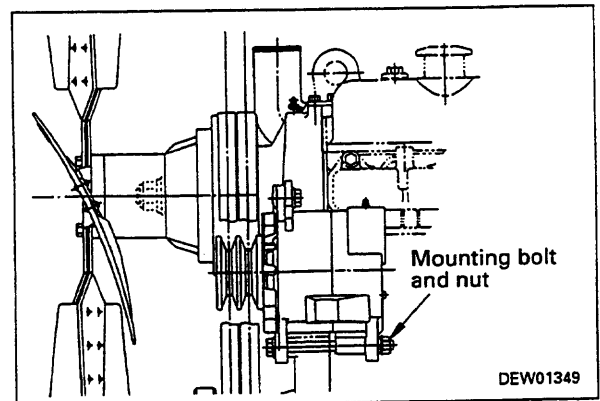



## REMOVAL OF ENGINE OIL COOLER ASSEMBLY

1. Drain coolant and lift off engine hood assembly.
2. Remove fuel injection pump assembly (1).  
For details, see REMOVAL OF FUEL INJECTION PUMP ASSEMBLY.
3. Remove tube (2) between corrosion resistor and oil cooler.
4. Remove engine oil filter head assembly (3) together with tube (4).
5. Remove cooler pipe (5), then remove oil cooler assembly (6).
6. Remove 4 nuts (7) from oil cooler assembly (6), then remove core (8).

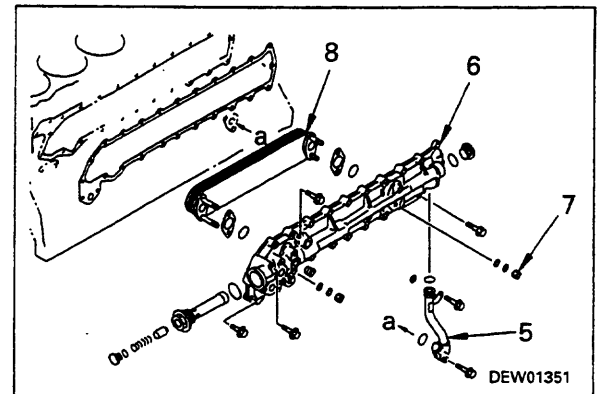
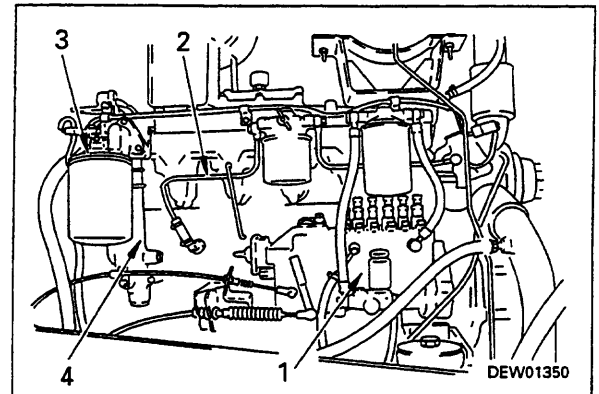

## INSTALLATION OF ENGINE OIL COOLER ASSEMBLY

- Carry out installation in the reverse order to removal.
- **Refilling with water**  
Add water through the water filler to the specified level. Run the engine to circulate the water through the system. Then check the water level again.

## REMOVAL OF AFTERCOOLER CORE ASSEMBLY

1. Drain coolant.
2. Remove air cleaner assembly (1) and remove bracket (2).
3. Disconnect muffler drain tube (3) and remove muffler assembly (4).
4. Disconnect deaeration hose (5).
5. Disconnect water temperature sensor wiring (6).
6. Remove fuel filter (7) and keep it offset toward chassis.
7. Remove corrosion resistor (8).
8. Remove bracket (9).
9. Remove intake connector (10).
10. Disconnect wirings and electrical intake air heater (11).
11. Disconnect connector (12) and remove after-cooler cover (13). ※ 1
12. Disconnect connector (14) and remove aftercooler core assembly (15).

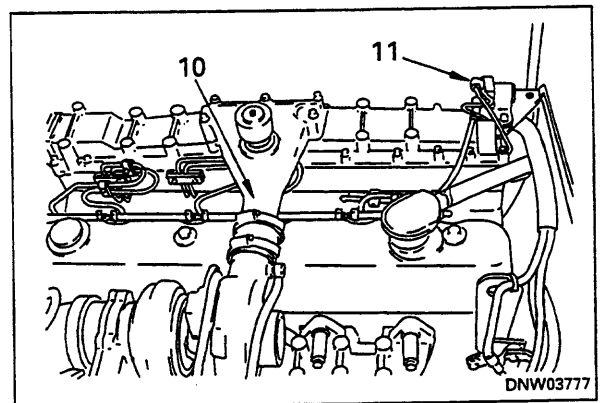
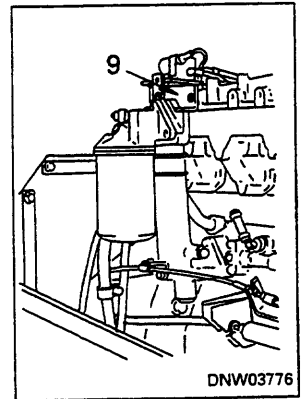
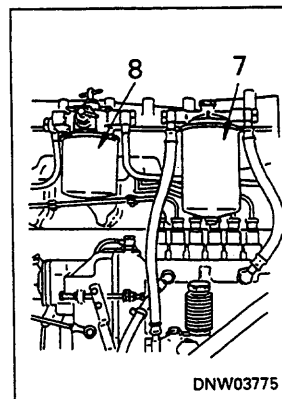
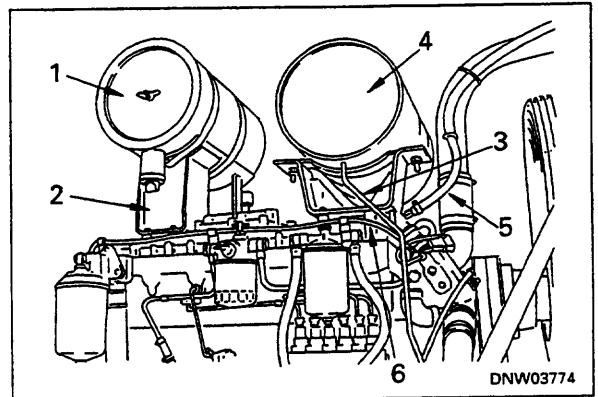

## INSTALLATION OF AFTERCOOLER CORE ASSEMBLY

- Carry out installation in the reverse order to removal.

※ 1

**Aftercooler cover installation bolt:**  
 $24.5 \pm 9.8 \text{ Nm}$  ( $2.5 \pm 1.0 \text{ kgm}$ )

- **Add coolant**
  - ★ Add coolant to the specified level, start the engine and circulate coolant. Check coolant level again.

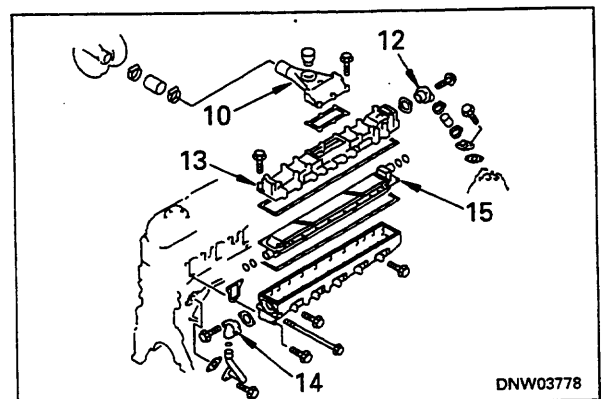

## REMOVAL OF FUEL INJECTION PUMP ASSEMBLY

1. Remove fuel filter assembly (1).
  - ★ Disconnect fuel hoses (2) and (3) at injection pump end, and remove together with filter assembly.
2. Disconnect fuel hoses (4) and (5). ※ 1
3. Disconnect stop motor cable (6) and accelerator control cable (7).
  - ★ Remove accelerator control cable (7) together with mounting bracket (8).
4. Remove boost compensator tube (9) and lubrication tube (10).
5. Remove clamps (11) and (12) of No. 1, 2, 3, and 4 fuel injection pipes.
6. Remove clamp (13) of No. 5 and 6 fuel injection pipes, and loosen tube clamps ①, ②, ③, and ④.
7. Disconnect 6 fuel injection pipes (14) from injection pump. ※ 2

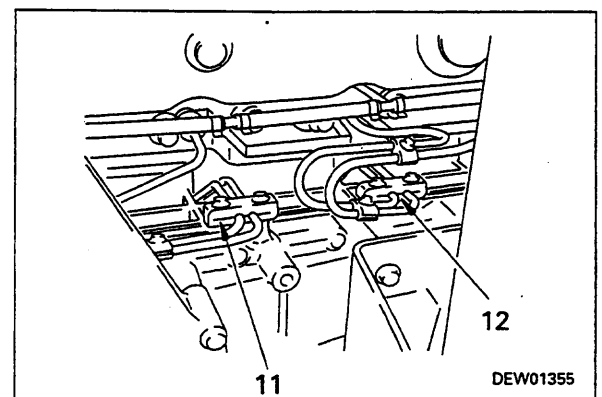
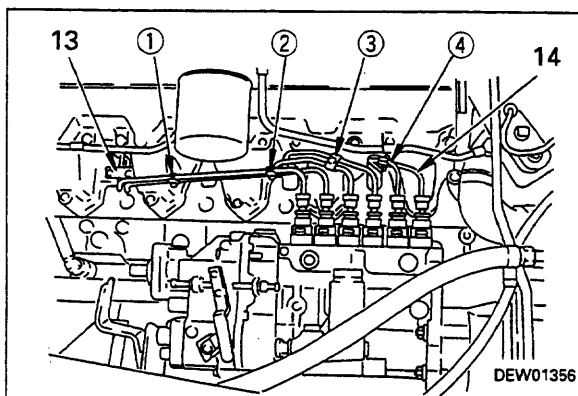
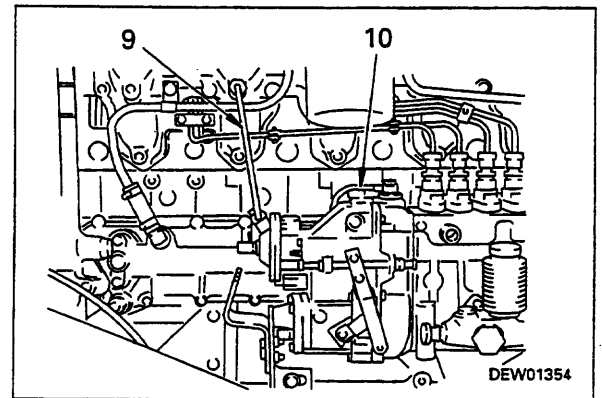
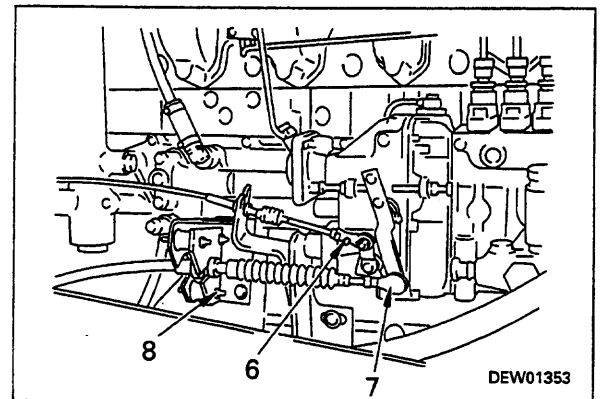
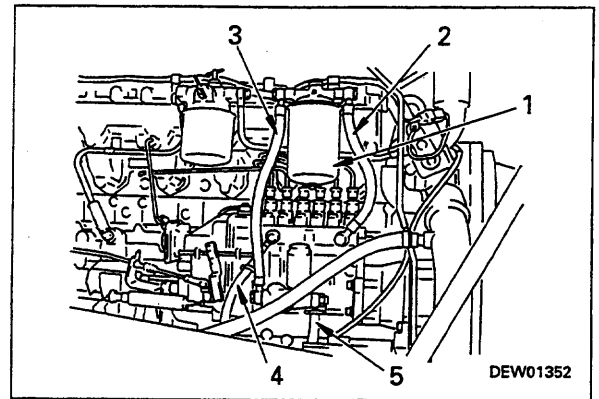

8. Remove mounting bracket (15) at rear of fuel injection pump.

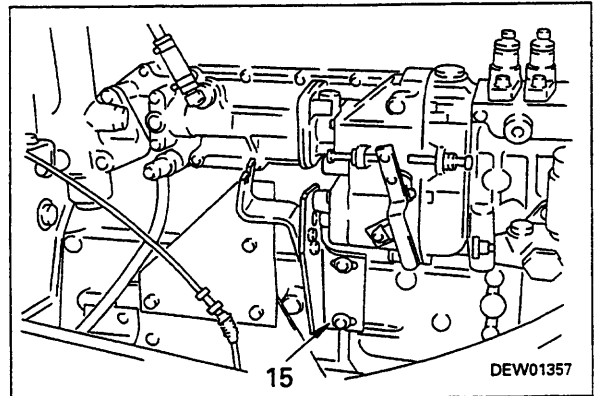

9. Remove mounting nut (16), then remove fuel injection pump assembly (17). ※ 3

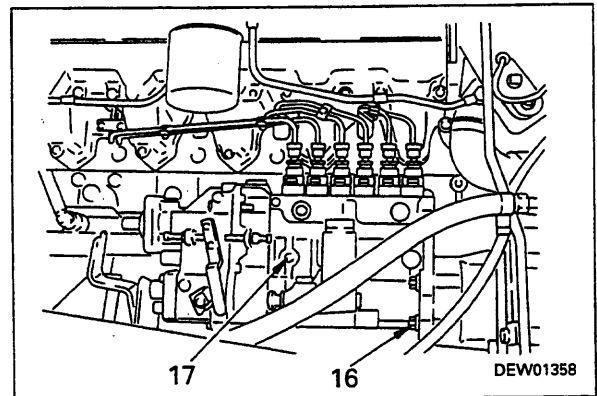

## INSTALLATION OF FUEL INJECTION PUMP ASSEMBLY

- Carry out installation in the reverse order to removal.

※ 1

 **kgm** Joint bolt:  $29.4 \pm 5 \text{ Nm}$  ( $3.0 \pm 0.5 \text{ kgm}$ )

※ 2

 **kgm** Fuel injection pipe sleeve nut:  
 $22.6 \pm 3 \text{ Nm}$  ( $2.3 \pm 0.3 \text{ kgm}$ )

※ 3

 **kgm** Injection pump mounting bolt:  
 $66.7 \pm 7.9 \text{ Nm}$  ( $6.8 \pm 0.8 \text{ kgm}$ )

- ★ Adjust the injection timing.  
For details, see TESTING AND ADJUSTING,  
Testing and adjusting fuel injection timing.

## REMOVAL OF WATER PUMP ASSEMBLY

1. Drain engine coolant.
2. Remove radiator upper tubes (1) and (2), then remove fan guard (3).
3. Remove water temperature sensor connector (4) from clip and disconnect, then remove spill hose (5).
4. Loosen adjustment bolt (7) and mount bolt (8) of alternator assembly (6), remove belt (9), then remove adjustment bolt (7), and move alternator assembly (6) towards frame. ※ 1
5. Remove fan (10) and spacer (11).
6. Remove thermostat housing (12).
7. Loosen clamp and move hose (13) towards tube, then remove mounting bolts, and lift off water pump assembly (14).

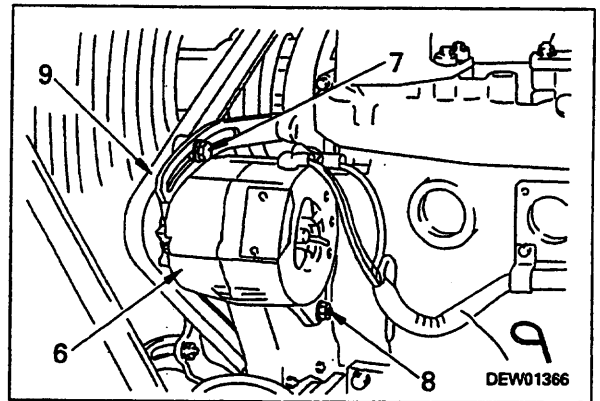
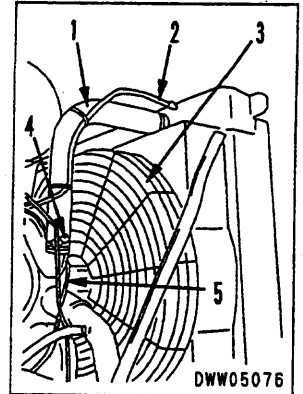

## INSTALLATION OF WATER PUMP ASSEMBLY

- Carry out installation in the reverse order to removal.

※ 1

- ★ Adjust the belt tension. For details, see TESTING AND ADJUSTING, Testing and adjusting fan belt tension.

- **Refilling with water**  
Add water through the water filler to the specified level. Run the engine to circulate the water through the system. Then check the water level again.

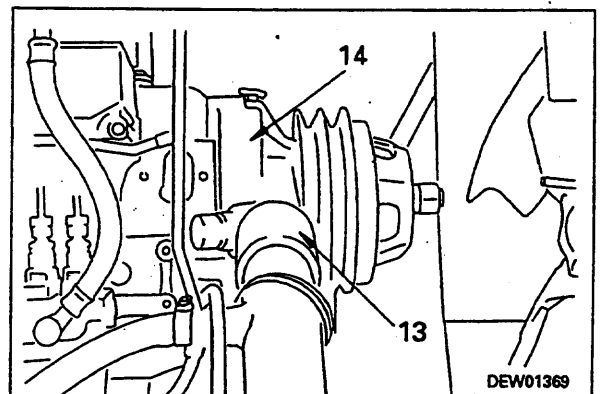
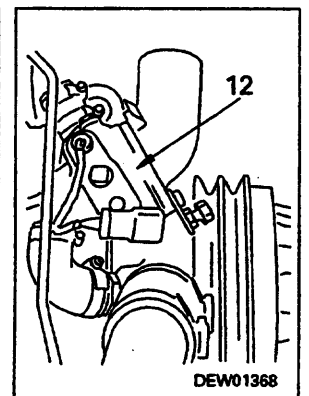
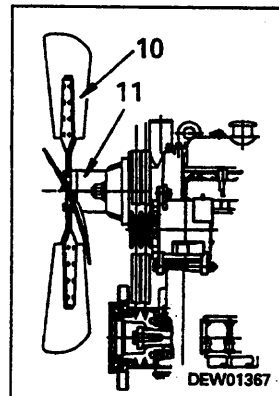

## REMOVAL OF TURBOCHARGER ASSEMBLY

1. Lift off engine hood assembly.
2. Remove intake hose (1). ※ 1
3. Remove muffler (2) together with bracket.
4. Remove intake connector (3).
5. Remove exhaust pipe elbow (4).
6. Remove turbocharger lubrication inlet tube (5) and return tube (6).
7. Remove turbocharger assembly (7). ※ 2

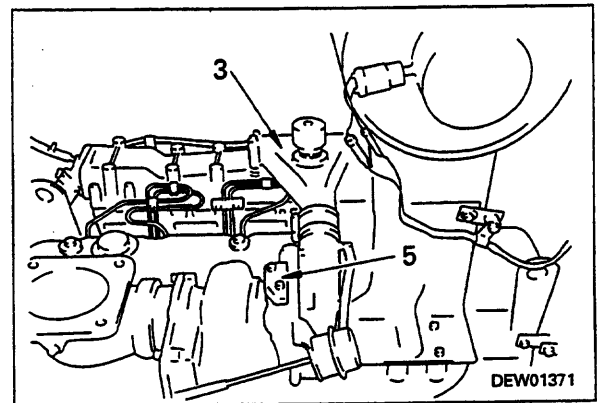
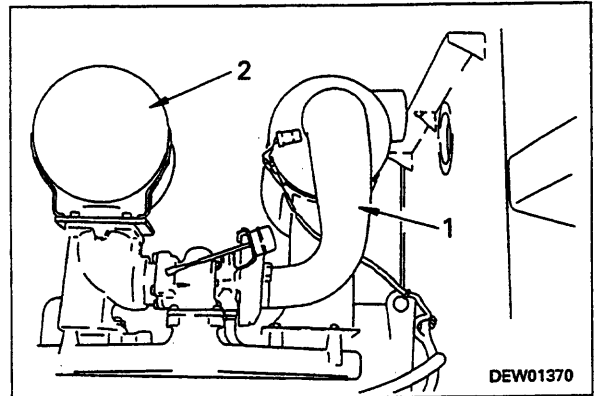

## INSTALLATION OF TURBOCHARGER ASSEMBLY

- Carry out installation in the reverse order to removal.

※ 1

**kgm** Intake hose clamp:  
 $8.8 \pm 0.5 \text{ Nm}$  ( $0.9 \pm 0.05 \text{ kgm}$ )

- ★ Insert intake hose (1) until it contacts the turbocharger flange.

※ 2

**kgm** Turbocharger mounting bolt:  
 $37.3 \pm 7.9 \text{ Nm}$  ( $3.8 \pm 0.8 \text{ kgm}$ )

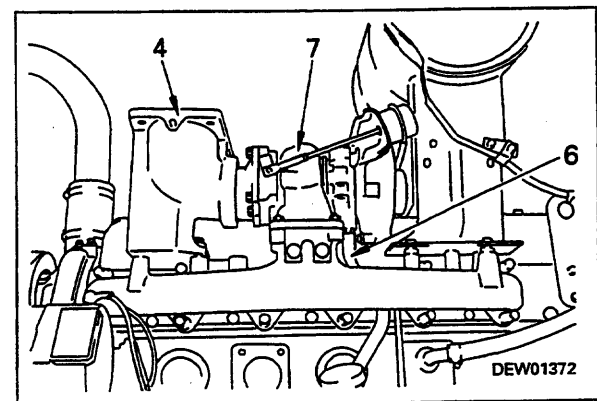

## REMOVAL OF NOZZLE HOLDER ASSEMBLY

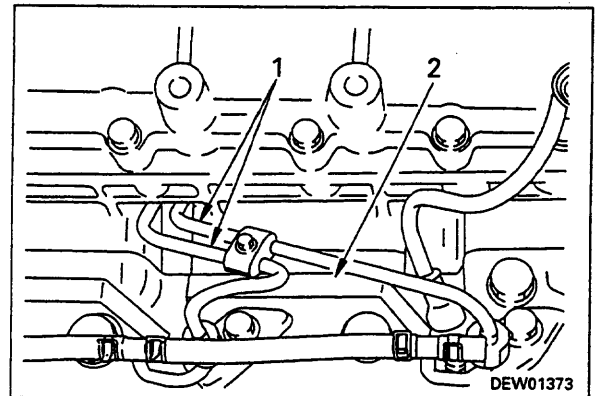

1. Lift off engine hood assembly.
2. Remove intake connector.
  - ★ Remove the intake connector only when removing the No. 4 nozzle holder assembly.
3. Remove fuel injection pipe (1) and lead (2). ※ 1
4. Remove holder (3). ※ 2
5. Remove spill hose (4), then remove nozzle (5).



## INSTALLATION OF NOZZLE HOLDER ASSEMBLY

- Carry out installation in the reverse order to removal.

※ 1

-  Fuel injection pipe sleeve nut:  
 $22.6 \pm 3 \text{ Nm}$  ( $2.3 \pm 0.3 \text{ kgm}$ )
-  Lead mounting nut:  
 $1.5 \pm 0.5 \text{ Nm}$  ( $0.15 \pm 0.05 \text{ kgm}$ )

※ 2

-  Holder mounting bolt:  
 $44.1 \pm 5 \text{ Nm}$  ( $4.5 \pm 0.5 \text{ kgm}$ )

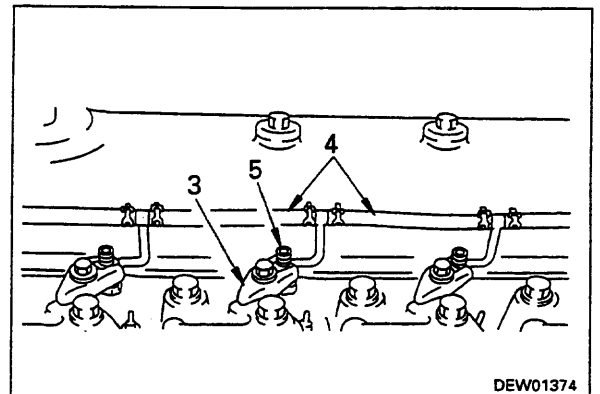

DEW01374

## REMOVAL OF THERMOSTAT ASSEMBLY

1. Open engine hood side cover.
2. Drain engine coolant.
3. Remove connector (1) from clip and disconnect.
4. Remove cover (2). ※ 1  
★ Do not disconnect the hose.
5. Remove thermostat (3).

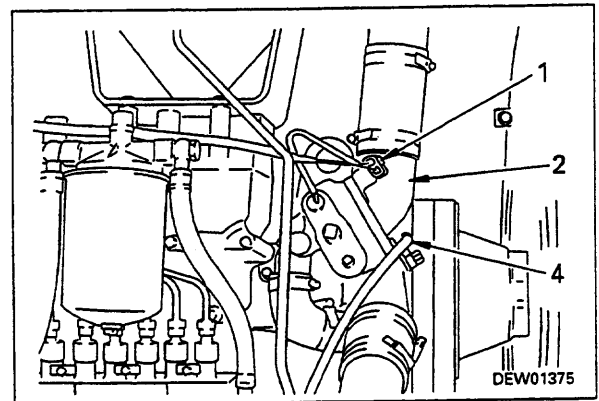

## INSTALLATION OF THERMOSTAT ASSEMBLY

- Carry out installation in the reverse order to removal.

※ 1

Clamp spill hose (4) securely.

- **Refilling with water**  
Add water through the water filler to the specified level. Run the engine to circulate the water through the system. Then check the water level again.

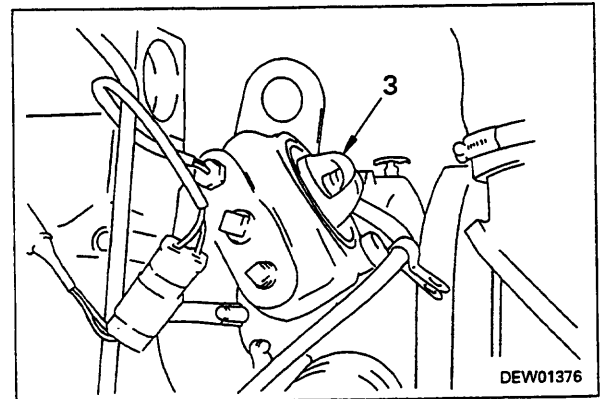



## REMOVAL OF CYLINDER HEAD ASSEMBLY

1. Lift off engine hood assembly.
2. Drain engine coolant.
3. Remove radiator upper tank tube (1) and hose (2).
4. Remove muffler assembly (3) together with bracket.
5. Disconnect 2 dust indicator wires (4), then disconnect clamp from air cleaner bracket.
6. Remove intake hose (5), then remove air cleaner assembly (6) together with bracket. ※ 1
7. Remove intake connector (7).
8. Disconnect wiring harness clamp (8).

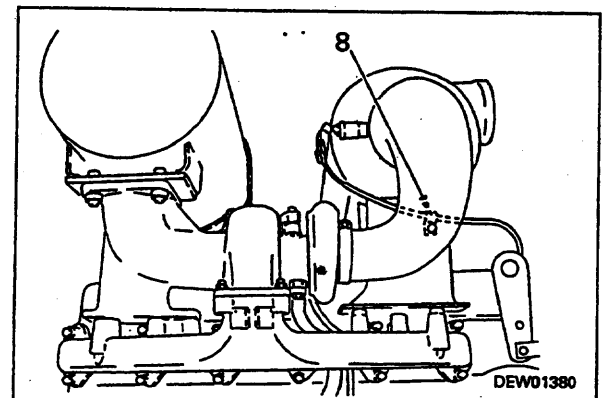
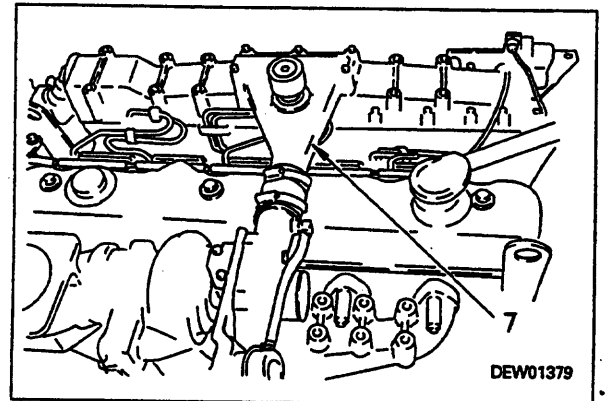
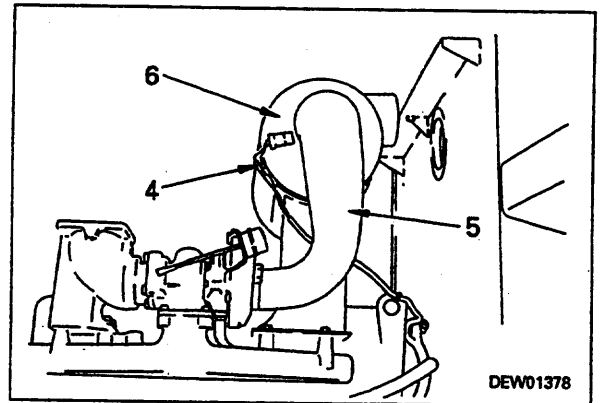
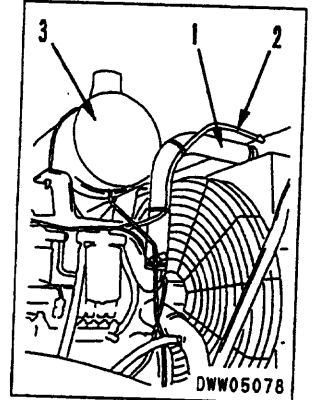

9. Remove lubrication inlet tube (9) and return tube (10), then lift off turbocharger and exhaust manifold assembly (11).

★ Turbocharger lubrication return tube (10) cannot be removed from the exhaust manifold, so remove it when the turbocharger and exhaust manifold assembly is disconnected.

※ 2

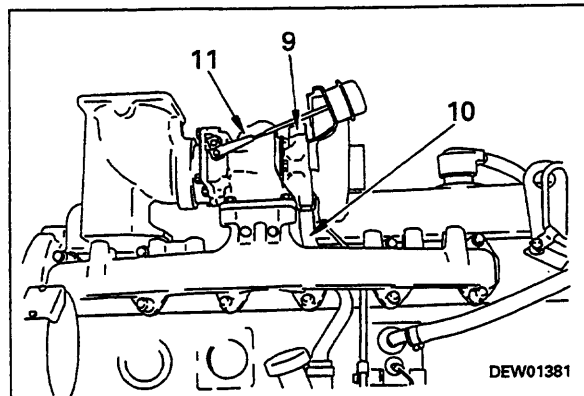

10. Remove water pump mounting bracket (12), and disconnect fuel return tube (13).

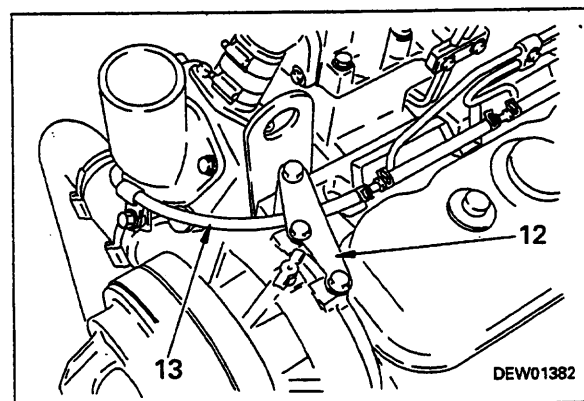

11. Disconnect engine oil pressure sensor wiring (14).

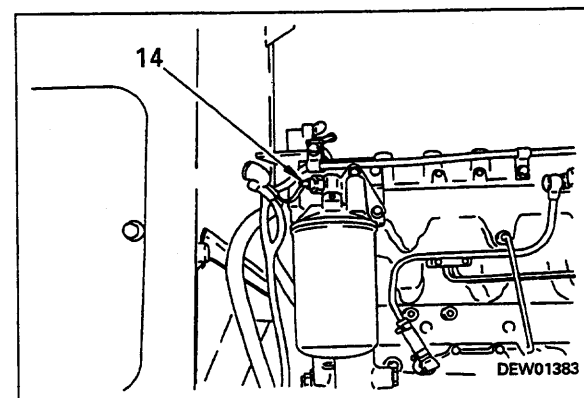

12. Remove water temperature sensor connector (15) from clip and disconnect, then disconnect wiring harness (16) from after-cooler assembly.

13. Remove fuel filter assembly (17) together with bracket, and move towards top of chassis frame.  
★ Do not disconnect the filter mount hose.

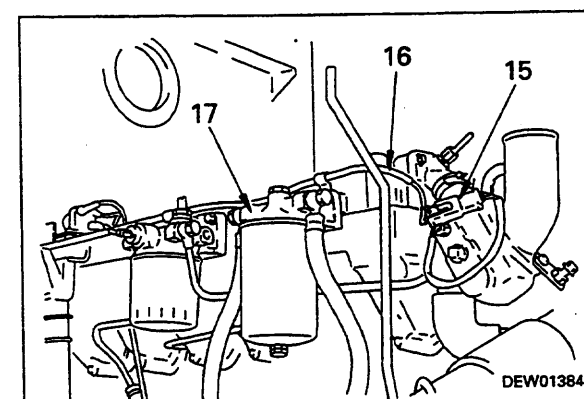

14. Remove boost compensation tube (18) and corrosion resistor tubes (19) and (20), then remove corrosion resistor assembly (21).
15. Remove connector (22) between after-cooler and thermostat housing, then loosen clamp of hose (23) and remove thermostat housing (24).

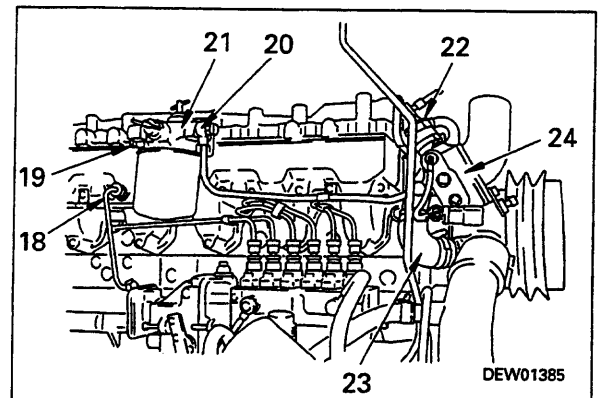

16. Remove cable clamp of stop motor cable (25), then remove engine oil filter assembly (26) and tube (27).

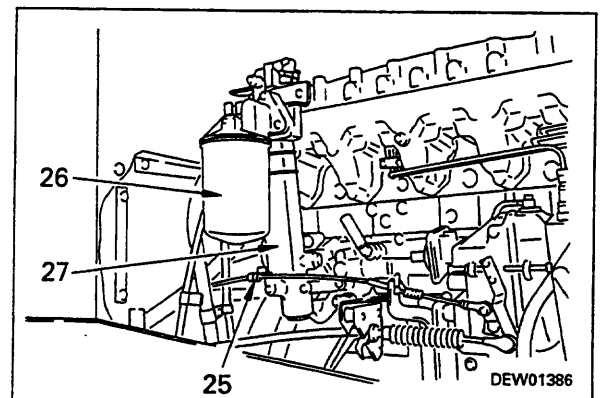

17. Remove heater relay connector (28) from clip and disconnect, then disconnect wiring (29) and (30).

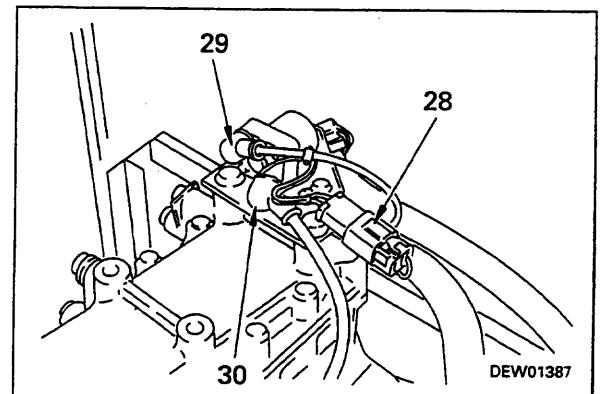

18. Disconnect No. 4, 5, and 6 fuel injection pipes (31).

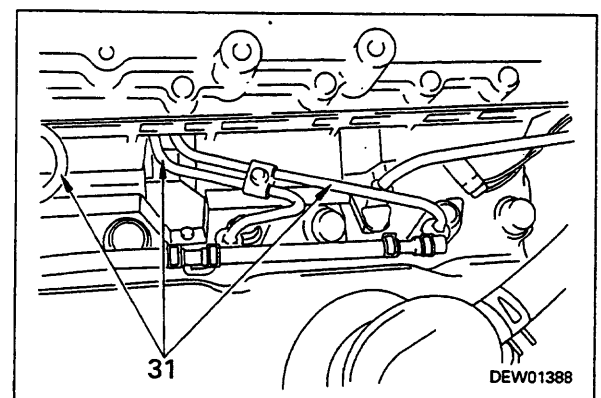

19. Remove tube clamps (32) and (33), and disconnect No. 1, 2, and 3 fuel injection pipes (34).

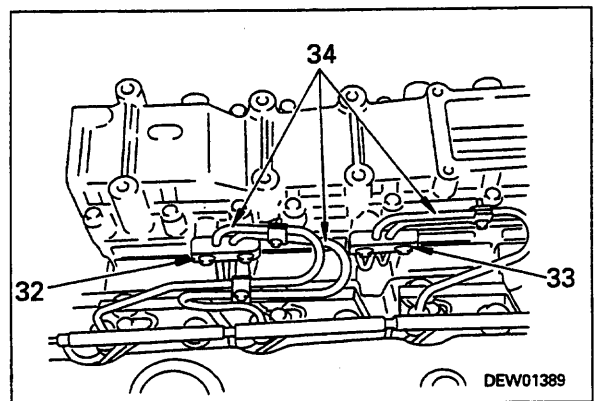

20. Remove No. 5 and 6 tube clamps (35), and lift off after-cooler assembly (36). ※ 3

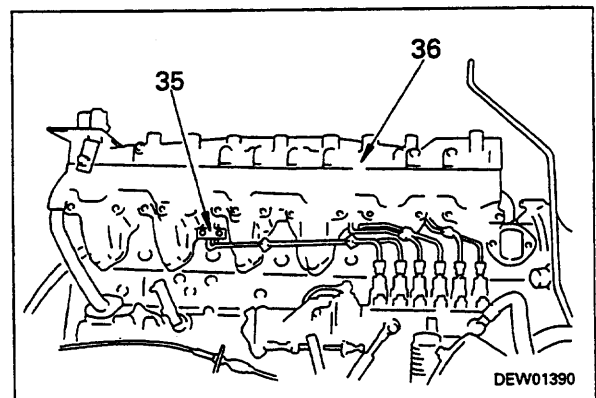

21. Remove fuel injection pipes (31) and (34). ※ 4

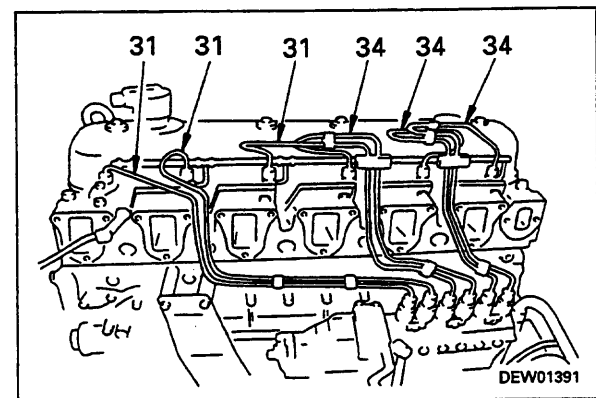

22. Remove 5 leads (37). ※ 5

※ 5

23. Remove 6 holders (38). ※ 6

※ 6

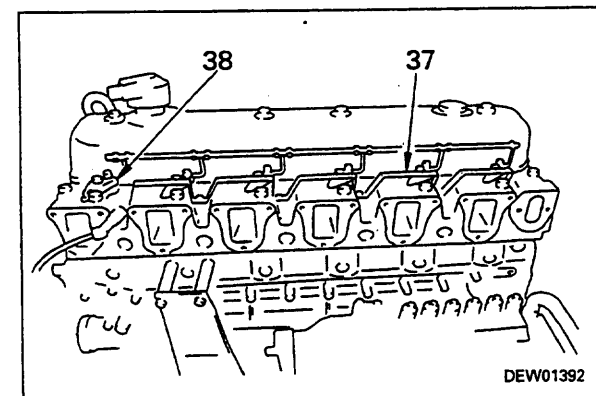

24. Remove spill hoses (39) and nozzles (40).  
★ Spill hoses: 5, nozzles: 6

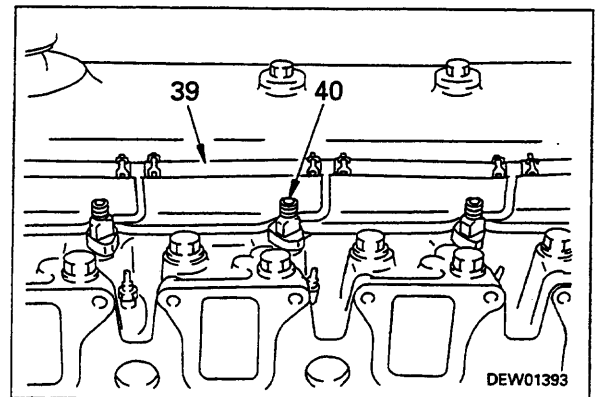

25. Remove head cover (41).

※ 7

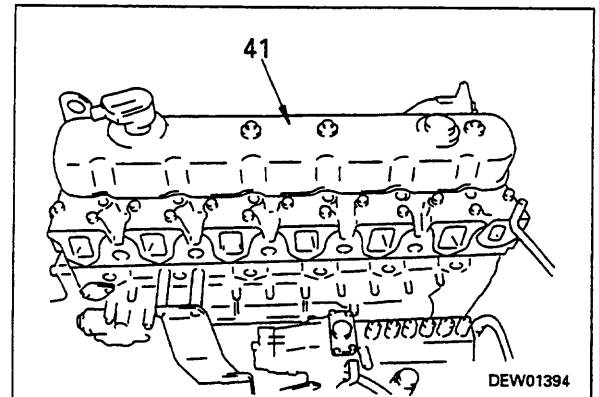

26. Remove rocker arm assembly (42).  
★ Loosen the locknut, then loosen the adjustment screw 2 - 3 turns.

※ 8

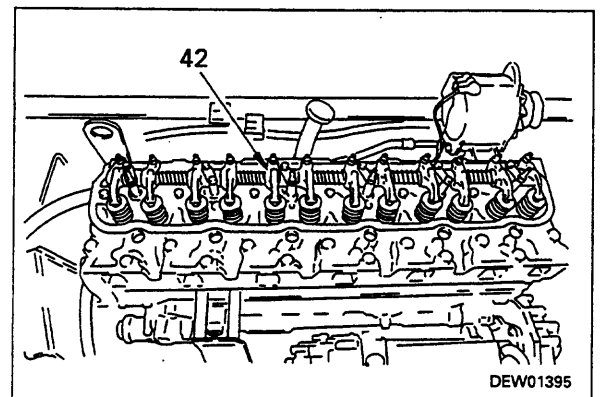

27. Remove 12 push rods (43).

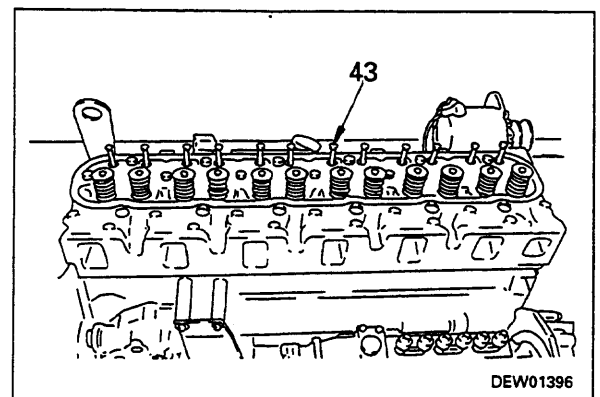

28. Remove cylinder head assembly (44).

※ 9

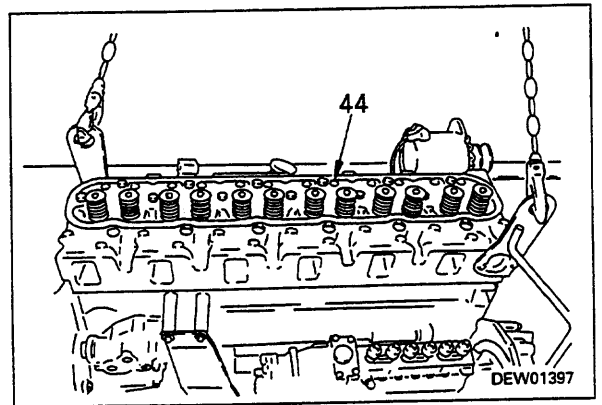



**Download the full PDF manual instantly.**

**Our customer service e-mail:**

**[aservicemanualpdf@yahoo.com](mailto:aservicemanualpdf@yahoo.com)**