

Shop Manual

WHEEL LOADER

WA200 -6

WA200PZ-6

SERIAL NUMBERS

WA200- 70001

WA200PZ- 70001

and up

ecot3

KOMATSU

Table of contents

00 Index and foreword	
100 Index	SEN05291-03
Composition of shop manual.....	2
Table of contents.....	4
200 Foreword and general information	SEN05292-00
Safety notice.....	2
How to read the shop manual.....	7
Explanation of terms for maintenance standard.....	9
Handling of electric equipment and hydraulic component.....	11
Handling of connectors newly used for engines.....	20
How to read electric wire code.....	23
Precautions when carrying out operation.....	26
Method of disassembling and connecting push-pull type coupler.....	29
Standard tightening torque table.....	32
Conversion table.....	36
01 Specification	
100 Specification and technical data	SEN05293-00
Specification dimension drawing.....	3
Specifications.....	4
Weight table.....	8
Table of fuel, coolant and lubricants.....	10
10 Structure, function and maintenance standard	
100 Engine and cooling system	SEN05294-01
Engine mount and transfer mount.....	2
Damper.....	3
Cooling system.....	4
Cooling system hydraulic piping diagram.....	5
Cooling fan motor.....	7
200 Power train	SEN05295-00
Power train.....	3
Power train system diagram.....	4
Drive shaft.....	6
HST hydraulic piping diagram.....	7
HST pump.....	8
HST motor.....	16
Transfer.....	22
Clutch solenoid valve.....	33
Axle.....	34
Differential.....	36
Torque proportioning differential.....	41
Limited slip differential.....	44
Final drive.....	48
300 Steering system	SEN05296-00
Steering piping diagram.....	3
Steering column.....	4
Priority valve.....	5
Orbit-roll valve.....	8
2-way restrictor valve.....	16
Cushion valve.....	17
Steering cylinder.....	18
Emergency steering piping diagram.....	20
Emergency steering valve.....	21
Steering relief valve.....	24

400 Brake system	SEN05297-00
Brake piping diagram.....	3
Charge valve	4
Brake valve.....	8
Inching valve.....	12
Accumulator (for brake)	13
Slack adjuster	14
Brake	16
Parking brake control.....	21
Parking brake	22
500 Undercarriage and frame	SEN05298-00
Axle mount and center hinge pin	2
Tires.....	7
600 Hydraulic system	SEN05299-00
Work equipment hydraulic piping diagram	2
Work equipment control lever linkage	6
Hydraulic tank.....	10
4-gear pump	12
Work equipment control valve	15
PPC valve.....	39
Lock valve.....	54
Accumulator (for PPC circuit)	55
Bypass valve	56
Quick coupler solenoid valve.....	59
ECSS valve	60
Accumulator (for ECSS)	62
700 Work equipment	SEN05300-00
Work equipment linkage	2
Bucket.....	6
Bucket positioner and boom kick-out.....	10
Work equipment cylinder	23
800 Cab and its attachments	SEN05301-00
Cab.....	3
Air conditioner.....	4
901 Electrical system, Part 1	SEN05302-00
Machine monitor system.....	2
Machine monitor	6
902 Electrical system, Part 2	SEN05303-00
Electrical system (HST controller system).....	2
HST controller.....	18
ECSS system	20
KOMTRAX system	22
Engine starting circuit	24
Engine stopping circuit	26
Preheating circuit.....	27
Engine output derating function.....	28
Automatic warm-up function	28
Parking brake circuit.....	30
Coupler plunger control system.....	32
Max. traction switch	33
Multi-function knob	34
Sensor	35
20 Standard value table	
100 Standard service value table	SEN05304-00
Standard service value table for engine	2
Standard service value table for chassis	3

30 Testing and adjusting	
101 Testing and adjusting, Part 1	SEN05305-00
Tools for testing, adjusting, and troubleshooting	2
Sketches of special tools.....	7
Measuring engine speed.....	8
Measuring exhaust gas color	10
Adjusting valve clearance	11
Measuring compression pressure	13
Measuring blow-by pressure	16
Testing engine oil pressure	17
Measuring intake air (boost) pressure.....	18
Handling fuel system equipment.....	20
Releasing residual pressure in fuel system.....	20
Measuring fuel pressure.....	21
Measuring fuel return rate and leakage	23
Bleeding air from fuel circuit.....	27
Checking leakage in fuel system.....	28
Handling cylinder cut-out mode operation.....	29
Handling no-injection cranking operation	29
Handling controller voltage circuit	30
Check of muffler and muffler stack for looseness and damage	30
Check of muffler function	31
Check of installed condition of cylinder head and manifolds.....	31
Check of engine piping for damage and looseness	32
Testing and adjusting air conditioner compressor belt tension.....	32
Replacing alternator belt	33
102 Testing and adjusting, Part 2	SEN05306-01
Checking operating force of accelerator pedal.....	3
Checking directional lever	4
Testing and adjusting HST oil pressure.....	5
Testing clutch control pressure.....	9
Testing and adjusting steering wheel	10
Testing and adjusting steering oil pressure	12
Bleeding air from steering circuit.....	14
Testing hydraulic fan	15
Measuring brake pedal.....	17
Testing and adjusting brake pedal linkage	18
Measuring brake performance	19
Testing and adjusting accumulator charge pressure.....	20
Testing wheel brake oil pressure.....	22
Testing wear of brake disc.....	25
Bleeding air from wheel brake circuit	26
Releasing residual pressure in brake accumulator circuit.....	27
Testing parking brake performance.....	28
Testing and adjusting parking brake control cable	29
Measuring and adjusting work equipment control lever	30
Testing and adjusting work equipment hydraulic pressure.....	31
Testing work equipment PPC oil pressure	32
Bleeding air from hydraulic circuit	34
Releasing remaining pressure in hydraulic circuit.....	35
Testing and adjusting bucket positioner	36
Testing and adjusting boom kick-out switch	38
Checking proximity switch operation pilot lamp	39
Procedure for testing diodes	40
Preparation work for troubleshooting for electric system	42
Starting KOMTRAX terminal operations.....	46
Indicator lamps of KOMTRAX terminal	50

103 Testing and adjusting, Part 3	SEN05307-01
Adjusting machine monitor	2
Adjusting replaced, reassembled or added sensor, controller, etc. with machine monitor	3
Special functions of machine monitor (EMMS).....	5
Pm clinic inspection chart	59
40 Troubleshooting	
100 Failure code table and fuse locations	SEN05308-00
Failure codes table	2
Fuse locations	8
200 General information on troubleshooting	SEN05309-00
Points to remember when troubleshooting	2
Sequence of events in troubleshooting	3
Testing before troubleshooting	4
Classification and procedures of troubleshooting.....	5
Information contained in troubleshooting table.....	8
Connection table for connector pin numbers.....	10
T- branch box and T- branch adapter table	46
301 Troubleshooting by failure code (Display of code), Part 1	SEN05310-00
Failure code [2G40ZG] Brake: Oil pressure reduction	2
Failure code [6091NX] HST filter: Clogging.....	4
Failure code [989FN1] Travel speed: Overrun alarm	5
Failure code [AB00L6] Alternator R system: Hot short.....	6
Failure code [AB00MA] Alternator R system: Ground fault/Disconnection /Low charge voltage	8
Failure code [B@BAZG] Engine: Oil pressure reduction.....	10
Failure code [B@BCNS] Engine: Overheat.....	11
Failure code [B@BCZK] Engine: Low coolant level	12
Failure code [B@C6NS] Front brake: High oil temperature	14
Failure code [B@CRNS] HST: High oil temperature	15
302 Troubleshooting by failure code (Display of code), Part 2	SEN05311-00
Failure code [CA111] Abnormality in engine controller	3
Failure code [CA115] Engine Ne or Bkup speed sensor error.....	4
Failure code [CA122] Charge pressure sensor high error.....	6
Failure code [CA123] Charge pressure sensor low error	8
Failure code [CA131] Throttle sensor high error	10
Failure code [CA132] Throttle sensor low error.....	12
Failure code [CA144] Coolant sensor high error	14
Failure code [CA145] Coolant sensor low error.....	16
Failure code [CA153] Charge temperature sensor high error	18
Failure code [CA154] Charge temperature sensor low error.....	20
Failure code [CA155] Derating of speed by abnormally high charge temperature.....	22
Failure code [CA187] Sensor power supply 2 low error	24
Failure code [CA221] Atmospheric pressure sensor high error.....	26
Failure code [CA222] Atmospheric sensor low error	28
Failure code [CA227] Sensor power supply 2 high error.....	30
Failure code [CA234] Engine overspeed.....	31
Failure code [CA238] Ne speed sensor power supply error.....	32
Failure code [CA271] IMV (IMA) Short circuit.....	33
Failure code [CA272] IMV (IMA) Disconnection	34
Failure code [CA322] Injector #1 open/short error	36
Failure code [CA324] Injector #3 open/short error	38
Failure code [CA331] Injector #2 open/short error	40
Failure code [CA332] Injector #4 open/short error	42
Failure code [CA342] Calibration code inconsistency	44
Failure code [CA351] Injectors drive circuit error	46
Failure code [CA352] Sensor power supply 1 low error	48
Failure code [CA386] Sensor power supply 1 high error.....	50

303 Troubleshooting by failure code (Display of code), Part 3	SEN05312-00
Failure code [CA428] Abnormally high level in water sensor	4
Failure code [CA429] Abnormally low level in water sensor	6
Failure code [CA431] Idle validation switch error	8
Failure code [CA432] Idle validation action error	12
Failure code [CA435] Engine oil pressure switch error	16
Failure code [CA441] Battery voltage low error	17
Failure code [CA442] Battery voltage high error	20
Failure code [CA449] Common rail pressure high error 2.....	22
Failure code [CA451] Common rail pressure sensor high error.....	24
Failure code [CA452] Common rail pressure sensor low error	26
Failure code [CA488] Derating of torque by abnormally high charge temperature	28
Failure code [CA553] Common rail pressure high error 1.....	29
Failure code [CA559] Supply pump pressure very low error.....	30
Failure code [CA689] Engine Ne speed sensor error	32
Failure code [CA731] Engine Bkup speed sensor phase error	34
Failure code [CA757] All continuous data lost error.....	35
Failure code [CA778] Engine Bkup speed sensor error.....	38
Failure code [CA1633] KOMNET datalink timeout error	40
Failure code [CA2185] Throttle sensor supply voltage high error	42
Failure code [CA2186] Throttle sensor power supply low error	44
Failure code [CA2249] Supply pump pressure very low error 2.....	46
Failure code [CA2311] Abnormality in IMV (IMA) solenoid	48
Failure code [CA2555] Intake heater relay disconnection error	50
Failure code [CA2556] Intake heater relay short circuit error.....	52
304 Troubleshooting by failure code (Display of code), Part 4	SEN05313-00
Failure code [D160KY] Backup alarm/lamp relay 1 circuit: Hot short	2
Failure code [D192KY] ECSS solenoid relay: Hot short	4
Failure code [D1B0KA] HST safety relay: Disconnection	6
Failure code [D1B0KB] HST safety relay: Ground fault	8
Failure code [D1B0KY] HST safety relay: Hot short	10
Failure code [D5ZHL6] IGN C system: Ground fault/Disconnection	12
Failure code [DAF3KK] UNSW power supply: Ground fault/Disconnection.....	14
Failure code [DAFRKR] Machine monitor CAN-NET Signal: Disconnection	16
Failure code [DAJ0KK] HST controller power supply: Low voltage	18
Failure code [DAJ0KT] HST controller memory (EEPROM): Abnormality	20
Failure code [DAJ1L4] HST controller main power line: Disconnection/Ground fault.....	22
Failure code [DAJ1L6] HST controller main power line: Hot short.....	24
Failure code [DAJ2KK] Controller solenoid power supply: Low voltage	26
Failure code [DAJ2L3] HST controller load power supply holding line: Hot short in wiring harness.....	28
Failure code [DAJ2L4] HST controller load power supply holding line: Disconnection/Ground fault	30
Failure code [DAJ5KX] Sensor 5V power supply: Out of output range.....	32
Failure code [DAJ9KQ] HST controller model selection: Disagreement of model selection signals.....	34
Failure code [DAJRKR] HST controller CAN-NET signal: Disconnection	36
Failure code [DAJRMA] HST controller: Disagreement in option selection	41
305 Troubleshooting by failure code (Display of code), Part 5	SEN05314-00
Failure code [DB2RKR] Engine controller CAN-NET: Disconnection in signal line.....	2
Failure code [DD1NL4] Fan automatic reverse switch signal: Abnormality	8
Failure code [DD1NLD] Fan reverse switch signal: Abnormality	10
Failure code [DDB6KA] Parking brake reminder signal: Disconnection/Hot short.....	12
Failure code [DDB6KB] Parking brake indicator signal: Ground fault.....	14
Failure code [DDB6KZ] Parking brake switch (bottom switch) or parking brake reminder switch (intermediate switch): Trouble.....	16
Failure code [DDB6L0] Parking brake reminder signal: Ground fault	18
Failure code [DDB6L4] Parking brake indicator signal: Disconnection/Hot short	20
Failure code [DDD7KX] Travel speed control dial signal: Disconnection/Ground fault.....	22
Failure code [DDD7KY] Travel speed control dial signal: Hot short.....	24
Failure code [DDE5MA] Emergency steering operation switch: Disconnection.....	26

Failure code [DDK6KA] FNR lever: Disconnection/Ground fault	28
Failure code [DDK6KY] FNR lever: Hot short.....	32
Failure code [DDS5L6] Steering: Low oil pressure (Operation of emergency steering)	34
306 Troubleshooting by failure code (Display of code), Part 6	SEN05315-00
Failure code [DF10KA] Travel speed range selector switch: Disconnection/Ground fault	2
Failure code [DF10KB] Travel speed range selector switch: Hot short	6
Failure code [DGH1KX] HST oil temperature sensor: Ground fault	8
Failure code [DGR2KB] Brake oil temperature sensor: Ground fault.....	9
Failure code [DGR2KZ] Brake oil temperature sensor: Disconnection/Hot short.....	10
Failure code [DHH1KX] HST oil pressure sensor: Disconnection/Ground fault	12
Failure code [DHH1KY] HST oil pressure sensor: Hot short	14
Failure code [DHTCL6] HST filter clogging sensor: Functional defect	16
Failure code [DJF1KA] Fuel level sensor: Disconnection/Hot short	18
Failure code [DLT3KX] Travel speed sensor B: Abnormality.....	20
Failure code [DLT4KX] Travel speed sensor A: Abnormality.....	24
Failure code [DLT4LC] Travel speed sensor A & B: Abnormality	26
Failure code [DV00KY] Alarm buzzer: Hot short	28
Failure code [DW26KA] Motor 2 solenoid: Disconnection/Ground fault	30
Failure code [DW26KY] Motor 2 solenoid: Hot short.....	32
Failure code [DW7BKY] Fan reverse solenoid circuit: Hot short	34
Failure code [DW7BKZ] Fan reverse solenoid circuit: Disconnection/Ground fault	36
307 Troubleshooting by failure code (Display of code), Part 7	SEN05316-00
Failure code [DX16KA] Fan EPC solenoid: Disconnection	2
Failure code [DX16KB] Fan EPC solenoid: Ground fault	3
Failure code [DX16KY] Fan EPC solenoid: Hot short	4
Failure code [DX19KA] Motor 1 solenoid: Disconnection.....	6
Failure code [DX19KB] Motor 1 solenoid: Ground fault.....	8
Failure code [DX19KY] Motor 1 solenoid: Hot short.....	10
Failure code [DX20KA] Clutch EPC solenoid: Disconnection	12
Failure code [DX20KB] Clutch EPC solenoid: Ground fault	14
Failure code [DX20KY] Clutch EPC solenoid: Hot short	16
Failure code [DXH7KB] Reverse solenoid: Ground fault.....	18
Failure code [DXH7KZ] Reverse solenoid: Disconnection/Hot short.....	20
Failure code [DXH8KB] Forward solenoid: Ground fault.....	22
Failure code [DXH8KZ] Forward solenoid: Disconnection/Hot short.....	24
Failure code [J141N1] Steering pump: Overrun alarm	26
Failure code [M100N1] HST pump: Overrun alarm	27
Failure code [M400N1] Motor 1: Overrun alarm	28
400 Troubleshooting of electrical system (E-mode)	SEN05317-00
E-1 Engine does not start	3
E-2 Preheater does not operate normally.....	10
E-3 Travel speed is low or high	14
E-4 ECSS does not operate	20
E-5 ECSS keeps operating.....	23
E-6 Defective boom kick-out function and cancellation	26
E-7 Defective bucket positioner function and cancellation	30
E-8 Defective lift arm FLOATING holding function and cancellation	34
E-9 Travel direction selection system does not function.....	38
E-10 Fan does not reverse	42
E-11 Fan keeps rotating in reverse.....	46
E-12 Wiper does not operate.....	48
E-13 Windshield washer does not operate	52
E-14 Headlamp, clearance lamp and tail lamp do not light up or go off	56
E-15 Working lamp does not light up or go off.....	64
E-16 Turn signal lamp and hazard lamp do not light up or go off	69
E-17 Brake lamp does not light or it keeps lighting up	76
E-18 Backup lamp does not light or it keeps lighting up	78
E-19 Backup alarm does not sound or it keeps sounding	81

E-20	Horn does not sound or it keeps sounding	84
E-21	Alarm buzzer does not sound or it keeps sounding.....	86
E-22	Air conditioner does not operate or stop.....	89
E-23	The KOMTRAX system does not work properly	92
500	Troubleshooting of hydraulic and mechanical system (H-mode)	SEN05318-00
	Method of using troubleshooting chart	3
	Failure code and cause table	6
H-1	The machine does not start.....	8
H-2	The travel speed is slow	9
H-3	The traction force is weak	10
H-4	Engine stalls when traveling or engine speed drops excessively.....	11
H-5	Speed range is not shifted.....	12
H-6	The steering wheel does not turn	13
H-7	The steering wheel is heavy.....	14
H-8	Steering wheel shakes or jerks.....	15
H-9	Machine deviates naturally to one side when traveling	15
H-10	The brake does not work or does not work well	16
H-11	The brake is not released or is dragged	17
H-12	The lift arm does not rise or lower	18
H-13	The lift arm moves slowly or the lift arm rising force is insufficient	19
H-14	When rising, the lift arm comes to move slowly at specific height.....	20
H-15	The lift arm cylinder cannot hold down the bucket (The bucket rises in the air).....	20
H-16	Hydraulic drifts of the lift arm occur often	20
H-17	The lift arm wobbles during operation	20
H-18	When the control lever is switched from "HOLD" to "RAISE," the lift arm falls temporarily	21
H-19	The bucket does not tilt back.....	22
H-20	The bucket moves slowly or the tilting-back force is insufficient	23
H-21	The bucket comes to operate slowly in the midst of tilting-back	24
H-22	The bucket cylinder cannot hold down the bucket	24
H-23	Hydraulic drifts of the bucket occur often	24
H-24	The bucket wobbles during travel with load (The work equipment valve is set to "HOLD")	24
H-25	When the control lever is switched from "HOLD" to "TILT," the bucket falls temporarily	25
H-26	The control levers of the lift arm and bucket do not move smoothly and heavy.....	25
H-27	The ECSS does not operate and machine pitches and bounces.....	26
H-28	Fan revolution is abnormal (Fan sound/vibration is abnormally large or engine overheats)	27
600	Troubleshooting of engine (S-mode)	SEN05319-00
	Method of using troubleshooting charts	2
S-1	Starting performance is poor	6
S-2	Engine does not start.....	7
S-3	Engine does not pick up smoothly.....	10
S-4	Engine stops during operations	11
S-5	Engine does not rotate smoothly	12
S-6	Engine lacks output (or lacks power).....	13
S-7	Exhaust smoke is black (incomplete combustion)	14
S-8	Oil consumption is excessive (or exhaust smoke is blue)	15
S-9	Oil becomes contaminated quickly	16
S-10	Fuel consumption is excessive	17
S-11	Oil is in coolant (or coolant spurts back or coolant level goes down)	18
S-12	Oil pressure drops	19
S-13	Oil level rises (Entry of coolant or fuel).....	20
S-14	Coolant temperature becomes too high (overheating)	21
S-15	Abnormal noise is made	22
S-16	Vibration is excessive	23

50 Disassembly and assembly	
100 General information on disassembly and assembly	SEN05320-00
How to read this manual	2
Coating materials list	4
Special tool list	7
Sketches of special tools	11
200 Engine and cooling system	SEN05321-00
Removal and installation of fuel supply pump assembly	2
Removal and installation of fuel injector assembly	6
Removal and installation of cylinder head assembly	14
Removal and installation of engine hood assembly	27
Removal and installation of radiator	31
Removal and installation of air aftercooler	34
Removal and installation of hydraulic oil cooler assembly	36
Removal and installation of engine assembly	38
Removal and installation of engine front oil seal assembly	45
Removal and installation of engine rear oil seal assembly	48
Removal and installation of cooling fan and fan motor assembly	51
Removal and installation of fuel tank assembly	54
301 Power train, Part 1	SEN05322-00
Disassembly and assembly of transfer assembly	2
Removal and installation of parking brake assembly	21
Disassembly and assembly of parking brake assembly	23
302 Power train, Part 2	SEN05323-00
Removal and installation of front axle assembly	2
Removal and installation of rear axle assembly	4
Disassembly and assembly of axle housing assembly	7
Disassembly and assembly of differential assembly	15
400 Undercarriage and frame	SEN05324-00
Removal and installation of center hinge pin	2
Removal and installation of counterweight assembly	11
500 Hydraulic system	SEN05325-00
Removal and installation of HST pump and 4-gear pump assembly	2
Disassembly and assembly of HST pump assembly	6
Removal and installation of HST motor 1 assembly	33
Removal and installation of HST motor 2 assembly	35
Disassembly and assembly of HST motor assembly	37
Removal and installation of work equipment control valve assembly	53
Removal and installation of hydraulic tank	55
Disassembly and assembly of hydraulic cylinder assembly	57
600 Work equipment	SEN05326-00
Removal and installation of work equipment assembly	2
700 Cab and its attachments	SEN05327-00
Removal and installation of operator's cab and floor frame assembly	2
Removal and installation of operator's cab glass (Stuck glass)	7
Removal and installation of air conditioner unit	15
800 Electrical system	SEN05328-00
Removal and installation of monitor panel	2
Removal and installation of engine controller assembly	4
Removal and installation of HST controller assembly	6
Removal and installation of KOMTRAX terminal assembly	7

90 Diagrams and drawings	
100 Hydraulic diagrams and drawings	SEN05329-00
Hydraulic circuit diagram	3
200 Electrical diagrams and drawings	SEN05330-00
Common electrical circuit diagram	3
Specific electrical circuit diagram	21
Connector list and stereogram	23

WHEEL LOADER

WA200-6

WA200PZ-6

Machine model	Serial number
WA200-6	70001 and up
WA200PZ-6	70001 and up

00 Index and foreword

200 Foreword and general information

Safety notice	2
How to read the shop manual	7
Explanation of terms for maintenance standard	9
Handling of electric equipment and hydraulic component	11
Handling of connectors newly used for engines	20
How to read electric wire code	23
Precautions when carrying out operation.....	26
Method of disassembling and connecting push-pull type coupler.....	29
Standard tightening torque table	32
Conversion table	36

Safety notice

(Rev. 2008/08)

Important safety notice

Proper service and repair are extremely important for safe machine operation. The service and repair techniques recommended by Komatsu and described in this manual are both effective and safe. Some of these techniques require the use of tools specially designed by Komatsu for the specific purpose.

To prevent injury to workers, the symbol **▲** is used to mark safety precautions in this manual. The cautions accompanying these symbols should always be followed carefully. If any dangerous situation arises or may possibly arise, first consider safety, and take the necessary actions to deal with the situation.

1. General precautions

▲ Mistakes in operation are extremely dangerous. Read the Operation and Maintenance Manual carefully before operating the machine. In addition, read this manual and understand its contents before starting the work.

- 1) Before carrying out any greasing or repairs, read all the safety labels stuck to the machine. For the locations of the safety labels and detailed explanation of precautions, see the Operation and Maintenance Manual.
- 2) Decide a place in the repair workshop to keep tools and removed parts. Always keep the tools and parts in their correct places. Always keep the work area clean and make sure that there is no dirt, water, or oil on the floor. Smoke only in the areas provided for smoking. Never smoke while working.
- 3) When carrying out any operation, always wear safety shoes and helmet. Do not wear loose work clothes, or clothes with buttons missing.
 - Always wear safety glasses when hitting parts with a hammer.
 - Always wear safety glasses when grinding parts with a grinder, etc.
- 4) When carrying out any operation with 2 or more workers, always agree on the operating procedure before starting. Always inform your fellow workers before starting any step of the operation. Before starting work, hang UNDER REPAIR warning signs in the operator's compartment.
- 5) Only qualified workers must carry out work and operation which require license or qualification.
- 6) Keep all tools in good condition, learn the correct way to use them, and use the proper ones of them. Before starting work, thoroughly check the tools, machine, fork-lift, service car, etc.

- 7) If welding repairs are needed, always have a trained and experienced welder carry out the work. When carrying out welding work, always wear welding gloves, apron, shielding goggles, cap and other clothes suited for welding work.
- 8) Before starting work, warm up your body thoroughly to start work under good condition.
- 9) Avoid continuing work for long hours and take rests at proper intervals to keep your body in good condition. Take rests in specified safe places.

Safety points

1	Good arrangement
2	Correct work clothes
3	Following work standard
4	Making and checking signs
5	Prohibition of operation and handling by unlicensed workers
6	Safety check before starting work
7	Wearing protective goggles (for cleaning or grinding work)
8	Wearing shielding goggles and protectors (for welding work)
9	Good physical condition and preparation
10	Precautions against work which you are not used to or you are used to too much

2. Preparations for work

- 1) Before adding oil or making any repairs, park the machine on a hard and level ground, and apply the parking brake and block the wheels or tracks to prevent the machine from moving.
- 2) Before starting work, lower the work equipment (blade, ripper, bucket, etc.) to the ground. If this is not possible, insert the lock pin or use blocks to prevent the work equipment from falling. In addition, be sure to lock all the control levers and hang warning signs on them.
- 3) When disassembling or assembling, support the machine with blocks, jacks, or stands before starting work.
- 4) Remove all mud and oil from the steps or other places used to get on and off the machine. Always use the handrails, ladders or steps when getting on or off the machine. Never jump on or off the machine. If it is impossible to use the handrails, ladders or steps, use a stand to provide safe footing.

3. Precautions during work

- 1) Before disconnecting or removing components of the oil, water, or air circuits, first release the pressure completely from the circuit. When removing the oil filler cap, a drain plug, or an oil pressure pickup plug, loosen it slowly to prevent the oil from spurting out.
- 2) The coolant and oil in the circuits are hot when the engine is stopped, so be careful not to get scalded. Wait for the oil and coolant to cool before carrying out any work on the oil or water circuits.
- 3) Before starting work, stop the engine. When working on or around a rotating part, in particular, stop the engine. When checking the machine without stopping the engine (measuring oil pressure, revolving speed, temperature, etc.), take extreme care not to get rolled or caught in rotating parts or moving parts.
- 4) Before starting work, remove the leads from the battery. Always remove the lead from the negative (-) terminal first.
- 5) When raising a heavy component (heavier than 25 kg), use a hoist or crane. Before starting work, check that the slings (wire ropes, chains, and hooks) are free from damage. Always use slings which have ample capacity and install them to proper places. Operate the hoist or crane slowly to prevent the component from hitting any other part. Do not work with any part still raised by the hoist or crane.
- 6) When removing a cover which is under internal pressure or under pressure from a spring, always leave 2 bolts in diagonal positions. Loosen those bolts gradually and alternately to release the pressure, and then remove the cover.
- 7) When removing components, be careful not to break or damage the electrical wiring. Damaged wiring may cause electrical fires.
- 8) When removing piping, stop the fuel or oil from spilling out. If any fuel or oil drips onto the floor, wipe it up immediately. Fuel or oil on the floor can cause you to slip and can even start fires.
- 9) As a general rule, do not use gasoline to wash parts. Do not use it to clean electrical parts, in particular.
- 10) Be sure to assemble all parts again in their original places. Replace any damaged parts and parts which must not be reused with new parts. When installing hoses and wires, be sure that they will not be damaged by contact with other parts when the machine is operated.
- 11) When installing high pressure hoses, make sure that they are not twisted. Damaged tubes are dangerous, so be extremely careful when installing tubes for high pressure circuits. In addition, check that connecting parts are correctly installed.
- 12) When assembling or installing parts, always tighten them to the specified torques. When installing protective parts such as guards, or parts which vibrate violently or rotate at high speed, be particularly careful to check that they are installed correctly.
- 13) When aligning 2 holes, never insert your fingers or hand. Be careful not to get your fingers caught in a hole.
- 14) When measuring hydraulic pressure, check that the measuring tools are correctly assembled.
- 15) Take care when removing or installing the tracks of track-type machines. When removing the track, the track separates suddenly, so never let anyone stand at either end of the track.
- 16) If the engine is operated for a long time in a place which is not ventilated well, you may suffer from gas poisoning. Accordingly, open the windows and doors to ventilate well.

4. Precautions for sling work and making signs

- 1) Only one appointed worker must make signs and co-workers must communicate with each other frequently. The appointed sign maker must make specified signs clearly at a place where he is well seen from the operator's seat and where he can see the working condition easily. The sign maker must always stand in front of the load and guide the operator safely.
 - Do not stand under the load.
 - Do not step on the load.
- 2) Check the slings before starting sling work.
- 3) Keep putting on gloves during sling work. (Put on leather gloves, if available.)
- 4) Measure the weight of the load by the eye and check its center of gravity.
- 5) Use proper sling according to the weight of the load and method of slinging. If too thick wire ropes are used to sling a light load, the load may slip and fall.
- 6) Do not sling a load with 1 wire rope alone. If it is slung so, it may rotate and may slip out of the rope. Install 2 or more wire ropes symmetrically.

⚠ Slinging with 1 rope may cause turning of the load during hoisting, untwisting of the rope, or slipping of the rope from its original winding position on the load, which can result in a dangerous accident.

- 7) Limit the hanging angle to 60°, as a rule. Do not sling a heavy load with ropes forming a wide hanging angle from the hook. When hoisting a load with 2 or more ropes, the force subjected to each rope will increase with the hanging angle. The table below shows the variation of allowable load in kN {kg} when hoisting is made with 2 ropes, each of which is allowed to sling up to 9.8 kN {1,000 kg} vertically, at various hanging angles. When the 2 ropes sling a load vertically, up to 19.6 kN {2,000 kg} of total weight can be suspended. This weight is reduced to 9.8 kN {1,000 kg} when the 2 ropes make a hanging angle of 120°. If the 2 ropes sling a 19.6 kN {2,000 kg} load at a lifting angle of 150°, each of them is subjected to a force as large as 39.2 kN {4,000 kg}.

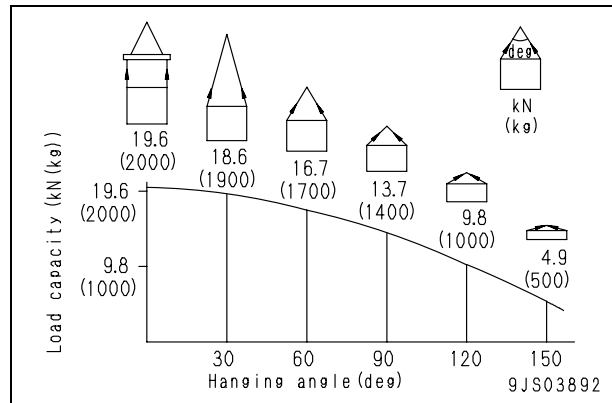

- 8) When installing wire ropes to an angular load, apply pads to protect the wire ropes. If the load is slippery, apply proper material to prevent the wire rope from slipping.
- 9) Use the specified eyebolts and fix wire ropes, chains, etc. to them with shackles, etc.
- 10) Apply wire ropes to the middle portion of the hook.
 - Slinging near the tip of the hook may cause the rope to slip off the hook during hoisting. The hook has the maximum strength at the middle portion.

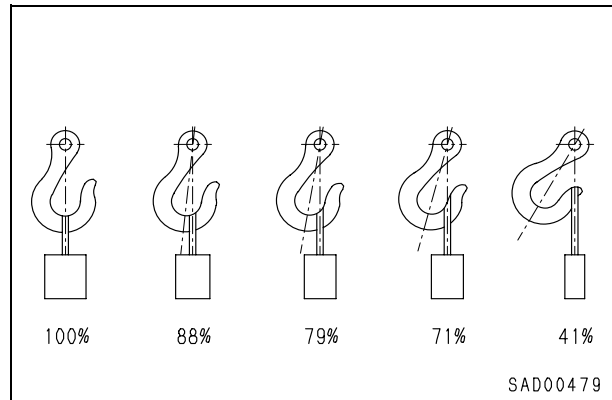

- 11) Do not use twisted or kinked wire ropes.
- 12) When lifting up a load, observe the following.
 - Wind in the crane slowly until wire ropes are stretched. When settling the wire ropes with the hand, do not grasp them but press them from above. If you grasp them, your fingers may be caught.
 - After the wire ropes are stretched, stop the crane and check the condition of the slung load, wire ropes, and pads.

- If the load is unstable or the wire rope or chains are twisted, lower the load and lift it up again.
 - Do not lift up the load slantingly.
- 13) When lifting down a load, observe the following.
- When lifting down a load, stop it temporarily at 30 cm above the floor, and then lower it slowly.
 - Check that the load is stable, and then remove the sling.
 - Remove kinks and dirt from the wire ropes and chains used for the sling work, and put them in the specified place.

5. Precautions for using mobile crane

- ★ Read the Operation and Maintenance Manual of the crane carefully in advance and operate the crane safely.

6. Precautions for using overhead hoist crane

▲ When raising a heavy part (heavier than 25 kg), use a hoist, etc. In Disassembly and assembly, the weight of a part heavier than 25 kg is indicated after the mark of .

- 1) Before starting work, inspect the wire ropes, brake, clutch, controller, rails, over wind stop device, electric shock prevention earth leakage breaker, crane collision prevention device, and power application warning lamp, and check safety.
- 2) Observe the signs for sling work.
- 3) Operate the hoist at a safe place.
- 4) Check the direction indicator plates (east, west, south, and north) and the directions of the control buttons without fail.
- 5) Do not sling a load slantingly. Do not move the crane while the slung load is swinging.
- 6) Do not raise or lower a load while the crane is moving longitudinally or laterally.
- 7) Do not drag a sling.
- 8) When lifting up a load, stop it just after it leaves the ground and check safety, and then lift it up.
- 9) Consider the travel route in advance and lift up a load to a safe height.
- 10) Place the control switch on a position where it will not be an obstacle to work and passage.
- 11) After operating the hoist, do not swing the control switch.
- 12) Remember the position of the main switch so that you can turn off the power immediately in an emergency.

- 13) If the hoist stops because of a power failure, turn the power switch OFF. When turning on a switch which was turned OFF by the electric shock prevention earth leakage breaker, check that the devices related to that switch are not in operation state.
- 14) If you find an obstacle around the hoist, stop the operation.
- 15) After finishing the work, stop the hoist at the specified position and raise the hook to at least 2 m above the floor. Do not leave the sling installed to the hook.

7. Selecting wire ropes

- 1) Select adequate ropes depending on the weight of parts to be hoisted, referring to the table below.

Wire ropes
(Standard "Z" twist ropes without galvanizing)
(JIS G3525, No. 6, Type 6X37-A)

Nominal diameter of rope mm	Allowable load	
	kN	ton
10	8.8	0.9
12	12.7	1.3
14	17.3	1.7
16	22.6	2.3
18	28.6	2.9
20	35.3	3.6
25	55.3	5.6
30	79.6	8.1
40	141.6	14.4
50	221.6	22.6
60	318.3	32.4

- ★ The allowable load is one-sixth of the breaking strength of the rope used (Safety coefficient: 6).

8. Precautions for disconnecting and connecting hoses and tubes in air conditioner circuit

1) Disconnection

⚠ For the environment, the air conditioner of this machine uses the refrigerant (air conditioner gas: R134a) which has fewer factors of the depletion of the ozone layer. However, it does not mean that you may discharge the refrigerant into the atmosphere as it is. Be sure to recover the refrigerant when disconnecting the refrigerant gas circuit and then reuse it.

★ Ask professional traders for collecting and filling operation of refrigerant (R134a).

★ Never release the refrigerant (R134a) to the atmosphere.

⚠ If the refrigerant gas gets in your eyes or contacts your skin, you may lose your sight and your skin may be frozen. Accordingly, put on safety glasses, safety gloves and safety clothes when recovering or adding the refrigerant. Refrigerant gas must be recovered and added by a qualified person.

2) Connection

1] When installing the air conditioner circuit hoses and tubes, take care that dirt, dust, water, etc. will not enter them.

2] When connecting the air conditioner hoses and tubes, check that O-rings (1) are fitted to their joints.

3] Check that each O-ring is not damaged or deteriorated.

4] When connecting the refrigerant piping, apply compressor oil for refrigerant (R134a) (**DENSO: ND-OIL8, VALEO THERMAL SYSTEMS: ZXL100PG (equivalent to PAG46)**) to its O-rings.

★ Example of O-ring (Fitted to every joint of hoses and tubes)

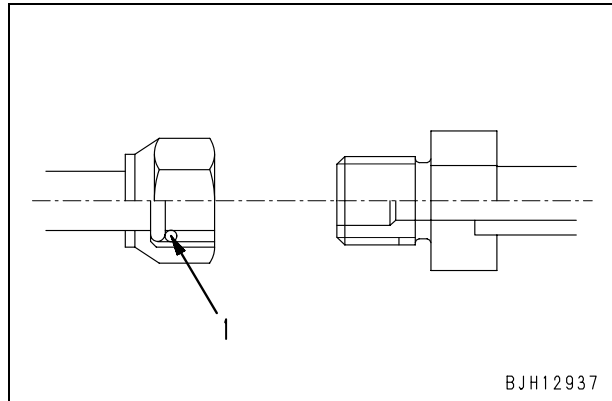

★ For tightening torque, see the precautions for installation in each section of "Disassembly and assembly".

WHEEL LOADER

WA200-6

WA200PZ-6

Machine model	Serial number
WA200-6	70001 and up
WA200PZ-6	70001 and up

50 Disassembly and assembly

301 Power train, Part 1

Disassembly and assembly of transfer assembly	2
Removal and installation of parking brake assembly	21
Disassembly and assembly of parking brake assembly	23

Disassembly and assembly of transfer assembly

Special tools

Symbol	Part No.	Part name	Necessity	Q'ty	New/Remodel	Sketch	
D	1	790-201-2840	Spacer	■	1		
	2	793T-417-1110	Push tool	■	1	○	
	3	790-101-5201	Push tool kit	■	1		
		790-101-5311	• Plate		1		
		790-101-5221	• Grip		1		
		01010-51225	• Bolt		1		
	4	793T-417-1120	Push tool	■	1	○	
		790-101-5221	Grip	■	1		
		01010-81225	Bolt	■	1		
	5	799-301-1500	Oil leak tester	■	1		
	8	790-201-3260	Bolt (12 x 1.75 mm)	●	2		
	9	790-102-2900	Puller	●	1		
	10	792-735-2420	Collar	■	1		
	11	790-101-2501	Puller	●	1		
	12	790-201-1320	Spacer	■	1		
	13	790-101-3101	Bearing puller	●	1		
	14	793T-417-1130	Push tool	■	1	○	
	15	790-101-3501	Gear puller	●	1		
	16	790-101-3401	Bearing puller	●	1		
	17	79G-17L-1000	Bar	■	1		
	18	795-100-1291	Sleeve driver	■	1		
	19	796-430-1110	Push tool	■	1		
	20	790-470-1410	Collar	■	1		
	21	796-667-1310	Collar	■	1		
22	791-126-0130	Push tool	■	1			
23	Commercially available	Torque wrench	●	1			
24	790-434-1470	Push tool	■	1			

Disassembly

1. Draining transfer oil

 Transfer case: **Approx. 6.5 ℓ**

2. Related sensors

Remove speed sensor (75).

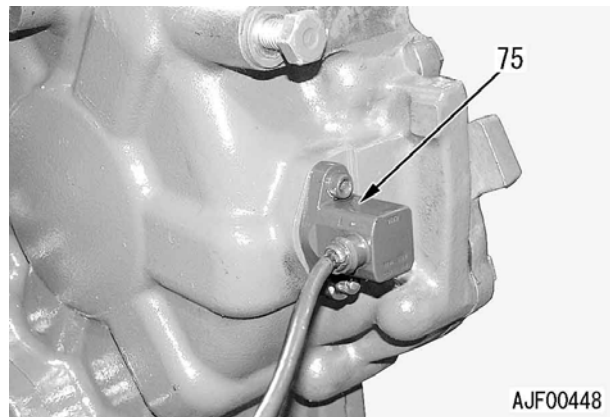

AJF00448

3. Brake accumulator

- 1) Disconnect wiring harness connectors CN-T06 (1), CN-T07 (2), CN-T10 (3) and CN-T11 (4).

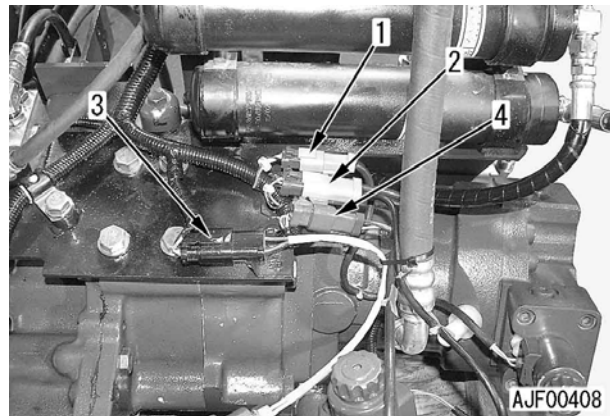

AJF00408

- 2) Disconnect clutch port hose (5) and hose clamp.
- 3) Remove the 6 mounting bolts and remove brake accumulator and transfer oil filter bracket assembly (6).

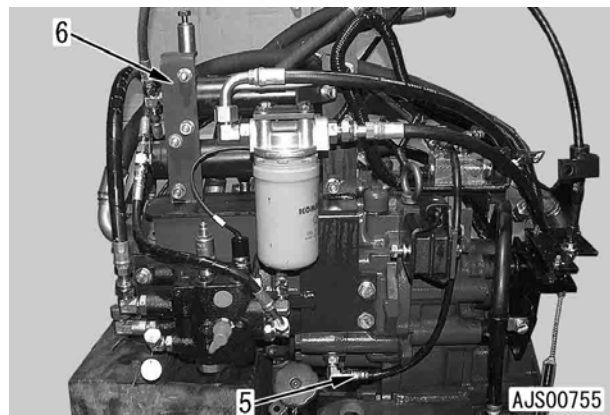

AJS00755

4. HST motor

- 1) Remove hoses (7) – (10) from HST motors 1 and 2.

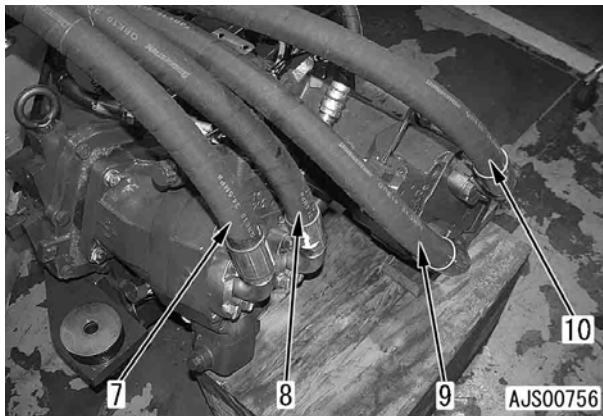

- 2) Remove 4 mounting bolts each and lift off HST motor 1 (11) and HST motor 2 (12).

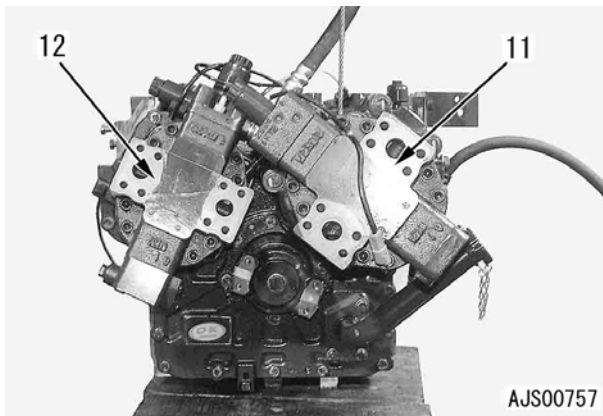

5. Oil supply pipe

Remove oil supply pipe (13).

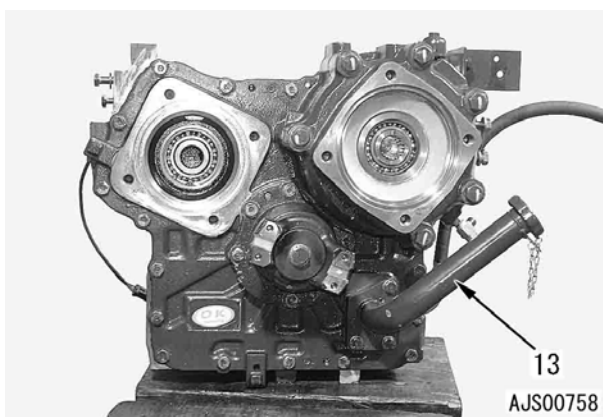

6. Parking brake control cable

- 1) Disconnect hose (13a).
- 2) Remove parking brake control cable (13b) and bracket (13c) together.

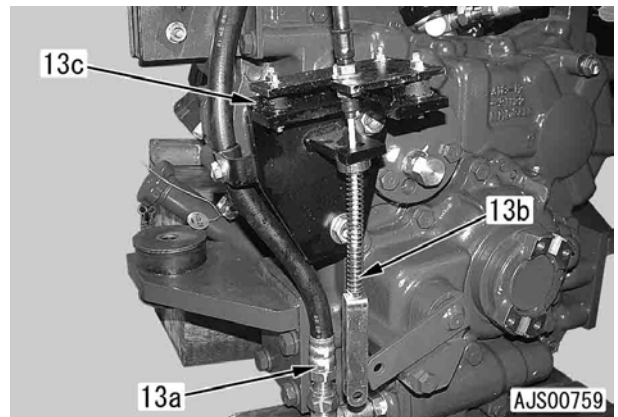

7. Parking brake assembly

- 1) Remove breather tube (14).
- 2) Set the transfer assembly to a block with the parking brake side up.
- 3) Remove coupling (14a) on the parking brake side.

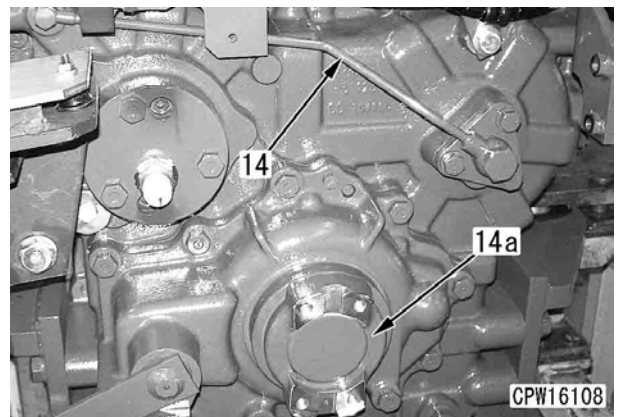

- 4) Remove the mounting bolts. Using tool **D8**, remove parking brake assembly (15).
★ For disassembly and assembly of the parking brake assembly, see "Disassembly and assembly of parking brake assembly".

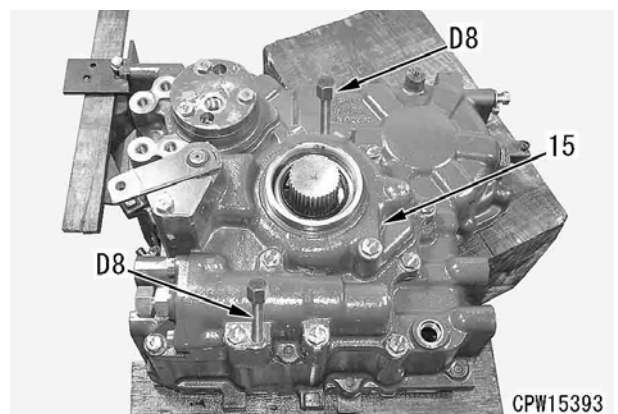

8. Hub

- 1) Remove snap ring (16).
- 2) Remove hub (17).

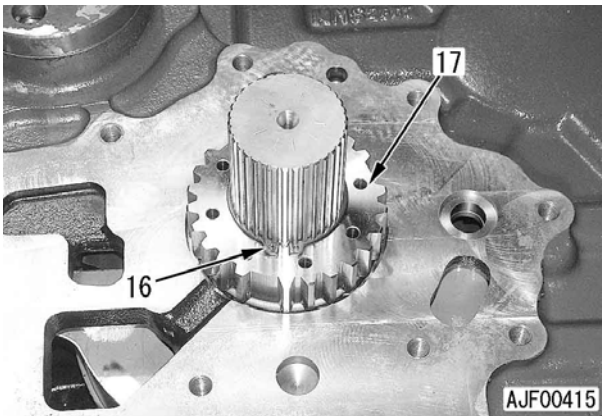

9. Belleville springs

- 1) Turn over the case and remove cage (18) from the HST motor mounting section.
 - ★ Loosen the mounting bolts evenly and gradually release the belleville springs, and then remove the cage.
 - Free height of belleville springs (4-piece set): 32.8 mm
 - Installed height of belleville springs (4-piece set): 25.6 mm
 - Installed load of belleville springs (4-piece set): 21,500 N {2,190 kg}

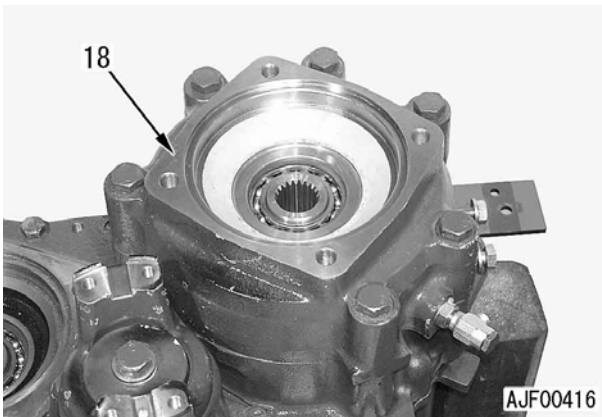

- 2) Remove 4 belleville springs (19).
 - ★ Check the directions of the belleville springs.
 - ★ The 1st and 4th belleville springs have white marks.
 - ★ When any belleville spring needs to be replaced, replace all of the 4 springs as a set.

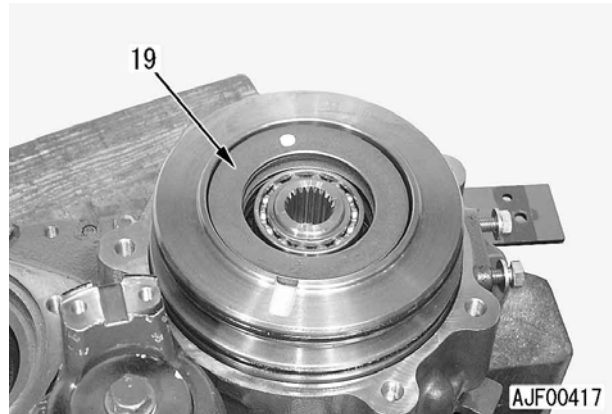

10. Piston and spacer

- 1) Remove piston (20).

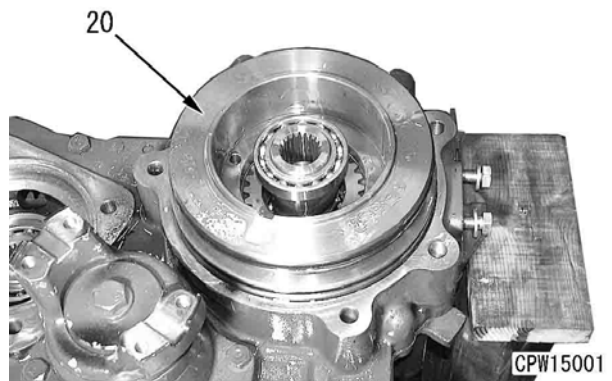

- 2) Put copper plate [1] in the O-ring groove and remove spacer (21) with flat-head screwdriver [2].

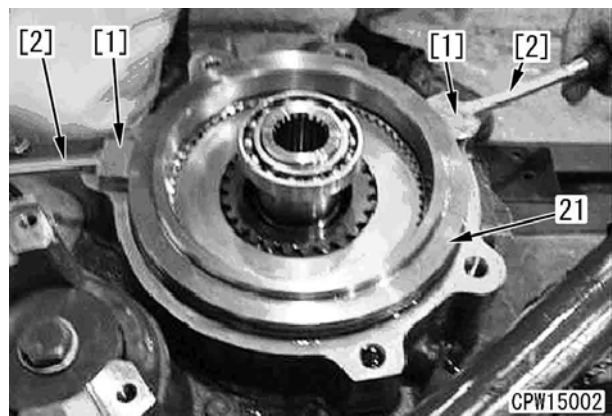



Download the full PDF manual instantly.

Our customer service e-mail:

aservicemanualpdf@yahoo.com