

Shop Manual

WA180-3 WA180L-3 WHEEL LOADER

SERIAL NUMBERS WA180-3L - A80001 and up
WA180L-3 - 54001

This material is proprietary to Komatsu America International Company and is not to be reproduced, used, or disclosed except in accordance with written authorization from Komatsu America International Company.

It is our policy to improve our products whenever it is possible and practical to do so. We reserve the right to make changes or add improvements at any time without incurring any obligation to install such changes on products sold previously.

Due to this continuous program of research and development, periodic revisions may be made to this publication. It is recommended that customers contact their distributor for information on the latest revision.

CONTENTS



| | | |
|----|--------------------------------|------|
| 01 | GENERAL | 01-1 |
| 10 | STRUCTURE AND FUNCTION | 10-1 |
| 20 | TESTING AND ADJUSTMENT | 20-1 |
| 30 | DISASSEMBLY AND ASSEMBLY | 30-1 |
| 40 | MAINTENANCE STANDARD | 40-1 |

SAFETY

SAFETY NOTICE

IMPORTANT SAFETY NOTICE

Proper service and repair is extremely important for the safe operation of your machine. The service and repair techniques recommended and described in this manual are both effective and safe methods of operation. Some of these operations require the use of tools specially designed for the purpose.

To prevent injury to workers, the symbols  and  are used to mark safety precautions in this manual. The cautions accompanying these symbols should always be followed carefully. If any dangerous situation arises or may possibly arise, first consider safety, and take the necessary actions to deal with the situation.

GENERAL PRECAUTIONS

Mistakes in operation are extremely dangerous. Read the OPERATION & MAINTENANCE MANUAL carefully BEFORE operating the machine.

1. Before carrying out any greasing or repairs, read all the precautions given on the decals which are fixed to the machine.
2. When carrying out any operation, always wear safety shoes and helmet. Do not wear loose work clothes, or clothes with buttons missing.
 - Always wear safety glasses when hitting parts with a hammer.
 - Always wear safety glasses when grinding parts with a grinder, etc.
3. If welding repairs are needed, always have a trained, experienced welder carry out the work. When carrying out welding work, always wear welding gloves, apron, glasses, cap and other clothes suited for welding work.
4. When carrying out any operation with two or more workers, always agree on the operating procedure before starting. Always inform your fellow workers before starting any step of the operation. Before starting work, hang UNDER REPAIR signs on the controls in the operator's compartment.
5. Keep all tools in good condition and learn the correct way to use them.
6. Decide a place in the repair workshop to keep tools and removed parts. Always keep the tools and parts in their correct places. Always keep the work area

clean and make sure that there is no dirt or oil on the floor. Smoke only in the areas provided for smoking. Never smoke while working.

PREPARATIONS FOR WORK

7. Before adding oil or making repairs, park the machine on hard, level ground, and block the wheels or tracks to prevent the machine from moving.
8. Before starting work, lower blade, ripper, bucket or any other work equipment to the ground. If this is not possible, insert the safety pin or use blocks to prevent the work equipment from falling. In addition, be sure to lock all the control levers and hang warning signs on them.
9. When disassembling or assembling, support the machine with blocks, jacks or stands before starting work.
10. Remove all mud and oil from the steps or other places used to get on and off the machine. Always use the handrails, ladders or steps when getting on or off the machine. Never jump on or off the machine. If it is impossible to use the handrails, ladders or steps, use a stand to provide safe footing.

PRECAUTIONS DURING WORK

11. When removing the oil filler cap, drain plug or hydraulic pressure measuring plugs, loosen them slowly to prevent the oil from spurting out. Before disconnecting or removing components of the oil,

- water or air circuits, first remove the pressure completely from the circuit.
12. The water and oil in the circuits are hot when the engine is stopped, so be careful not to get burned. Wait for the oil and water to cool before carrying out any work on the oil or water circuits.
 13. Before starting work, remove the leads from the battery. ALWAYS remove the lead from the negative (-) terminal first.
 14. When raising heavy components, use a hoist or crane. Check that the wire rope, chains and hooks are free from damage. Always use lifting equipment which has ample capacity. Install the lifting equipment at the correct places. Use a hoist or crane and operate slowly to prevent the component from hitting any other part. Do not work with any part still raised by the hoist or crane.
 15. When removing covers which are under internal pressure or under pressure from a spring, always leave two bolts in position on opposite sides. Slowly release the pressure, then slowly loosen the bolts to remove.
 16. When removing components, be careful not to break or damage the wiring, Damaged wiring may cause electrical fires.
 17. When removing piping, stop the fuel or oil from spilling out. If any fuel or oil drips on to the floor, wipe it up immediately. Fuel or oil on the floor can cause you to slip, or can even start fires.
 18. As a general rule, do not use gasoline to wash parts. In particular, use only the minimum of gasoline when washing electrical parts.
 19. Be sure to assemble all parts again in their original places. Replace any damaged part with new parts.
 - When installing hoses and wires, be sure that they will not be damaged by contact with other parts when the machine is being operated.
 20. When installing high pressure hoses, make sure that they are not twisted. Damaged tubes are dangerous, so be extremely careful when installing tubes for high pressure circuits. Also check that connecting parts are correctly installed.
 21. When assembling or installing parts, always use the specified tightening torques. When installing protective parts such as guards, or parts which vibrate violently or rotate at high speed, be particularly careful to check that they are installed correctly.
 22. When aligning two holes, never insert your fingers or hand. Be careful not to get your fingers caught in a hole.
 23. When measuring hydraulic pressure, check that the measuring tool is correctly assembled before taking any measurements.
 24. Take care when removing or installing the tracks of track-type machines. When removing the track, the track separates suddenly, so never let anyone stand at either end of the track.

FOREWARD

GENERAL

This shop manual has been prepared as an aid to improve the quality of repairs by giving the serviceman an accurate understanding of the product and by showing him the correct way to perform repairs and make judgements. Make sure you understand the contents of this manual and use it to full effect at every opportunity.

This shop manual mainly contains the necessary technical information for operations performed in a service workshop. For ease of understanding, the manual is divided into the following sections. These sections are further divided into each main group of components.

GENERAL

This section lists the general machine dimensions, performance specifications, component weights, and fuel, coolant and lubricant specification charts.

STRUCTURE AND FUNCTION

This section explains the structure and function of each component. It serves not only to give an understanding of the structure, but also serves as reference material for troubleshooting.

TESTING AND ADJUSTING

This section explains checks to be made before and after performing repairs, as well as adjustments to be made at completion of the checks and repairs. Troubleshooting charts correlating "Problems" to "Causes" are also included in this section.

DISASSEMBLY AND ASSEMBLY

This section explains the order to be followed when removing, installing, disassembling or assembling each component, as well as precautions to be taken for these operations.

MAINTENANCE STANDARD

This section gives the judgement standards when inspecting disassembled parts.

NOTICE

The specifications contained in this shop manual are subject to change at any time and without any advance notice. Contact your distributor for the latest information.

HOW TO READ THE SHOP MANUAL

VOLUMES

Shop manuals are issued as a guide to carrying out repairs. They are divided as follows:

- Chassis volume:** Issued for every machine model
- Engine volume:** Issued for each engine series
- Electrical volume:** Each issued as one to cover all models
- Attachment volume:** Each issued as one to cover all models

These various volumes are designed to avoid duplication of information. Therefore to deal with all repairs for any model, it is necessary that chassis, engine electrical and attachment be available.

DISTRIBUTION AND UPDATING

Any additions, amendments or other changes will be sent to your distributors. Get the most up-to-date information before you start any work.

FILING METHOD

1. See the page number on the bottom of the page. File the pages in correct order.
2. Following examples show how to read the page number:

Example 1 (Chassis volume):

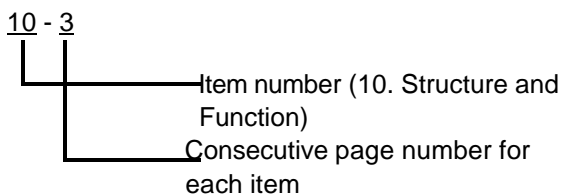

Example 2 (Engine volume):
Refer to the pertinent engine manual.

3. Additional pages: Additional pages are indicated by a hyphen (-) and numbered after the page number. File as in the example.

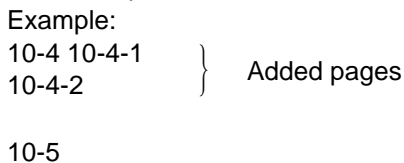

REVISED EDITION MARK

When a manual is revised, an edition mark (①②③ ...) is recorded on the bottom outside corner of the pages.

REVISIONS

Revised pages are shown at the LIST OF REVISED PAGES between the title page and SAFETY page.

SYMBOLS

So that the shop manual can be of ample practical use, important places for safety and quality are marked with the following symbols.

| Symbol | Item | Remarks |
|--------|-------------------|---|
| | Safety | Special safety precautions are necessary when performing the work. |
| | Caution | Special technical precautions or other precautions for preserving standards are necessary when performing the work. |
| | Weight | Weight of parts or systems. Caution necessary when selecting hoisting wire or when working posture is important, etc. |
| | Tightening torque | Places that require special attention for tightening torque during assembly. |
| | Coat | Places to be coated with adhesives and lubricants etc. |
| | Oil, water | Places where oil, water or fuel must be added, and the capacity. |
| | Drain | Places where oil or water must be drained, and quantity to be drained. |

HOISTING INSTRUCTIONS

HOISTING

 Heavy parts (25 kg or more) must be lifted with a hoist etc. In the **DISASSEMBLY AND ASSEMBLY** section, every part weighing 25 kg or more is indicated clearly with the symbol



- If a part cannot be smoothly removed from the machine by hoisting, the following checks should be made:
 - 1) Check for removal of all bolts fastening the part to the relative parts.
 - 2) Check for existence of another part causing interface with the part to be removed.

WIRE ROPES

- 1) Use adequate ropes depending on the weight of parts to be hoisted, referring to the table below:

| Wire ropes (Standard "Z" or "S" twist ropes without galvanizing) | |
|---|-----------------------|
| Rope diameter (mm) | Allowable load (tons) |
| 10.0 | 1.0 |
| 11.2 | 1.4 |
| 12.5 | 1.6 |
| 14.0 | 2.2 |
| 16.0 | 2.8 |
| 18.0 | 3.6 |
| 20.0 | 4.4 |
| 22.4 | 5.6 |
| 30.0 | 10.0 |
| 40.0 | 18.0 |
| 50.0 | 28.0 |
| 60.0 | 40.0 |

★ The allowable load value is estimated to be 1/6 or 1/7 of the breaking strength of the rope used.

- 2) Sling wire ropes from the middle portion of the hook. Slings near the edge of the hook may cause the rope to slip off the hook during hoisting, and a serious accident can result. Hooks have maximum strength at the middle portion.

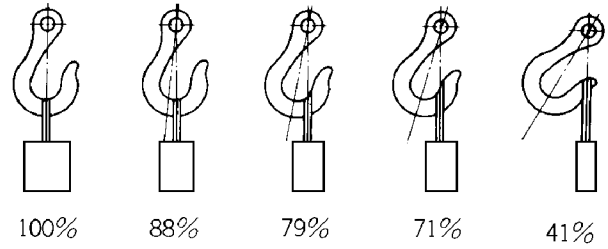

FS0064

- 3) Do not sling a heavy load with one rope alone, but sling with two or more ropes symmetrically wound on to the load.

 Slings with one rope may cause turning of the load during hoisting, untwisting of the rope, or slipping of the rope from its original winding position on the load, which can result in a dangerous accident.

- 4) Do not sling a heavy load with ropes forming a wide hanging angle from the hook. When hoisting a load with two or more ropes, the force subjected to each rope will increase with the hanging angles. The table below shows the variation of allowable load (kg) when hoisting is made with two ropes, each of which is allowed to sling up to 1000 kg vertically, at various hanging angles. When two ropes sling a load vertically, up to 2000 kg of total weight can be suspended. This weight becomes 1000 kg when two ropes make a 120° hanging angle. On the other hand, two ropes are subject to an excessive force as large as 4000 kg if they sling a 2000 kg load at a lifting angle of 150°.

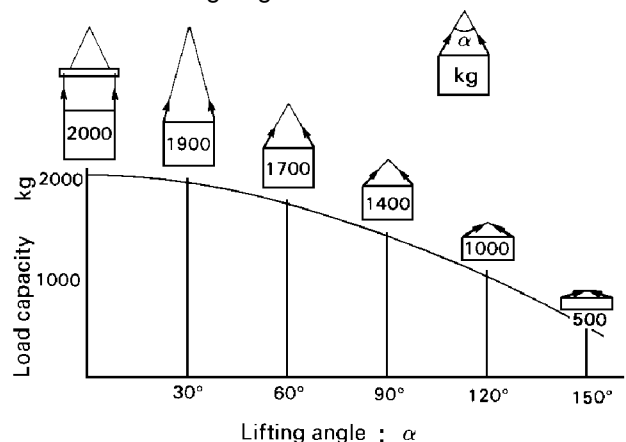

FS0065

STARTING MOTOR



WARNING! Stop the machine on level ground and install the safety bar on the frame. Lower the bucket to the ground and stop the engine. Then apply the parking brake and put blocks under the wheels to prevent the machine from moving.



WARNING! Disconnect the cable from the negative (-) terminal of the battery.

REMOVAL

1. Disconnect negative (-) terminal (1) of the battery located behind the radiator grille.
2. Open engine hood side cover and lock in position.
3. Remove washer tank and bracket (2) and two mounting bolts with nuts (3) from frame and position out of way.
4. Disconnect cable (4) and harness wires (5) and (6).
5. Remove ground connection (7) with two mounting bolts (8), then remove starting motor assembly.

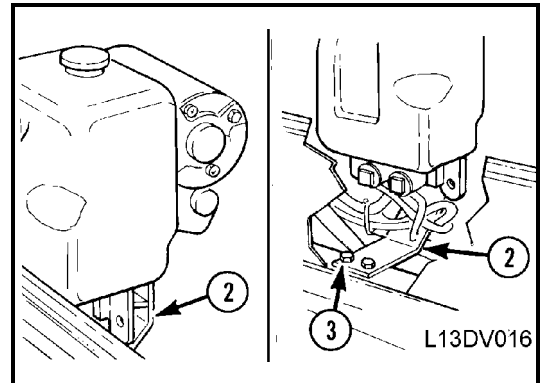
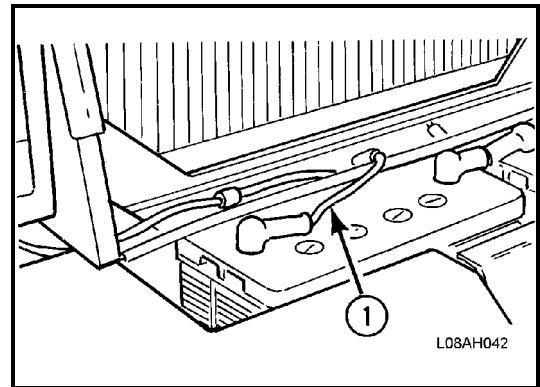

INSTALLATION

Install starting motor assembly in reverse order of removal



Mounting bolt: 32 ± 4 lbf.ft
 $(43 \pm 6$ Nm)
 $(4.38 \pm 0.61$ kgm)

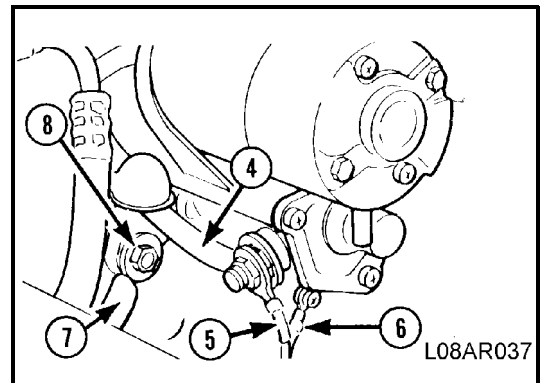

ALTERNATOR



WARNING! Stop the machine on level ground and install the safety bar on the frame. Lower the bucket to the ground and stop the engine. Then apply the parking brake and put blocks under the wheels to prevent the machine from moving.



WARNING! Disconnect the cable from the negative (-) terminal of the battery.

REMOVAL

1. Disconnect negative (-) terminal (1) of the battery located behind the radiator grille.
2. Open engine hood side cover and lock in position.
3. Remove 5 mounting bolts of left fan guard half (2) and rotate down out of way.
4. Install 3/8" drive breaker bar (3) in belt tensioner. Lift up on breaker bar and remove belt (4) from alternator pulley.
5. Remove output (5) and ground (6) leads from back of alternator.
6. Remove bottom mounting bolt (7). Supporting the alternator, remove top mounting bolt (8) and remove the alternator from the machine.

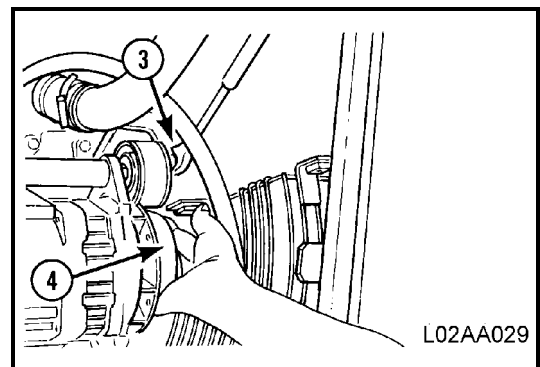
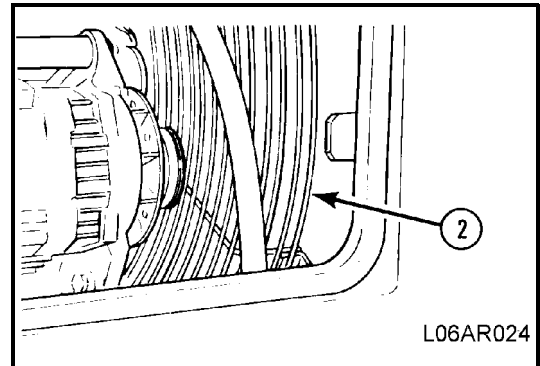
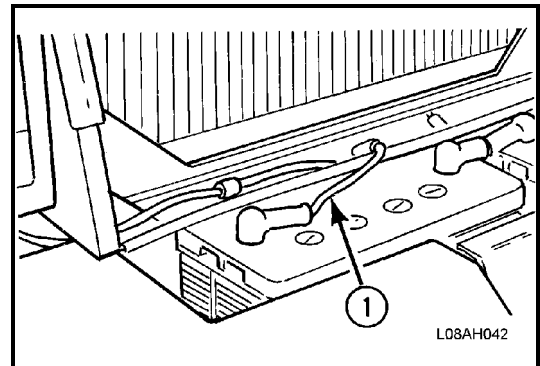

INSTALLATION

Install starting motor assembly in reverse order of removal



Mounting bolt: 32 ±4 lbf.ft
(43 ±6 Nm)
(4.38 ±0.61 kgm)

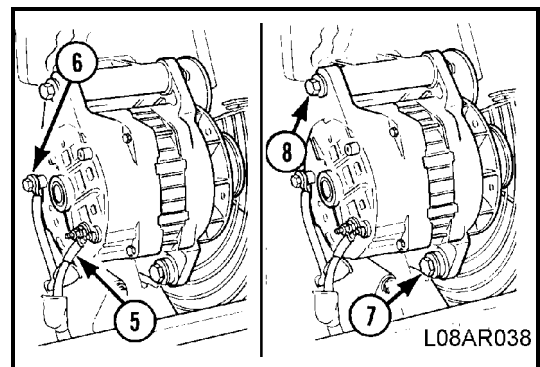

FUEL INJECTION PUMP



WARNING! Stop the machine on level ground and install the safety bar on the frame. Lower the bucket to the ground and stop the engine. Then apply the parking brake and put blocks under the wheels to prevent the machine from moving.

REMOVAL

1. Disconnect negative (-) terminal (1) of the battery located behind the radiator grille.
2. Open engine hood right side cover and lock in position (3).
3. Disconnect the throttle linkage (4).
4. Disconnect the fuel inlet line (filter to pump line) (5).
5. Disconnect the return (6) and drain lines (7).
6. Disconnect the electrical wiring (8).
7. Disconnect the six fuel lines (pump to injectors) (9).
8. Remove the Fuel Injection Pump.
Refer to "ENGINE SHOP MANUAL".

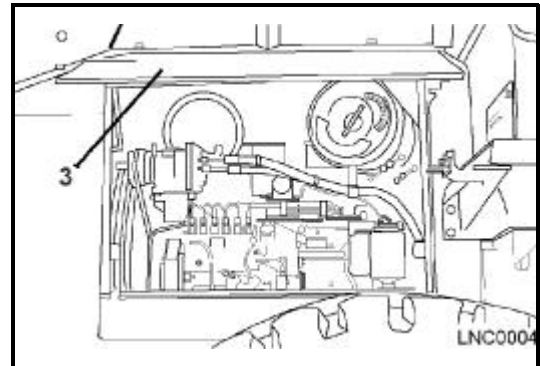
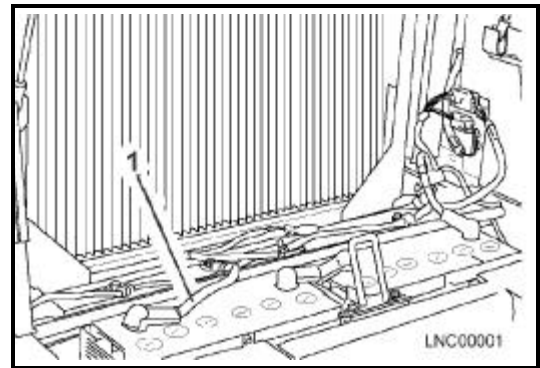

INSTALLATION

Install fuel injection pump assembly in reverse order of removal

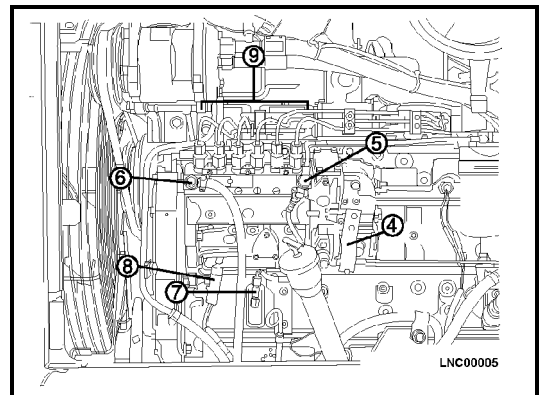

ENGINE OIL COOLER



WARNING! Stop the machine on level ground and install the safety bar on the frame. Lower the bucket to the ground and stop the engine. Then apply the parking brake and put blocks under the wheels to prevent the machine from moving.



WARNING! Disconnect the cable from the negative (-) terminal of the battery.

REMOVAL

1. Disconnect negative (-) terminal (1) of the battery located behind the radiator grille.
2. Open left gull wing side cover (2) on the engine hood and lock in position.
3. Drain the engine oil.
Refer to "OPERATIONAL & MAINTENANCE MANUAL".
4. Remove the alternator.
Refer to "ENGINE SHOP MANUAL".
5. Remove the turbocharger drain line (3).
6. Remove the Oil Filter.
Refer to "OPERATIONAL & MAINTENANCE MANUAL".
7. Remove the Engine Oil Cooler (4).
Refer to "ENGINE SHOP MANUAL".

INSTALLATION

Install engine oil cooler in reverse order of removal.

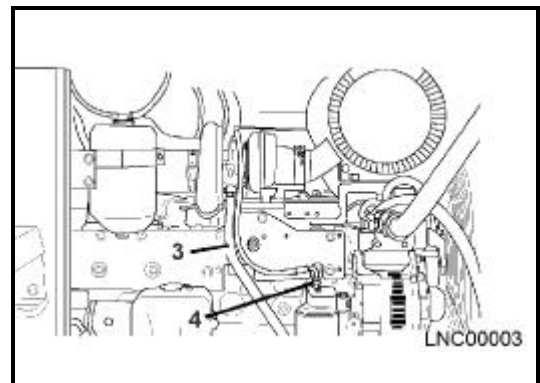
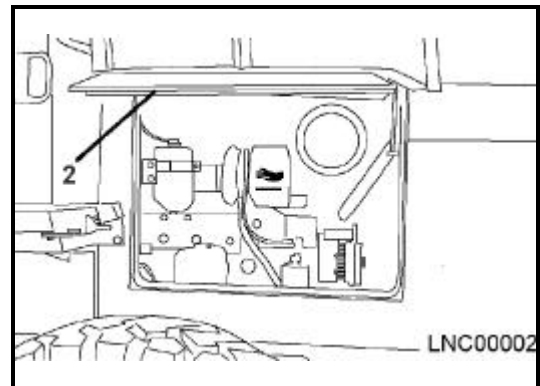
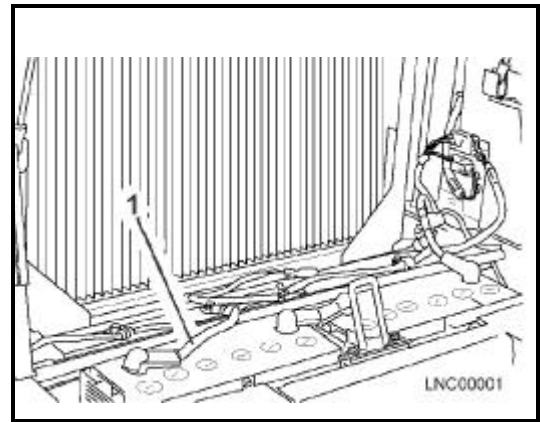

WATER PUMP



WARNING! Stop the machine on level ground and install the safety bar on the frame. Lower the bucket to the ground and stop the engine. Then apply the parking brake and put blocks under the wheels to prevent the machine from moving.



WARNING! Disconnect the cable from the negative (-) terminal (1) of the battery.

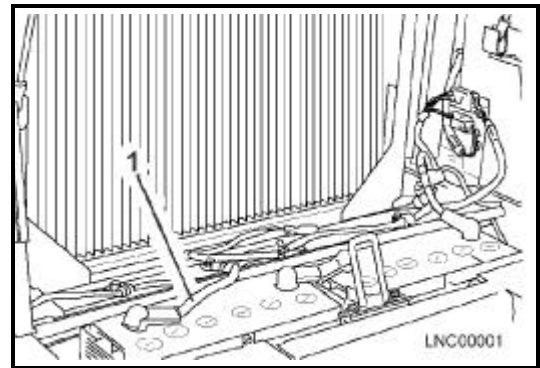

REMOVAL

1. Open engine hood left side cover and lock into position.
2. Drain water system (coolant) (2). Refer to "OPERATION & MAINTENANCE MANUAL".
3. Remove the Fan Belt from the Alternator and Belt Tensioner. Refer to "ALTERNATOR ASSEMBLY".
4. Remove the alternator. Refer to "ALTERNATOR ASSEMBLY".
5. Remove the Water Pump (3). Refer to "ENGINE SHOP MANUAL".

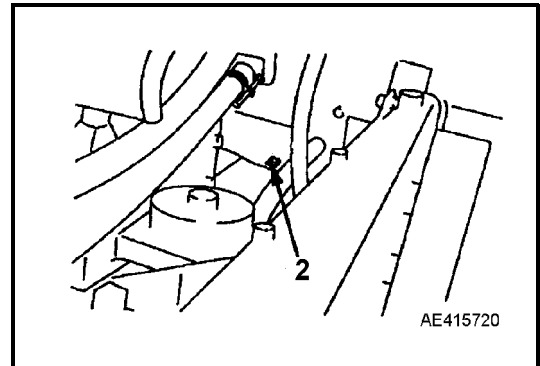

INSTALLATION

Install the water pump assembly in reverse order of removal. Refer to "ENGINE SHOP MANUAL".

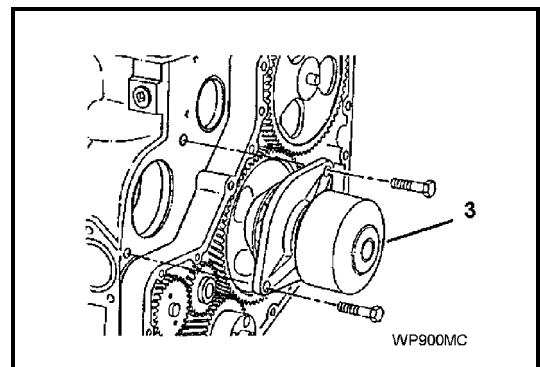

NOZZLE HOLDER



WARNING! Stop the machine on level ground and install the safety bar on the frame. Lower the bucket to the ground and stop the engine. Then apply the parking brake and put blocks under the wheels to prevent the machine from moving.

REMOVAL

1. Remove hood.
Refer to "HOOD REMOVAL".
2. Remove air cleaner (1) and bracket (2).
Refer to "AIR CLEANER".
3. Remove muffler (3) and mount bracket (4).
Refer to "MUFFLER".

NOTE: When the muffler bracket is removed, the air conditioner compressor and mount bracket comes off with it.

4. Remove turbocharger crossover tube (5) (air intake).
5. Remove nozzle holder (6).
Refer to "ENGINE SHOP MANUAL".

INSTALLATION

Install nozzle holder in reverse order of removal. Refer to "ENGINE SHOP MANUAL".

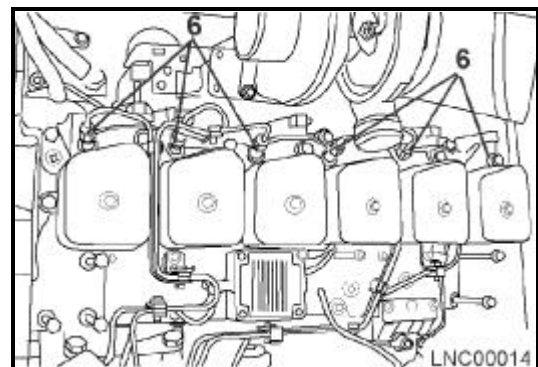
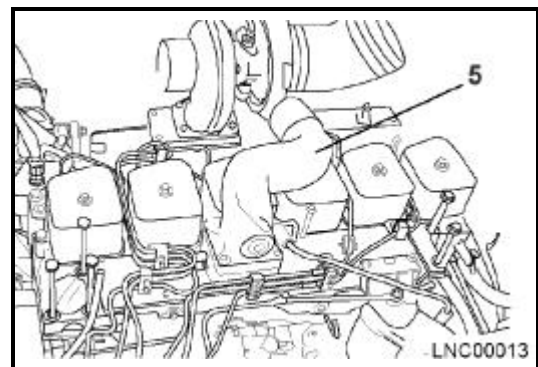
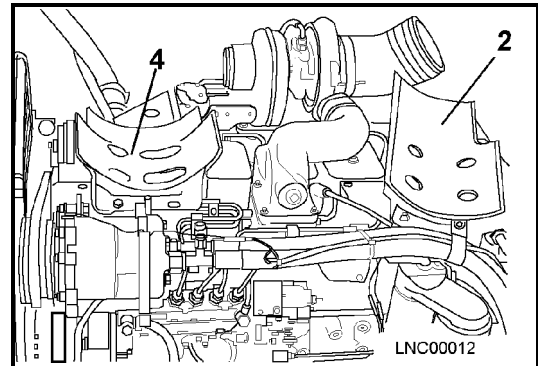
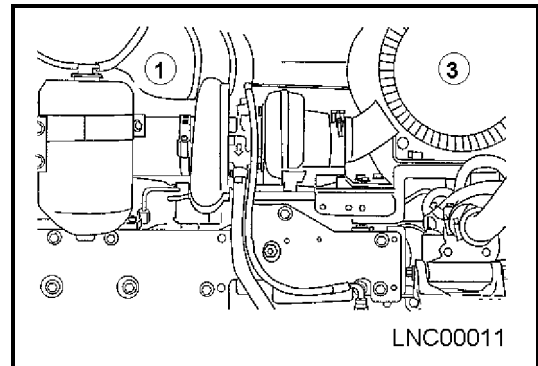

THERMOSTAT



WARNING! Stop the machine on level ground and install the safety bar on the frame. Lower the bucket to the ground and stop the engine. Then apply the parking brake and put blocks under the wheels to prevent the machine from moving.

REMOVAL

1. Drain water system of coolant (2).
Refer to "OPERATION & MAINTENANCE MANUAL".
2. Open engine hood, left side.
3. Disconnect screw clamp on thermostat and remove hose connection (3).
4. Remove thermostat.
Refer to "ENGINE SHOP MANUAL".

INSTALLATION

Install thermostat in reverse order of removal. Refer to "ENGINE SHOP MANUAL".

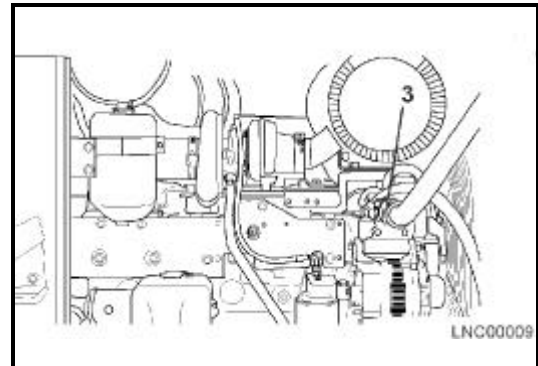
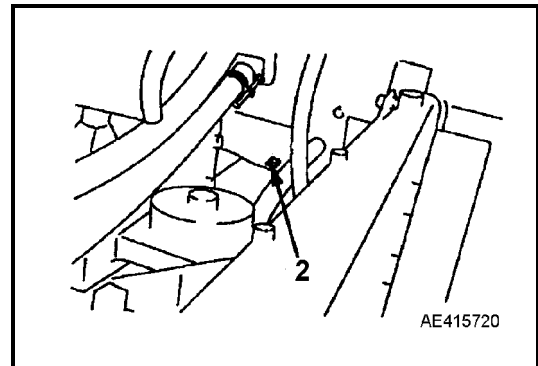

TURBOCHARGER



WARNING! Stop the machine on level ground and install the safety bar on the frame. Lower the bucket to the ground and stop the engine. Then apply the parking brake and put blocks under the wheels to prevent the machine from moving.

REMOVAL

1. Open engine hood left side cover and lock into position (2).
2. Remove heat shield (3).
3. Disconnect muffler clamp (4), air intake clamp (5), oil drain line (6) and oil lube line (7).
4. Remove turbocharger.
Refer to "ENGINE SHOP MANUAL".

INSTALLATION

Install turbocharger assembly in reverse order of removal. Refer to "ENGINE SHOP MANUAL".

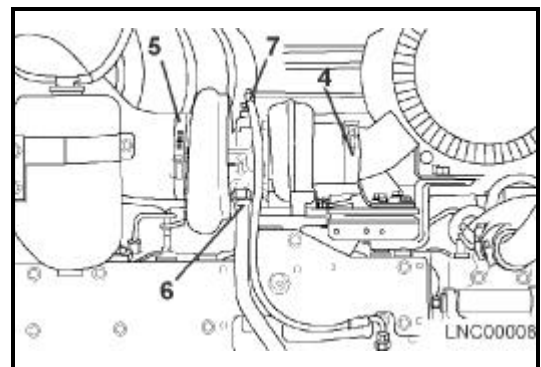
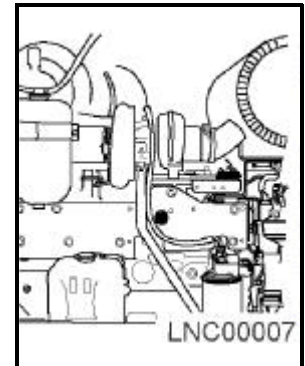
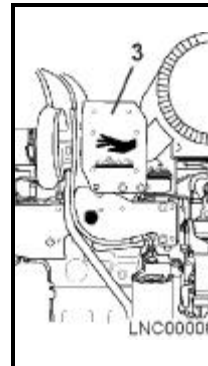
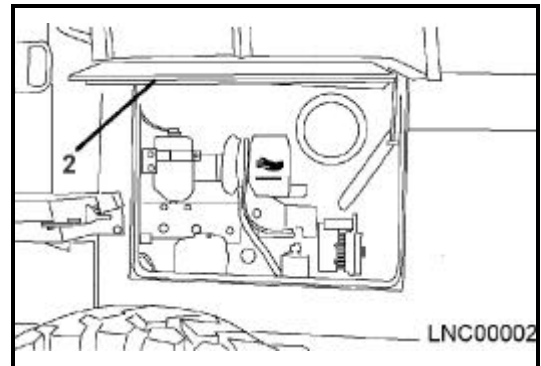

CYLINDER HEAD



WARNING! Stop the machine on level ground and install the safety bar on the frame. Lower the bucket to the ground and stop the engine. Then apply the parking brake and put blocks under the wheels to prevent the machine from moving.

REMOVAL

1. Remove hood.
Refer to "HOOD REMOVAL".
 2. Remove air cleaner (1) and bracket (4).
Refer to "AIR CLEANER".
 3. Remove muffler (3) and mount bracket (2).
Refer to "MUFFLER".
- NOTE:** When the muffler bracket is removed, the air conditioner compressor and mount bracket comes off with it.
4. Remove turbocharger crossover tube (air intake).
 5. Remove cylinder head.
Refer to "ENGINE SHOP MANUAL".

INSTALLATION

Install cylinder head in reverse order of removal. Refer to "ENGINE SHOP MANUAL".

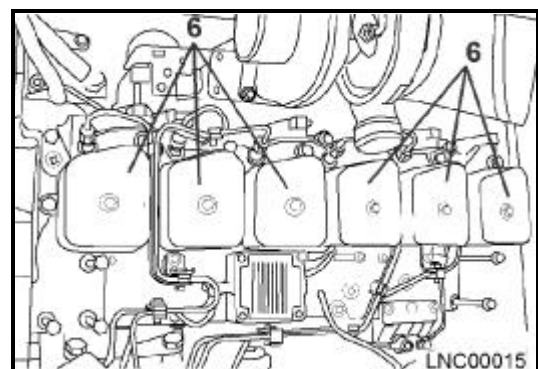
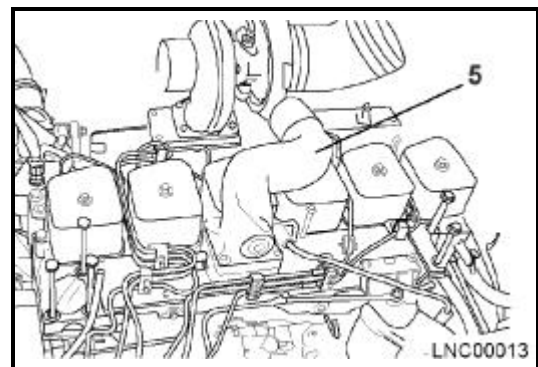
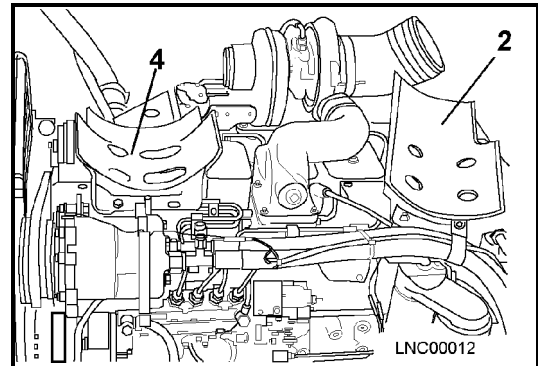
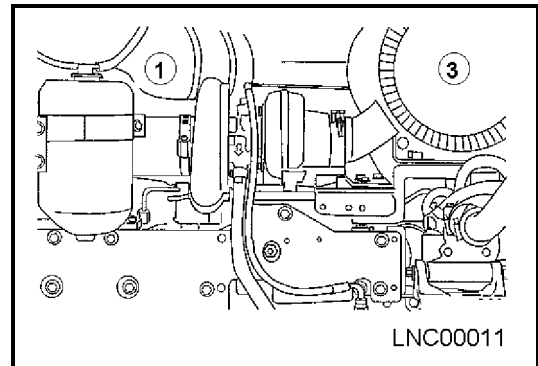

RADIATOR



WARNING! Stop the machine on level ground and install the safety bar on the frame. Lower the bucket to the ground and stop the engine. Then apply the parking brake and put blocks under the wheels to prevent the machine from moving.



WARNING! Loosen the oil cap slowly to release the pressure inside the hydraulic tank. Then operate the control levers several times to release the remaining pressure in the hydraulic piping.

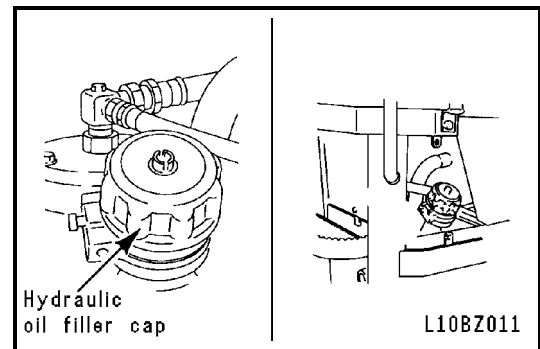

REMOVAL

1. Engine hood and side covers.

Refer to "REMOVAL OF ENGINE HOOD".

2. DRAINING COOLANT

Loosen radiator cap (1) to release internal pressure, and open drain valve (2) and drain coolant from system.

When system is drained close the drain valve.

If the coolant contains antifreeze, dispose of it properly.



Coolant: 35 (9.2 US gals)

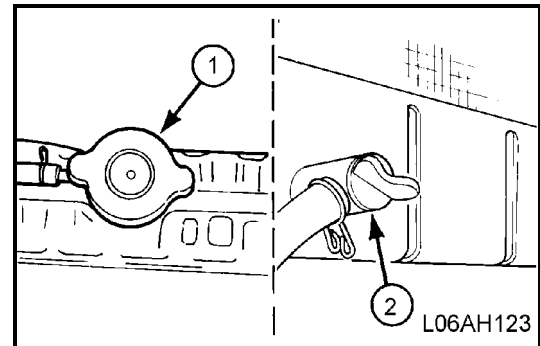

3. Fan guards.

- A) Remove left fan guard (3) and right fan guard (3A).
Be careful not to damage radiator fins.

4. Rear cover.

- A) Remove cover (4) at the bottom rear of the radiator.

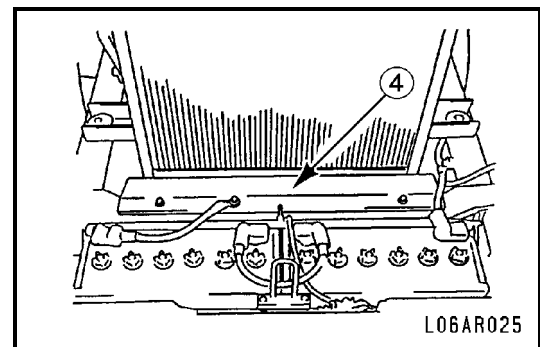
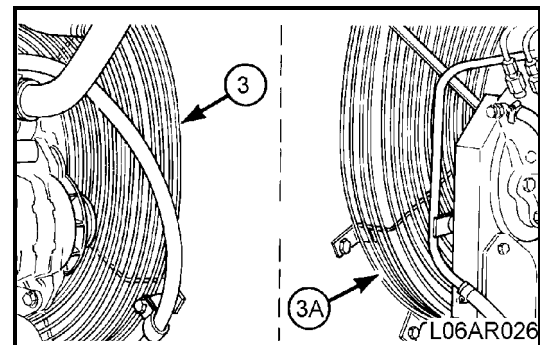

5. Removal of cooling lines.

- A) Close petcock (5) to shut off heater hose, remove lower radiator outlet tube (6) with hoses.

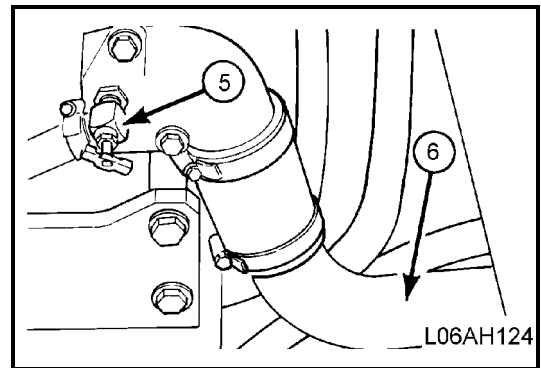

- B) Disconnect engine vent line (7), remove radiator inlet tube (8), and disconnect roading trans cooler line (9) from thermostat housing.

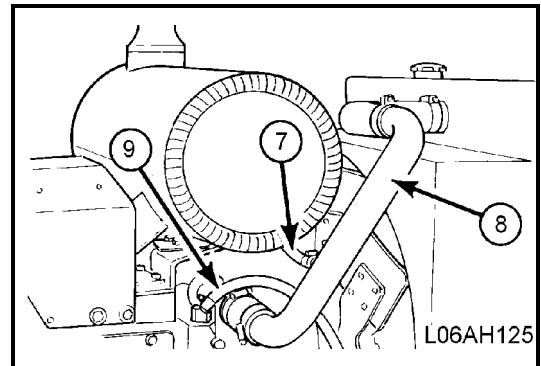

- C) Disconnect torque converter cooler hoses (10) and (11) from radiator bottom tank.

Radiator fan shroud may have to be disconnected from radiator and pushed aside to disconnect hoses (10) and (11).

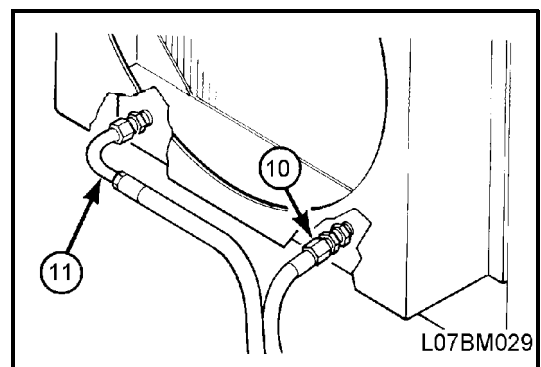
**6. Radiator removal.**

- A) Disconnect radiator stay rod (12) at radiator, loosen at frame and rotate forward.

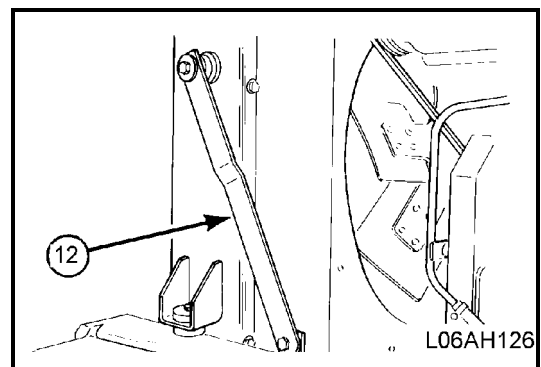

- B) Install lifting eyes (13) and hook up hoist, remove radiator mounting bolts and rubber mounts (14), and lift radiator assembly from machine.



Radiator: 110 lbs (50 kg)

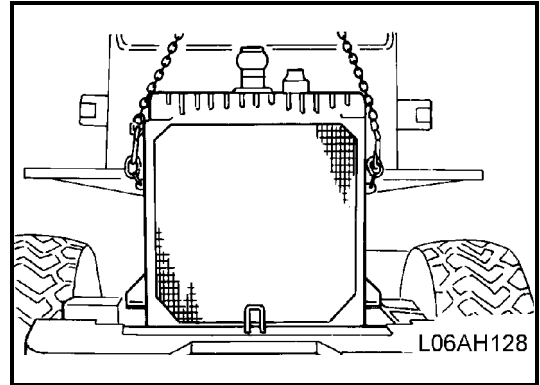
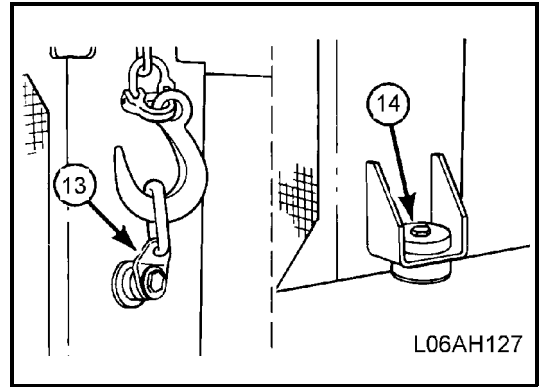

INSTALLATION

Install radiator in reverse order of removal.

Be careful not to damage the fins on the radiator assembly.

Adjust so that the clearance between the shroud and fan is uniform.

Install so that the clearance between fan and fan guard is uniform

Temporarily tighten the mounting bolts and fix the position, then tighten fully.

When installing the radiator, the difference in the clearance between the fan and radiator on the left and right must be within 3mm (0.118").

Install so that the clearance between the radiator fins and the front face of the fan is uniform at the top, bottom, left, and right.

The difference between the left and right in the position of the radiator in the front-to-rear direction must be within 5mm ((0.197").

Tighten hoses without twisting.



Radiator mounting bolts:
 82 ± 8 lbf.ft
 $(112.8 \pm 9.8 \text{ Nm})$
 $(11.5 \pm 1.0 \text{ kgm})$



Radiator support mounting bolts:
 82 ± 8 lbf.ft
 $(112.8 \pm 9.8 \text{ Nm})$
 $(11.5 \pm 1.0 \text{ kgm})$



Torque converter cooler hoses:
 130 ± 22 lbf.ft
 $(176.4 \pm 29.4 \text{ Nm})$
 $(18.0 \pm 3.0 \text{ kgm})$

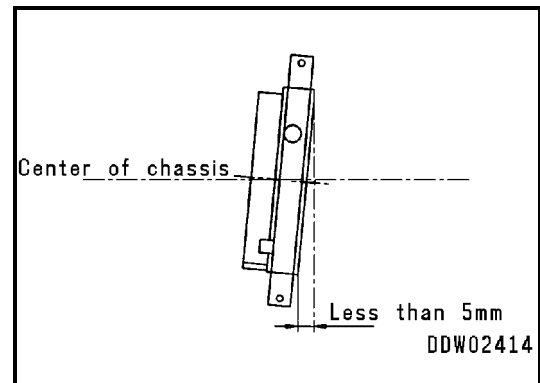

ENGINE



WARNING! Stop the machine on level ground and install the safety bar on the frame. Lower the bucket to the ground and stop the engine. Then apply the parking brake and put blocks under the wheels to prevent the machine from moving.



WARNING! Loosen the oil cap slowly to release the pressure inside the hydraulic tank. Then operate the control levers several times to release the remaining pressure in the hydraulic piping.



WARNING! Disconnect the cable from the negative (-) terminal of the battery.

REMOVAL

1. Engine hood and side covers.

Refer to "REMOVAL OF ENGINE HOOD".

2. Radiator and piping.

Refer to "REMOVAL OF RADIATOR".

3. Machines with Air Conditioning.

Note: There are shims (A) and (B) at bottom mounting bolt between welded spacer and compressor. When removing keep shims as they were removed.

- A) Disconnect wire (1) from harness at top of compressor, loosen lower mounting bolt (2) and adjusting bolt (3) allowing for removal of compressor belt (4).
- B) Unclip compressor lines (5) at air cleaner, and cut tie straps (6).
- C) Remove hardware (2) and (7), keeping in mind the aforementioned shims and position the compressor out of way.

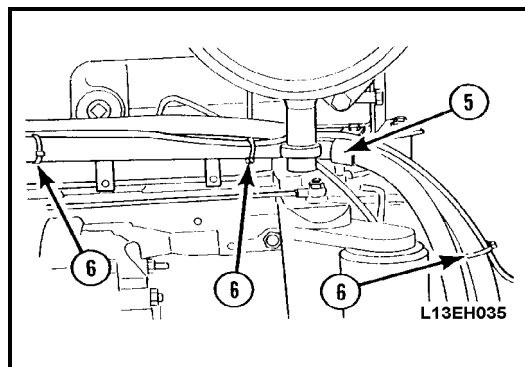
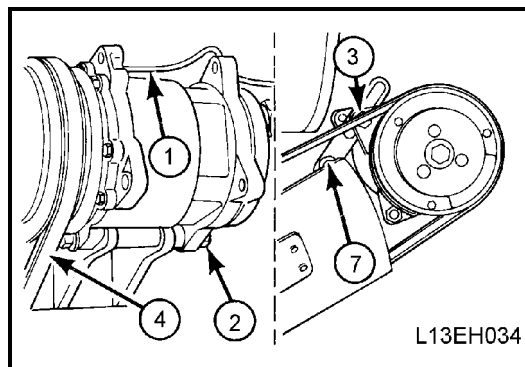
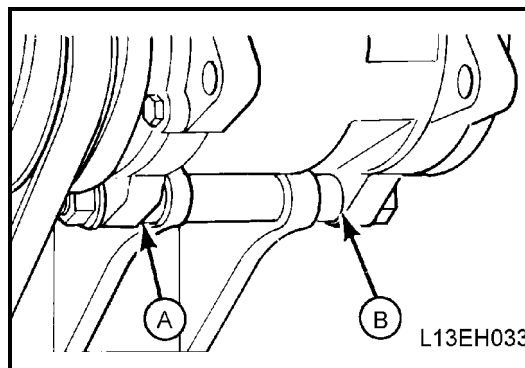
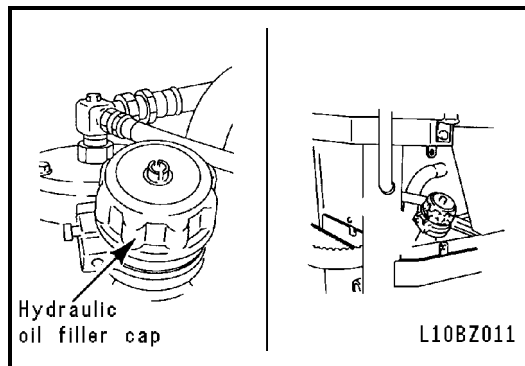

4. Right side of engine.

- A) Disconnect fuel inlet hose (8) and fuel outlet hose (9) and remove muffler drain tube (10).

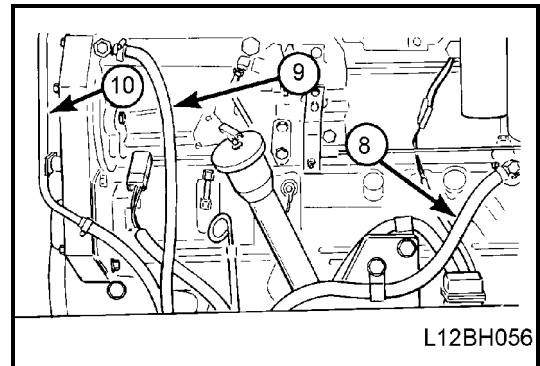

- B) Disconnect the fuel cut-off sensor (11), oil pressure switch (12), and coolant lead (13). Unclamp harness at clamp (14).

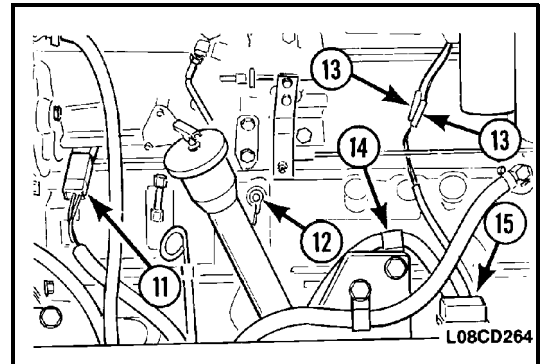

- C) Remove slow-blow fuse (15) from mounting bracket (16), open side door of fuse and disconnect harness lead (17). Replace screw, close door, and place fuse back in mounting bracket.

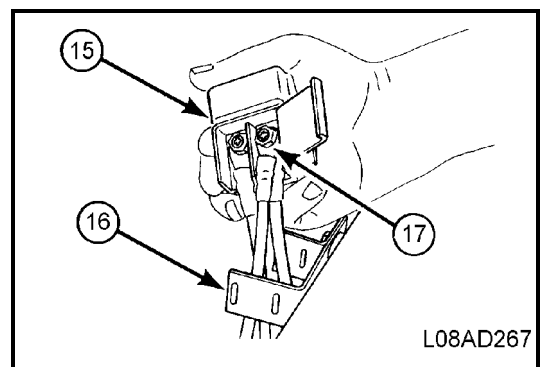

- D) At intake manifold, disconnect heat switch cable (18) and unclamp at air cleaner bracket (19), and remove cable from frame relay (20).

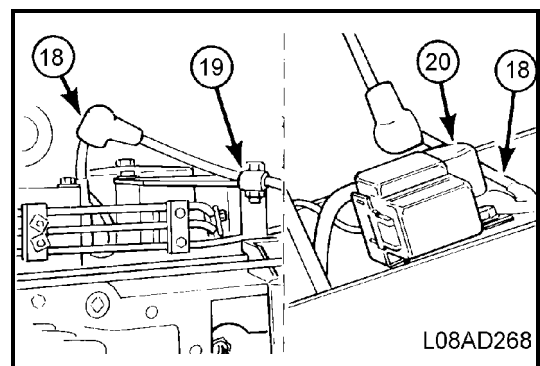

- E) Unclip engine harness from floor harness (21).

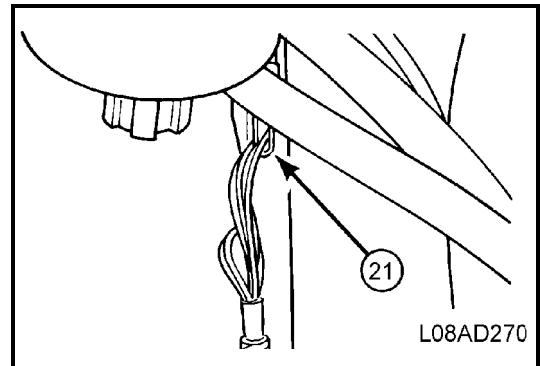

- F) Unclip harness and cranking motor cable at throttle bracket (22) at rear of engine (23), and shut off petcock (24), and disconnect heater hose (25).

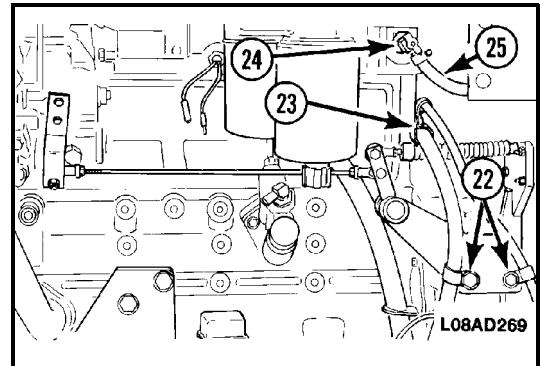

- G) Disconnect throttle linkage rod at fuel pump lever (26), remove throttle bracket (22) and position assembly out of way.

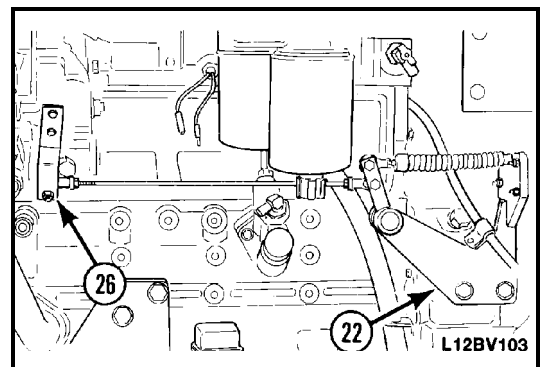

- H) Remove remote engine oil drain bracket (27) from trunnion.

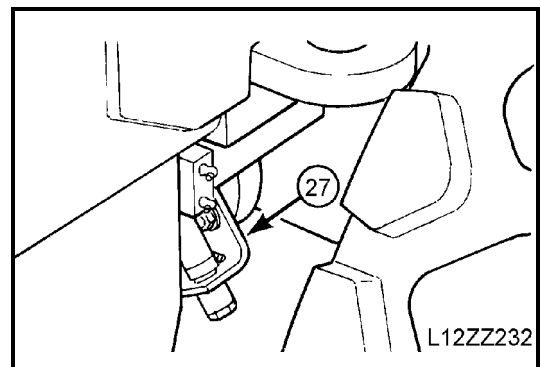

5. Left side of engine.

- A) Disconnect fuel sending unit (28), remove output (29), ground (30) leads from back of alternator, and water temperature switch (31).

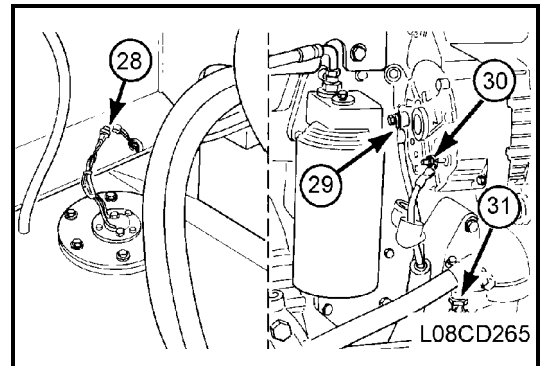

- B) Disconnect harness ground cable (32), remove starter relay and bracket (33) from engine block.

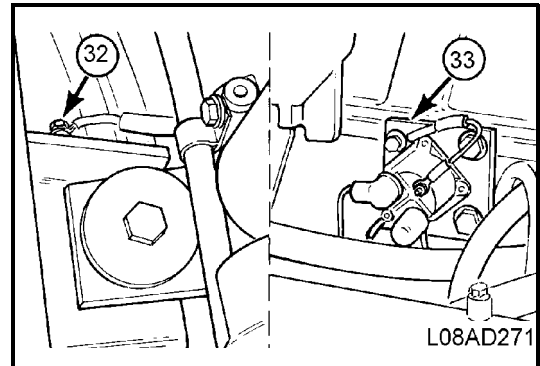

- C) Cut tie straps (34), remove mounting bolts from washer tank and bracket (35), and position out of way. Disconnect cranking motor leads (36) and (37).

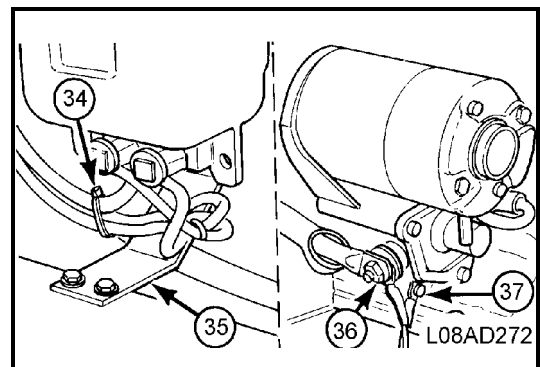

- D) Slide harness connector (38) from flywheel housing bracket and disconnect and remove engine harness. Disconnect cranking motor ground cable (39) at frame.

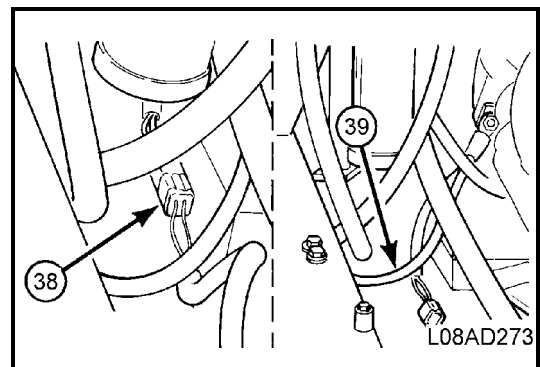



Download the full PDF manual instantly.

Our customer service e-mail:

aservicemanualpdf@yahoo.com