

Shop Manual

PC5500-6

HYDRAULIC MINING SHOVEL

SERIAL NUMBERS **PC5500-6 15031,15035 & UP**

This material is proprietary to Komatsu Mining Germany GmbH and is not to be reproduced, used, or disclosed except in accordance with written authorization from Komatsu Mining Germany GmbH.

It is our policy to improve our products whenever it is possible and practical to do so. We reserve the right to make changes or improvements at any time without incurring any obligation to install such changes on products sold previously.

Due to this continuous program of research and development, revisions may be made to this publication. It is recommended that customers contact their distributor for information on the latest revision.

Copyright 2006 Komatsu
Printed in U.S.A.
Komatsu Mining Germany

December 2006

CONTENTS

TABLE OF CONTENTS

- 00 Safety - Foreword**
- 01 Technical DATA (Leaflet)**
- 02 Assembly PROCEDURE (Brochure)**

Section

- 1. Main assembly groups**
- 2. Drive.**
- 3. Hydraulic oil tank.**
- 4. Hydraulic oil cooling.**
- 5. Controlling.**
- 6. Components**
- 7. Main hydraulic pumps and pump regulation.**
- 8. Operating hydraulic.**
- 9. Hydraulic track tensioning system.**
- 10. Hydraulic operated access ladder**
- 11.**
- 12. Hints for the hydraulic circuit diagram**
- 13. Hints for the electric circuit diagram**
- 14. ECS-T**
- 15. Lubrication Systems**

APPENDIX



- **Each section includes a detailed table of contents.**

SAFETY

SAFETY NOTICE

- **IMPORTANT SAFETY NOTICE**

Proper service and repair is extremely important for safe machine operation. The service and repair techniques recommended by Komatsu and described in this manual are both effective and safe. Some of these techniques require the use of tools specially designed by Komatsu for the specific purpose.

The following Symbols are used in this Manual to designate Instructions of particular Importance.



WARNING - Serious personal injury or extensive property damage can result if the warning instructions are **not** followed.

To prevent injury to workers, this symbol is used to mark safety precautions in this manual. The cautions accompanying these symbols should always be followed carefully. If any dangerous situation arises or may possibly arise, first consider safety, and take the necessary actions to deal with the situation.



CAUTION - Minor personal injury can result or a part, an assembly, or the shovel can be damaged if the caution instructions are **not** followed.



NOTE - Refers to special information

GENERAL PRECAUTIONS

Mistakes in operation are extremely dangerous. Read the OPERATION & MAINTENANCE MANUAL carefully BEFORE operating the machine.

1. Before carrying out any greasing or repairs, read all the precautions given on the decals which are fixed to the machine.
2. When carrying out any operation, always wear safety shoes and helmet. Do not wear loose work clothes, or clothes with buttons missing.
 - Always wear safety glasses when hitting parts with a hammer.
 - Always wear safety glasses when grinding parts with a grinder, etc.

continued

Cont'd:**GENERAL PRECAUTIONS**

3. If welding repairs are needed, always have a trained, experienced welder carry out the work. When carrying out welding work, always wear welding gloves, apron, glasses, cap and other clothes suited for welding work.
4. When carrying out any operation with two or more workers, always agree on the operating procedure before starting. Always inform your fellow workers before starting any step of the operation. Before starting work, hang UNDER REPAIR signs on the controls in the operator's compartment.
5. Keep all tools in good condition and learn the correct way to use them.
6. Decide a place in the repair workshop to keep tools and removed parts. Always keep the tools and parts in their correct places. Always keep the work area clean and make sure that there is no dirt or oil on the floor. Smoke only in the areas provided for smoking. Never smoke while working.

PREPARATIONS FOR WORK

7. Before adding oil or making repairs, park the machine on hard, level ground, and block the wheels or tracks to prevent the machine from moving.
8. Before starting work, lower bucket, hammer or any other work equipment to the ground. If this is not possible, insert the safety pin or use blocks to prevent the work equipment from falling. In addition, be sure to lock all the control levers and hang warning signs on them.
9. When disassembling or assembling, support the machine with blocks, jacks or stands before starting work.
10. Remove all mud and oil from the steps or other places used to get on and off the machine. Always use the handrails, ladders or steps when getting on or off the machine. Never jump on or off the machine. If it is impossible to use the handrails, ladders or steps, use a stand to provide safe footing.

PRECAUTIONS DURING WORK

11. When removing the oil filler cap, drain plug or hydraulic pressure measuring plugs, loosen them slowly to prevent the oil from spurting out. Before disconnecting or removing components of the oil, water or air circuits, first remove the pressure completely from the circuit.
12. The water and oil in the circuits are hot when the engine is stopped, so be careful not to get burned.
Wait for the oil and water to cool before carrying out work on the oil or water circuits.

continued

Cont'd:

PRECAUTIONS DURING WORK

13. Before starting work, remove the leads from the battery. ALWAYS remove the lead from the negative (-) terminal first.
14. When raising heavy components, use a hoist or crane.
Check that the wire rope, chains and hooks are free from damage.
Always use lifting equipment which has ample capacity.
Install the lifting equipment at the correct places. Use a hoist or crane and operate slowly to prevent the component from hitting any other part. Do not work with any part still raised by the hoist or crane.
15. When removing covers which are under internal pressure or under pressure from a spring, always leave two bolts in position on opposite sides. Slowly release the pressure, then slowly loosen the bolts to remove.
16. When removing components, be careful not to break or damage the wiring, Damaged wiring may cause electrical fires.
17. When removing piping, stop the fuel or oil from spilling out. If any fuel or oil drips on to the floor, wipe it up immediately. Fuel or oil on the floor can cause you to slip, or can even start fires.
18. As a general rule, do not use gasoline to wash parts.
19. Be sure to assemble all parts again in their original places. Replace any damaged part with new parts.
 - When installing hoses and wires, be sure that they will not be damaged by contact with other parts when the machine is being operated.
20. When installing high pressure hoses, make sure that they are not twisted. Damaged tubes are dangerous, so be extremely careful when installing tubes for high pressure circuits. Also check that connecting parts are correctly installed.
21. When assembling or installing parts, always use the specified tightening torques. When installing protective parts such as guards, or parts which vibrate violently or rotate at high speed, be particularly careful to check that they are installed correctly.
22. When aligning two holes, never insert your fingers or hand. Be careful not to get your fingers caught in a hole.
23. When measuring hydraulic pressure, check that the measuring tool is correctly assembled before taking any measurements.
24. Take care when removing or installing the tracks of track-type machines. When removing the track, the track separates suddenly, so never let anyone stand at either end of the track.

FOREWORD

GENERAL

With this **SERVICE MANUAL** KOMATSU provides you with the description of the construction and the function of the major systems of the Hydraulic Excavator **PC5500-E**.

We describe for you all functions and how to carry out the inspections and adjustments.

How do you find "your" desired information?

In the table of CONTENT all the functions and components are shown in their sequence of the description.

If after reading this **SERVICE MANUAL** you can give us suggestions and comments for improvements - please do not hesitate to contact us.

Komatsu Mining Germany GmbH

- Service Training -
Postfach 180361
40570 Düsseldorf

Tel.:0211 / 7109 - 206
Fax.:0211 / 74 33 07

The editorial staff will be pleased about your co-operation.

- FROM THE PRACTICE - FOR THE PRACTICE -



- **This service manual corresponds to the state of development of the machine at the time the manual was produced.**
Variations based on special customers request and special equipment are not included in this manual

Table of contents section 1.0

Section		Page
1.0	Main assembly groups	
	General lay out	2
1.1	Superstructure	3
	1.1.1 Machine house	4
	1.1.2 Hydraulic Oil Reservoir	5
	1.1.3 Hydraulic Oil Cooler	6
	1.1.4 Fuel Tank	7
	1.1.5 Counter weight	8
	1.1.6 Cab support	9
	1.1.7 Operators cab	10
	1.1.8 Control Blocks	11
	1.1.9 Swing gears	12
1.2	Under carriage	13
1.3	Attachment	
	1.3.1. Backhoe Attachment (BHA)	14
	1.3.2. Front Shovel Attachment (FSA)	15

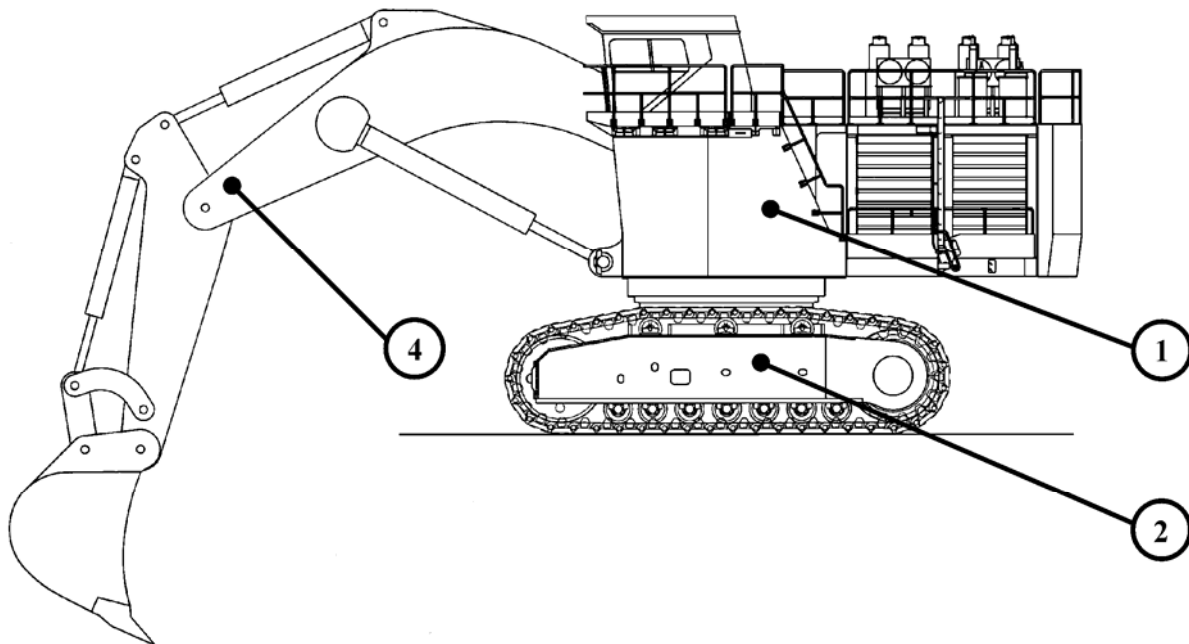
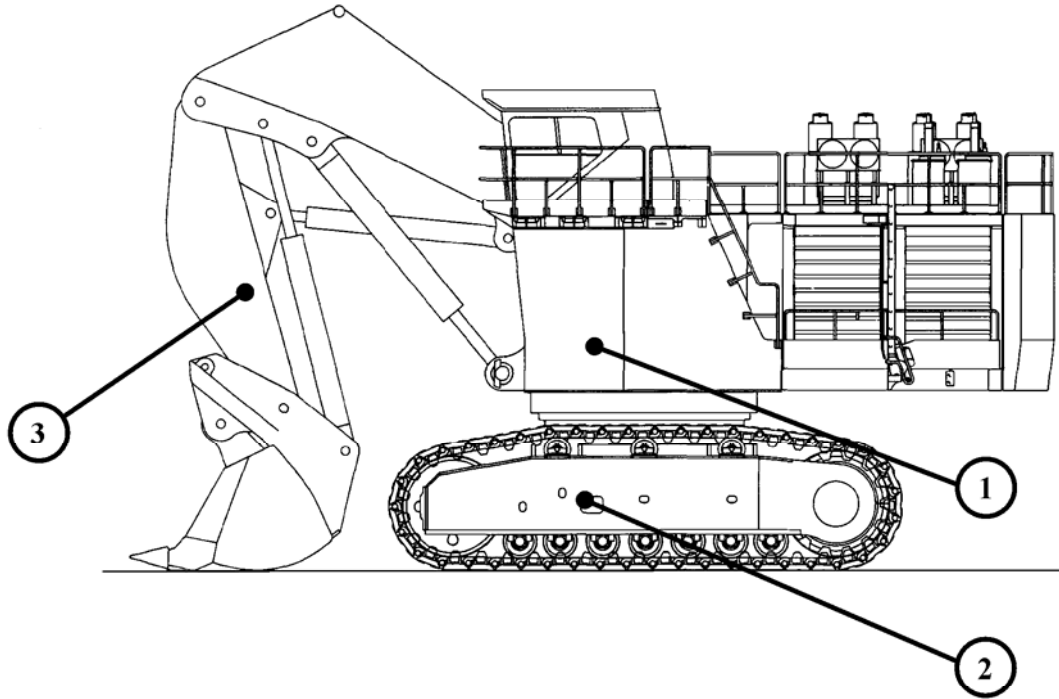

Z 22387

1. General layout**Legend for illustration (Z 22387):**

- (1) Superstructure
- (2) Under carriage
- (3) Front Shovel Attachment (FSA)
- (4) Backhoe Attachment (BHA)

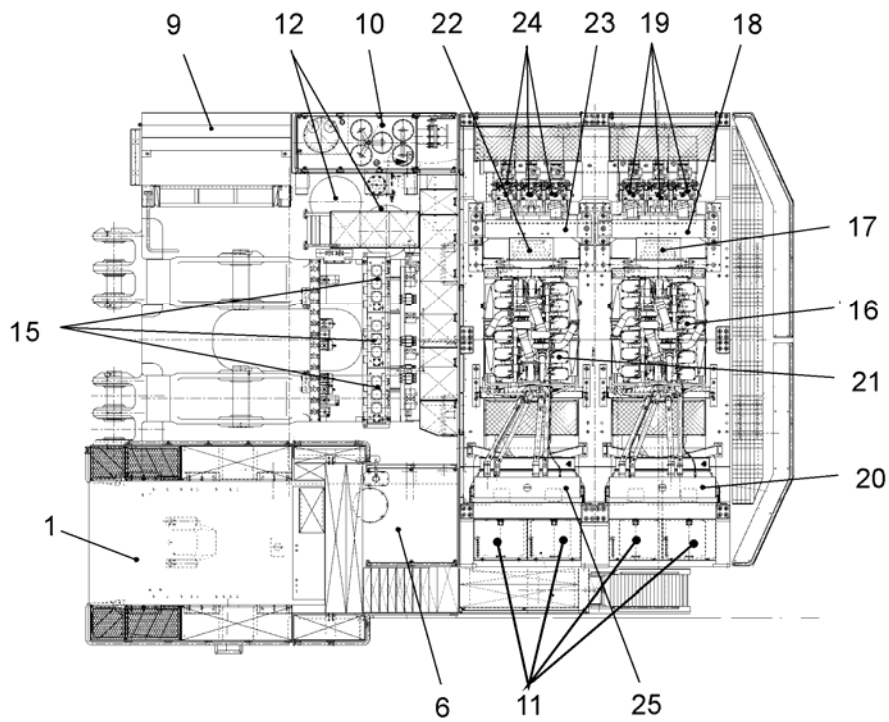
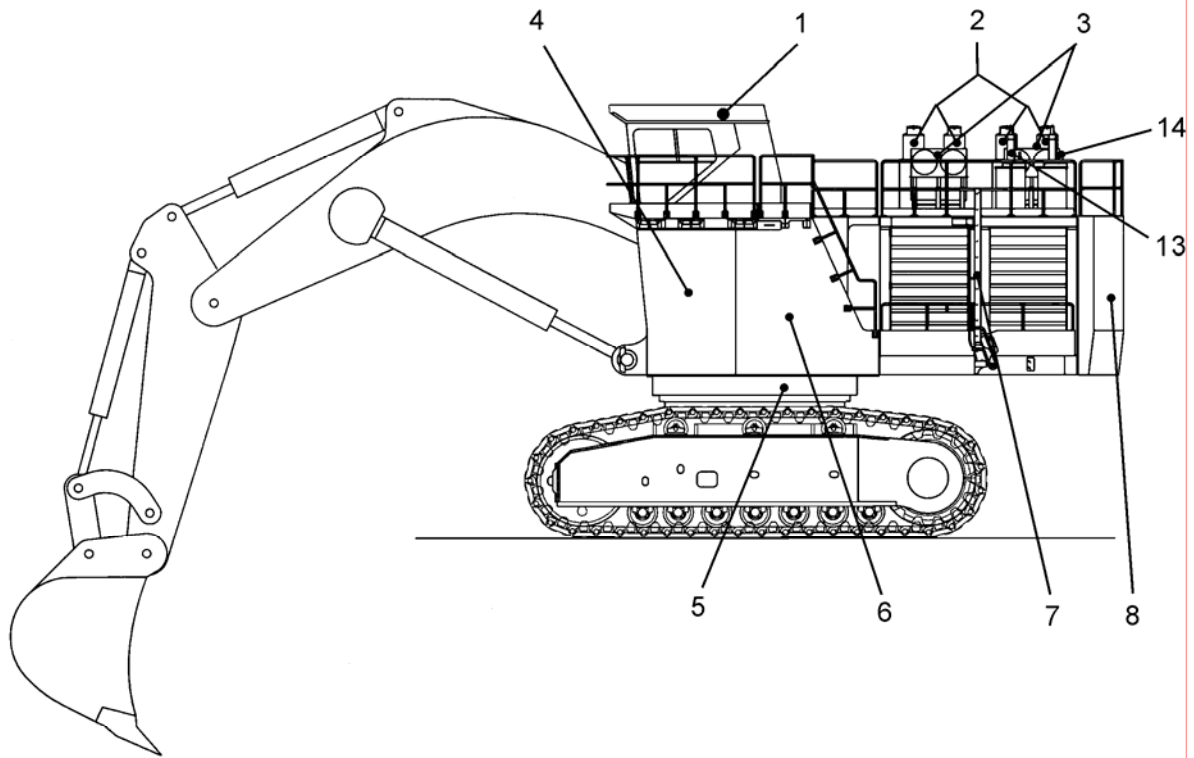

Z 22386

1.1 Superstructure

Legend for illustration (Z 22386):

- (1) Operators Cab with integrated FOPS.
- (2) Exhaust
- (3) Air cleaner
- (4) Cab support (contains the electrical switch board)
- (5) Swing ring connection
- (6) Fuel reservoir
- (7) Hydraulic ladder
- (8) Counter weight
- (9) Hydraulic oil cooler with hydraulic driven fans
- (10) Hydraulic oil reservoir
- (11) Batteries
- (12) Swing Gear
- (13) Grease pump of the Central Lubrication System
- (14) Grease pump of the Swing gear pinion Lubrication System
- (15) Main Control blocks with high pressure filters

- (16) Engine 1
- (17) Flexible coupling, oil filled
- (18) PTO gear with hydraulic pumps
- (19) Main hydraulic pumps 1, 2 and 3
- (20) Radiator for the engine cooling system

- (21) Engine 2
- (22) Flexible coupling, oil filled
- (23) PTO gear with hydraulic pumps
- (24) Main hydraulic pumps 4, 5 and 6
- (25) Radiator for the engine cooling system

View from the back site of machinerie hous
without counter wight

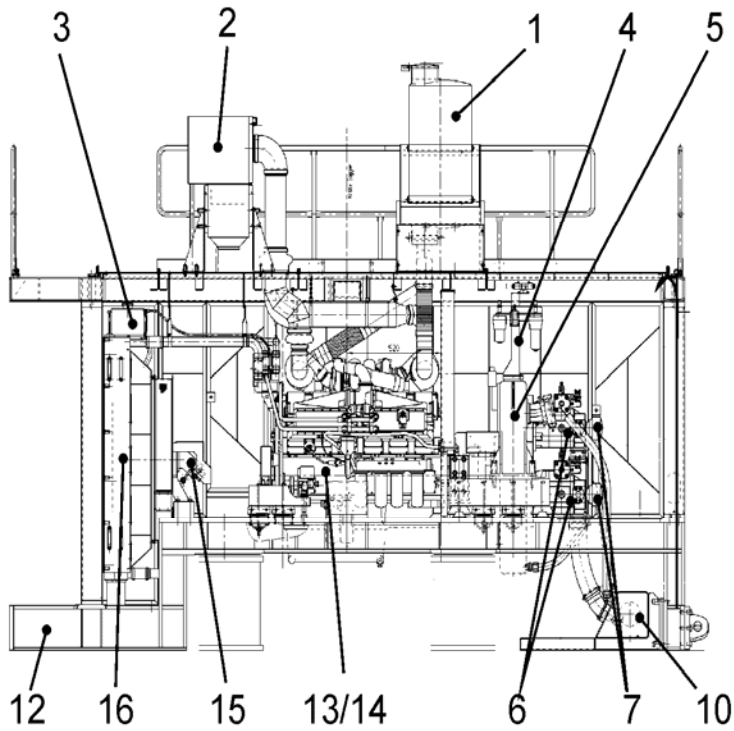

View form the right site of machinerie hous
without door

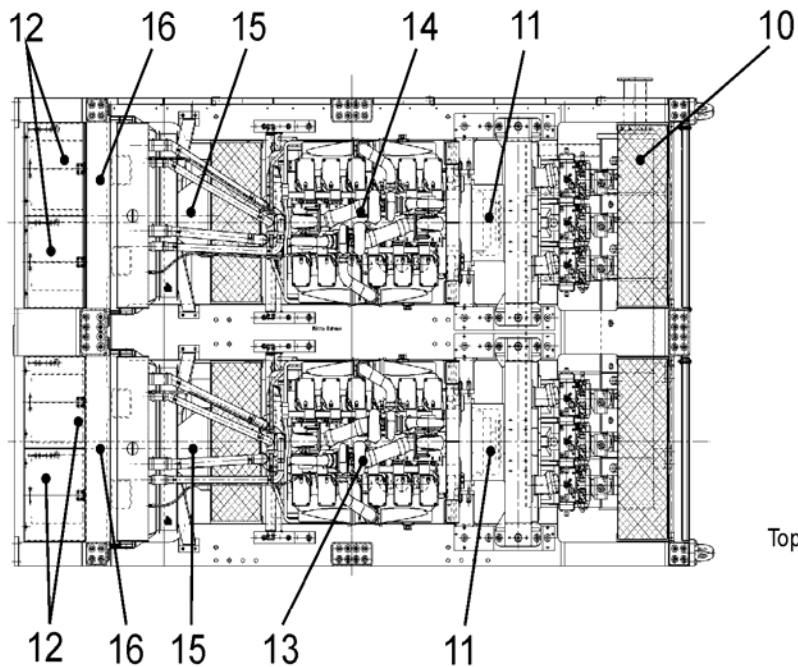
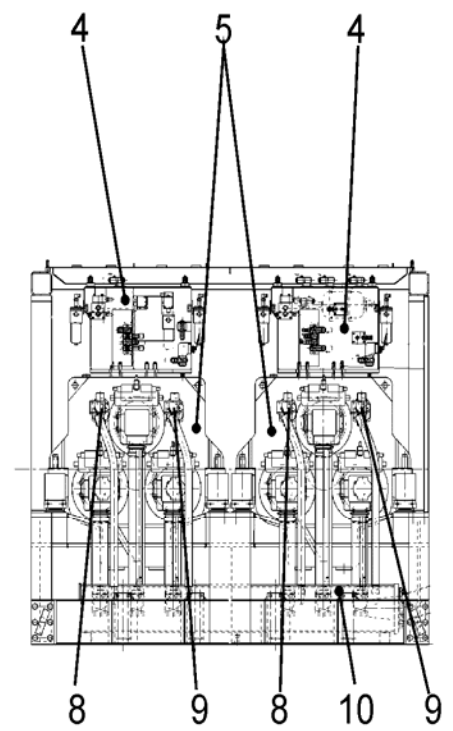

Top view

Z 22390

1.1 Superstructure

1.1.1 Machine house

Legend for illustration (Z 22390):

- (1) Roof mounted exhaust
- (2) Roof mounted air cleaners with restriction switches
- (3) Expansion tank of the radiator for the engine cooling system
- (4) Hydraulic control and filter panel
- (5) PTO gear box
- (6) Main hydraulic pumps
- (7) Auxiliary pumps, installed at the drive through shaft of the main hydraulic pumps (piggyback pumps)
- (8) Hydraulic pump for radiator fan drive
- (9) Hydraulic pump for the hydraulic oil cooler fan drive
- (10) Suction oil reservoir
- (11) Flexible coupling, oil filled
- (12) Batteries
- (13) Engine 1
- (14) Engine 2
- (15) Hydraulic motor for the radiator fan drive
- (16) Radiator for the engine cooling system

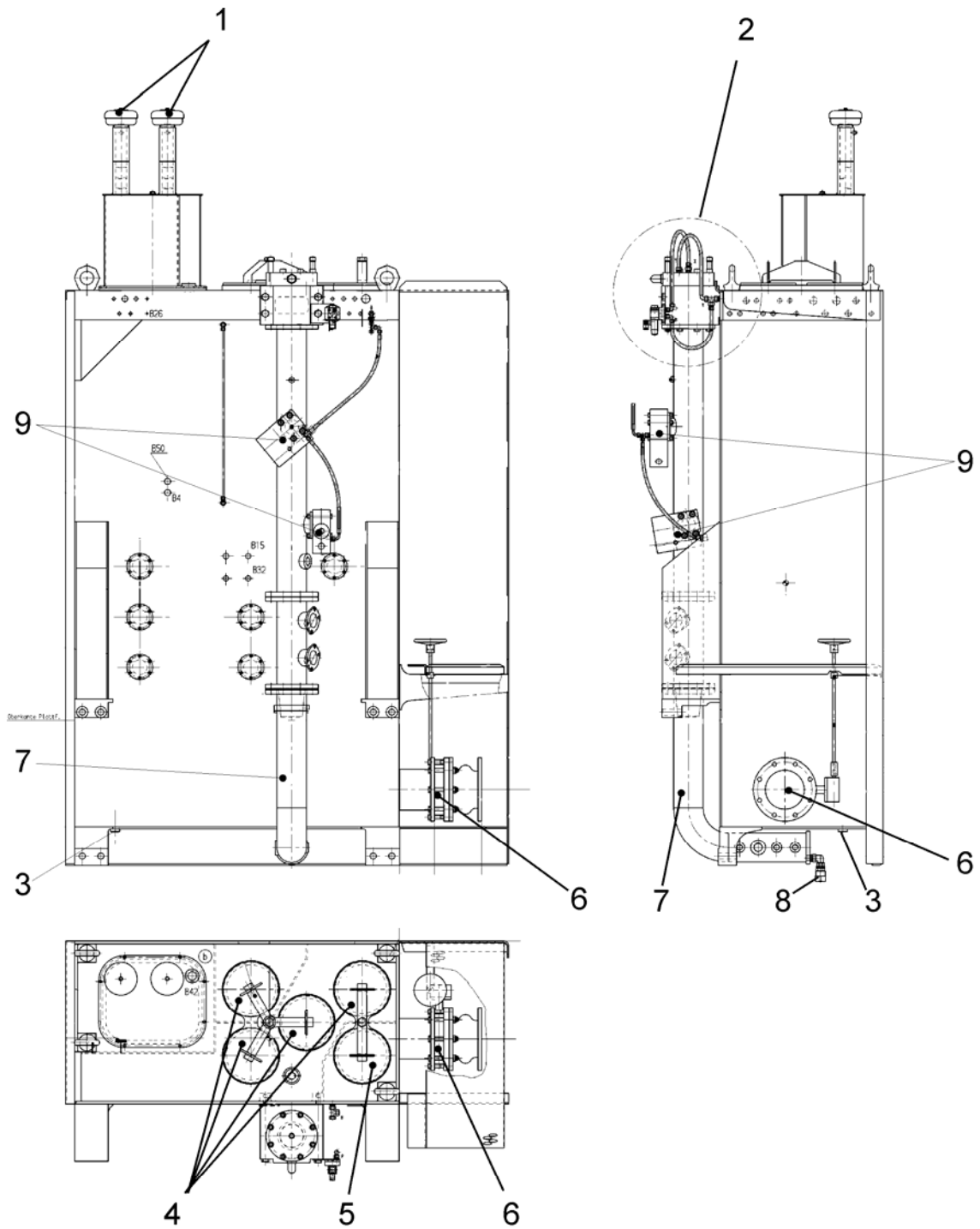

Z 22391a

1.1 Superstructure**1.1.2 Hydraulic Oil Reservoir****Legend for illustration (Z 22391):**

- (1) Breather filter
- (2) Temperature controlled back pressure valve
- (3) Drain coupling of the hydraulic oil reservoir
- (4) Return oil filter
- (5) Case drain (leak oil) filter
- (6) Main shut-off valve (Gate valve) with compensator
- (7) Return oil collector tube
- (8) Drain coupling of the Return oil collector tube
- (9) Back pressure valves for swing motors

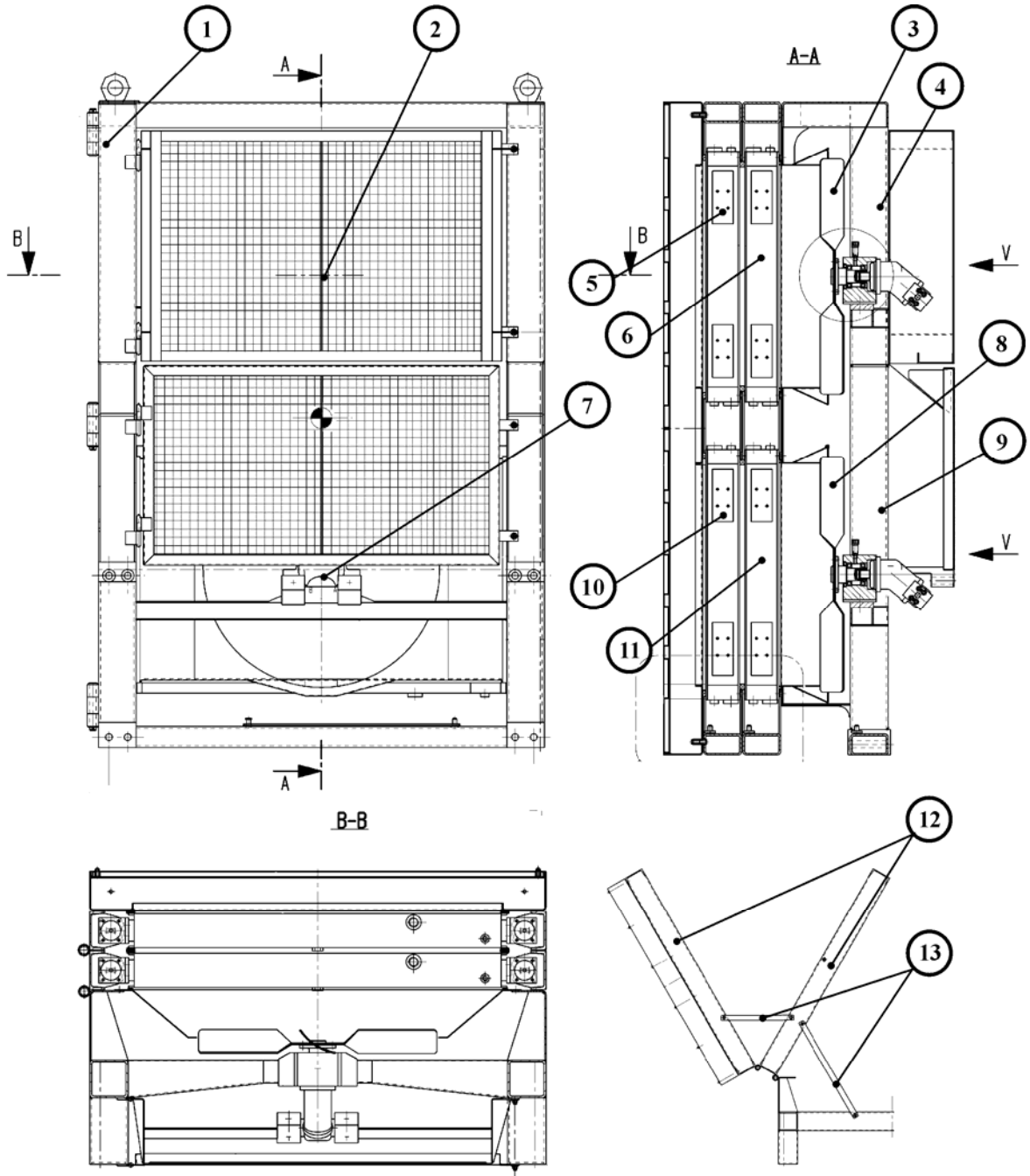

Z 22392

1.1 Superstructure**1.1.3 Hydraulic Oil Cooler****Legend for illustration (Z 22392):**

- (1) Cooler frame with swing out facility
- (2) Hydraulic motor of upper fan
- (3) Upper fan
- (4) Fan guard
- (5) Outer part of the upper radiator set
- (6) Inner part of the upper radiator set
- (7) Hydraulic motor of lower fan
- (8) Lower fan
- (9) Fan guard
- (10) Outer part of the lower radiator set
- (11) Inner part of the lower radiator
- (12) Swing out doors
- (13) Locking bars to secure the swing out doors

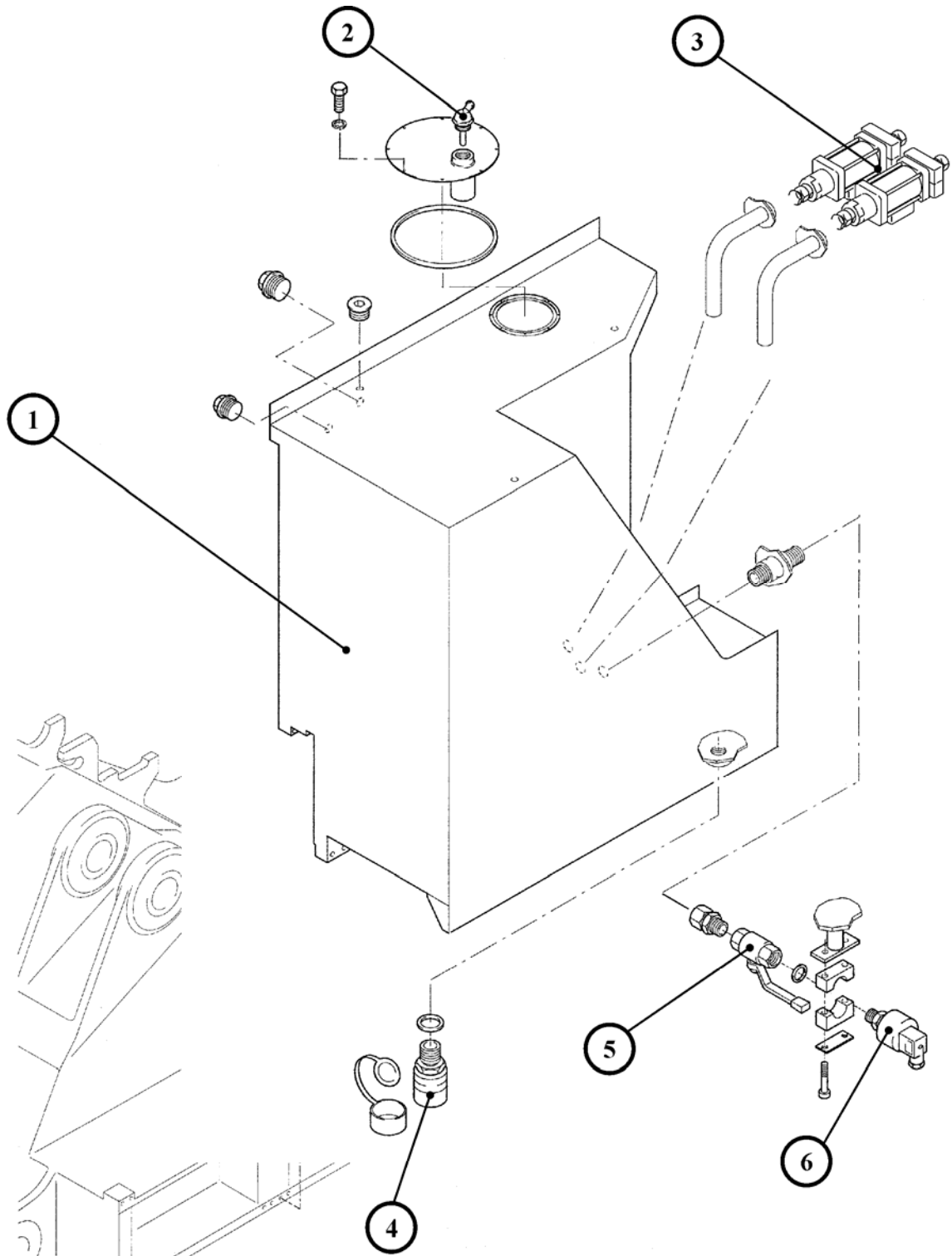

Z 21473 a

1.1 Superstructure**1.1.4 Fuel tank (Fuel reservoir)****Legend for illustration (Z 21473):**

- (1) Fuel tank
- (2) Fuel tank breather valve
- (3) Main shut-off solenoid valves
- (4) Drain coupling with protection cap
- (5) Shut-off cock for fuel pressure transducer
- (6) Fuel pressure transducer

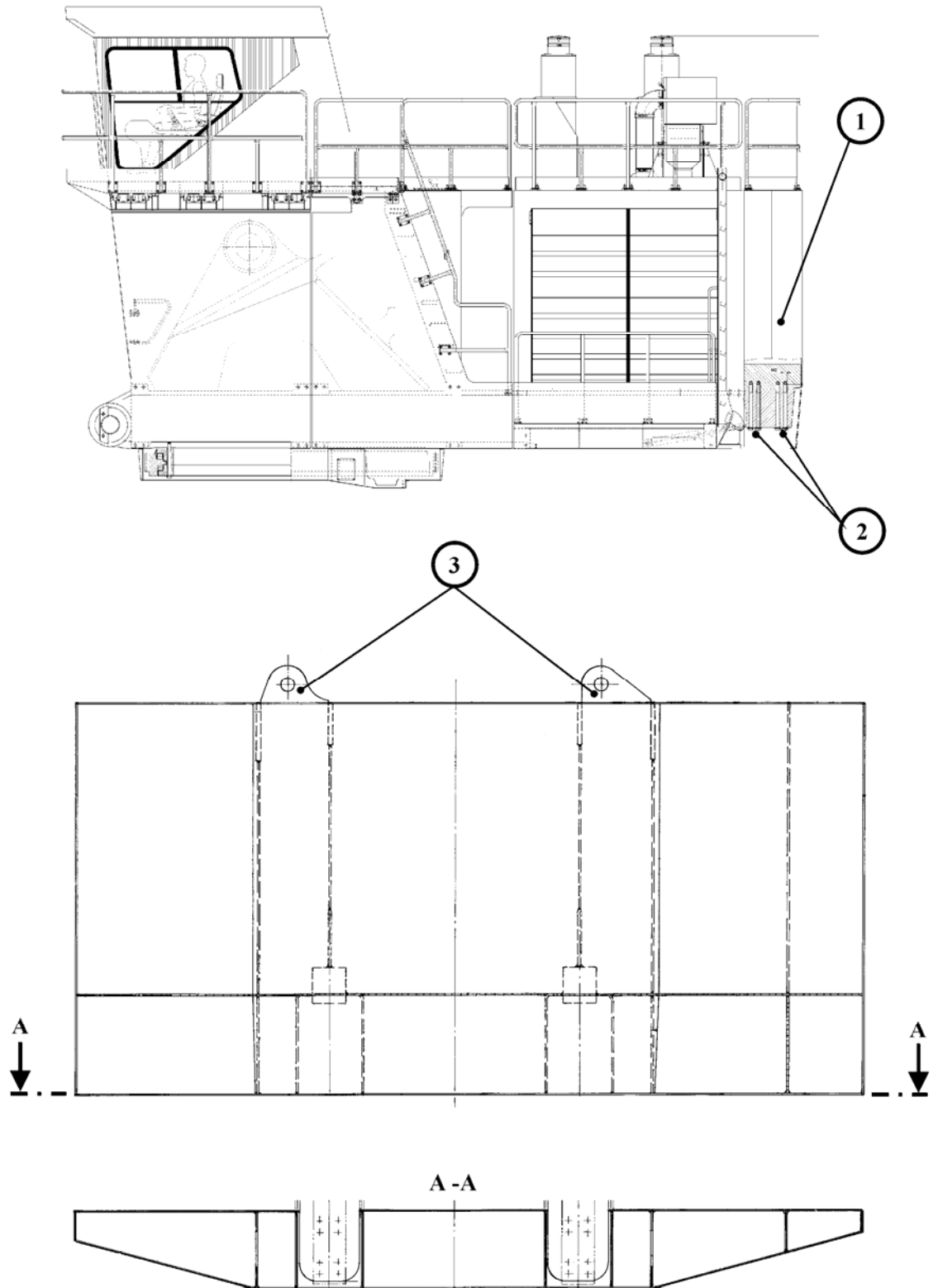

Z 21474

1.1 Superstructure**1.1.5 Counter weight****Legend for illustration (Z 21474):**

- (1) Counter weight

Total weight
40000 kg

- (2) Mounting bolts

Quantity	Bolt size (mm)	Grade	SW* (mm)	Tightening torque (Nm)
16	M 48 x 380	10.9	75	7500

* SW = Wrench size

- (3) Lifting points

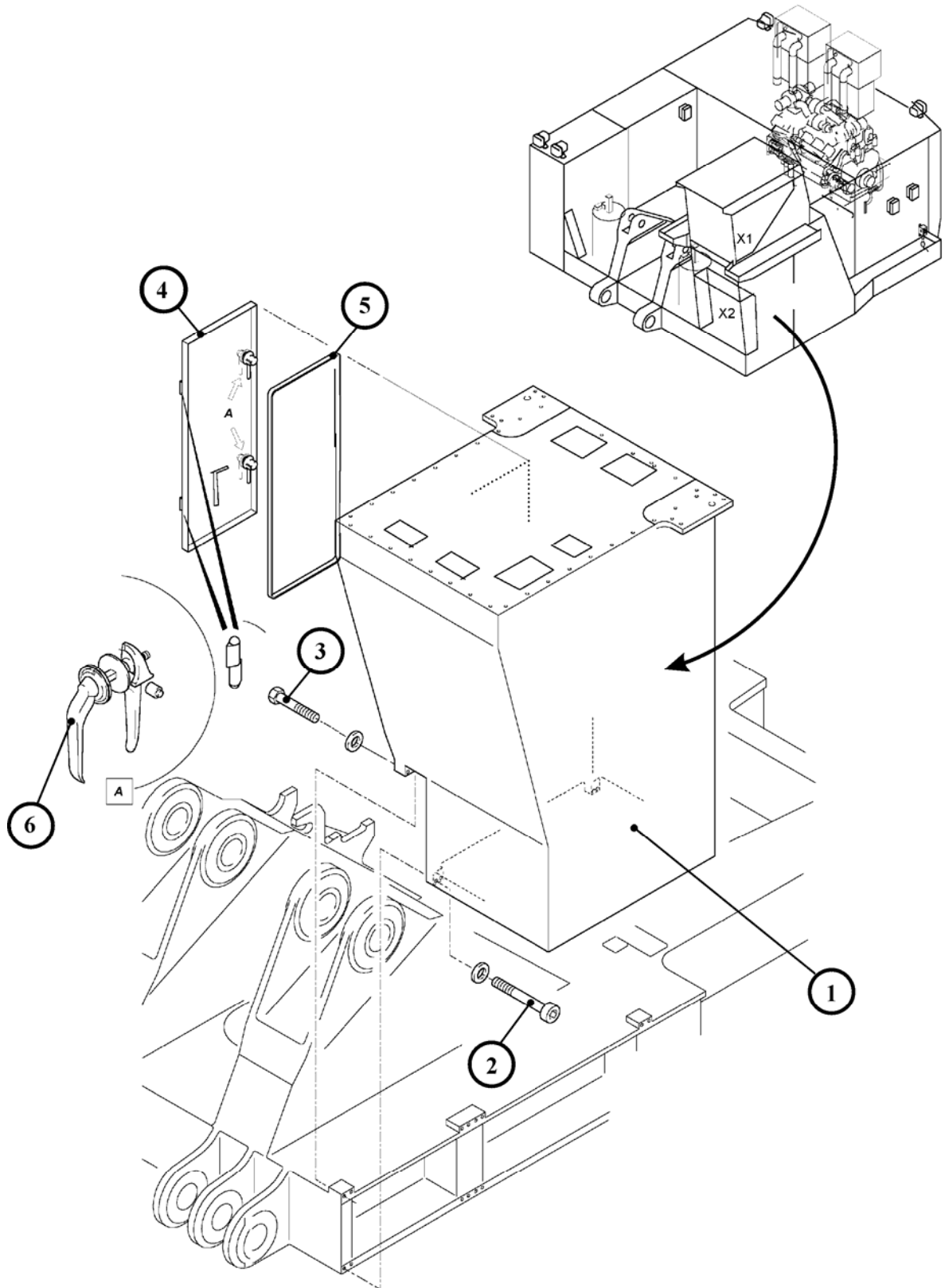

Z 21475

1.1 Superstructure**1.1.6 Cab support****Legend for illustration (Z 21475):**

(1) Cab support (Location of electrical switch board “X2”)

(2) Mounting bolts

Quantity	Bolt size (mm)	Grade	SW* (mm)	Tightening torque (Nm)
6	M 36 x 320	10.9	55	3100

*SW = Wrench size

(3) Mounting bolts

Quantity	Bolt size (mm)	Grade	SW* (mm)	Tightening torque (Nm)
6	M 36 x 160	10.9	55	3100

*SW = Wrench size

(4) Door

(5) Gasket

(6) Door handle (adjustable)



Download the full PDF manual instantly.

Our customer service e-mail:

aservicemanualpdf@yahoo.com