

Shop Manual

PC3000-1

HYDRAULIC MINING SHOVEL

SERIAL NUMBERS PC3000-1 6225

This material is proprietary to Komatsu Mining Germany GmbH and is not to be reproduced, used, or disclosed except in accordance with written authorization from Komatsu Mining Germany GmbH.

It is our policy to improve our products whenever it is possible and practical to do so. We reserve the right to make changes or improvements at any time without incurring any obligation to install such changes on products sold previously.

Due to this continuous program of research and development, revisions may be made to this publication. It is recommended that customers contact their distributor for information on the latest revision.

Copyright 2006 Komatsu
Printed in U.S.A.
Komatsu Mining Germany

Series 06192 -
Diesel engine driven ma-
chines

With this **SERVICE MANUAL** KOMATSU MINING GERMANY GmbH provides you with the description of the construction and the function of the major systems of the hydraulic excavator PC 3000.

We describe for you all functions and how to carry out the inspections and adjustments.

How do you find "your" desired information?

In the table of CONTENTS all the functions and components are shown in their sequence of the description.

If after reading this **SERVICE MANUAL** you can give us suggestions and comments for improvements - please do not hesitate to contact us.

KOMATSU MINING GERMANY GmbH
- Service Training -

Postfach 180361
40570 Düsseldorf
Tel.:0211 / 7109 - 206
Fax.:0211 / 743307

The editorial staff will be pleased about your co-operation.

- FROM THE PRACTICE - FOR THE PRACTICE -



- **This service manual corresponds to the state of development of the machine at the time the manual was produced.**
- **Variations based on special customers request and special equipment are not included in this manual.**

Correct service and repair is extremely important for the safe operation of the machine.

The machine has been designed to suit your work, but it is still impossible to totally avoid any danger due to the size of the machine.

When working on the machine, always try to avoid any possible danger.

KEEP IN MIND

- **BE CAREFUL**
- **BE ALERT**
- **THINK ABOUT WHAT YOU ARE DOING**

Any PERSON doing any work in or around the machine must be familiar with the local **SAFETY INSTRUCTIONS** and with the specific **SAFETY INSTRUCTIONS REGARDING TO HIS OCCUPATION**

In this part we describe all functions; testing and adjustment procedures.

Of course for better understanding of the systems the hydraulic and electric circuit diagram is very helpful and a must for fault finding.

Whenever it is possible for the description the circuit diagram numbers / codes are used.

One who is not able to understand the circuit diagram or is not so familiar with the used symbols should study the hints for the circuit diagrams Section 10 and 11.

Following abbreviations are used:

PDG	=	Pump-Distributor-Gear
LBA	=	Loader-Bucket-Attachment
BHA	=	Back-Hoe-Attachment
MRV	=	Main-Relief Valve (Primary valve)
SRV	=	Service-line-Relief Valve (Secondary valve)
ACV	=	Anti-Cavitation Valve
EPM	=	Electronic-Power Module
ESR	=	Electronic-Signal Rectifier
ELL	=	Electronic-Load Limiter
EFM	=	Electronic-Fuel Measurement
DRE	=	Druck-Reduzierventil-Elektrisch (Pressure Reducing Valve Electrical)
EGR	=	Elektronische-Grenzlast-Regelung (Electronic Load Limit Regulation)
EBL	=	Electronic Bucket Leveling
ETM	=	Electronic Text and Monitoring System
CLS	=	Central Lubrication System
STC	=	Swing ring Teeth Central Lubrication System
PTO	=	Power Take Off
RPM	=	Revolutions Per Minute

All adjustments and pressure settings for the hydraulic circuits must be carried out at normal operating temperature!

For service intervals, oil levels and filling capacities see the "Service Literature", because this literature is always made for the specific machine !

- **Technical DATA (Leaflet)**
- **Assembly PROCEDURE (Brochure)**
- **Foreword.**

SECTION

- 1. Main assembly groups**
- 2. Drive**
- 3. Hydraulic oil tank**
- 4. Hydraulic oil cooling**
- 5. Controlling**
- 6. Components**
- 7. Main hydraulic pumps and pump regulation**
- 8. Operating hydraulic**
- 9. Hydraulic track tensioning system**
- 10. Access ladder hydraulic operated**
- 11. Central refilling system**
- 12. Hints for the hydraulic circuit diagram**
- 13. Hints for the electric circuit diagram**
- 14. Electronic Text Monitoring system**

APPENDIX



- **Each section includes a detailed table of contents.**

Table of Contents, Section 1

	Page
General lay out	2
Drive	3
Control blocks, swing gear	4
Under carriage, travel drive	5
Driver's cab	6

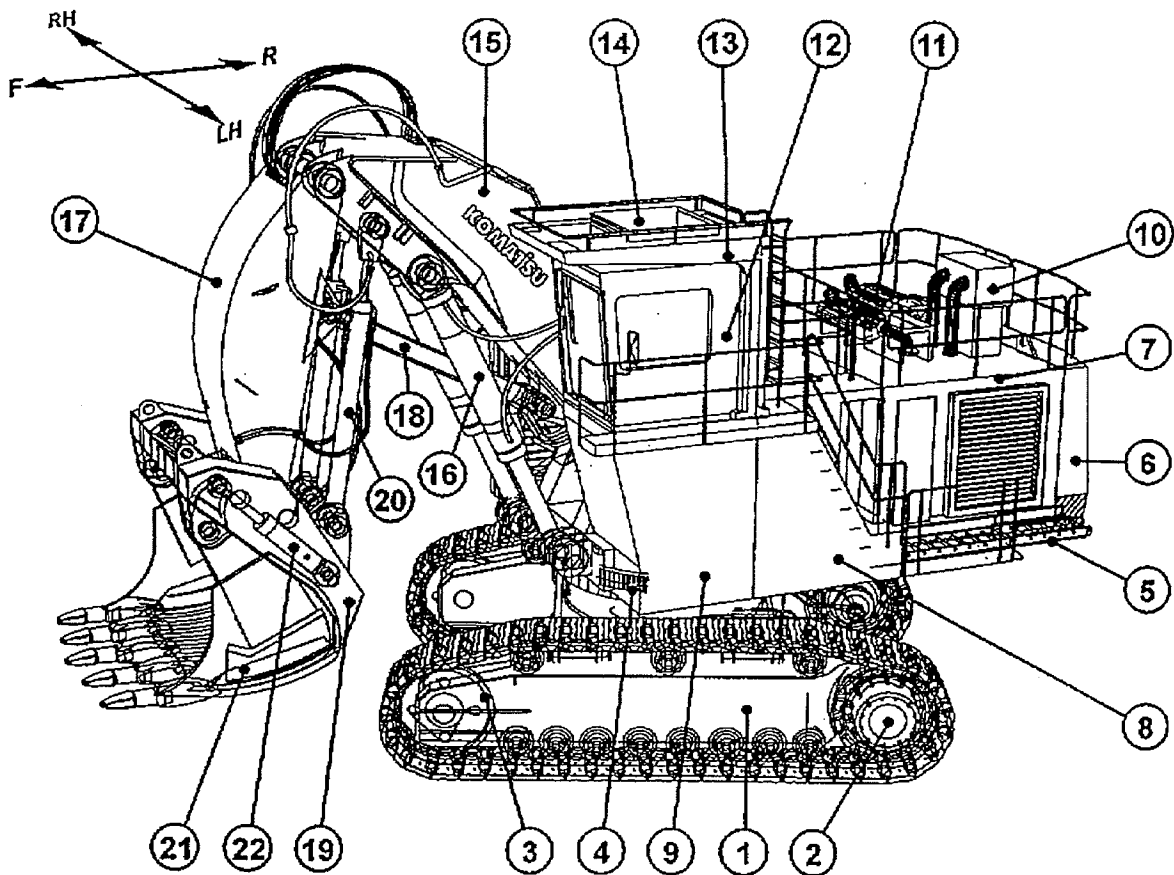
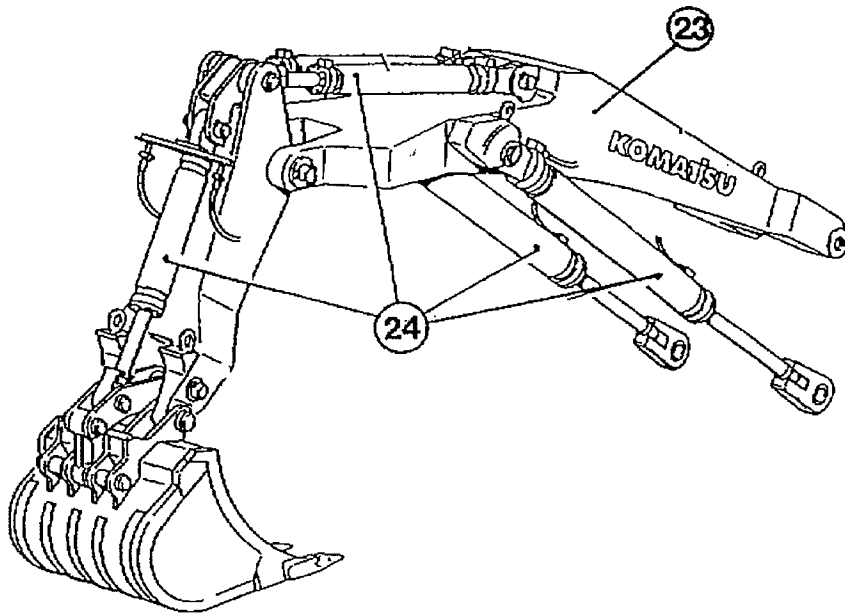

General Layout**Legend: Z 22175**

- (1) Undercarriage
- (2) Travel gear with sprocket
- (3) Guide wheel
- (4) Swing ring
- (5) Access Ladder, retractable
- (6) Counterweight
- (7) Machinery house
- (8) Fuel tank
- (9) Cab base
- (10) Air cleaner
- (11) Exhaust mufflers
- (12) Operators cabin
- (13) Falling Object Protective Structure (FOPS)
- (14) Air-conditioning for operators cabin
- (15) Boom, Bull-clam attachment
- (16) Boom cylinders
- (17) Stick, Bull-clam attachment
- (18) Stick cylinders
- (19) Bull-clam shovel
- (20) Bucket tilt cylinders
- (21) Bucket clam
- (22) Clam cylinders
- (23) Backhoe boom
- (24) Backhoe attachment cylinders

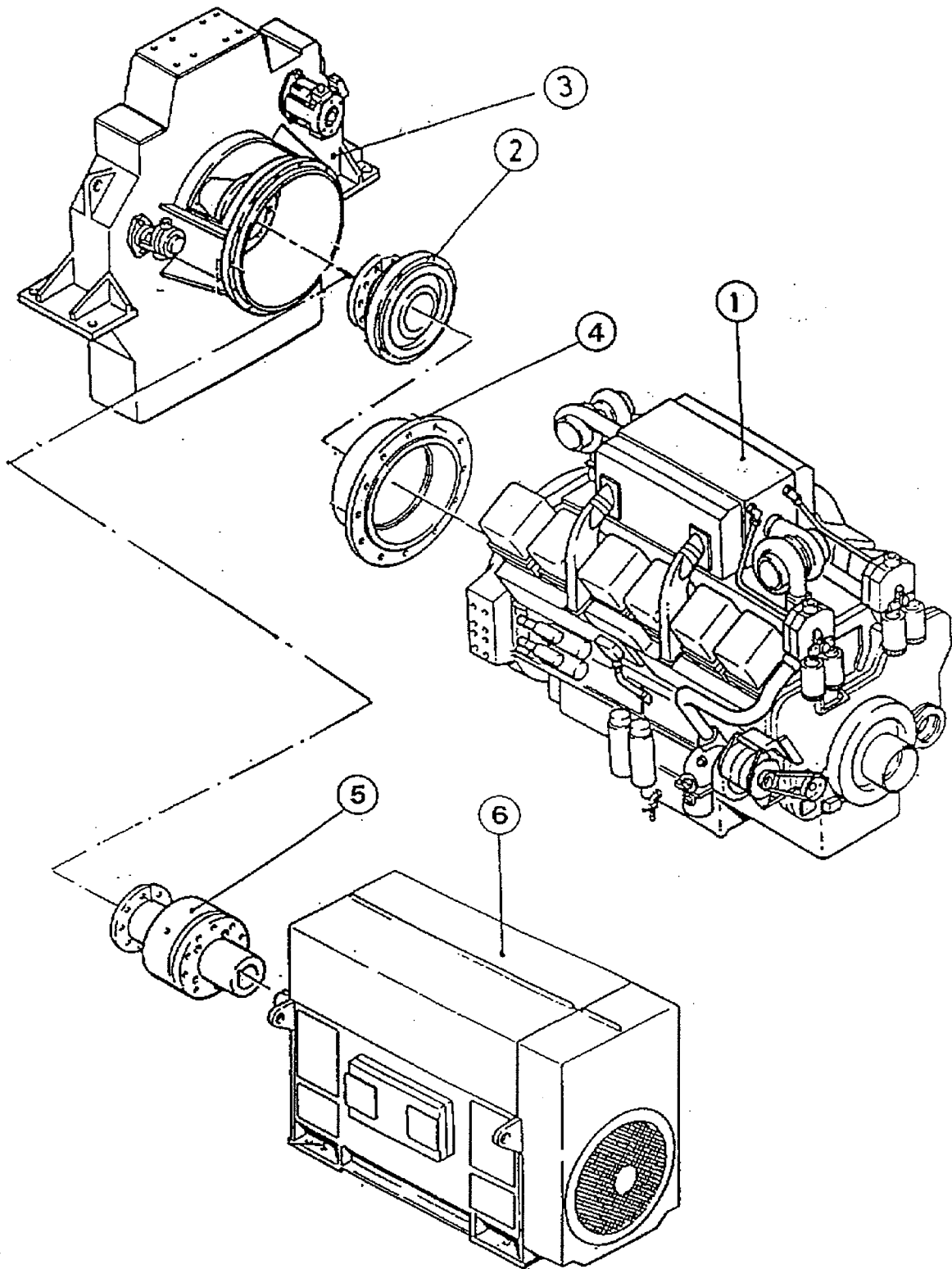

Drive**Legend: Z 22176**

- (1) Diesel engine
- (2) Elastic coupling, Diesel engine
- (3) PTO gear box
- (4) Adapter flange
- (5) Elastic coupling, Electrical motor
- (6) Electrical motor

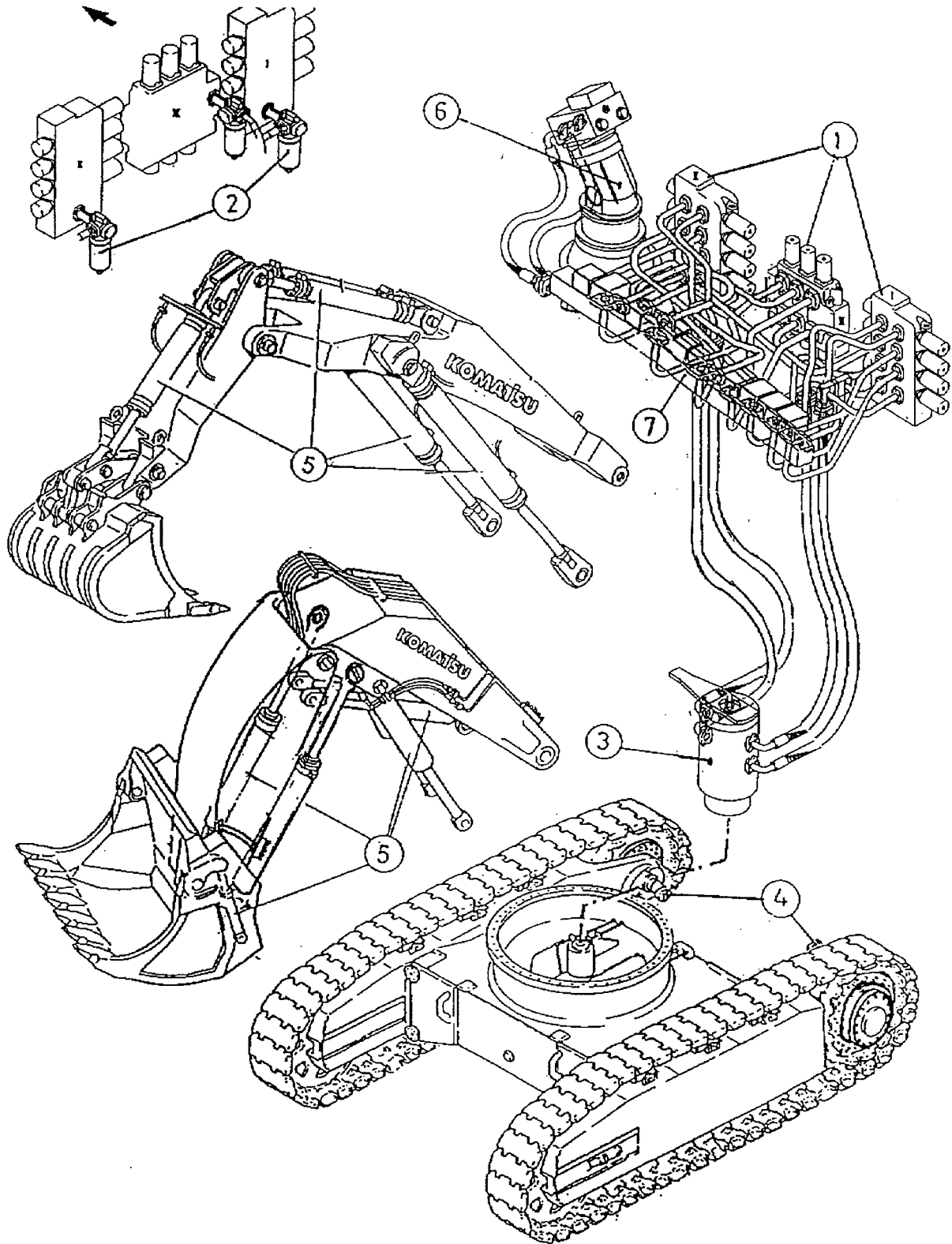

Control Blocks, Swing Gear

Legend: Z 22177

- (1) Main control blocks
- (2) High-pressure filter
- (3) Rotary joint
- (4) Travel motors
- (5) Attachment cylinders
- (6) Swing motor
- (7) Distributor manifold

Z 22178

KOMATSU
MINING GERMANY

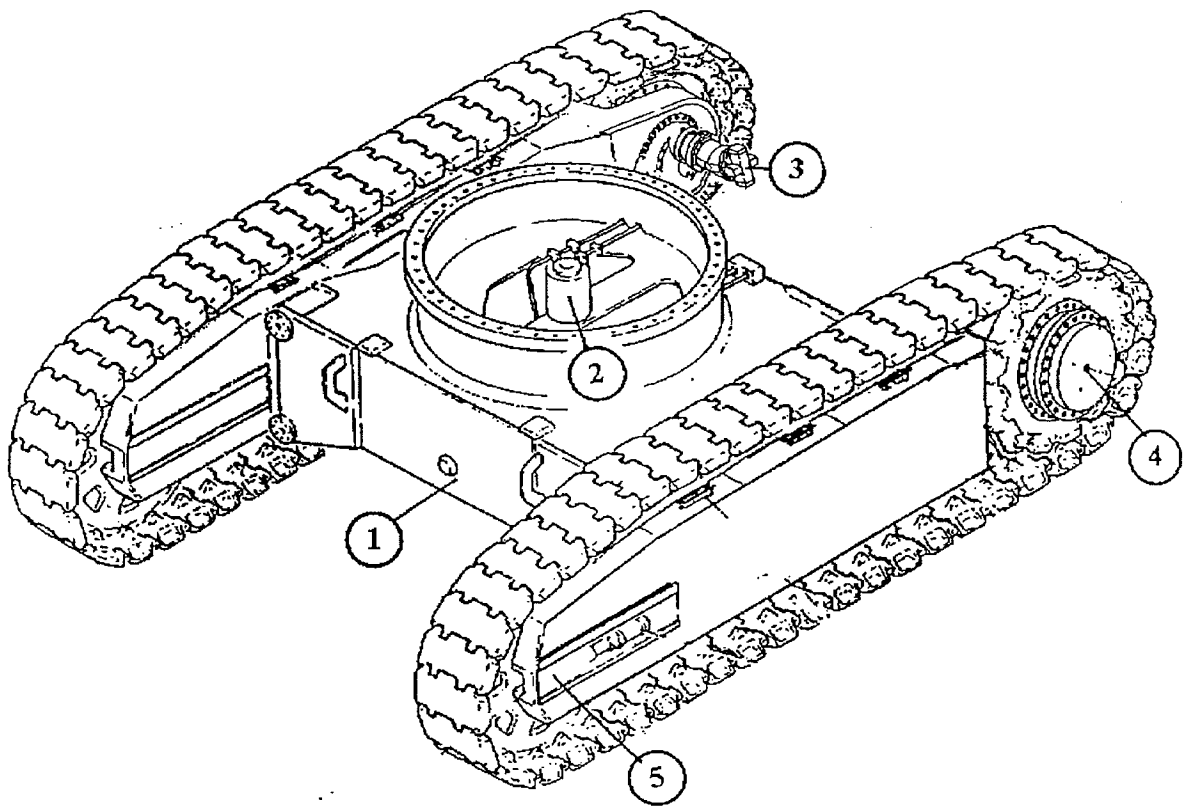

Undercarriage, Travel Drive**Legend: Z 22178**

- (1) Undercarriage
- (2) Rotary distributor
- (3) Travel motors
- (4) Final drive assy.
- (5) Idler wheel with hydraulic track tensioning cylinder.

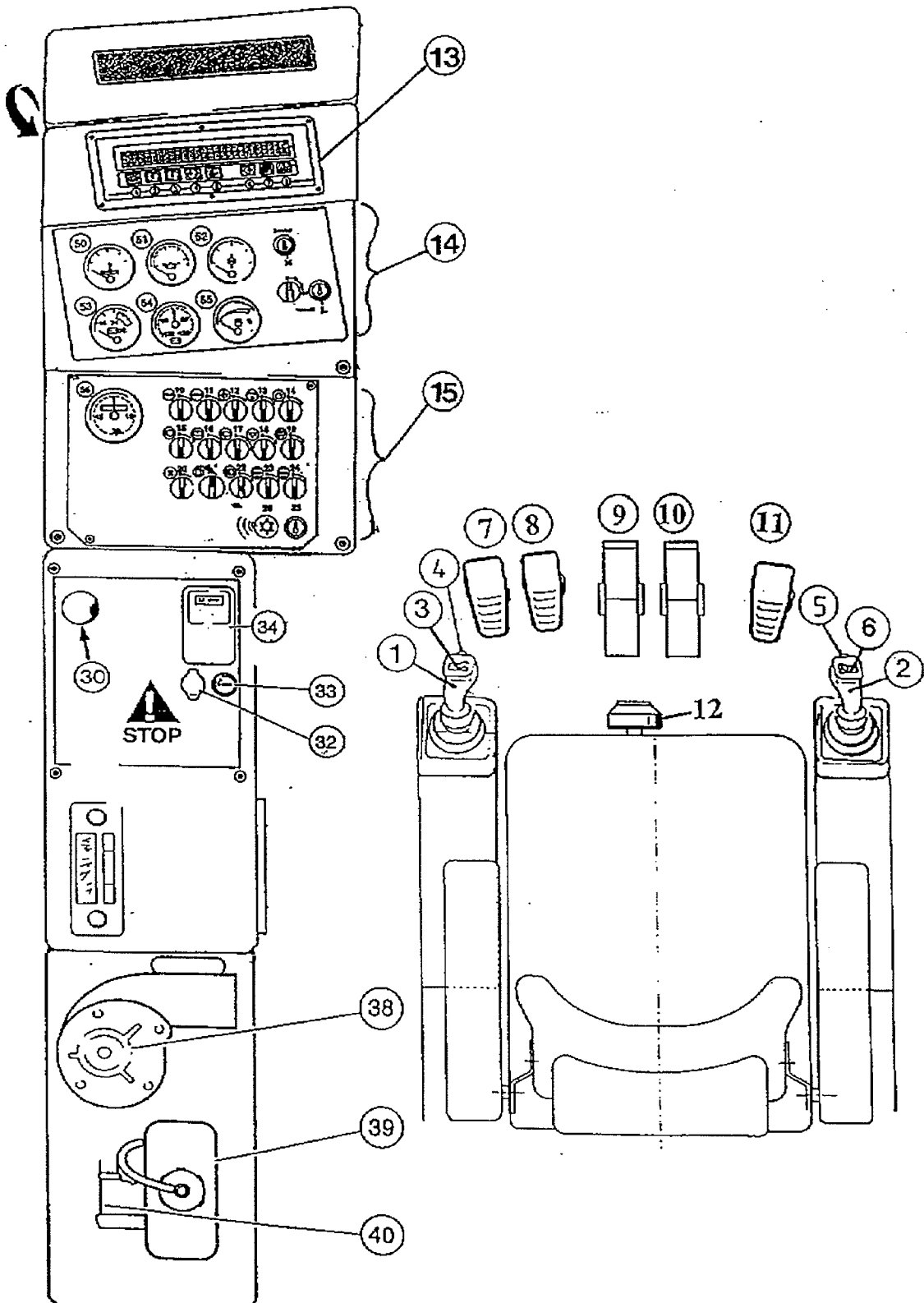

Driver's Cab**Legend: Z 22179**

- (1) L.H. Attachment control lever
- (2) R.H. Attachment control lever
- (3) High idle / Low idle switch
- (4) Truck counter button
- (5) Horn button
- (6) not used
- (7) Clam opening control pedal
- (8) Clam closing control pedal
- (9) L.H. Travel control pedal
- (10) R.H. Travel control pedal
- (11) Swing brake
- (12) Drivers seat
- (13) ETM - Electronic Text Display
- (14) Gauges
- (15) Switch board
- (30) Emergency stop button
- (32) 24 Volt Socket
- (33) Cigarette lighter
- (34) Ash dry
- (38) Pressurizing fan
- (39) Windshield washer container
- (40) Windshield washer pump

Table Of Content, Section 2

	Page
Prime drive assembly	2
Engine mounts	3
Fan drive assy.	4
Coupling	5
Air cleaner	6
Pump distributor gearbox	7
Pump spline lubrication	8
PTO- gear lubrication	9 + 10
Hydraulic pump location	11

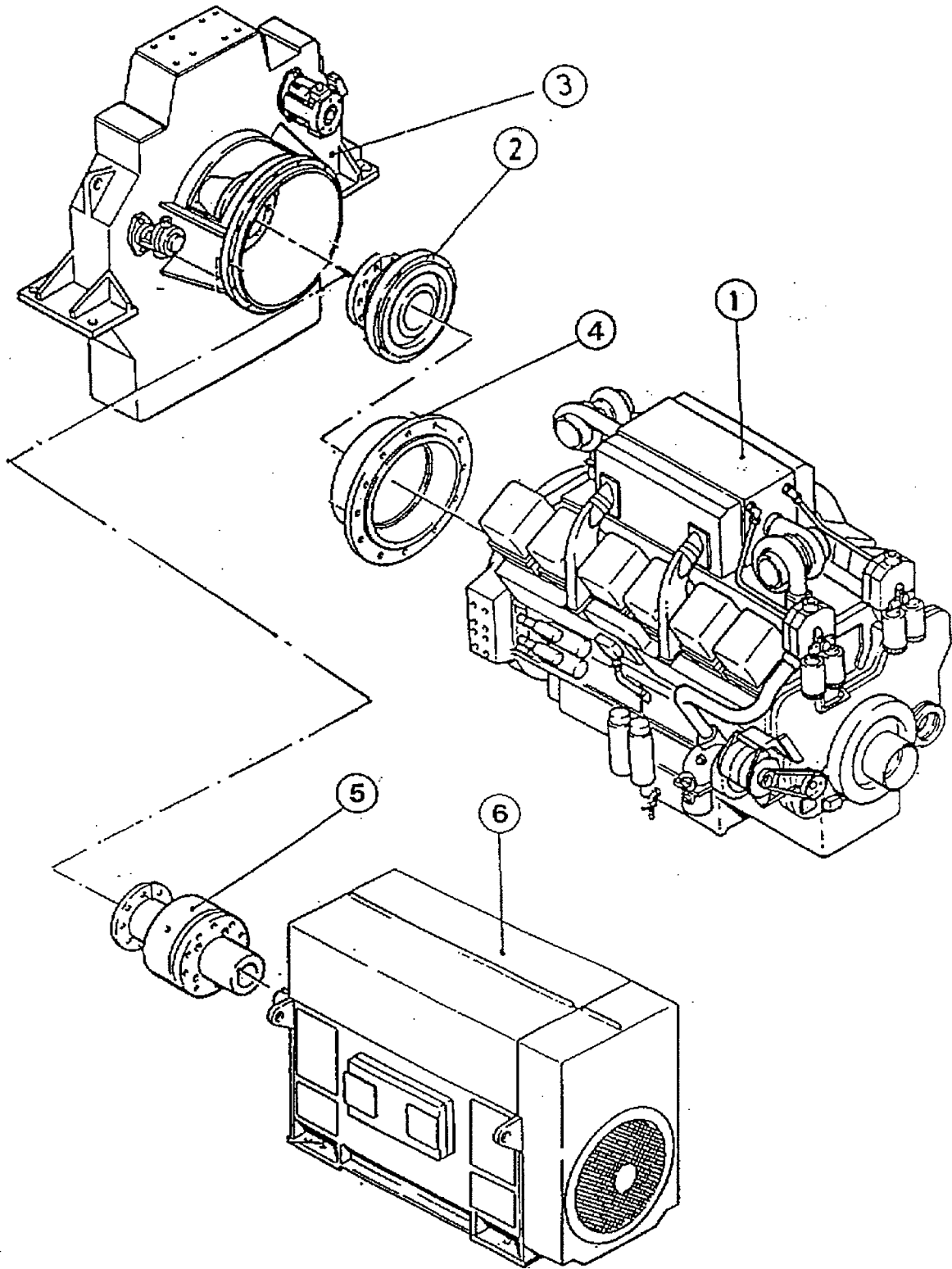

Prime Drive Assembly**General**

The PC 3000 is driven by a CUMMINS engine.

Legend: Z 22176

- (1) Engine
- (2) Torsion type coupling (diesel drive)
- (3) Pump distributor gear
- (4) Adapter flange
- (5) Torsion type coupling (electric drive)
- (6) Electric motor

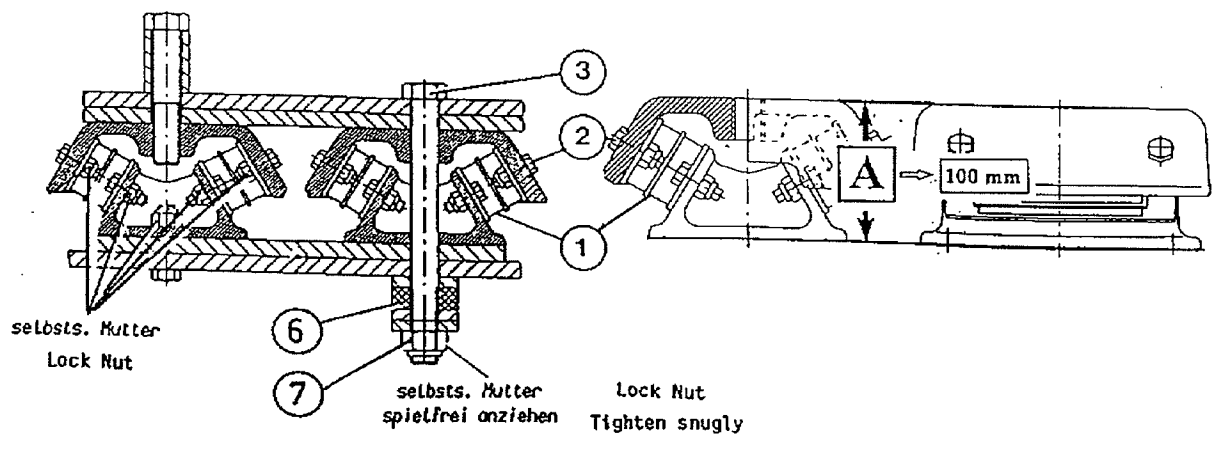
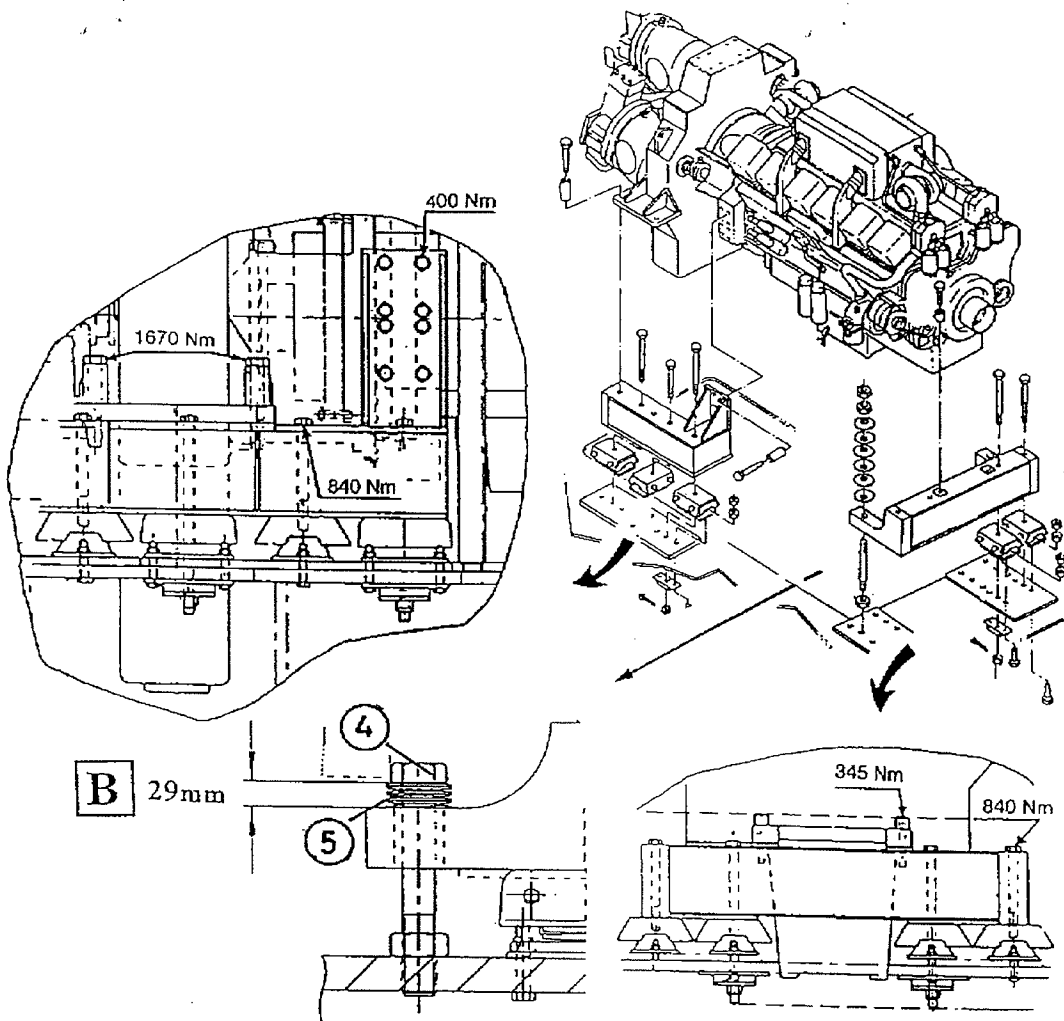

Engine Mounts

Z 22181

The flexible mounts are installed to take the vibrations and the torsional forces and they carry the total weight of the engine, the pump distributor gear with all hydraulic pumps.

For this reason all connections must be checked when above parts mounted to the engine.

As the life increases the engine mounts loose their stiffness (signs of fatigue) and the gap "A" decreases. ("A" = 100 mm see note below)



- **Because a fatigue limit is difficult to determine therefore all mounts must be checked regularly for no contacts are made between metal surfaces while engine under load.**

In the case of fatigue or damage of a metal rubber guide (1), **all** metal rubber guides and their fastening bolts (2) with nuts must be replaced.

Inspect also the metal-rubber-bar (6) for fatigue or damage and replace if necessary.

The bolt (3) must have **no** axial play.

If necessary re-tight the nut (7) until rubber squeeze slightly out of rubber bar (6).

Torque supports:



- **They are normally used only with CUMMINS engines.**

Check regularly the cup springs (5) of both supports for fatigue or damage and replace them if necessary. Turn the bolt(4) down until it pre-stress slightly the cup spring and secure with the check nut.

(Distance between torsional support and bolt head "B" = 29 mm)



- **The lock nuts can be re-used 3 to 4 times. Assumed the bolt thread is accurate cleaned before turning the nut on or off, otherwise the locking part of the nut will be damaged and the locking is not ensured.**

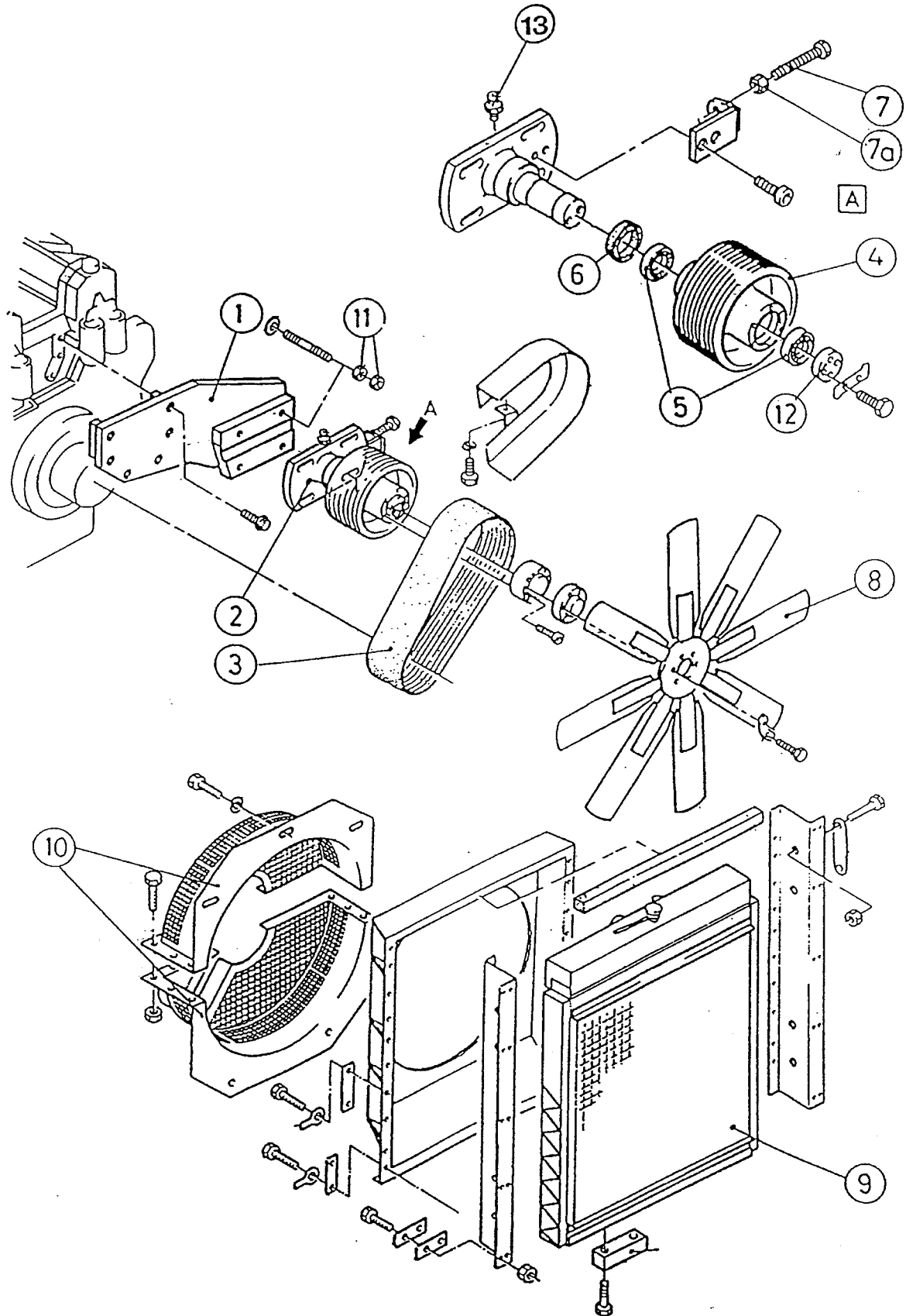

Fan Drive and Cooler Assy.**Legend: Z 22121**

- (1) Main bracket
- (2) Pulley bracket
- (3) Drive belt
- (4) Pulley
- (5) Taper roller bearing
- (6) Radial seal ring
- (7) Tensioning bolt
- (7a) Lock nut
- (8) Cooler fan
- (9) Radiator
- (10) Fan shroud
- (11) Lock nut
- (12) Retainer
- (13) Grease fitting

The fan is driven by the engine via a special drive belt (3).

The air is drawn through the radiator (9) by the fan.

The bearings are factory filled with grease and a grease nipple is provided. If due to overheating there is a loss of grease the pulley group must be re-lubricated by a hand operated grease gun. (refer to section 6.3, page 2 of the Maintenance Manual)

The drive belt tensioning is done by shifting bracket (2).

For this purpose, the nuts (11 and 7a) must be loosened. Now the bracket can be shifted by means of the bolt (7).

For more detailed information see Section 6.3, page 1 of the Maintenance Manual.



- **After a replacement of the bearings make sure that they are not pre-loaded.**
- **Between the retainer (12) and the bearing must be a gap of 0,05 mm.**

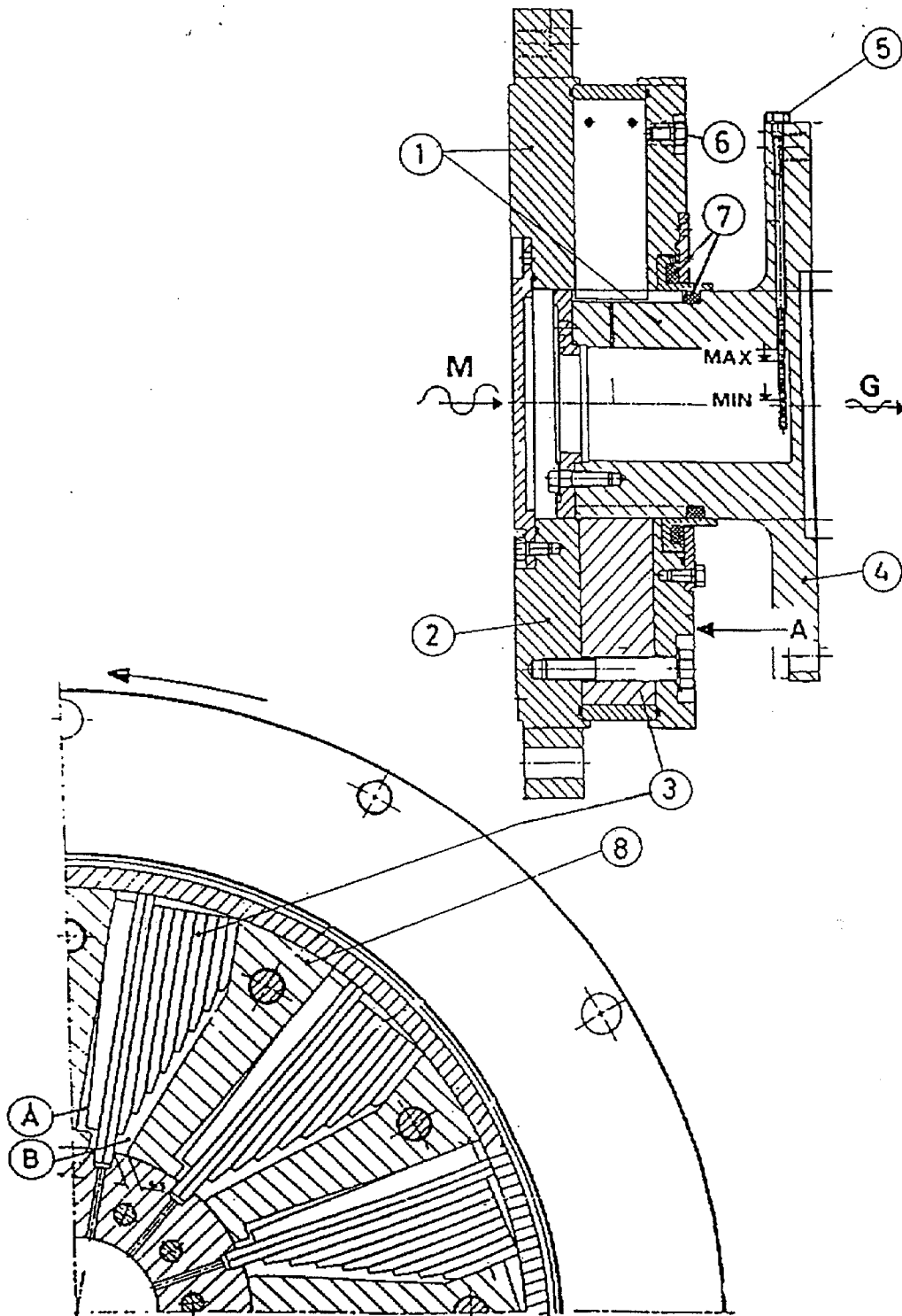



Download the full PDF manual instantly.

Our customer service e-mail:

aservicemanualpdf@yahoo.com