

SHOP

MANUAL

KOMATSU

PC27MRX-1 PC30MRX-1 PC35MRX-1 PC40MRX-1 PC45MRX-1

MACHINE MODEL	SERIAL NUMBER
PC27MRX-1	11574 and up
PC30MRX-1	10001 and up
PC35MRX-1	3930 and up
PC40MRX-1	1001 and up
PC45MRX-1	1001 and up

- This shop manual may contain attachments and optional equipment that are not available in your area. Please consult your local Komatsu distributor for those items you may require. Materials and specifications are subject to change without notice.
- PC27MRX-1 mount the 3D82AE-3 and PC30, 35MRX-1 mount the 3D84E-3 engine. For details of the engine, see the 68E-88E Series Engine Shop Manual.
- PC40MRX, PC45MRX-1 mount the 4D84E-3 and 4D88E-3 engine. For details of the engine, see the 68E-88E Series Engine Shop Manual.
- In some cases model name is written as PC27MR, PC30MR, PC35MR, PC40MR and PC45MR in the drawing. These names are same as PC27MRX, PC30MRX, PC35MRX, PC40MRX and PC45MRX.

CONTENTS

	No. of page
01 GENERAL	01-1
10 STRUCTURE AND FUNCTION	10-1
20 TESTING AND ADJUSTING	20-1
30 DISASSEMBLY AND ASSEMBLY	30-1
40 MAINTENANCE STANDARD	40-1
90 OTHERS	90-1

SAFETY

SAFETY NOTICE

IMPORTANT SAFETY NOTICE

Proper service and repair is extremely important for safe machine operation. The service and repair techniques recommended by Komatsu and described in this manual are both effective and safe. Some of these techniques require the use of tools specially designed by Komatsu for the specific purpose.

To prevent injury to workers, the symbol  is used to mark safety precautions in this manual. The cautions accompanying these symbols should always be followed carefully. If any dangerous situation arises or may possibly arise, first consider safety, and take the necessary actions to deal with the situation.

GENERAL PRECAUTIONS

Mistakes in operation are extremely dangerous. Read the Operation and Maintenance Manual carefully BEFORE operating the machine.

1. Before carrying out any greasing or repairs, read all the precautions given on the decals which are fixed to the machine.
2. When carrying out any operation, always wear safety shoes and helmet. Do not wear loose work clothes, or clothes with buttons missing.
 - Always wear safety glasses when hitting parts with a hammer.
 - Always wear safety glasses when grinding parts with a grinder, etc.
3. If welding repairs are needed, always have a trained, experienced welder carry out the work. When carrying out welding work, always wear welding gloves, apron, hand shield, cap and other clothes suited for welding work.
4. When carrying out any operation with two or more workers, always agree on the operating procedure before starting. Always inform your fellow workers before starting any step of the operation. Before starting work, hang UNDER REPAIR signs on the controls in the operator's compartment.
5. Keep all tools in good condition and learn the correct way to use them.

6. Decide a place in the repair workshop to keep tools and removed parts. Always keep the tools and parts in their correct places. Always keep the work area clean and make sure that there is no dirt or oil on the floor. Smoke only in the areas provided for smoking. Never smoke while working.

PREPARATIONS FOR WORK

7. Before adding oil or making any repairs, park the machine on hard, level ground, and block the wheels or tracks to prevent the machine from moving.
8. Before starting work, lower blade, ripper, bucket or any other work equipment to the ground. If this is not possible, insert the safety pin or use blocks to prevent the work equipment from falling. In addition, be sure to lock all the control levers and hang warning signs on them.
9. When disassembling or assembling, support the machine with blocks, jacks or stands before starting work.
10. Remove all mud and oil from the steps or other places used to get on and off the machine. Always use the handrails, ladders or steps when getting on or off the machine. Never jump on or off the machine. If it is impossible to use the handrails, ladders or steps, use a stand to provide safe footing.

PRECAUTIONS DURING WORK

11. When removing the oil filler cap, drain plug or hydraulic pressure measuring plugs, loosen them slowly to prevent the oil from spurting out. Before disconnecting or removing components of the oil, water or air circuits, first remove the pressure completely from the circuit.
12. The water and oil in the circuits are hot when the engine is stopped, so be careful not to get burned. Wait for the oil and water to cool before carrying out any work on the oil or water circuits.
13. Before starting work, remove the leads from the battery. Always remove the lead from the negative (-) terminal first.
14. When raising heavy components, use a hoist or crane. Check that the wire rope, chains and hooks are free from damage. Always use lifting equipment which has ample capacity. Install the lifting equipment at the correct places. Use a hoist or crane and operate slowly to prevent the component from hitting any other part. Do not work with any part still raised by the hoist or crane.
15. When removing covers which are under internal pressure or under pressure from a spring, always leave two bolts in position on opposite sides. Slowly release the pressure, then slowly loosen the bolts to remove.
16. When removing components, be careful not to break or damage the wiring. Damaged wiring may cause electrical fires.
17. When removing piping, stop the fuel or oil from spilling out. If any fuel or oil drips onto the floor, wipe it up immediately. Fuel or oil on the floor can cause you to slip, or can even start fires.
18. As a general rule, do not use gasoline to wash parts. In particular, use only the minimum of gasoline when washing electrical parts.
19. Be sure to assemble all parts again in their original places. Replace any damaged parts with new parts.
 - When installing hoses and wires, be sure that they will not be damaged by contact with other parts when the machine is being operated.
20. When installing high pressure hoses, make sure that they are not twisted. Damaged tubes are dangerous, so be extremely careful when installing tubes for high pressure circuits. Also, check that connecting parts are correctly installed.
21. When assembling or installing parts, always use the specified tightening torques. When installing protective parts such as guards, or parts which vibrate violently or rotate at high speed, be particularly careful to check that they are installed correctly.
22. When aligning two holes, never insert your fingers or hand. Be careful not to get your fingers caught in a hole.
23. When measuring hydraulic pressure, check that the measuring tool is correctly assembled before taking any measurements.
24. Take care when removing or installing the tracks of track-type machines. When removing the track, the track separates suddenly, so never let anyone stand at either end of the track.

FOREWORD

GENERAL

This shop manual has been prepared as an aid to improve the quality of repairs by giving the serviceman an accurate understanding of the product and by showing him the correct way to perform repairs and make judgments. Make sure you understand the contents of this manual and use it to full effect at every opportunity.

This shop manual mainly contains the necessary technical information for operations performed in a service workshop. For ease of understanding, the manual is divided into the following chapters; these chapters are further divided into the each main group of components.

STRUCTURE AND FUNCTION

This section explains the structure and function of each component. It serves not only to give an understanding of the structure, but also serves as reference material for troubleshooting.

In addition, this section may contain hydraulic circuit diagrams, electric circuit diagrams, and maintenance standards.

TESTING AND ADJUSTING

This section explains checks to be made before and after performing repairs, as well as adjustments to be made at completion of the checks and repairs.

Troubleshooting charts correlating "Problems" with "Causes" are also included in this section.

DISASSEMBLY AND ASSEMBLY

This section explains the procedures for removing, installing, disassembling and assembling each component, as well as precautions for them.

MAINTENANCE STANDARD

This section gives the judgment standards for inspection of disassembled parts.

The contents of this section may be described in STRUCTURE AND FUNCTION.

OTHERS

This section mainly gives hydraulic circuit diagrams and electric circuit diagrams.

In addition, this section may give the specifications of attachments and options together.

NOTICE

The specifications contained in this shop manual are subject to change at any time and without any advance notice. Use the specifications given in the book with the latest date.

HOW TO READ THE SHOP MANUAL

VOLUMES

Shop manuals are issued as a guide to carrying out repairs. They are divided as follows:

Chassis volume: Issued for every machine model

Engine volume: Issued for each engine series

Electrical volume: } Each issued as one
Attachments volume: } volume to cover all models

These various volumes are designed to avoid duplicating the same information. Therefore, to deal with all repairs for any model, it is necessary that chassis, engine, electrical and attachment volumes be available.

DISTRIBUTION AND UPDATING

Any additions, amendments or other changes will be sent to KOMATSU distributors. Get the most up-to-date information before you start any work.

FILING METHOD

1. See the page number on the bottom of the page. File the pages in correct order.
2. Following examples show how to read the page number.

Example 1 (Chassis volume):

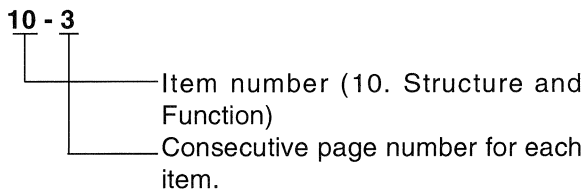

Example 2 (Engine volume):

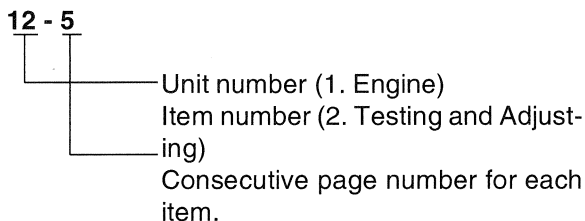

3. Additional pages: Additional pages are indicated by a hyphen (-) and number after the page number. File as in the example.

Example:

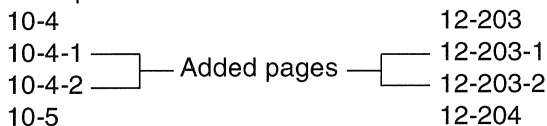

REVISED EDITION MARK

When a manual is revised, an edition mark (①②③....) is recorded on the bottom of the pages.

REVISIONS

Revised pages are shown in the LIST OF REVISED PAGES next to the CONTENTS page.

SYMBOLS

So that the shop manual can be of ample practical use, important safety and quality portions are marked with the following symbols.

Symbol	Item	Remarks
	Safety	Special safety precautions are necessary when performing the work.
	Caution	Special technical precautions or other precautions for preserving standards are necessary when performing the work.
	Weight	Weight of parts of systems. Caution necessary when selecting hoisting wire, or when working posture is important, etc.
	Tightening torque	Places that require special attention for the tightening torque during assembly.
	Coat	Places to be coated with adhesives and lubricants, etc.
	Oil, water	Places where oil, water or fuel must be added, and the capacity.
	Drain	Places where oil or water must be drained, and quantity to be drained.

REMOVAL OF STARTING MOTOR ASSEMBLY

PC27MRX, PC30MRX

- ⚠ Stop the machine on the horizontal ground, then lower the work equipment completely to the ground and stop the engine.
- ⚠ Disconnect the cable from the negative (-) terminal of the battery.

1. Remove seat bracket and right and left PPC valve assembly. For details, see REMOVAL OF SEAT BRACKET, R.H. AND L.H. PPC VALVE ASSEMBLY.
2. Disconnect wiring connector (1) (T4).
3. Remove the boots, then disconnect 2 wires (2).
4. Remove starting motor assembly (3).

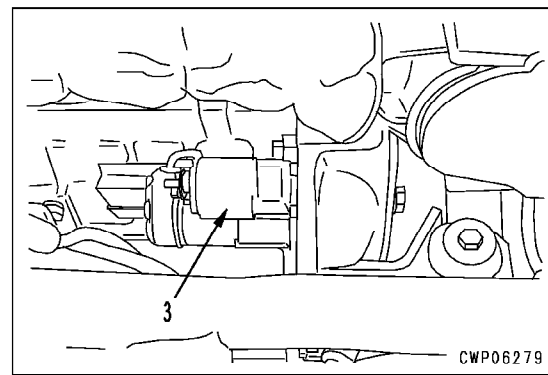
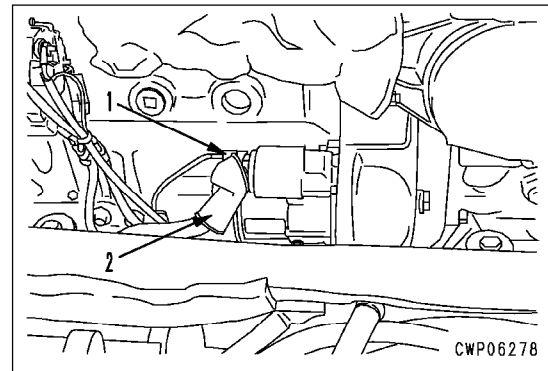

INSTALLATION OF STARTING MOTOR ASSEMBLY

PC27MRX, PC30MRX

- Carry out installation in the reverse order to removal.

REMOVAL OF STARTING MOTOR ASSEMBLY

PC35MRX, PC40MRX, PC45MRX

⚠ Disconnect the cable from the negative (-) terminal of the battery.

1. Remove air-conditioner unit assembly.
 - ★ For operator cabin specification machine only.
2. Remove inspection cover (1) at under of operator's seat.
3. Disconnect wiring connector (2).
 - ★ Wiring connector (T4) : PC35MRX
 - ★ Wiring connector (M10) : PC40MRX, PC45MRX
4. Remove the boots and disconnect 2 wire (3).

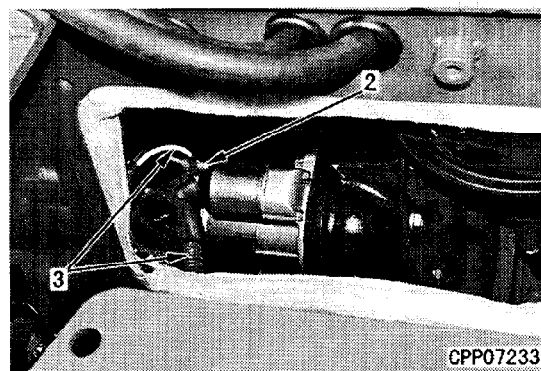
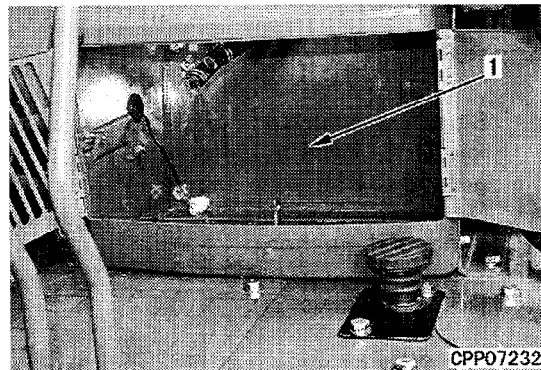

5. Remove starting motor assembly (4).

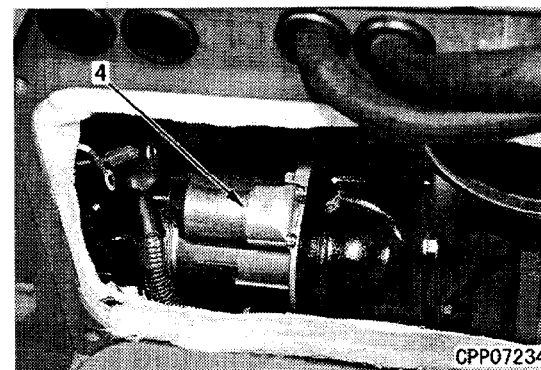

INSTALLATION OF STARTING MOTOR ASSEMBLY

PC35MRX, PC40MRX, PC45MRX

- Carry out installation in the reverse order to removal.

REMOVAL OF ALTERNATOR ASSEMBLY

PC27MRX, PC30MRX

- ⚠ Stop the machine on the horizontal ground, then lower the work equipment completely to the ground and stop the engine.
- ⚠ Disconnect the cable from the negative (-) terminal of the battery.

1. Remove the cover (1).
2. Disconnect connector (2) (E1) and (3) (E2).
3. Disconnect water temperature sensor connector (4) (E7).
4. Remove adjustment bolt (5).
5. Loosen mounting bolt, and remove alternator belt (7). ※ 1
6. Remove mounting bolt (6) and remove the alternator assembly (8).

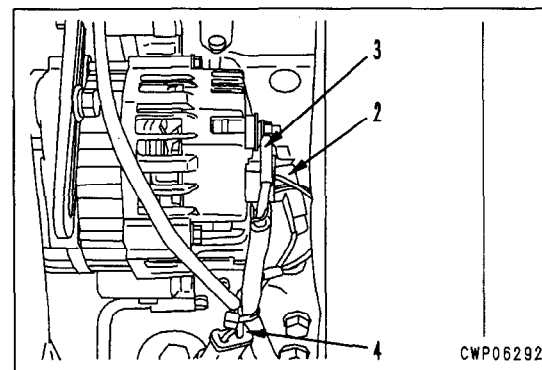
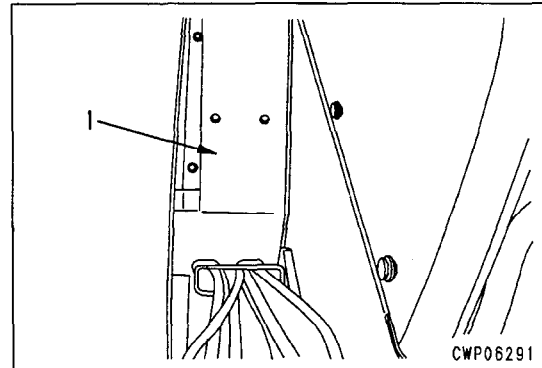

INSTALLATION OF ALTERNATOR ASSEMBLY

PC27MRX, PC30MRX

- Carry out installation in the reverse order to removal.

※ 1

- ★ Adjust the alternator belt. For details, see TESTING AND ADJUSTING, Testing and adjusting alternator belt tension.

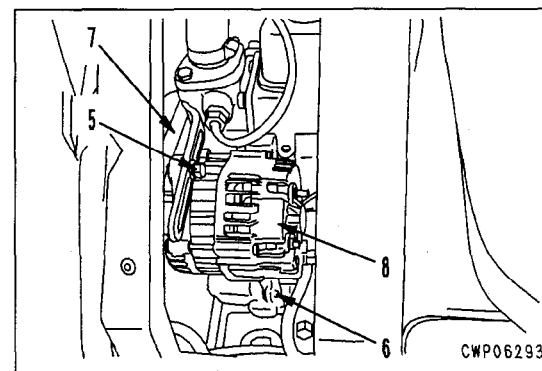

REMOVAL OF ALTERNATOR ASSEMBLY

PC35MRX

⚠ Disconnect the cable from the negative (-) terminal of the battery.

1. Remove the right lever stand assembly (1) with mounting bracket.
2. Disconnect wiring connector (2) (E1,E2).
3. Disconnect wire (3).
4. Loosen mounting bolt and adjustment bolt (4).
5. Remove adjustment bracket (5), then remove fan belt (6) from pulley. ※ 1
 - ★ It is not able to remove the fan belt from pulley, after remove adjustment bracket.
 - ★ There are spacers fitted to the adjustment bolts so be careful not to drop them.
6. Remove the alternator assembly (7).
 - ★ There are spacers fitted to the mounting bolts so be careful not to drop them.

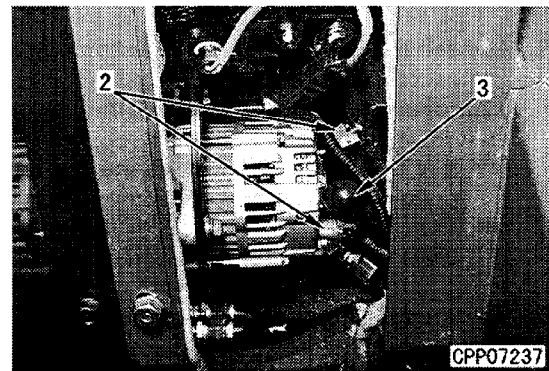
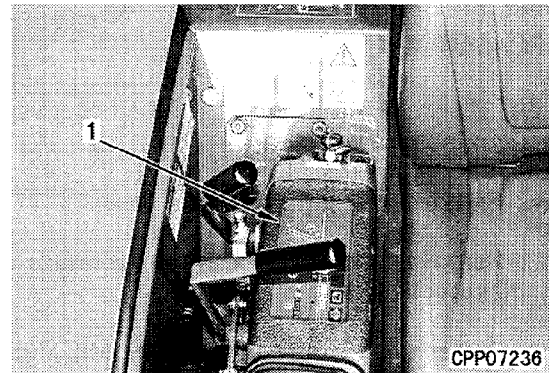

INSTALLATION OF ALTERNATOR ASSEMBLY

PC35MRX

- Carry out installation in the reverse order to removal.

※ 1

- ★ Adjust the alternator belt. For details, see TESTING AND ADJUSTING, Testing and adjusting alternator belt tension.

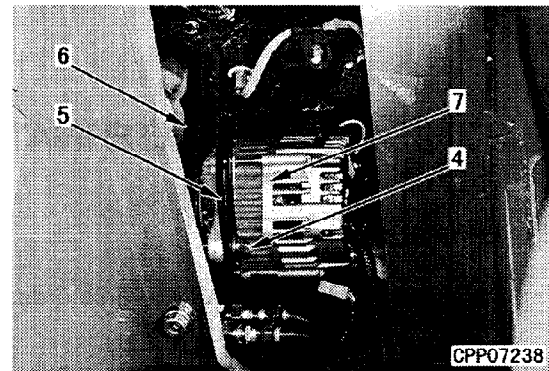

REMOVAL OF ALTERNATOR ASSEMBLY

PC40MRX, PC45MRX

⚠ Disconnect the cable from the negative (-) terminal of the battery.

1. Remove the right side upper cover.
2. Remove the cover (1) between operator's cab and hydraulic tank.
3. Disconnect wiring connector (2) (M8, M9).
4. Disconnect wire (3).
5. Loosen mounting bolt and adjustment bolt (4).
6. Remove adjustment bracket (5), then remove fan belt (6) from pulley. ※ 1
 - ★ It is not enable to remove the fan belt from pulley, after remove adjustment bracket.
 - ★ There are spacers fitted to the adjustment bolts so be careful not to drop them.
7. Remove the alternator assembly.
 - ★ There are spacers fitted to the mounting bolts so be careful not to drop them.

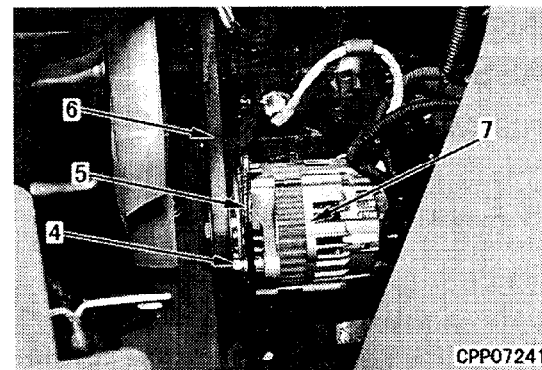
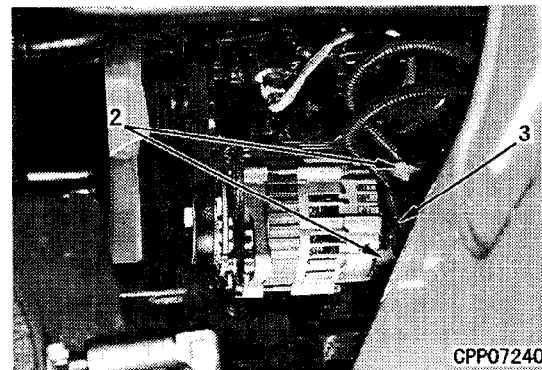
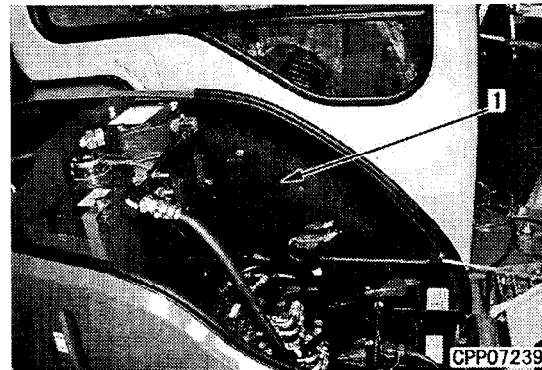

INSTALLATION OF ALTERNATOR ASSEMBLY

PC45MRX, PC45MRX

- Carry out installation in the reverse order to removal.

※ 1

- ★ Adjust the alternator belt. For details, see TESTING AND ADJUSTING, Testing and adjusting alternator belt tension.



Download the full PDF manual instantly.

Our customer service e-mail:

aservicemanualpdf@yahoo.com