

4475, 5575, 6675 & 7775 Skid Steer Loaders

Serial No. (010001 -)

TECHNICAL MANUAL

**John Deere
Lawn & Grounds Care Division
TM1553 (April 95)**

Safety



Specifications and Information



Engine (Diesel)



Electrical



Power Train



Power Train (Hydrostatic)



Steering



Brakes



Hydraulics



Backhoe



Miscellaneous





HANDLE FLUIDS SAFELY-AVOID FIRES

- BE PREPARED FOR EMERGENCIES

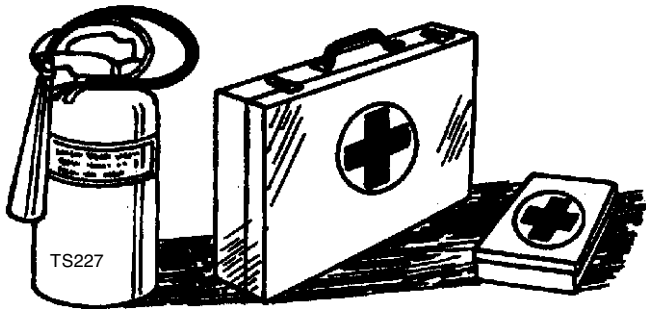

When you work around fuel, do not smoke or work near heaters or other fire hazards.

Store flammable fluids away from fire hazards. Do not incinerate or puncture pressurized containers.

Make sure machine is clean of trash, grease, and debris.

Do not store oily rags; they can ignite and burn spontaneously.

Be prepared if a fire starts.

Keep a first aid kit and fire extinguisher handy.

Keep emergency numbers for doctors, ambulance service, hospital, and fire department near your telephone.

HANDLE CHEMICAL PRODUCTS SAFELY

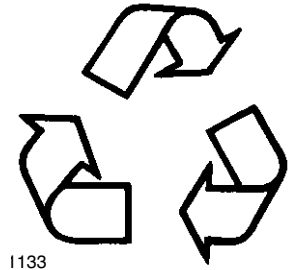

Direct exposure to hazardous chemicals can cause serious injury. Potentially hazardous chemicals used with John Deere equipment include such items as lubricants, coolants, paints, and adhesives.

A Material Safety Data Sheet (MSDS) provides specific details on chemical products: physical and health hazards, safety procedures, and emergency response techniques. Check the MSDS before you start any job using a hazardous chemical. That way you will know exactly what the risks are and how to do the job safely. Then follow procedures and recommended equipment.

- DISPOSE OF WASTE PROPERLY

Improperly disposing of waste can threaten the environment and ecology. Potentially harmful waste used with John Deere equipment include such items as oil, fuel, coolant, brake fluid, filters, and batteries. Use leakproof containers when draining fluids. Do not use food or beverage containers that may mislead someone into drinking from them. Do not pour waste onto the ground, down a drain, or into any water source. Inquire on the proper way to recycle or dispose of waste from your local environmental or recycling center, or from your John Deere dealer.

USE CARE AROUND HIGH-PRESSURE FLUID LINES

• AVOID HIGH-PRESSURE FLUIDS

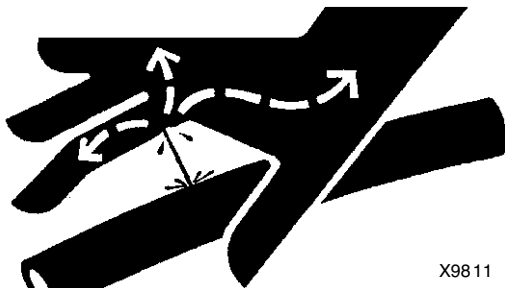

X9811

Escaping fluid under pressure can penetrate the skin causing serious injury.

Avoid the hazard by relieving pressure before disconnecting hydraulic or other lines. Tighten all connections before applying pressure.

Search for leaks with a piece of cardboard. Protect hands and body from high pressure fluids.

If an accident occurs, see a doctor immediately. Any fluid injected into the skin must be surgically removed within a few hours or gangrene may result. Doctors unfamiliar with this type of injury should reference a knowledgeable medical source. Such information is available from Deere & Company Medical Department in Moline, Illinois, U.S.A.

• AVOID HEATING NEAR PRESSURIZED FLUID LINES



TS953

Flammable spray can be generated by heating near pressurized fluid lines, resulting in severe burns to yourself and bystanders. Do not heat by welding, soldering, or using a torch near pressurized fluid lines or other flammable materials. Pressurized lines can be accidentally cut when heat goes beyond the immediate flame area.

USE CARE IN HANDLING AND SERVICING BATTERIES

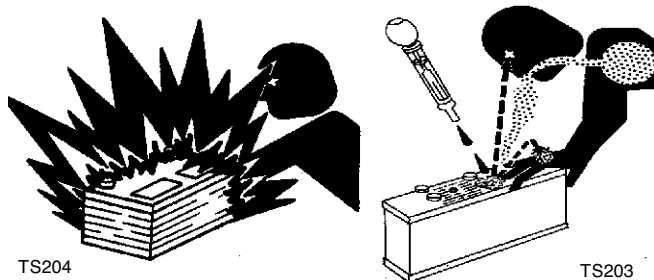

TS204

TS203

• PREVENT BATTERY EXPLOSIONS

- Keep sparks, lighted matches, and open flame away from the top of battery. Battery gas can explode.
- Never check battery charge by placing a metal object across the posts. Use a volt-meter or hydrometer.
- Do not charge a frozen battery; it may explode. Warm battery to 16°C (60°F).

• PREVENT ACID BURNS

- Sulfuric acid in battery electrolyte is poisonous. It is strong enough to burn skin, eat holes in clothing, and cause blindness if splashed into eyes.

• Avoid acid burns by:

1. Filling batteries in a well-ventilated area.
2. Wearing eye protection and rubber gloves.
3. Avoiding breathing fumes when electrolyte is added.
4. Avoiding spilling or dripping electrolyte.
5. Use proper jump start procedure.

• If you spill acid on yourself:

1. Flush your skin with water.
2. Apply baking soda or lime to help neutralize the acid.
3. Flush your eyes with water for 10_15 minutes.
4. Get medical attention immediately.

• If acid is swallowed:

1. Drink large amounts of water or milk.
2. Then drink milk of magnesia, beaten eggs, or vegetable oil.
3. Get medical attention immediately.



USE SAFE SERVICE PROCEDURES

• WEAR PROTECTIVE CLOTHING

Wear close fitting clothing and safety equipment appropriate to the job.

Prolonged exposure to loud noise can cause impairment or loss of hearing. Wear a suitable hearing protective device such as earmuffs or earplugs to protect against objectionable or uncomfortable loud noises.

Operating equipment safely requires the full attention of the operator. Do not wear radio or music headphones while operating machine.

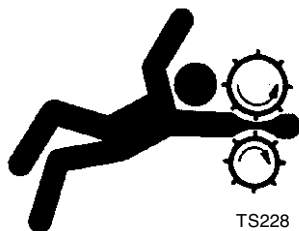
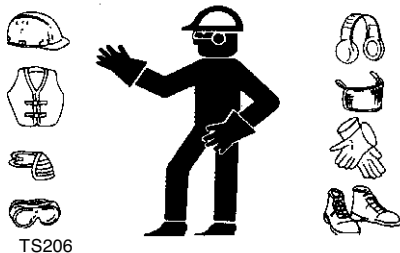

• SERVICE MACHINES SAFELY

Tie long hair behind your head. Do not wear a necktie, scarf, loose clothing, or necklace when you work near machine tools or moving parts. If these items were to get caught, severe injury could result.

Remove rings and other jewelry to prevent electrical shorts and entanglement in moving parts.

• USE PROPER TOOLS

Use tools appropriate to the work. Makeshift tools and procedures can create safety hazards. Use power tools only to loosen threaded parts and fasteners. For loosening and tightening hardware, use the correct size tools. **DO NOT** use U.S. measurement tools on metric fasteners. Avoid bodily injury caused by slipping wrenches. Use only service parts meeting John Deere specifications.

• PARK MACHINE SAFELY

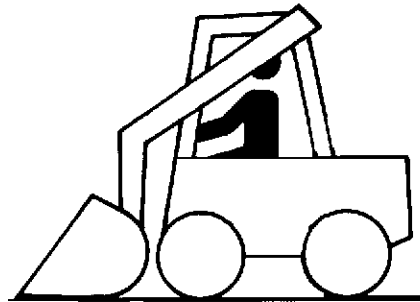

• Before working on the machine:

1. Lower all equipment to the ground.
2. Stop the engine and remove the key.
3. Disconnect the battery ground strap.
4. Hang a "DO NOT OPERATE" tag in operator station.

• SUPPORT MACHINE PROPERLY AND USE PROPER LIFTING EQUIPMENT

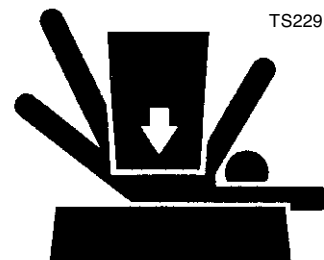

If you must work on a lifted machine or attachment, securely support the machine or attachment.

Do not support the machine on cinder blocks, hollow tiles, or props that may crumble under continuous load. Do not work under a machine that is supported solely by a jack. Follow recommended procedures in this manual.

Lifting heavy components incorrectly can cause severe injury or machine damage. Follow recommended procedure for removal and installation of components in the manual.

• WORK IN CLEAN AREA

• Before starting a job

1. Clean work area and machine:
2. Make sure you have all necessary tools to do your job.
3. Have the right parts on hand.
4. Read all instructions thoroughly; do not attempt shortcuts.

• ILLUMINATE WORK AREA SAFELY

Illuminate your work area adequately but safely. Use a portable safety light for working inside or under the machine. Make sure the bulb is enclosed by a wire cage. The hot filament of an accidentally broken bulb can ignite spilled fuel or oil.

• WORK IN VENTILATED AREA

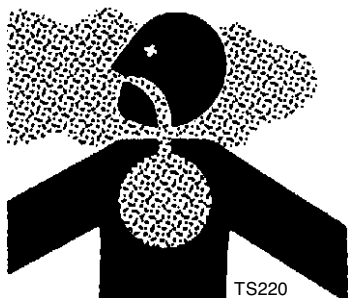

Engine exhaust fumes can cause sickness or death. If it is necessary to run an engine in an enclosed area, remove the exhaust fumes from the area with an exhaust pipe extension.

If you do not have an exhaust pipe extension, open the doors and get outside air into the area.

• REMOVE PAINT BEFORE WELDING OR HEATING

Avoid potentially toxic fumes and dust. Hazardous fumes can be generated when paint is heated by welding, soldering, or using a torch. Do all work outside or in a well ventilated area. Dispose of paint and solvent properly. Remove paint before welding or heating: If you sand or grind paint, avoid breathing the dust. Wear an approved respirator. If you use solvent or paint stripper, remove stripper with soap and water before welding. Remove solvent or paint stripper containers and other flammable material from area. Allow fumes to disperse at least 15 minutes before welding or heating.

• AVOID HARMFUL ASBESTOS DUST

:Avoid breathing dust that may be generated when handling components containing asbestos fibers. Inhaled asbestos fibers may cause lung cancer.

Components in products that may contain asbestos fibers are brake pads, brake band and lining assemblies, clutch plates, and some gaskets. The asbestos used in these components is usually found in a resin or sealed in some way. Normal handling is not hazardous as long as airborne dust containing asbestos is not generated.

Avoid creating dust. Never use compressed air for cleaning. Avoid brushing or grinding material containing asbestos. When servicing, wear an approved respirator. A special vacuum cleaner is recommended to clean asbestos. If not available, apply a mist of oil or water on the material containing asbestos. Keep bystanders away from the area.



• SERVICE TIRES SAFELY



Explosive separation of a tire and rim parts can cause serious injury or death.

Do not attempt to mount a tire unless you have the proper equipment and experience to perform the job. Always maintain the correct tire pressure. Do not inflate the tires above the recommended pressure. Never weld or heat a wheel and tire assembly. The heat can cause an increase in air pressure resulting in a tire explosion. Welding can structurally weaken or deform the wheel.

When inflating tires, use a clip-on chuck and extension hose long enough to allow you to stand to one side and NOT in front of or over the tire assembly. Use a safety cage if available.

- **Check wheels for low pressure, cuts, bubbles, damaged rims or missing lug bolts and nuts.**



REPLACE SAFETY SIGNS

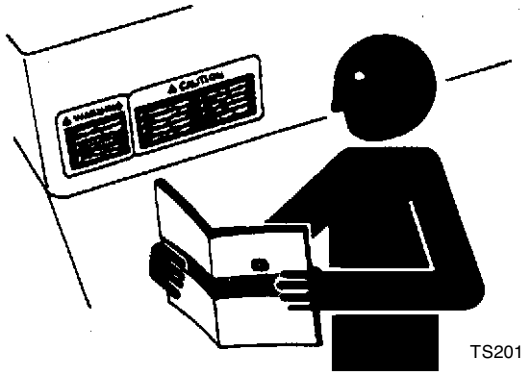

TS201

Replace missing or damaged safety signs. See the machine operator's manual for correct safety sign placement.

LIVE WITH SAFETY

TS231



Before returning machine to customer, make sure machine is functioning properly, especially the safety systems. Install all guards and shields.

CONTENTS

Page



SPECIFICATIONS & INFORMATION

GENERAL VEHICLE SPECIFICATIONS	2
UNIFIED INCH TORQUE VALUES	7
METRIC TORQUE VALUES	8
DIESEL FUEL SPECIFICATIONS	9
DIESEL FUEL STORAGE	9
LUBRICANT SPECIFICATIONS	10
ENGINE OIL	10
GREASE	10
TRANSMISSION AND HYDRAULIC OIL	11
CHAIN CASE OIL	11
GEARBOX OIL	11
ALTERNATIVE LUBRICANTS	11
SYNTHETIC LUBRICANTS	11
OIL FILTERS	11
LUBRICANT STORAGE	11
ENGINE COOLANT	12
SERIAL NUMBER LOCATION	12
SKID STEER LOADER PRODUCT IDENTIFICATION NUMBER	12
ENGINE SERIAL NUMBER	12

GENERAL VEHICLE SPECIFICATIONS



	4475	5575
ENGINE^a		
Make	John Deere Series 220	John Deere Series 220
Model	3015D001	3017D001
Type	Diesel	Diesel
Cylinders	3	3
Bore	84 mm (3.31 in.)	88 mm (3.46 in.)
Stroke	90 mm (3.54 in.)	90 mm (3.54 in.)
Displacement	1.5 L (91.3 cu. in.)	1.642 L (100.1 cu. in.)
Net horsepower	23 kW (31 hp) @ 3000 rpm	27.3 kW (36.6 hp) @ 3000 rpm
RPM, slow (no load)	900-1000	900-1000
RPM, fast (no load)	3125-3175	3125-3175
Lubrication	Full pressure	Full pressure
Crankcase capacity (with filter)	7.3 L (7.7 qt.)	7.3 L (7.7 qts.)
Cooling system	Liquid	Liquid
Coolant capacity radiator and block	10.3 L (10.8 qt.)	10.3 L (10.8 qt.)
Air filter type	Dry paper with primary and secondary elements	Dry paper with primary and secondary elements
ELECTRICAL		
Type of starter	Solenoid shift	Solenoid Shift
Battery voltage	12 Vdc	12 Vdc
Battery reserve capacity at 27°C (80° F)	160 minutes	160 minutes
Battery cold cranking amps at -18°C (0°F)	625	625
Charging system	40 amp alternator	40 amp alternator
FUEL SYSTEM		
Fuel	Diesel #1 or #2	Diesel #1 or #2
Capacity	37.8 L (10 gal)	37.8 L (10 gal)
Fuel delivery	Inline direct injection	Inline direct injection

	4475	5575
Fuel shut-off	Fuel shutoff solenoid	Fuel shutoff solenoid
POWER TRAIN		
Type	Hydrostatic	Hydrostatic
Charge pump	Gear	Gear
Hydrostatic pump	Variable displacement axial piston	Variable displacement axial piston
Hydrostatic pump relief pressure	23443-26201 kPa (3400-3800 psi)	23443-26201 kPa (3400-3800 psi)
Hydrostatic motor	Fixed displacement axial piston	Fixed displacement axial piston
Chain case capacity (each side)	5.7 L (1.5 gal.)	5.7 L (1.5 gal.)
Parking Brake	Dry disk on hydrostatic motor shaft	Dry disk on hydrostatic motor shaft
STEERING		
Type	Hydrostatic left and right drive motor s	Hydrostatic left and right drive motor s
PERFORMANCE		
SAE operating load	617 kg (1360 lb.)	640 kg (1410 lb.)
Hydraulic lift capacity	658 kg (1450 lb.)	658 kg. (1450 lb.)
Ground speed	0 - 10.5 km/h (0 - 6.5 mph)	0 - 10.5 km/h (0 - 6.5 mph)
Operating weight	1979 kg (4360 lb.)	2020 kg. (4450 lb.)
HYDRAULICS		
Main system relief pressure	17927 kPa (2600 psi)	17927 kPa (2600 psi)
Circuit relief pressure	18961 kPa (2750 psi)	18961 kPa (2750 psi)
Charge relief pressure	758 kPa (110 psi)	758 kPa (110 psi)
Charge pump flow	42 L/min. (11 gmp)	42 L/min. (11 gmp)
Hydraulic valve	3 spool open center	3 spool open center
DIMENSIONS		
Length less bucket	2446 mm (96.3 in.)	2446 mm (96.3 in.)
Length with bucket	3048 mm (120 in.)	3048 mm (120 in.)
Width less bucket	1524 (60 in.)	1524 (60 in.)
Height to ROPS	1839 mm (72.4 in.)	1839 mm (72.4 in.)
Height to hinge pin	2822 mm (111.1 in.)	2822 mm (111.1 in.)
Dump height	2233 mm (87.9 in.)	2233 mm (87.9 in.)
Dump reach	514 mm (20.25 in.)	514 mm (20.25 in.)
Dump angle	45°	45°



	4475	5575
Bucket rollback	36°	36°
Wheelbase	950 mm (37.4 in.)	950 mm (37.4 in.)
Ground clearance	210 mm (8.25 in.)	210 mm (8.25 in.)
Angle of departure	26°	26°

a. Specifications and design subject to change without notice.

	6675	7775
ENGINE^a		
Make	John Deere Series 220	John Deere Series 220
Model	4020D001	4022D001
Type	Diesel	Diesel
Cylinders	4	4
Bore	84 mm (3.31 in.)	88 mm (3.46 in.)
Stroke	90 mm (3.54 in.)	90 mm (3.54 in.)
Displacement	2.0 L (124 cu. in.)	2.2 L (137 cu. in.)
Net horsepower	31 kW (42) @ 3000 rpm	37 kW (49) @ 3000 rpm
RPM, slow (no load)	900 - 1000	900 - 1000
RPM, fast (no load)	3125 - 3175	3125 - 3175
Lubrication	Full pressure	Full pressure
Crankcase capacity (with filter)	8.4 L (8.9 qt.)	8.4 L (8.9 qt.)
Cooling system	Liquid	Liquid
Coolant system capacity radiator and block	10.3 L (10.8 qt.)	10.3 L (10.8 qt.)
Air filter type	Dry paper with primary and secondary elements	Dry paper with primary and secondary elements
ELECTRICAL		
Type of starter	Solenoid shift	Solenoid shift
Battery voltage	12 V	12V
Battery reserve capacity at 27°C (80° F)	160 minutes	160 minutes
Battery cold cranking amps at -18°C (0°F)	625	625
Charging system	40 amp alternator	40 amp alternator

	6675	7775
Headlights	37.5 Watt Halogen	37.5 Watt Halogen
FUEL SYSTEM		
Fuel	Diesel # 1 or # 2	Diesel # 1 or # 2
Capacity	54.1 L (14.3 gal)	54.1 L (14.3 gal)
Fuel delivery	Inline direct injection	Inline direct injection
Fuel shut-off	Fuel shutoff solenoid	Fuel shutoff solenoid
POWER TRAIN		
Type	Hydrostatic	Hydrostatic
Charge pump	Gear	Gear
Hydrostatic pump	Variable displacement axial piston	Variable displacement axial piston
Hydrostatic pump relief pressure	23443-26201 kPa (3400-3800 psi)	23443-26201 kPa (3400-3800 psi)
Hydrostatic motor	Fixed displacement axial piston	Fixed displacement axial piston
Chain case capacity (each side)	7.6 L (2 gal.)	7.6 L (2 gal.)
Gearbox capacity (each gearbox box)	0.95 L (1 qt.)	0.95 L (1 qt.)
Brakes	Dry disk on hydrostatic motor shaft	Dry disk on hydrostatic motor shaft
STEERING		
Type	Power - hydrostatic	Power - hydrostatic
PERFORMANCE		
SAE operating load	758 kg (1670 lb.)	774 kg (1705 lb.)
Hydraulic lift capacity	908 kg (2000 lb.)	908 kg (2000 lb.)
Ground speed	0 - 11.7 km/h (0 - 7.3 mph)	0 - 11.9 km/h (0 - 7.4 mph)
Operating weight	2443 kg (5385 lb.)	2452 kg (5405 lb.)
HYDRAULICS		
Main system relief pressure	17927 kPa (2600 psi)	17927 kPa (2600 psi)
Circuit relief pressure	18961 kPa (2750 psi)	18961 kPa (2750 psi)
Charge relief pressure	758 kPa (110 psi)	758 kPa (110 psi)
Charge pump flow	56 L/min. (15 gmp)	64 L/min. (17 gmp)
Hydraulic valve	3 spool open center	3 spool open center
Built-in boom locks	Yes	Yes













	6675	7775
DIMENSIONS		
Length less bucket	2585 mm (101.8 in.)	2585 mm (101.8 in.)
Length with bucket	3218 mm (126.7 in.)	3218 mm (126.7 in.)
Width less bucket	1666 (65.6 in.)	1666 (65.6 in.)
Height to ROPS	1897 mm (74.7 in.)	1897 mm (74.7 in.)
Height to hinge pin	2934 mm (115.5 in.)	2934 mm (115.5 in.)
Operating height	3556 mm (140 in.)	3556 mm (140 in.)
Dump height	2296 mm (90.4 in.)	2296 mm (90.4 in.)
Dump reach	711 mm (28 in.)	711 mm (28 in.)
Dump angle	45°	45°
Bucket rollback	36°	36°
Wheelbase	1080mm (42.5 in.)	1080mm (42.5 in.)
Ground clearance	196 mm (7.7 in.)	196 mm (7.7 in.)
Angle of departure	26°	26°
Circle clearance	3454 mm (136 in.)	3454 mm (136 in.)

a. Specifications and design subject to change without notice.

UNIFIED INCH TORQUE VALUES



SAE Grade and Head Markings	1 or 2 ^b No Marks 	5  5.1  5.2 	8  8.2 
	2 No Marks 	5  	8  

TS1162

SIZE	Grade 1		Grade 2 ^b		Grade 5, 5.1 or 5.2		Grade 8 or 8.2									
	Lubricated ^a	Dry ^a	Lubricated ^a	Dry ^a	Lubricated ^a	Dry ^a	Lubricated ^a	Dry ^a								
	Nm	lb-ft	Nm	lb-ft	Nm	lb-ft	Nm	lb-ft								
1/4	3.7	2.8	4.7	3.5	6	4.5	7.5	5.5	9.5	7	12	9	13.5	10	17	12.5
5/16	7.7	5.5	10	7	12	9	15	11	20	15	25	18	28	21	35	26
3/8	14	10	17	13	22	16	27	20	35	26	44	33	50	36	63	46
7/16	22	16	28	20	35	26	44	32	55	41	70	52	80	58	100	75
1/2	33	25	42	31	53	39	67	50	85	63	110	80	120	90	150	115
9/16	48	36	60	45	75	56	95	70	125	90	155	115	175	130	225	160
5/8	67	50	85	62	105	78	135	100	170	125	215	160	215	160	300	225
3/4	120	87	150	110	190	140	240	175	300	225	375	280	425	310	550	400
7/8	190	140	240	175	190	140	240	175	490	360	625	450	700	500	875	650
1	290	210	360	270	290	210	360	270	725	540	925	675	1050	750	1300	975
1-1/8	470	300	510	375	470	300	510	375	900	675	1150	850	1450	1075	1850	1350
1-1/4	570	425	725	530	570	425	725	530	1300	950	1650	1200	2050	1500	2600	1950
1-3/8	750	550	950	700	750	550	950	700	1700	1250	2150	1550	2700	2000	3400	2550
1-1/2	1000	725	1250	925	990	725	1250	930	2250	1650	2850	2100	3600	2650	4550	3350

DO NOT use these values if a different torque value or tightening procedure is given for a specific application. Torque values listed are for general use only. Check tightness of fasteners periodically.

Shear bolts are designed to fail under predetermined loads. Always replace shear bolts with identical grade.

Fasteners should be replaced with the same or higher grade. If higher grade fasteners are used, these should only be tightened to the strength of the original. Make sure fasteners threads are clean and that you properly start thread engagement. This will prevent them from failing when tightening. Tighten plastic insert or crimped steel-type lock nuts to approximately 50 percent of the dry torque shown in the chart, applied to the nut, not to the bolt head.

Tighten toothed or serrated-type lock nuts to the full torque value.

^a "Lubricated" means coated with a lubricant such as engine oil, or fasteners with phosphate and oil coatings. "Dry" means plain or zinc plated without any lubrication^b

^b Grade 2 applies for hex cap screws (not hex bolts) up to 152 mm (6-in.) long. Grade 1 applies for hex cap screws over 152 mm (6-in.) long, and for all other types of bolts and screws of any length.

METRIC TORQUE VALUES



Property Class and Head Markings	4.8	8.8	9.8	10.9	12.9
Property Class and Nut Markings	5	10	10	12	

Ts1163

SIZE	Class 4.8		Class 8.8 or 9.8				Class 10.9				Class 12.9					
	Lubricated ^a		Dry ^a		Lubricated ^a		Dry ^a		Lubricated ^a		Dry ^a		Lubricated ^a		Dry ^a	
	Nm	lb-ft	Nm	lb-ft	Nm	lb-ft	Nm	lb-ft	Nm	lb-ft	Nm	lb-ft	Nm	lb-ft	Nm	lb-ft
M6	48	3.5	6	4.5	9	6.5	11	8.5	13	9.5	17	12	15	11.5	19	14.5
M8	12	8.5	15	11	22	16	28	20	32	24	40	30	37	28	47	35
M10	23	17	29	21	43	32	55	40	63	47	80	60	75	55	95	70
M12	40	29	50	37	75	55	95	70	110	80	140	105	130	95	165	120
M14	63	47	80	60	120	88	150	110	175	130	225	165	205	150	260	109
M16	100	73	125	92	190	140	240	175	275	200	350	225	320	240	400	300
M18	135	100	175	125	260	195	330	250	375	275	475	350	440	325	560	410
M20	190	140	240	180	375	275	475	350	530	400	675	500	625	460	800	580
M22	260	190	330	250	510	375	650	475	725	540	925	675	850	625	1075	800
M24	330	250	425	310	650	475	825	600	925	675	1150	850	1075	800	1350	1000
M27	490	360	625	450	950	700	1200	875	1350	1000	1700	1250	1600	1150	2000	1500
M30	675	490	850	625	1300	950	1650	1200	1850	1350	2300	1700	2150	1600	2700	2000
M33	900	675	1150	850	1750	1300	2200	1650	2500	1850	3150	2350	2900	2150	3700	2750
M36	1150	850	1450	1075	2250	1650	2850	2100	3200	2350	4050	3000	3750	2750	4750	3500

DO NOT use these values if a different torque value or tightening procedure is given for a specific application. Torque values listed are for general use only. Check tightness of fasteners periodically.

Shear bolts are designed to fail under predetermined loads. Always replace shear bolts with identical grade.

Fasteners should be replaced with the same or higher grade. If higher grade fasteners are used, these should only be tightened to the strength of the original. Make sure fasteners threads are clean and that you properly start thread engagement. This will prevent them from failing when tightening.

Tighten plastic insert or crimped steel-type lock nuts to approximately 50 percent of the dry torque shown in the chart, applied to the nut, not to the bolt head. Tighten toothed or serrated-type lock nuts to the full torque value.

^a "Lubricated" means coated with a lubricant such as engine oil, or fasteners with phosphate and oil coatings. "Dry" means plain or zinc plated without any lubrication.

^b Grade 2 applies for hex cap screws (not hex bolts) up to 152 mm (6-in.) long. Grade 1 applies for hex cap screws over 152 mm (6-in.) long, and for all other types of bolts and screws of any length.

DIESEL FUEL SPECIFICATIONS

Use only clean, high quality fuel.

Use Grade No. 2-D fuel at temperatures above 4°C (40°F).

Use Grade No. 1-D fuel at temperatures below 4°C (40°F).

Use Grade No. 1-D fuel for all air temperatures at altitudes above 1500 m (5000 ft).

IMPORTANT: Use fuel with less than 1.0 per cent sulfur. If possible, use fuel with less than 0.5 per cent sulfur. If fuel sulfur is more than 0.5 per cent, change engine oil and filter every 100 hours.

For maximum filter life, sediment and water should not be more than 0.10 percent.

The cetane number should be 40 minimum. If you operate your tractor where air temperatures are normally low or where altitudes are high, you may need fuel with a higher cetane number.

Cloud Point - For cold weather operation, cloud point should be 10°F (6°C) below lowest normal air temperature.

Fuel Tank Capacity

4475 and 5575.....37.8 L (10 gal)
 6675 and 7775..... 54.1 L (14.3 gal)

DIESEL FUEL STORAGE

NOTE: Diesel fuels stored for a long time may form gum and plug filters.

Keep fuel in a clean container in a protected area. Water and sediment must be removed before fuel gets to the engine. Do not use de-icers to remove water from fuel. Do not depend on fuel filters to remove water. If possible, install a water separator at the storage tank outlet. (See your John Deere dealer for this part.)

IMPORTANT: Keep all dirt, scale, water or other foreign material out of fuel.

Store fuel drum on its side with plug up.

DO NOT STORE DIESEL FUEL IN GALVANIZED CONTAINERS

IMPORTANT: Diesel fuel stored in galvanized containers reacts with the zinc coating of the container to form zinc flakes. If fuel contains any water, a zinc gel will also form. The gel and flakes will quickly plug fuel filters and may damage fuel injectors and fuel pumps.



Store diesel fuel in:

- plastic containers
- aluminum containers
- specially coated steel containers made for diesel fuel.

DO NOT USE BRASS-COATED CONTAINERS: brass is an alloy of copper and zinc.

CONTENTS

Page

DIESEL ENGINE

SPECIFICATIONS — 3015D001 (3TNE84)	5
GENERAL SPECIFICATIONS	5
REPAIR SPECIFICATIONS	5
CHECKS, TESTS AND ADJUSTMENTS	11
OPERATIONAL TESTS	12
SPECIFICATIONS - 4020D001 (4TNE84)	13
GENERAL SPECIFICATIONS	13
REPAIR SPECIFICATIONS	13
CHECKS, TESTS AND ADJUSTMENTS	19
OPERATIONAL TESTS	20
SPECIFICATIONS - 3017D001 (3TNE88)	21
GENERAL SPECIFICATIONS	21
REPAIR SPECIFICATIONS	22
CHECKS, TESTS AND ADJUSTMENTS	28
OPERATIONAL TESTS	29
SPECIFICATIONS - 4022D001 (4TNE88)	30
GENERAL SPECIFICATIONS	30
REPAIR SPECIFICATIONS	30
CHECKS, TESTS AND ADJUSTMENTS	36
OPERATIONAL TESTS	37
ENGINE COMPONENT LOCATION	38
THEORY OF OPERATION	39
COOLING SYSTEM OPERATION	39
LUBRICATION SYSTEM OPERATION	40
FUEL AND AIR SYSTEM OPERATION	42
TROUBLESHOOTING	44
ENGINE SYSTEM DIAGNOSIS	46
CHECKS, TESTS AND ADJUSTMENTS	48
CYLINDER COMPRESSION PRESSURE TEST	48
THROTTLE CONTROL ADJUSTMENT	48
FUEL SHUTOFF SOLENOID ADJUSTMENT	49
SLOW IDLE ADJUSTMENT	49
FAST IDLE ADJUSTMENT	50
INJECTION PUMP TIMING ADJUSTMENT	50
VALVE CLEARANCE CHECK AND ADJUSTMENT	51
CONNECTING ROD SIDE PLAY CHECK	52
CONNECTING ROD BEARING CLEARANCE CHECK	52
CRANKSHAFT END PLAY CHECK	53
CRANKSHAFT MAIN BEARING CLEARANCE CHECK	54
VALVE LIFT CHECK	54
CAMSHAFT END PLAY CHECK	55
TIMING GEAR BACKLASH CHECK	55
FUEL INJECTION NOZZLE TEST (HOLE-TYPE)	56





Download the full PDF manual instantly.

Our customer service e-mail:

aservicemanualpdf@yahoo.com