

Product: VIBRATORY COMPACTOR

Model: CB-534C VIBRATORY COMPACTOR 1WS

Configuration: CB-534C Vibratory Compactor 1WS00001-UP (MACHINE) POWERED BY 3054 Engine

Disassembly and Assembly 3054 Engine for Caterpillar Built Machines

Media Number -SEN6241-13

Publication Date -01/08/2008

Date Updated -04/08/2008

i04406238

Flywheel - Remove

SMCS - 1156-011

Removal Procedure

Table 1

Required Tools			
Tool	Part Number	Part Description	Qty
A	138-7575	Link Bracket	1

NOTICE

Keep all parts clean from contaminants.

Contaminants may cause rapid wear and shortened component life.



Typical Example. Different lifting device shown than what is called out in the Table.



Illustration 2

g00546793

1. Install Tool (A) and a suitable lifting device on flywheel (1) .
2. Remove bolts (3) and bearing housing (4) .
3. Remove six bolts (2) and the washers from the flywheel.

Note: The 3054 and 3056 marine engines used several bolt patterns to attach the flywheel to the crankshaft. There are drilled holes that are not used in the crankshaft and in the flywheel.

4. Use the suitable lifting device in order to remove flywheel (1) . The weight of flywheel (1) and the flywheel ring gear is 53 kg (120 lb).
5. If removal of the flywheel ring gear is necessary, place an index mark on the chamfer of the flywheel ring gear for the installation process.



Illustration 3

g00546795

6. Use a hammer and a punch in order to remove flywheel ring gear (5) from flywheel (1) .

Product: VIBRATORY COMPACTOR

Model: CB-534C VIBRATORY COMPACTOR 1WS

Configuration: CB-534C Vibratory Compactor 1WS00001-UP (MACHINE) POWERED BY 3054 Engine

Disassembly and Assembly 3054 Engine for Caterpillar Built Machines

Media Number -SEN6241-13

Publication Date -01/08/2008

Date Updated -04/08/2008

i04406239

Flywheel - Install

SMCS - 1156-012

Installation Procedure

Table 1

Required Tools			
Tool	Part Number	Part Description	Qty
A	138-7575	Link Bracket	1



WARNING

Always wear protective gloves when handling parts that have been heated.

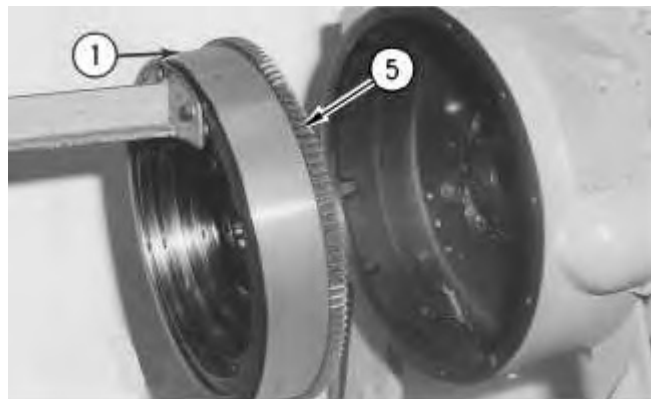

Typical Example. Different Lifting device shown than what is called out in the table.

1. If flywheel ring gear (5) was removed, heat flywheel ring gear (5) to a temperature of 250 °C (480 °F).

Note: Do not use a torch to heat the flywheel ring gear.

2. Install flywheel ring gear (5) on flywheel (1) .

Note: Ensure that the chamfer of the flywheel ring gear is in the correct position on the flywheel.

3. Install Tool (A) and a suitable lifting device on flywheel (1) and position flywheel (1) in the flywheel housing. The weight of flywheel (1) and flywheel ring gear (5) is 53 kg (120 lb).



Illustration 2

g00546793

4. Install six bolts (2) and the washers that hold flywheel (1) in position. Tighten the bolts to a torque of 105 N·m (77 lb ft).
5. Put bearing housing (4) in position on the flywheel. Install four bolts (3) that fasten bearing housing (4) to the flywheel.
6. Refer to the Specifications Module, "Flywheel" topic for information on inspecting the flywheel.

Product: VIBRATORY COMPACTOR

Model: CB-534C VIBRATORY COMPACTOR 1WS

Configuration: CB-534C Vibratory Compactor 1WS00001-UP (MACHINE) POWERED BY 3054 Engine

Disassembly and Assembly 3054 Engine for Caterpillar Built Machines

Media Number -SEN6241-13

Publication Date -01/08/2008

Date Updated -04/08/2008

i01741403

Crankshaft Rear Seal - Remove

SMCS - 1161-011

Removal Procedure

Start By:

- a. Remove the flywheel. Refer to Disassembly and Assembly, "Flywheel - Remove".

NOTICE

Keep all parts clean from contaminants.

Contaminants may cause rapid wear and shortened component life.

NOTICE

Care must be taken to ensure that fluids are contained during performance of inspection, maintenance, testing, adjusting and repair of the product. Be prepared to collect the fluid with suitable containers before opening any compartment or disassembling any component containing fluids.

Refer to Special Publication, NENG2500, "Caterpillar Dealer Service Tool Catalog" for tools and supplies suitable to collect and contain fluids on Caterpillar products.

Dispose of all fluids according to local regulations and mandates.

Engines with 14 Bolt Housing Assembly

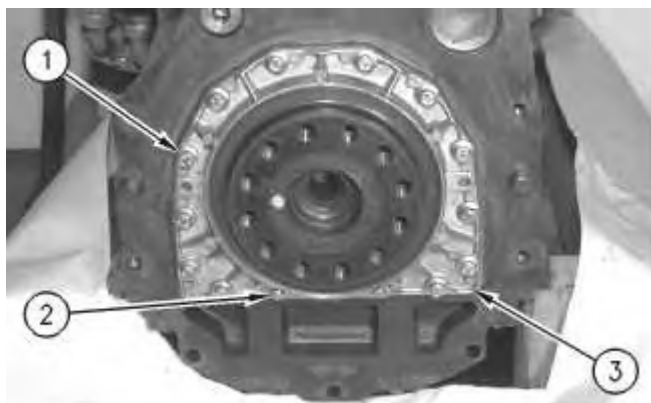

Illustration 1

g00632744

The flywheel housing has been removed for photographic purposes only.

1. Remove bolts (1) from housing (3).
2. Remove socket head bolts (2) from housing (3).
3. Remove the crankshaft rear seal, the gasket, and housing (3) from the dowels in the cylinder block.

Engines with 10 Bolt Housing Assembly

Note: The 10 bolt housing assembly is manufactured as a one-piece assembly. The 10 bolt housing assembly is NOT adaptable to engines that have the 14 bolt housing assembly.

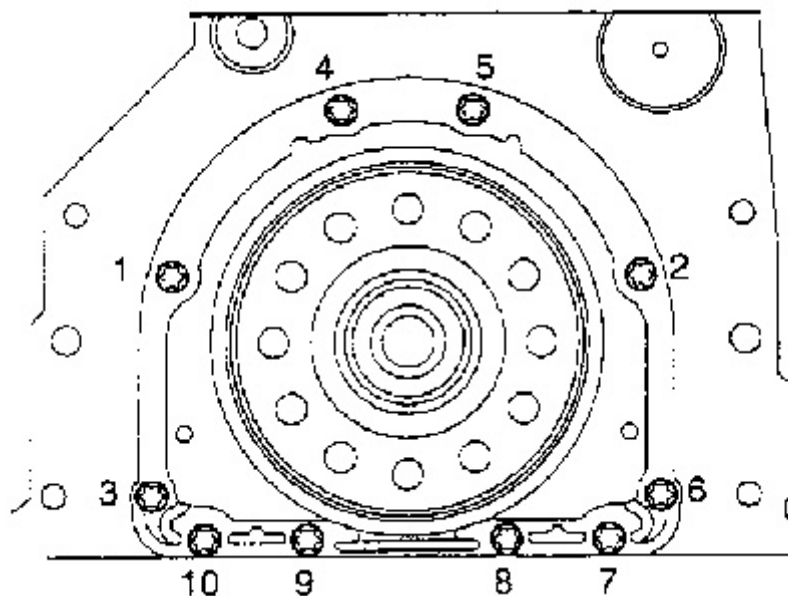

Illustration 2

g00830867

1. Remove the bolts in reverse order of the numbered sequence. Refer to Illustration 2.
 2. Remove the one-piece housing assembly from the cylinder block.
-



Download the full PDF manual instantly.

Our customer service e-mail:

aservicemanualpdf@yahoo.com