

Assembly Procedure

Table 1

Required Tools			
Tool	Part Number	Part Description	Qty
A	1P-2420	Transmission Repair Stand	1
B	138-7573	Link Bracket	2
C	1P-1863	Retaining Ring Pliers	1
D	208-6033	Spanner Socket As	1
	208-6034	Spacer	1
E	138-7574	Link Bracket	2
H	6V-7030	Micrometer Depth Gauge Group	1
J	FT-2770	Leak Down Test Tool	1
K	1U-6396	O-Ring Assembly Compound	1
L	5P-3931	Anti-Seize Compound	1
M	1U-8846	Gasket Sealant	1
N	8T-9206	Duo-Cone Seal Installer As	1
P	5P-3931	Anti-Seize Compound	1
Q	235-4848	Drill Fixture Gp	1
R	9S-3263	Thread Lock Compound	1

Note: Cleanliness is an important factor. Before assembly, all parts should be thoroughly cleaned in cleaning fluid. Allow the parts to air dry. Wiping cloths or rags should not be used to dry parts. Lint may be deposited on the parts which may cause later trouble. Inspect all parts. If any parts are worn or damaged, use new parts for replacement. All disassembly and all assembly procedures must be performed on a clean work surface and in a clean hydraulic area. Keep cleaned parts covered and protected at all times.

Note: O-ring seals, gaskets, and seals should always be replaced. A used O-ring seal may not have the same sealing properties as a new O-ring. Use Tooling (K) during the assembly procedure.

Note: Apply a light film of hydraulic oil to all components before assembly.

Note: Some of the images that are in this procedure do not show the sprocket assembly that is attached to the final drive housing. If necessary, the weights that are given include the weight of the sprocket assembly.

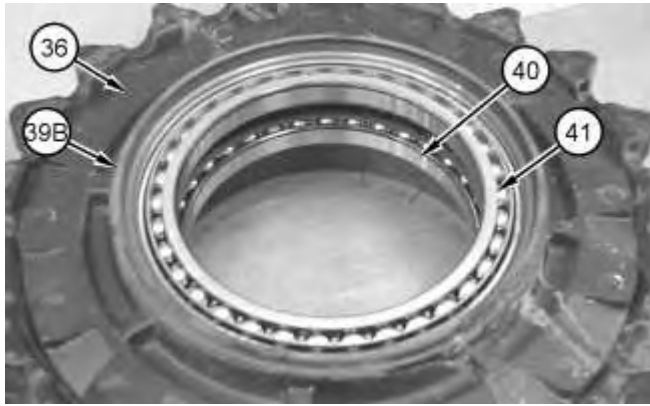

Illustration 1

g01147975

1. Apply Tooling (P) to the outer diameter of the bearings.
2. Use a suitable press to Install bearings (40) and (41). Make sure that bearing (41) and bearing (40) contact the counterbore in housing (36).
3. Use Tooling (N) to install Duo-Cone seal (39B).



Illustration 2

g01147981

4. Use Tooling (N) to install Duo-Cone seal (39A) onto housing (38).



Illustration 3

g01147930

5. Use Tooling (E) and a suitable lifting device to install housing (36) onto housing (38). The weight of housing (36) is approximately 100 kg (220 lb).
6. Remove Tooling (E) from housing (36).



Illustration 4

g01147724

7. Install stopper plate (35). Do not tighten stopper plate assembly (35) at this time.

Note: Stopper plate (35) will secure housing (36) to housing (38).

8. Install Tooling (E) and a suitable lifting device to housing (36). The combined weight of housing assembly (36) and (38) is approximately 120 kg (265 lb). Install housing assembly (36) and (38) in a suitable press.
9. Remove stopper plate (35).



Illustration 5

g01147727

10. Assemble Tooling (D), as shown.
-

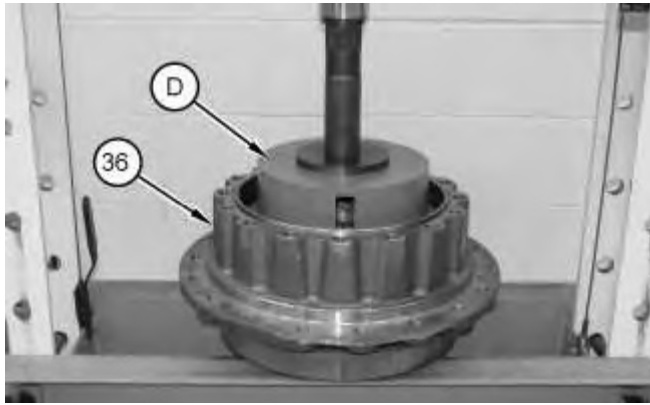

Illustration 6

g01147731

11. Install Tooling (D) into housing (36), as shown.
12. Apply a force of 4000 kg (8818 lb) to the top of Tooling (D). Rotate housing (36) to seat the bearings.
13. Reduce the force on the top of Tooling (D) to 3000 kg (6615 lb).

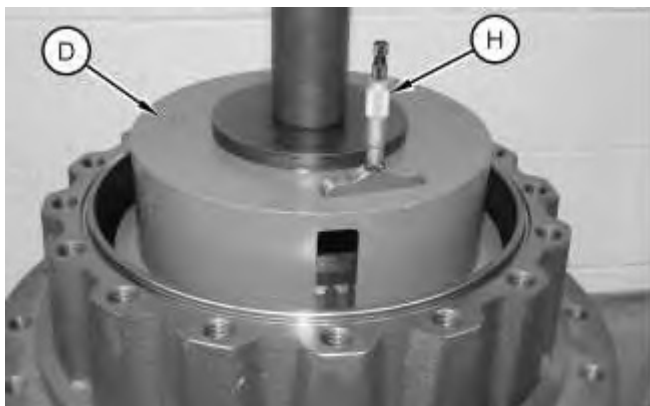

Illustration 7

g01147737

14. Use Tooling (H) to take a measurement in three locations. Average the three measurements and record the average measurement as Dimension (W).
15. Remove Tooling (D).
16. Separate Tooling (D).

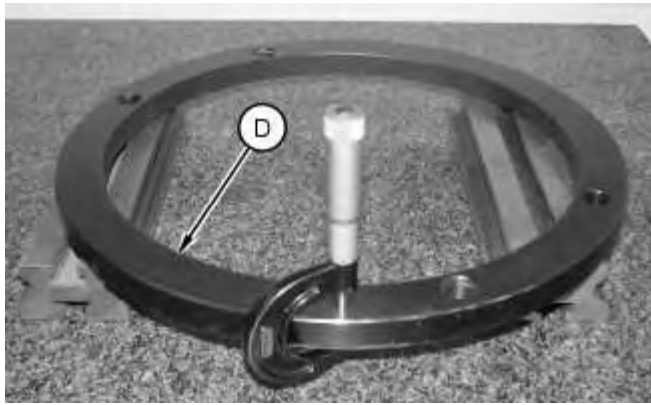

Illustration 8

g01147743

17. Use a micrometer to measure the thickness at three locations of the spacer from Tooling (D). Record the average measurement as Dimension (X).



Illustration 9

g01147742

18. Use a micrometer to measure the thickness at three locations of stopper plate (35). Record the average measurement as Dimension (Y).
19. Subtract Dimension (X) from Dimension (Y) and record this figure as Dimension (Z).



Illustration 10

g01147724

20. Install stopper plate (35) onto housing (38). Do not tighten stopper plate (35) at this time. Stopper plate (35) will secure the final drive assembly while the final drive assembly is repositioned onto Tooling (A).
21. Use Tooling (E) and a suitable lifting device to reposition the final drive assembly onto Tooling (A). The combined weight of housing assembly (36) and (38) is approximately 120 kg (265 lb).
22. Secure the final drive assembly to Tooling (A).

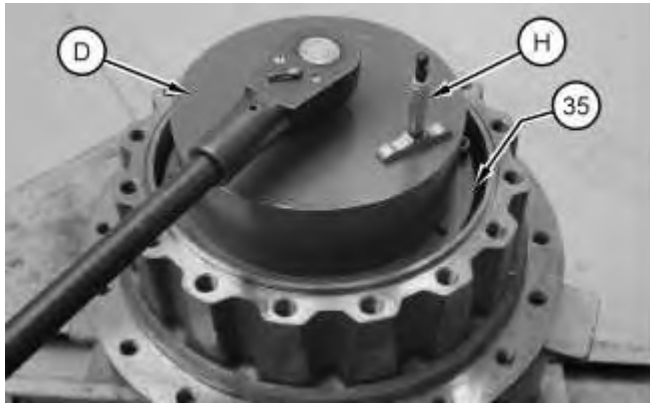

Illustration 11

g01148004

23. Secure the spanner socket from Tooling (D) to stopper plate (35).
24. to determine the final bearing preload, add Dimension (W) to Dimension (Z) and record this figure as Dimension (V).
25. Use Tooling (H) to measure the distance in three locations.
26. Tighten stopper plate (35) until the average of the measurements is equal to Dimension (V).
27. Remove Tooling (D).



Illustration 12

g01372092

28. Install Tooling (Q) and a suitable vacuum onto stopper plate (35).
-

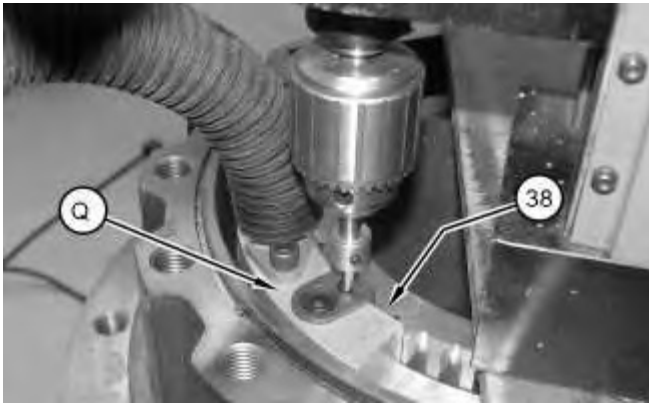

Illustration 13

g01147789

29. Use a suitable drill and Tooling (Q) to drill a hole to the depth of 15 mm (0.6 inch) in the stopper plate and in housing (38).

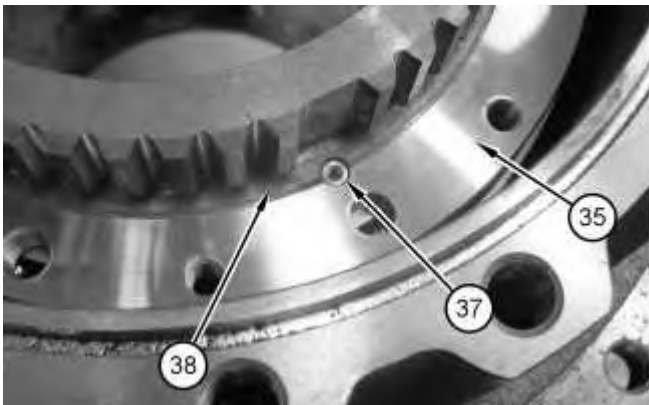

Illustration 14

g01147796

30. Install dowel (37).

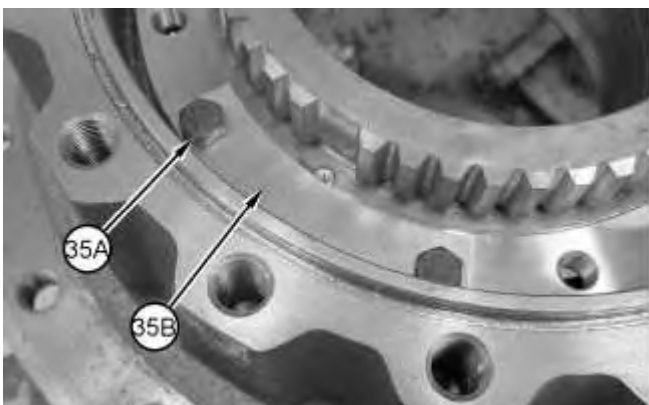

Illustration 15

g01147650

31. Apply Tooling (R) to bolts (35A). Install plate (35B) and bolts (35A).
32. Repeat Steps 28 through 31 for the opposite side of stopper plate (35).



Illustration 16

g00781807

33. Install O-ring seal (34) on housing (36).



Illustration 17

g00781730

34. Install gear (33) on housing (36).



Illustration 18

g00781719

35. Assemble carrier assembly (27), as follows.

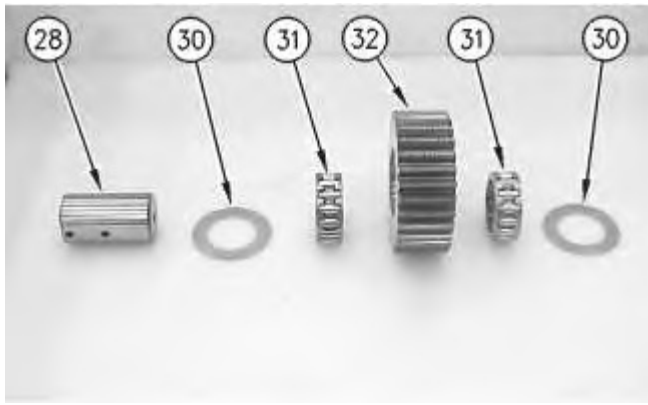

Illustration 19

g00781607

- a. Use a deburring tool to remove the metal burr from the openings in the carrier.
- b. Install two bearings (31) in planetary gear (32).
- c. Install thrust washers (30) and planetary gear (32) in the carrier assembly.
- d. Install planetary shaft (28) in the carrier assembly.
- e. Align the split in spring pin (29) to the top or to the bottom. Make a stake mark on each side of the spring pin hole in the carrier. Each stake mark should be approximately 1.50 mm (0.059 inch) from the outside diameter of the spring pin hole.

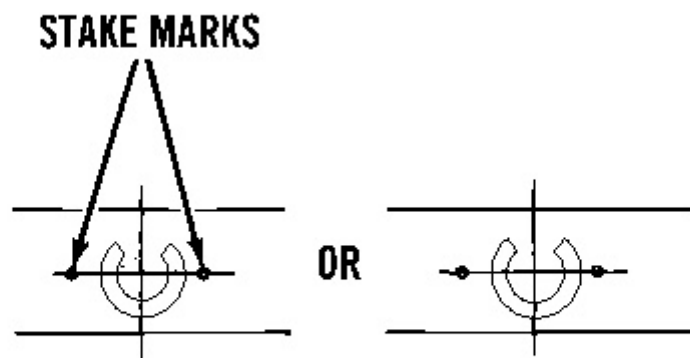

Illustration 20

g00903073

- f. Drive spring pin (29) into planetary shaft (28) with a hammer and a punch.
36. Repeat Steps 35.a through 35.e to install the other two planetary gears in the carrier.

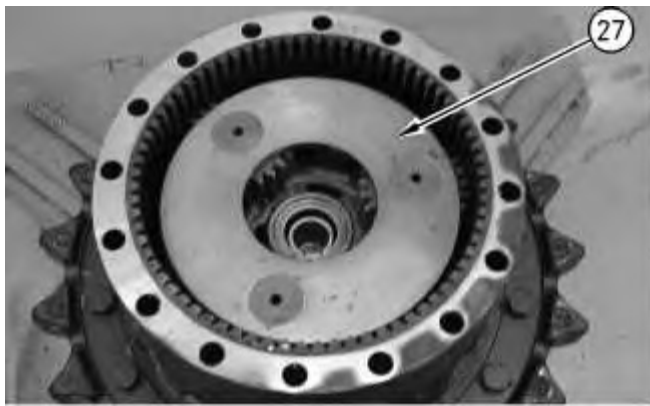

Illustration 21

g00781559

37. Use two people to install carrier assembly (27) in gear (33). The weight of carrier assembly (27) is approximately 38 kg (85 lb).

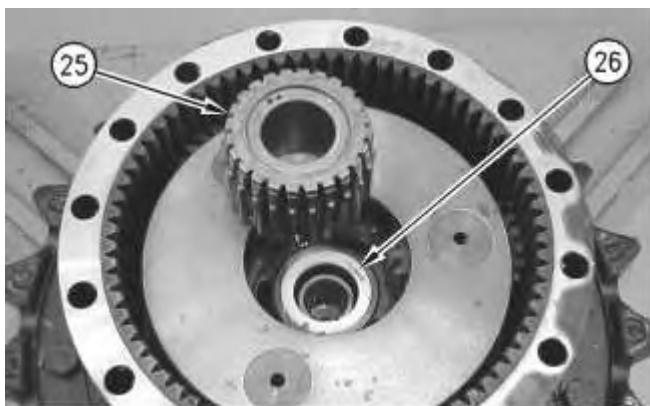

Illustration 22

g00781529

38. Install spacer (26). Install gear (25).



Illustration 23

g01148010

39. Assemble carrier assembly (19), as follows.

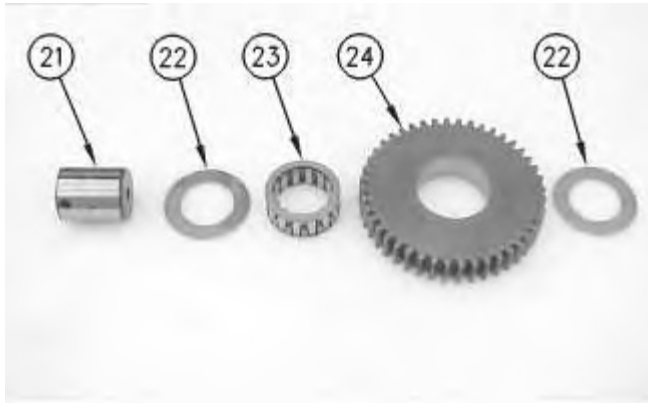

Illustration 24

g00781516

- a. Use a deburring tool to remove the metal burr from the openings in the carrier.
- b. Install bearing (23) in planetary gear (24).
- c. Install thrust washers (22) and planetary gear (24) in the carrier assembly.
- d. Install planetary shaft (21) in the carrier assembly.

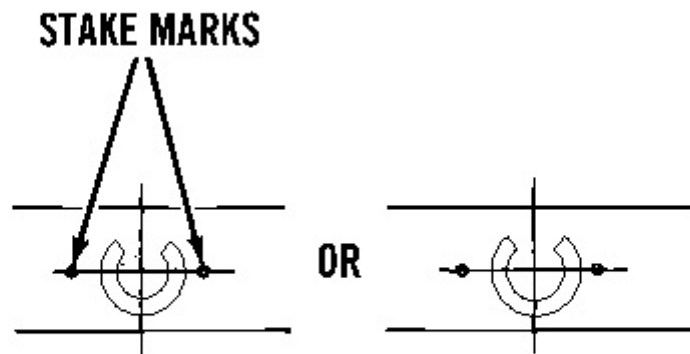

Illustration 25

g00903073

- e. Drive spring pin (20) into planetary shaft (21) with a hammer and a punch.

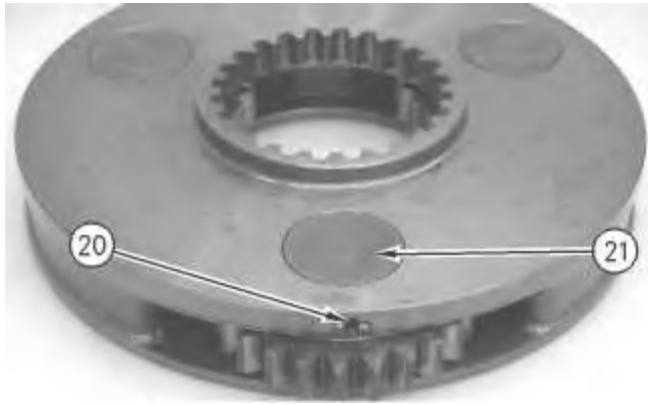

Illustration 26

g00879368

- f. Align the split in the spring pin to the top or to the bottom. Make a stake mark on each side of the spring pin hole in the carrier. Each stake mark should be approximately 1.50 mm (0.059 inch) from the outside diameter of the spring pin hole.
- g. Repeat Steps 39.a through 39.f to install the other two planetary gears in the carrier.



Illustration 27

g01148011

40. Install carrier assembly (19) into gear (33).
41. Install retaining ring (18).

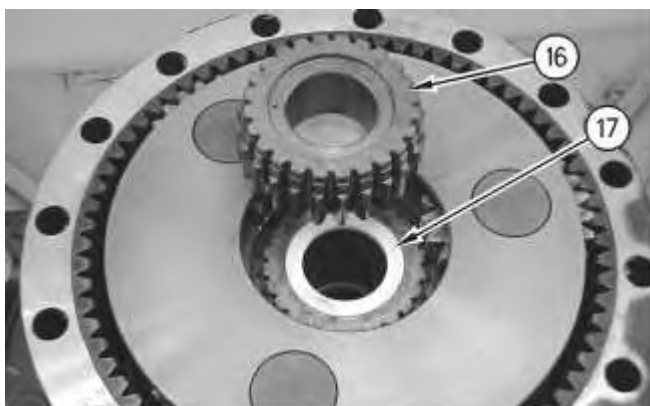

Illustration 28

g00781412

42. Install spacer (17). Install gear (16).

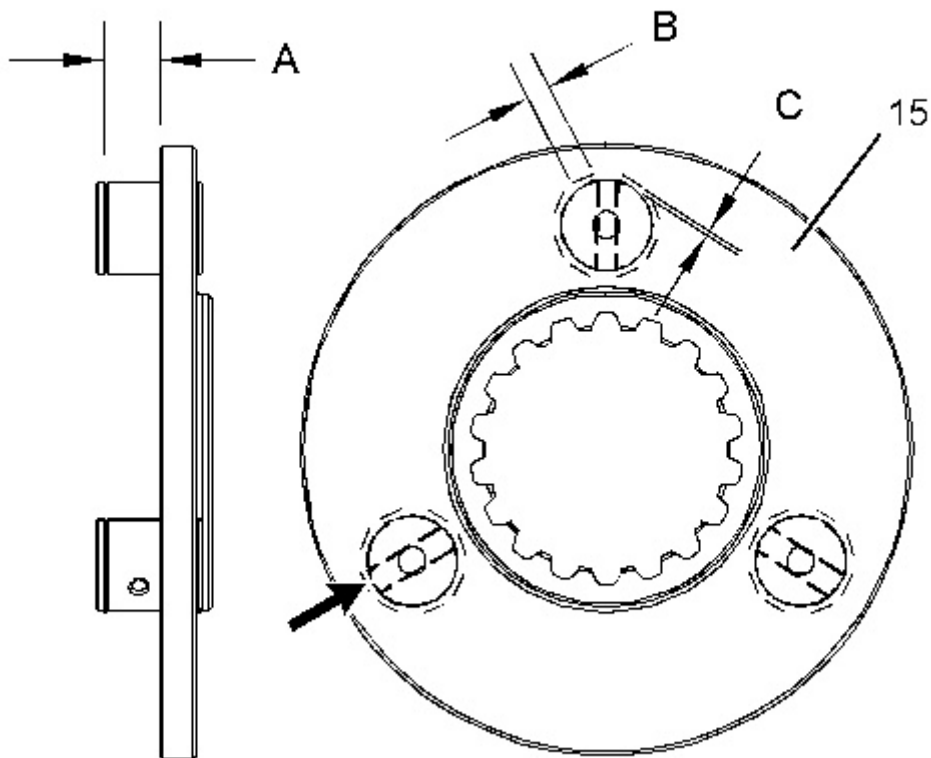

Illustration 29

g01389598

Note: Make sure that the oil passages in the shafts are oriented toward the center of carrier assembly (15).

43. Raise the temperature of carrier assembly (15). Lower the temperature of the shafts. Install the shafts into carrier assembly (15) until the groove of the shafts is at Dimension (A). Dimension (A) equals 25.00 ± 0.10 mm (0.984 ± 0.004 inch).
 44. Make eight stake marks at distance of Dimension (C) from each shaft. Dimension (C) equals 2.0 ± 1.0 mm (0.08 ± 0.04 inch). The width of each stake mark should be equal to Dimension (B). Dimension (B) equals 4.0 ± 1.0 mm (0.16 ± 0.04 inch).
-



Illustration 30

g00781407

45. Assemble carrier assembly (15), as follows.

- a. Install carrier assembly in position on gear (16).

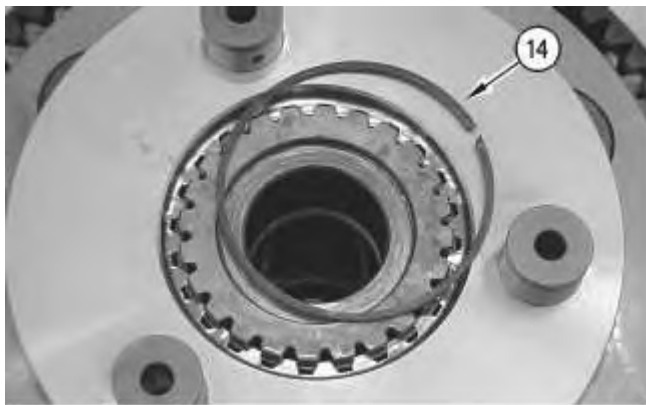

Illustration 31

g00781401

- b. Install retaining ring (14) onto gear (16).



Illustration 32

g00780432

- c. Install washer (11). Install bearing assembly (13). Install gear (12). Install washer (11). Install retaining ring (10) with Tooling (C).

d. Repeat Steps 45.a through 45.c for the other two planetary gears.

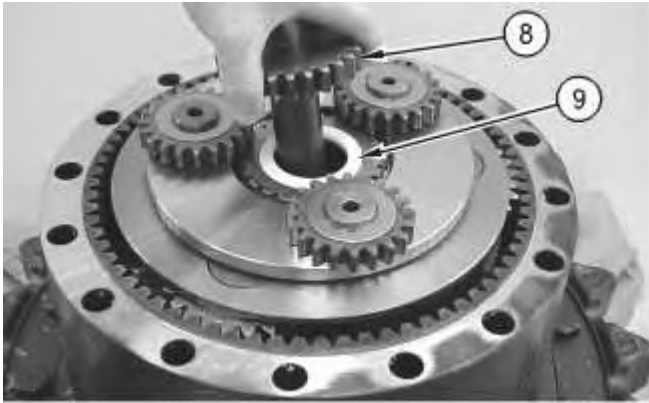

Illustration 33

g00780428

46. Install spacer (9). Install gear (8).



Illustration 34

g00879365

47. Install O-ring seal (7) on plugs (4).

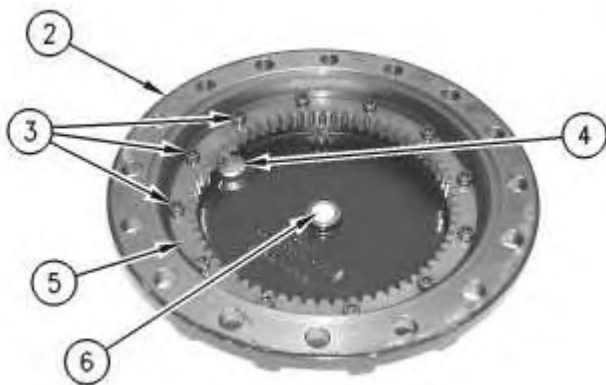

Illustration 35

g00879362

48. Install plugs (4) and spacer (6) in cover (2).

49. Position gear (5). Install bolts (3).

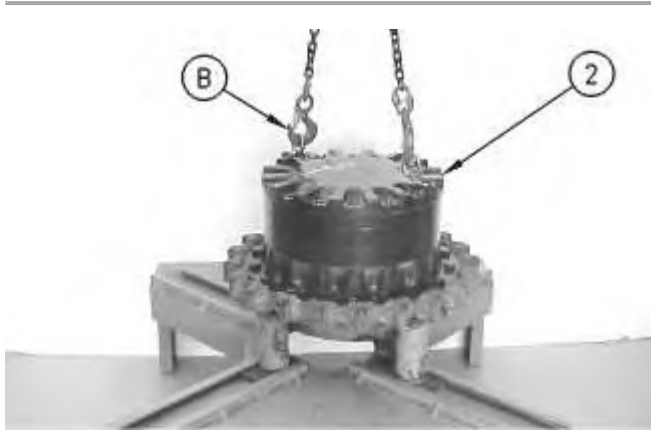

Illustration 36

g00708090



Illustration 37

g00708089

50. Place a piece of solder in the center of gear (8).

Note: You may need to apply some grease to the solder to keep the solder in position on gear (8).

51. Use Tooling (B) and a suitable lifting device to Install cover (2). The weight of cover (2) is approximately 32 kg (70 lb).

52. Install four bolts (1) at 90 degrees from each other. Tighten bolts (1) in a crisscross pattern to a torque of $420 \pm 60 \text{ N}\cdot\text{m}$ ($310 \pm 44 \text{ lb ft}$). Turn bolts (1) an additional 60 ± 5 degrees.

53. Remove bolts (1).

54. Use Tooling (B) and a suitable lifting device to remove cover (2). The weight of cover (2) is approximately 32 kg (70 lb).

55. Use a micrometer to measure the thickness of the solder. Record this measurement to determine the thickness of the shims for plate (6). Adjust the shims to obtain a clearance of $1.000 + 1.000 \text{ mm}$ ($0.0394 + 0.0394 \text{ inch}$) between plate (6) and gear (8).

56. Apply Tooling (M) to the mating surfaces of cover (2) and the housing.

57. Use Tooling (B) and a suitable lifting device to Install cover (2). The weight of cover (2) is approximately 32 kg (70 lb).
58. Apply Tooling (R) to bolts (1). Install bolts (1) and the washers. Tighten bolts (1) in a crisscross pattern to a torque of $900 \pm 100 \text{ N}\cdot\text{m}$ ($664 \pm 74 \text{ lb ft}$).

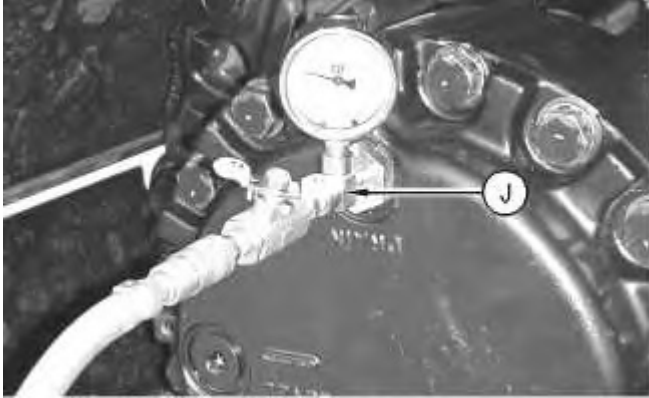

Illustration 38

g00783362

59. Remove plug (4) (not shown). Attach Tooling (J) to cover (2). Reduce the air pressure at the source to 103 kPa (15 psi). Apply air pressure to Tooling (J). This air will test the Duo-Cone seals.
60. Use the ball valve on Tooling (J) to eliminate the air pressure to the final drive. A pressure of 98 kPa (14.2 psi) must be maintained for 30 seconds.
61. Remove Tooling (J). Install plug (6). Torque plug (6) to $80 \pm 10 \text{ N}\cdot\text{m}$ ($59 \pm 7 \text{ lb ft}$).
62. Remove the final drive from Tooling (A). The weight of the final drive assembly is approximately 310 kg (683 lb).

End By:

- a. If necessary, install the final drive sprocket. Refer to Disassembly and Assembly, "Final Drive Sprocket - Remove and Install".
 - b. Install the final drive. Refer to Disassembly and Assembly, "Final Drive - Install".
-

Assembly Procedure

Table 1

Required Tools			
Tool	Part Number	Part Description	Qty
A	439-3940	Link Bracket	3
B	439-3939	Link Bracket	2
D	8T-9206	Duo-Cone Seal Installer As	1
	169-0503	Installation Kit	1
E	1U-9895	Crossblock	1
F	-	Loctite Copper Anti Seize	-
G	-	Loctite 243	-
H	-	Loctite RTV Silicone Clear	-
J	FT-2770	Leak Down Test Tool	1
K	6V-2012	Depth Micrometer	1
L	6V-7059	Micrometer	1

1. Make sure that all parts of the final drive are thoroughly clean and free of dirt and debris prior to assembly. Check the condition of all O-ring seals that are used in the final drive. If any of the seals are damaged, use new parts for replacement.

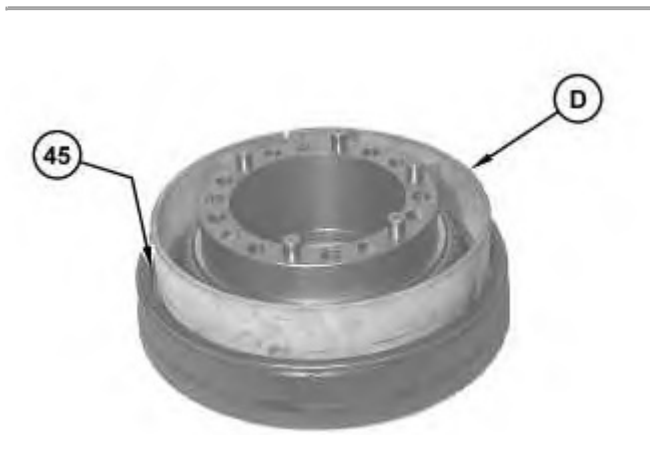

2. Use Tooling (D) to install Duo-Cone seal (45) .



3. Apply Tooling (F) to the surface of dowels (46) . Install dowels (46) .
4. Raise the temperature of lower bearing cone (47) . Install lower bearing cone (47) on motor housing (48) .



5. Lower the temperature of bearing cups (43) . Install bearing cups (43) in sprocket housing (41) .
-



Illustration 4

g03873145

6. Use Tooling (D) to install Duo-Cone seal (44) .

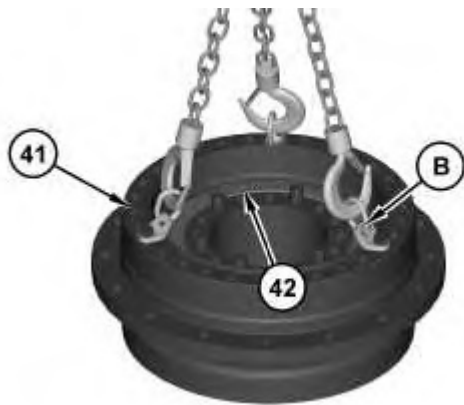
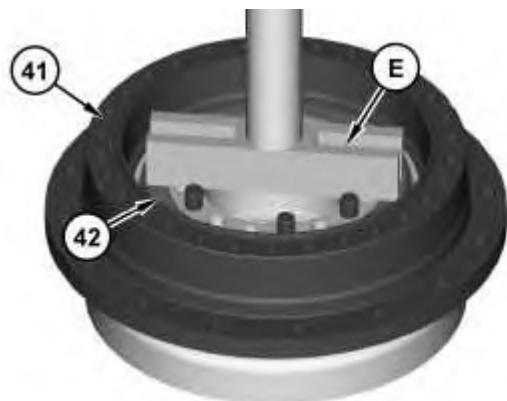
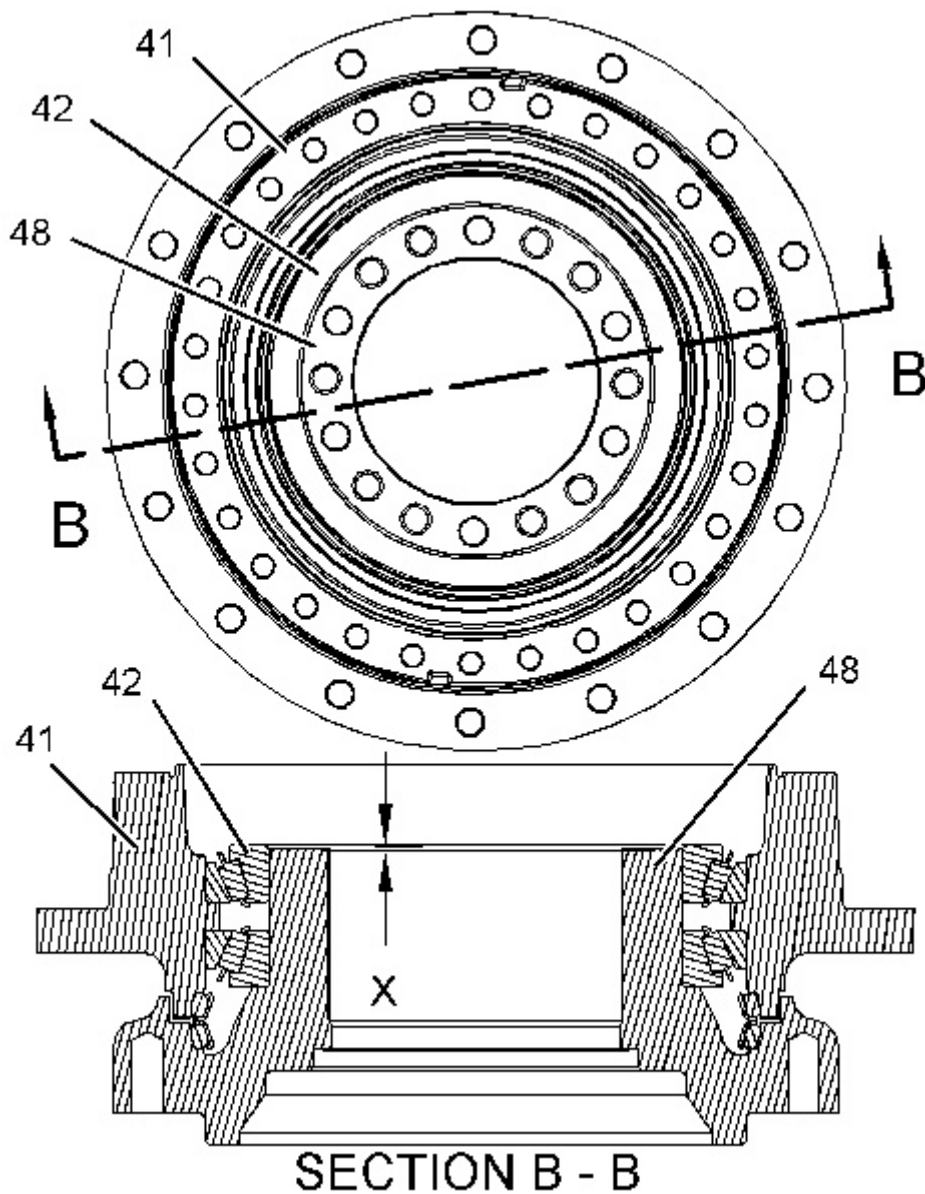

Illustration 5

g03873151

7. Attach Tooling (B) and a suitable lifting device to sprocket housing (41) . The weight of sprocket housing (41) is approximately 110 kg (243 lb). Install sprocket housing (41) .
8. Raise the temperature of upper bearing cone (42) . Install upper bearing cone (42) .





9. Use Tooling (E) and a suitable press in order to apply force to upper bearing cone (42) . Apply a force of 4000 kg (8818 lb) to the top of Tooling (E) . Rotate sprocket housing (41) in order to seat the roller bearings.
10. Reduce the force on top of Tooling (E) to 3000 ± 300 kg (6614 ± 661 lb). Use Tooling (K) in order to measure Dimension (X) . Record Dimension (X) .



Illustration 8

g03873199

11. Remove Tooling (E) .
12. Use Tooling (K) in order to measure Dimension (W) on coupling gear (39) . Record Dimension (W) .



Illustration 9

g03873204



Illustration 10

g03873207

13. Subtract Dimension (X) from Dimension (W) and record the difference as Dimension (V) . The correct shim thickness is Dimension (V) . Use Tooling (L) in order to measure the correct thickness of shims (40) . The tolerance of Dimension (V) is 0 ± 0.05 mm (0.0 ± 0.002 inch).

Note: Use a maximum of two shims (40) . If two shims (40) are used to achieve the proper dimension, install the thinner of the two shims toward coupling gear (39) .

14. Install shims (40) .
15. Apply Tooling (G) to the threads of bolts (38) . Install coupling gear (39) and bolts (38) . Tighten bolts (38) to a torque of 900 ± 100 N·m (665 ± 75 lb ft).

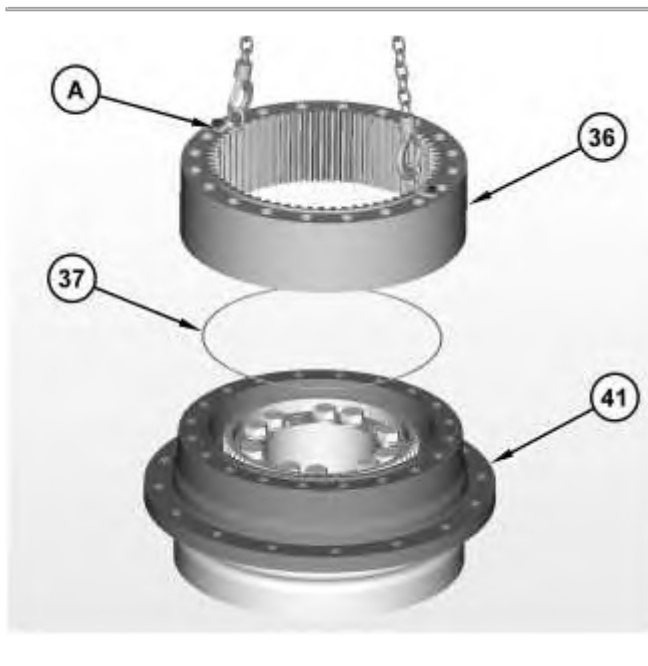

Illustration 11

g03873246

16. Install O-ring seal (37) in sprocket housing (41) .
 17. Thoroughly clean the mating surface of sprocket housing (41) that makes contact with ring gear (36) .
 18. Attach Tooling (A) and a suitable lifting device to ring gear (36) . Put ring gear (36) in position on sprocket housing (41) . The weight of ring gear (36) is approximately 65 kg (143 lb). Make sure that the alignment marks on sprocket housing (38) and ring gear (36) are lined up with each other.
-



Download the full PDF manual instantly.

Our customer service e-mail:

aservicemanualpdf@yahoo.com