

SENA 2000

Shop
Manual
2002

Volume **1**

GTI 5558/5559
GTI California 6116
GTI LE 5560/5561
GTI LE California 6117

GTX 5587/5588
GTX RFI 5565/5566
RX 5579/5580/5581/5582
RX DI 5583/5584/5585/5586/5591/5592

XP 5577/5578
LRV DI 5460

2 1 9 1 0 0 1 4 3



2002 Shop Manual Volume 1

GTI, GTI LE, GTX, GTX RFI,
XP, RX, RX DI, LRV DI

BOMBARDIER
RECREATIONAL PRODUCTS



TABLE OF CONTENTS

| SECTION | SUBSECTION | PAGE |
|---|---|---------|
| SAFETY NOTICE | | III |
| INTRODUCTION | | IV |
| 01 SERVICE TOOLS AND PRODUCTS | 01 - Table of contents | 01-01-1 |
| | 02 - Mandatory service tools..... | 01-02-1 |
| | 03 - Optional service tools..... | 01-03-1 |
| | 04 - Service products | 01-04-1 |
| 02 MAINTENANCE | 01 - Table of contents | 02-01-1 |
| | 02 - Periodic inspection chart..... | 02-02-1 |
| | 03 - Flushing and lubrication..... | 02-03-1 |
| | 04 - Water-flooded engine..... | 02-04-1 |
| | 05 - Storage..... | 02-05-1 |
| 03 TROUBLESHOOTING | 01 - Troubleshooting chart | 03-01-1 |
| 04 ENGINE | 01 - Table of contents | 04-01-1 |
| | 02 - Leak test | 04-02-1 |
| | 03 - Removal and installation | 04-03-1 |
| | 04 - Magneto system..... | 04-04-1 |
| | 05 - Top end..... | 04-05-1 |
| | 06 - Bottom end | 04-06-1 |
| | 07 - Rotary valve..... | 04-07-1 |
| | 08 - Exhaust system..... | 04-08-1 |
| 05 ENGINE MANAGEMENT (RFI) | 01 - Table of contents | 05-01-1 |
| | 02 - Overview..... | 05-02-1 |
| | 03 - Diagnostic procedures | 05-03-1 |
| | 04 - Component inspection | 05-04-1 |
| | 05 - Troubleshooting summary | 05-05-1 |
| | 06 - Adjustment..... | 05-06-1 |
| | 07 - Removal and installation | 05-07-1 |
| 06 ENGINE MANAGEMENT (DI) | 01 - Table of contents | 06-01-1 |
| | 02 - Overview..... | 06-02-1 |
| | 03 - Component inspection and adjustment | 06-03-1 |
| | 04 - Diagnostic procedures | 06-04-1 |
| 07 COOLING SYSTEM | 01 - Table of contents | 07-01-1 |
| | 02 - Circuit, components and care | 07-02-1 |
| 08 FUEL SYSTEM | 01 - Table of contents | 08-01-1 |
| | 02 - Fuel circuit..... | 08-02-1 |
| | 03 - Air intake | 08-03-1 |
| | 04 - Carburetor | 08-04-1 |
| 09 LUBRICATION SYSTEM | 01 - Table of contents | 09-01-1 |
| | 02 - Oil injection system..... | 09-02-1 |
| | 03 - Oil injection pump | 09-03-1 |
| 10 ELECTRICAL SYSTEM | 01 - Table of contents | 10-01-1 |
| | 02 - Ignition system..... | 10-02-1 |
| | 03 - Charging system | 10-03-1 |
| | 04 - Starting system..... | 10-04-1 |
| | 05 - Instruments and accessories | 10-05-1 |
| | 06 - Digitally encoded security system (DESS) | 10-06-1 |

TABLE OF CONTENTS

| | | | |
|-----------|----------------------|-------------------------------------|---------|
| 11 | PROPULSION SYSTEM | 01 - Table of contents | 11-01-1 |
| | | 02 - Jet pump..... | 11-02-1 |
| | | 03 - Drive system..... | 11-03-1 |
| | | 04 - Reverse system..... | 11-04-1 |
| | | 05 - Variable trim system..... | 11-05-1 |
| 12 | STEERING SYSTEM | 01 - Table of contents | 12-01-1 |
| | | 02 - Steering system..... | 12-02-1 |
| | | 03 - Alignment | 12-03-1 |
| 13 | SUSPENSION | 01 - Table of contents | 13-01-1 |
| | | 02 - Direct action suspension | 13-02-1 |
| 14 | HULL/BODY | 01 - Table of contents | 14-01-1 |
| | | 02 - Adjustment and repair | 14-02-1 |
| 15 | TECHNICAL DATA | 01 - GTI and GTI LE models..... | 15-01-1 |
| | | 02 - GTX RFI model..... | 15-02-1 |
| | | 03 - XP model | 15-03-1 |
| | | 04 - RX DI model..... | 15-04-1 |
| | | 05 - LRV DI models..... | 15-05-1 |
| | | 06 - GTX and RX models..... | 15-06-1 |
| 16 | WIRING DIAGRAMS | 01 - Wiring diagrams..... | 16-01-1 |

SEA 2000

Shop
Manual
2002

Volume **2**

GTX DI 5563/5564/5595/5596
GTX 4-TEC 5573/5574/5593/5594

2 1 9 1 0 0 1 5 3



2002
Shop Manual
Volume 2

GTX DI, GTX 4-TEC

BOMBARDIER
RECREATIONAL PRODUCTS



TABLE OF CONTENTS

| SECTION | SUBSECTION | PAGE |
|--------------------------------------|--|---------|
| SAFETY NOTICE | | III |
| INTRODUCTION | | IV |
| 01 SERVICE TOOLS AND PRODUCTS | 01 - Table of contents | 01-01-1 |
| | 02 - Mandatory service tools..... | 01-02-1 |
| | 03 - Optional service tools..... | 01-03-1 |
| | 04 - Service products | 01-04-1 |
| 02 MAINTENANCE | 01 - Table of contents | 02-01-1 |
| | 02 - Periodic inspection chart..... | 02-02-1 |
| | 03 - Flushing and lubrication..... | 02-03-1 |
| | 04 - Water-flooded engine..... | 02-04-1 |
| | 05 - Storage..... | 02-05-1 |
| 03 TROUBLESHOOTING | 01 - Troubleshooting chart | 03-01-1 |
| 04 ENGINE (DI) | 01 - Table of contents | 04-01-1 |
| | 02 - Leak test | 04-02-1 |
| | 03 - Removal and installation | 04-03-1 |
| | 04 - Magneto system | 04-04-1 |
| | 05 - Top end | 04-05-1 |
| | 06 - Bottom end | 04-06-1 |
| | 07 - Exhaust system..... | 04-07-1 |
| 05 ENGINE (4-TEC) | 01 - Table of contents | 05-01-1 |
| | 02 - Leak test | 05-02-1 |
| | 03 - Intake system..... | 05-03-1 |
| | 04 - Exhaust system..... | 05-04-1 |
| | 05 - Removal and installation | 05-05-1 |
| | 06 - PTO housing/Magneto | 05-06-1 |
| | 07 - Lubrication..... | 05-07-1 |
| | 08 - Cylinder head and valves..... | 05-08-1 |
| | 09 - Engine block..... | 05-09-1 |
| 06 ENGINE MANAGEMENT (DI) | 01 - Table of contents | 06-01-1 |
| | 02 - Overview..... | 06-02-1 |
| | 03 - Component inspection and adjustment | 06-03-1 |
| | 04 - Diagnostic procedures | 06-04-1 |
| 07 ENGINE MANAGEMENT (4-TEC) | 01 - Table of contents | 07-01-1 |
| | 02 - Overview..... | 07-02-1 |
| | 03 - Component inspection and adjustment | 07-03-1 |
| | 04 - Diagnostic procedures | 07-04-1 |
| 08 COOLING SYSTEM | 01 - Table of contents | 08-01-1 |
| | 02 - Circuit, components and care | 08-02-1 |
| 09 FUEL SYSTEM | 01 - Table of contents | 09-01-1 |
| | 02 - Fuel circuit..... | 09-02-1 |
| | 03 - Air intake (DI)..... | 09-03-1 |
| 10 LUBRICATION SYSTEM (DI) | 01 - Table of contents | 10-01-1 |
| | 02 - Oil injection system..... | 10-02-1 |
| | 03 - Oil injection pump | 10-03-1 |

TABLE OF CONTENTS

| | | | |
|-----------|--------------------------|---------------------------------------|---------|
| 11 | ELECTRICAL SYSTEM | 01 - Table of contents | 11-01-1 |
| | | 02 - Charging system..... | 11-02-1 |
| | | 03 - Starting system..... | 11-03-1 |
| | | 04 - Instruments and accessories..... | 11-04-1 |
| 12 | PROPULSION SYSTEM | 01 - Table of contents | 12-01-1 |
| | | 02 - Jet pump..... | 12-02-1 |
| | | 03 - Drive system..... | 12-03-1 |
| | | 04 - Reverse system..... | 12-04-1 |
| 13 | STEERING SYSTEM | 01 - Table of contents | 13-01-1 |
| | | 02 - Steering system..... | 13-02-1 |
| | | 03 - Alignment | 13-03-1 |
| 14 | HULL/BODY | 01 - Table of contents | 14-01-1 |
| | | 02 - Adjustment and repair | 14-02-1 |
| 15 | TECHNICAL DATA | 01 - GTX DI model | 15-01-1 |
| | | 02 - GTX 4-TEC model | 15-02-1 |
| 16 | WIRING DIAGRAMS | 01 - Wiring diagrams..... | 16-01-1 |

LIST OF ABBREVIATIONS USED IN THIS MANUAL

| | DESCRIPTION |
|----------|--|
| ADC | Analog to Digital Conversion |
| AC | Alternate Current |
| APS | Air Pressure Sensor |
| ATS | Air Temperature Sensor |
| B.U.D.S. | Bombardier Utility and Diagnostic Software |
| CDI | Capacitor Discharge Ignition |
| CPS | Crankshaft Position Sensor |
| CSI | Cooling System Indicator |
| DC | Direct Current |
| DESS | Digitally Encoded Security System |
| DI | Direct Injection |
| E.I.N. | Engine Identification Number |
| ECU | Electronic Control Unit |
| EPA | Environmental Protection Agency (USA) |
| HP | Horse Power |
| LED | Light Emitting Diode |
| MAG | Magneto |
| MPEM | Multi-Purpose Electronic Module |
| MPH | Mile Per Hour |
| MPI | Multi Protocol Interface |
| N.A. | Not Applicable |
| OPT | Optional |
| P/N | Part Number |
| PFD | Personal Flotation Device |
| PSI | Pound Per Square Inch |
| PTO | Power Take Off |
| RAVE | Rotax Adjustable Variable Exhaust |
| RFI | Rotax Fuel Injection |
| RPM | Revolution Per Minute |
| STD | Standard |
| TBD | To Be Determined |
| TDC | Top Dead Center |
| TPS | Throttle Position Sensor |
| VDC | Volt Direct Current |
| VCK | Vehicle Communication Kit |
| VDC | Volt Direct Current |
| VTS | Variable Trim System |
| WTS | Water Temperature Sensor |

GENERAL INFORMATION

The use of RIGHT (starboard) and LEFT (port) indications in the text, always refers to driving position (when sitting on watercraft).

Besides, in the marine industry, FRONT is called BOW and REAR is called STERN.

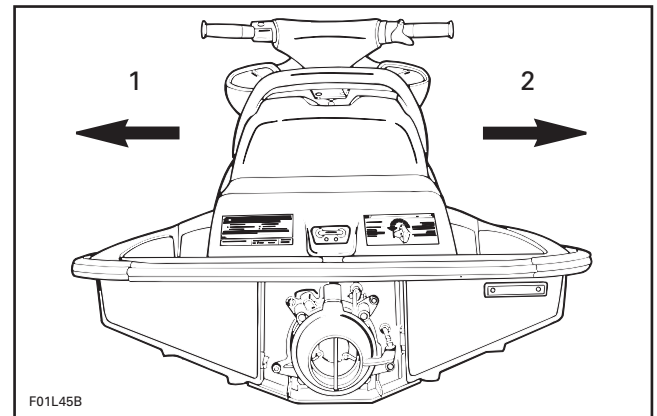

1. Left (port)
2. Right (starboard)

The information and component/system descriptions contained in this manual are correct at time of writing. Bombardier Inc. however, maintains a policy of continuous improvement of its products without imposing upon itself any obligation to install them on products previously manufactured.

Bombardier Inc. reserves the right at any time to discontinue or change specifications, designs, features, models or equipment without incurring obligation.

This *Shop Manual* uses technical terms which may be different from the ones of the *Parts Catalogs*.

When ordering parts always refer to the specific model *Parts Catalogs*.

ILLUSTRATIONS AND PROCEDURES

The illustrations show the typical construction of the different assemblies and, in all cases, may not reproduce the full detail or exact shape of the parts shown, however, they represent parts which have the same or a similar function.

CAUTION: These watercraft are designed with parts dimensioned mostly in the metric system. However some components may be from the imperial system. When replacing fasteners, make sure to use only those recommended by Bombardier.

INTRODUCTION

As many of the procedures in this manual are interrelated, we suggest, that before undertaking any task, you read and thoroughly understand the entire section or subsection in which the procedure is contained.

A number of procedures throughout the book require the use of special tools. Before undertaking any procedure, be sure that you have on hand all the tools required, or approved equivalents.

ENGINE EMISSIONS INFORMATION

Manufacturer's Responsibility

Beginning with 1999 model year engines, PWC manufacturers of marine engines must determine the exhaust emission levels for each engine horsepower family and certify these engines with the United States of America Environmental Protection Agency (EPA). An emissions control information label, showing emission levels and engine specifications, must be placed on each vehicle at the time of manufacture.

Dealer Responsibility

When performing service on all 1999 and more recent Sea-Doo watercrafts that carry an emissions control information label, adjustments must be kept within published factory specifications.

Replacement or repair of any emission related component must be executed in a manner that maintains emission levels within the prescribed certification standards.

Dealers are not to modify the engine in any manner that would alter the horsepower or allow emission levels to exceed their predetermined factory specifications.

Exceptions include manufacturer's prescribed changes, such as altitude adjustments for example.

Owner Responsibility

The owner/operator is required to have engine maintenance performed to maintain emission levels within prescribed certification standards.

The owner/operator is not to, and should not allow anyone to modify the engine in any manner that would alter the horsepower or allow emissions levels to exceed their predetermined factory specifications.

EPA Emission Regulations

All new 1999 and more recent Sea-Doo watercrafts manufactured by Bombardier are certified to the EPA as conforming to the requirements of the regulations for the control of air pollution from new watercraft engines. This certification is contingent on certain adjustments being set to factory standards. For this reason, the factory procedure for servicing the product must be strictly followed and, whenever practicable, returned to the original intent of the design.

The responsibilities listed above are general and in no way a complete listing of the rules and regulations pertaining to the EPA requirements on exhaust emissions for marine products. For more detailed information on this subject, you may contact the following locations:

VIA U.S. POSTAL SERVICE:

Office of Mobile Sources
Engine Programs and Compliance Division
Engine Compliance Programs Group (6403J)
401 M St. NW
Washington, DC 20460

VIA EXPRESS or COURIER MAIL:

Office of Mobile Sources
Engine Programs and Compliance Division
Engine Compliance Programs Group (6403J)
501 3rd St. NW
Washington, DC 20001

EPA INTERNET WEB SITE:

<http://www.epa.gov/omswww>

SELF-LOCKING FASTENERS PROCEDURE

The following describes the most common application procedures when working with self-locking fasteners.

Use a metal brush or a screwtap to clean the hole properly then use a solvent (Methyl-Chloride), let act during 30 minutes and wipe off. The solvent utilization is to ensure the adhesive works properly.

LOCTITE APPLICATION PROCEDURE

The following describes the most common application procedures when working with Loctite products.

NOTE: Always use proper strength Loctite product as recommended in this *Shop Manual*.

THREADLOCKER

Uncovered Holes (bolts and nuts)

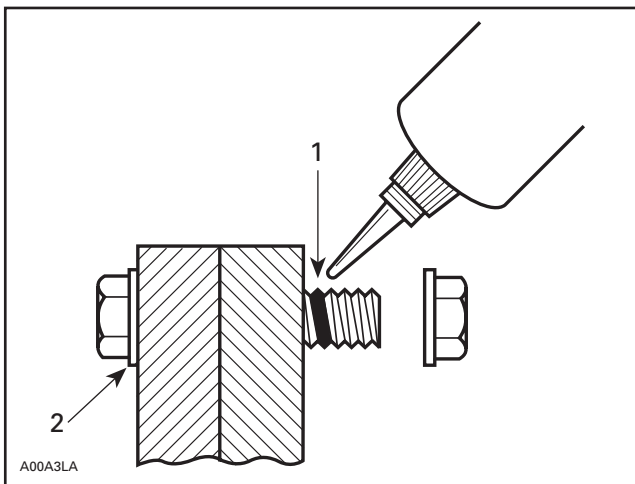

1. Apply here
2. Do not apply

1. Clean threads (bolt and nut) with solvent.
2. Apply Loctite Primer N (P/N 293 800 041) on threads and allow to dry.
3. Choose proper strength Loctite threadlocker.
4. Fit bolt in the hole.
5. Apply a few drops of threadlocker at proposed tightened nut engagement area.
6. Position nut and tighten as required.

Blind Holes

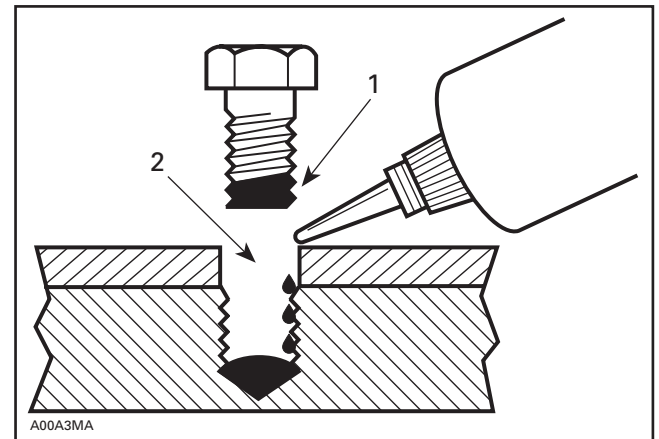

1. On threads
2. On threads and at the bottom of hole

1. Clean threads (bolt and hole) with solvent.
2. Apply Loctite Primer N (P/N 293 800 041) on threads (bolt and nut) and allow to dry for 30 seconds.
3. Choose proper strength Loctite threadlocker.
4. Apply several drops along the threaded hole and at the bottom of the hole.
5. Apply several drops on bolt threads.
6. Tighten as required.

Stud in Blind Holes

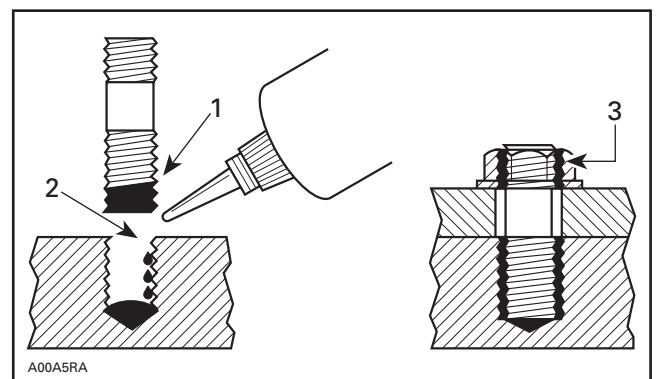

1. On threads
2. On threads and in the hole
3. Onto nut threads

INTRODUCTION

1. Clean threads (stud and hole) with solvent.
2. Apply Loctite Primer N (P/N 293 800 041) on threads and allow to dry.
3. Put several drops of proper strength Loctite threadlocker on female threads and in hole.
4. Apply several drops of proper strength Loctite on stud threads.
5. Install stud.
6. Install cover, etc.
7. Apply drops of proper strength Loctite on uncovered threads.
8. Tighten nuts as required.

Preassembled Parts

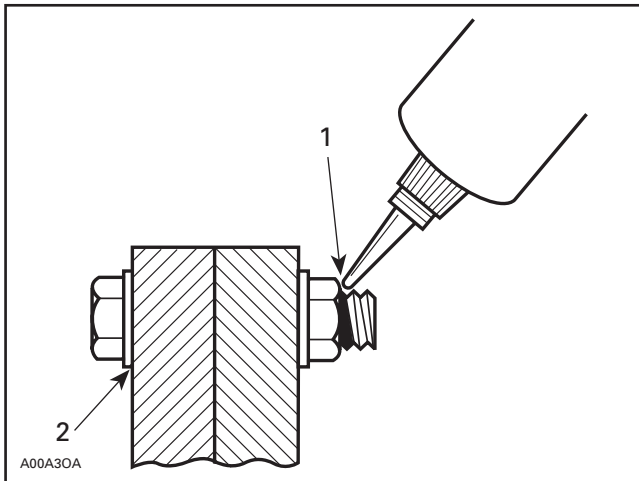

1. Apply here
2. Do not apply

1. Clean bolts and nuts with solvent.
2. Assemble components.
3. Tighten nuts.
4. Apply drops of proper strength Loctite on bolt/nut contact surfaces.
5. Avoid touching metal with tip of flask.

NOTE: For preventive maintenance on existing equipment, retighten nuts and apply proper strength Loctite on bolt/nut contact surfaces.

Adjusting Screw

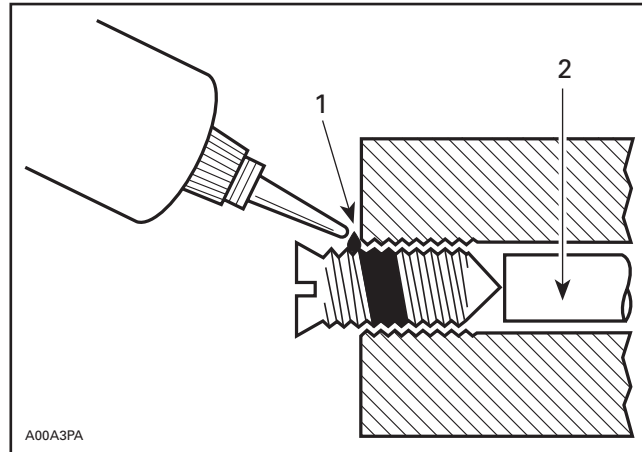

1. Apply here
2. Plunger

1. Adjust screw to proper setting.
2. Apply drops of proper strength Loctite threadlocker on screw/body contact surfaces.
3. Avoid touching metal with tip of flask.

NOTE: If it is difficult to readjust, heat screw with a soldering iron (232°C (450°F)).

STRIPPED THREAD REPAIR

Stripped Threads

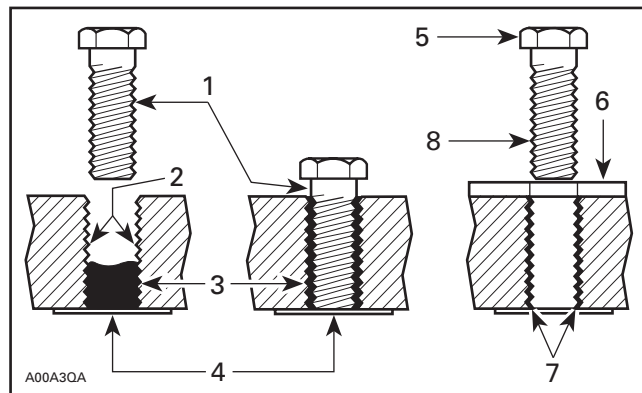

1. Release agent
2. Stripped threads
3. Form-A-Thread
4. Tape
5. Cleaned bolt
6. Plate
7. New threads
8. Threadlocker

Standard Thread Repair

1. Follow instructions on Loctite FORM-A-THREAD 81668 package.
2. If a plate is used to align bolt:
 - a. Apply release agent on mating surfaces.
 - b. Put waxed paper or similar film on the surfaces.
3. Twist bolt when inserting it to improve thread conformation.

NOTE: NOT intended for engine stud repairs.

Repair of Small Holes/Fine Threads

Option 1: Enlarge damaged hole, then follow **Standard Thread Repair** procedure.

Option 2: Apply FORM-A-THREAD on the screw and insert in damaged hole.

Permanent Stud Installation (light duty)

1. Use a stud or thread on desired length.
2. DO NOT apply release agent on stud.
3. Do a **Standard Thread Repair**.
4. Allow to cure for 30 minutes.
5. Assemble.

GASKET COMPOUND

All Parts

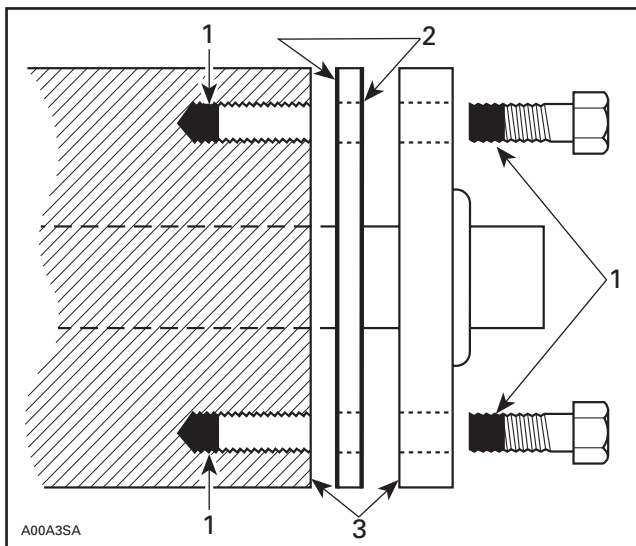

1. Proper strength Loctite
2. Loctite Primer N (P/N 293 800 041) and Gasket Eliminator 518 (P/N 293 800 038) on both sides of gasket
3. Loctite Primer N only

1. Remove old gasket and other contaminants with Loctite Chisel remover (P/N 413 708 500). Use a mechanical mean if necessary.

NOTE: Avoid grinding.

2. Clean both mating surfaces with solvent.
3. Spray Loctite Primer N on both mating surfaces and on both sides of gasket. Allow to dry 1 or 2 minutes.
4. Apply GASKET ELIMINATOR 518 (P/N 293 800 038) on both sides of gasket, using a clean applicator.
5. Place gasket on mating surfaces and assemble immediately.

NOTE: If the cover is bolted to blind holes (above), apply proper strength Loctite in the hole and on threads. Tighten.

If holes are sunken, apply proper strength Loctite on bolt threads.

6. Tighten as usual.

MOUNTING ON SHAFT

Mounting with a Press

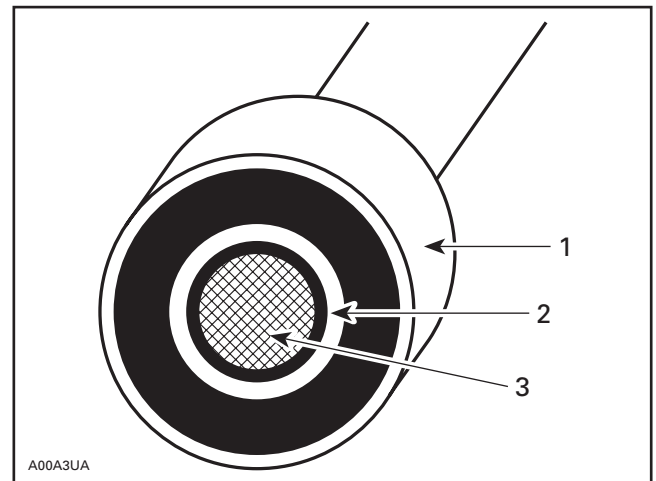

1. Bearing
2. Proper strength Loctite
3. Shaft

Standard

1. Clean shaft external part and element internal part.
2. Apply a strip of proper strength Loctite on shaft circumference at insert or engagement point.

NOTE: Retaining compound is always forced out when applied on shaft.

3. DO NOT use anti-seize Loctite or any similar product.
4. No curing period is required.

INTRODUCTION

Mounting in Tandem

1. Apply retaining compound on internal element bore.
2. Continue to assemble as shown above.

CASE-IN COMPONENTS

Metallic Gaskets

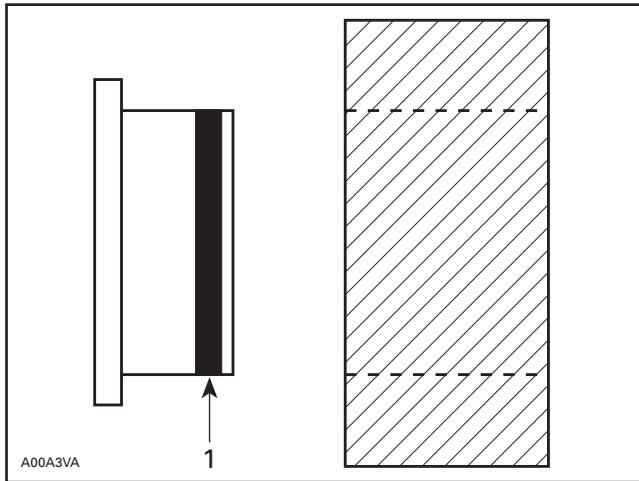

1. Proper strength Loctite

1. Clean inner housing diameter and outer gasket diameter.
2. Spray housing and gasket with Loctite Primer N (P/N 293 800 041).
3. Apply a strip of proper strength Loctite on leading edge of outer metallic gasket diameter.

NOTE: Any Loctite product can be used here. A low strength liquid is recommended as normal strength and gap are required.

4. Install according to standard procedure.
5. Wipe off surplus.
6. Allow it to cure for 30 minutes.

NOTE: Normally used on worn-out housings to prevent leaking or sliding.

It is generally not necessary to remove gasket compound applied on outer gasket diameter.

TIGHTENING TORQUES

Tighten fasteners to torque mentioned in exploded views and text. When they are not specified refer to following table. The table also gives the metric conversion.

| N•m | FASTENER SIZE (8.8) | Lbf•in |
|-----|---------------------|--------|
| 1 | | 9 |
| 2 | M4 | 18 |
| 3 | | 27 |
| 4 | M5 | 35 |
| 5 | | 44 |
| 6 | | 53 |
| 7 | | 62 |
| 8 | | 71 |
| 9 | | 80 |
| 10 | M6 | 89 |
| 11 | | 97 |
| 12 | | 106 |
| 13 | | 115 |
| 14 | | 124 |
| 15 | | 133 |
| 16 | | 142 |
| 17 | | 150 |
| 18 | | 159 |
| 19 | | 168 |

| N•m | FASTENER SIZE (8.8) | Lbf•ft |
|-----|---------------------|--------|
| 20 | | 15 |
| 21 | | 15 |
| 22 | | 16 |
| 23 | M8 | 17 |
| 24 | | 18 |
| 25 | | 18 |
| 26 | | 19 |
| 27 | | 20 |
| 28 | | 21 |
| 29 | | 21 |
| 30 | | 22 |
| 31 | | 23 |
| 32 | | 24 |
| 33 | | 24 |
| 34 | | 25 |
| 35 | | 26 |
| 36 | | 27 |
| 37 | | 27 |

INTRODUCTION

| N•m | FASTENER SIZE (8.8) | Lbf•ft |
|-----|---------------------|--------|
| 38 | | 28 |
| 39 | | 29 |
| 40 | | 30 |
| 41 | | 30 |
| 42 | | 31 |
| 43 | | 32 |
| 44 | | 32 |
| 45 | | 33 |
| 46 | | 34 |
| 47 | | 35 |
| 48 | M10 | 35 |
| 49 | | 36 |
| 50 | | 37 |
| 51 | | 38 |
| 52 | | 38 |
| 53 | | 39 |
| 54 | | 40 |
| 55 | | 41 |
| 56 | | 41 |
| 57 | | 42 |
| 58 | | 43 |
| 59 | | 44 |
| 60 | | 44 |
| 61 | | 45 |
| 62 | | 46 |
| 63 | | 46 |
| 64 | | 47 |
| 65 | | 48 |
| 66 | | 49 |
| 67 | | 49 |
| 68 | | 50 |
| 69 | | 51 |
| 70 | | 52 |
| 71 | | 52 |
| 72 | | 53 |
| 73 | | 54 |
| 74 | | 55 |
| 75 | | 55 |
| 76 | | 56 |
| 77 | | 57 |
| 78 | | 58 |
| 79 | | 58 |
| 80 | M12 | 59 |
| 81 | | 60 |
| 82 | | 60 |

| N•m | FASTENER SIZE (8.8) | Lbf•ft |
|-----|---------------------|--------|
| 83 | | 61 |
| 84 | | 62 |
| 85 | | 63 |
| 86 | | 63 |
| 87 | | 64 |
| 88 | | 65 |
| 89 | | 66 |
| 90 | | 66 |
| 91 | | 67 |
| 92 | | 68 |
| 93 | | 69 |
| 94 | | 69 |
| 95 | | 70 |
| 96 | | 71 |
| 97 | | 72 |
| 98 | | 72 |
| 99 | | 73 |
| 100 | | 74 |
| 101 | | 74 |
| 102 | | 75 |
| 103 | | 76 |
| 104 | | 77 |
| 105 | | 77 |
| 106 | | 78 |
| 107 | | 79 |
| 108 | | 80 |
| 109 | | 80 |
| 110 | | 81 |
| 111 | | 82 |
| 112 | | 83 |
| 113 | | 83 |
| 114 | | 84 |
| 115 | | 85 |
| 116 | | 86 |
| 117 | | 86 |
| 118 | | 87 |
| 119 | | 88 |
| 120 | | 89 |
| 121 | | 89 |
| 122 | | 90 |
| 123 | | 91 |
| 124 | | 91 |
| 125 | | 92 |
| 126 | | 93 |
| 127 | | 94 |

INTRODUCTION

| N•m | FASTENER SIZE (8.8) | Lbf•ft |
|-----|---------------------|--------|
| 128 | | 94 |
| 129 | | 95 |
| 130 | | 96 |
| 131 | | 97 |
| 132 | | 97 |
| 133 | | 98 |
| 134 | | 99 |
| 135 | M14 | 100 |
| 136 | | 100 |
| 137 | | 101 |
| 138 | | 102 |
| 139 | | 103 |
| 140 | | 103 |
| 141 | | 104 |
| 142 | | 105 |
| 143 | | 105 |
| 144 | | 106 |
| 145 | | 107 |
| 146 | | 108 |
| 147 | | 108 |
| 148 | | 109 |
| 149 | | 110 |
| 150 | | 111 |

TIGHTENING TORQUES FOR 8.8 GRADE BOLTS AND NUTS

Technical Publications
Bombardier Inc.
Valcourt (Quebec), Canada

TABLE OF CONTENTS

| | |
|--------------------------------------|----------------|
| MANDATORY SERVICE TOOLS | 01-02-1 |
| ENGINE | 01-02-1 |
| COOLING/FUEL/OIL SYSTEMS | 01-02-4 |
| PROPULSION SYSTEM..... | 01-02-5 |

| | |
|-------------------------------------|----------------|
| OPTIONAL SERVICE TOOLS | 01-03-1 |
| ENGINE | 01-03-1 |
| COOLING/FUEL/OIL SYSTEMS | 01-03-4 |
| PROPULSION SYSTEM..... | 01-03-5 |
| WATERCRAFT HANDLING..... | 01-03-6 |

| | |
|-------------------------------|----------------|
| SERVICE PRODUCTS | 01-04-1 |
|-------------------------------|----------------|

MANDATORY SERVICE TOOLS

ENGINE

Degree wheel
P/N 529 035 607

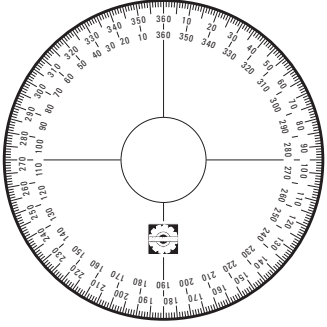

A00B334

APPLICATION
717 and 787 engines.

Piston circlip installer
A) P/N 529 035 562
B) P/N 529 035 563



F06B014

APPLICATION
A) 717 and 787 engines.
B) 947 and 947 DI engines.

Sleeve set
A) P/N 529 035 542
(20 mm sleeve)
B) P/N 529 035 543
(21 mm sleeve)

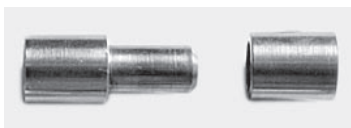

F00B0U4

APPLICATION
A) 717 and 787 engines.
B) 947 and 947 DI engines.

Air compressor ring compressor
P/N 529 035 713



F12B0L4

APPLICATION
947 DI engine.

Carbon dam guide
P/N 529 035 715



F12B0M4

APPLICATION
947 DI engine.

Carbon dam compressor
P/N 529 035 716

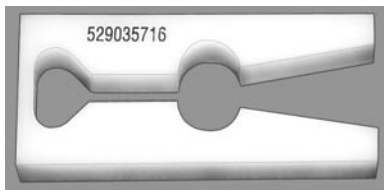

529035716

F12B0N4

APPLICATION
947 DI engine.

Bearing pusher
P/N 420 876 501



F00B074

APPLICATION
717 and 787 engines.

PTO flywheel remover/installer
P/N 295 000 001

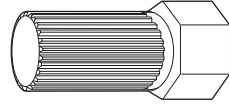

F01J0T4

APPLICATION
717 engine.
NOTE: This tool is also used for the impeller.

Starter drive bearing pusher
P/N 290 876 502

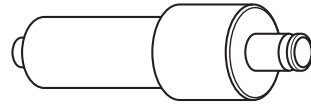

F06B054

APPLICATION
947 and 947 DI engines.

Piston pin puller
P/N 529 035 503
Expansion sleeve
P/N 295 000 117 (787 engine)



F00B0T4

APPLICATION
All engines.

Section 01 SERVICE TOOLS AND PRODUCTS

Subsection 02 (MANDATORY SERVICE TOOLS)

Puller
P/N 529 035 547

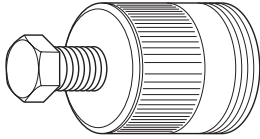

A00C1A4

Puller plate
P/N 420 876 080

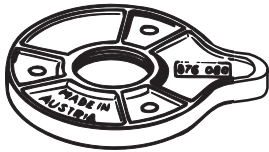

A00C1R4

Extension handle
P/N 295 000 125



F01D164

Screw M8 x 35 (3)
P/N 420 841 591



F00A094

Sleeve (3)
P/N 290 847 220



F00A0A4

APPLICATION

717 engine.

Puller is also used for PTO flywheel on 947 and 947 DI engines.

Pusher
P/N 420 876 605

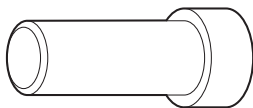

A00C0Y4

APPLICATION

717 engine.

Puller ass'y
P/N 290 876 488
1) Screw P/N 290 240 860
2) Hexagonal nut P/N 290 242 210

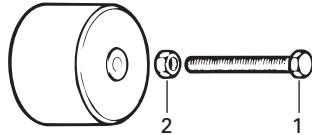

F01B014

APPLICATION

717 and 787 engines.

Alignment support plate kit
P/N 529 035 506

- 1) Alignment plates
A) P/N 529 035 507
B) P/N 529 035 508
- 2) Support
P/N 529 035 511
- 3) Screw (2)
P/N 207 182 544
- 4) Lock washer (2)
P/N 234 181 601
- 5) Flat washer (2)
P/N 234 081 410

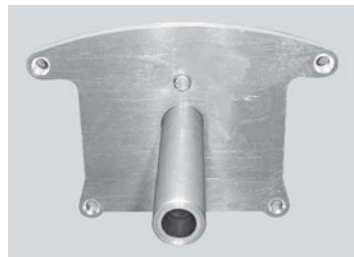

F00B0F4

APPLICATION

All models.

- A) 155.6 mm jet pump.
- B) 139.5 mm jet pump.

Alignment shaft
P/N 295 000 141



F00B0G4

APPLICATION

All models.

Adapter
P/N 529 035 590

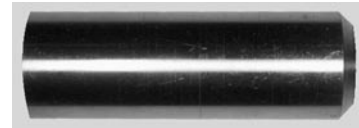

F00B124

APPLICATION

XP model.

VCK (Vehicle Communication Kit)
P/N 529 035 676



F12H0A4

APPLICATION

All models.

Flywheel extractor
P/N 295 000 156

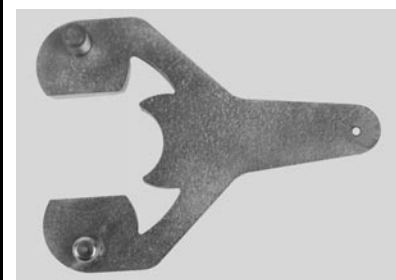

F00B044

APPLICATION

XP model.

Section 01 SERVICE TOOLS AND PRODUCTS

Subsection 02 (MANDATORY SERVICE TOOLS)

Engine leak tester kit
P/N 295 500 352
Pump only
P/N 529 021 800

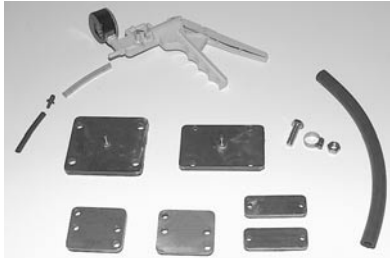

F01B2Q5

APPLICATION

717, 787, 947 and 947 DI engines.

Supplementary engine leak test kit

P/N 295 500 780

- 1) 787 RFI Intake plate
P/N 296 000 024
- 2) 947 Intake plate
P/N 296 000 025
- 3) 947 Rave plate
P/N 296 000 026
- 4) 947 Exhaust plate
P/N 296 000 027

APPLICATION

787 RFI and 947 engines.

NOTE: This kit is supplementary to P/N 295 500 352.

Handle
P/N 420 877 650

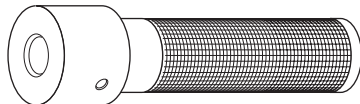

A00C3V4

APPLICATION

Use with pushers (P/N 290 876 609 and 290 877 740).

Ring gear puller tool
P/N 420 976 235 (puller ass'y)
P/N 529 035 549 (puller bolt)



F01B294

APPLICATION

787, 947 and 947 DI engines.

Crankshaft protective cap

- A) P/N 420 876 557
- B) P/N 290 877 414



F00B194

APPLICATION

A) 717 and 787 engines.

B) 947 and 947 DI engines.

Polygonal wrench
P/N 529 035 505

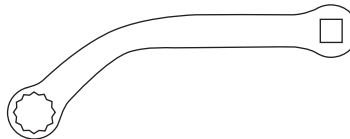

F00B0Y4

APPLICATION

Exhaust system of the 947 and 947 DI engines.

Ring gear blocking tool kit
P/N 529 035 846



F15B014

APPLICATION

787 engine.

Rotary valve shaft pusher
P/N 290 876 609

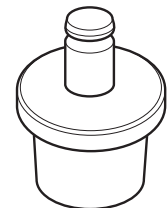

F01B2B4

APPLICATION

787 engine.

Oil seal pusher
P/N 290 877 740

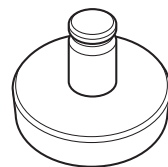

F01B2C4

APPLICATION

787 engine.

Intake plug
P/N 529 035 708

APPLICATION

947 DI engine.

Section 01 SERVICE TOOLS AND PRODUCTS

Subsection 02 (MANDATORY SERVICE TOOLS)

COOLING/FUEL/OIL SYSTEMS

Gear holder
P/N 420 277 905

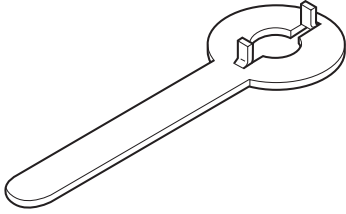

A00C164

APPLICATION

717 engine.

Pliers
P/N 295 000 070

Oetiker 1099

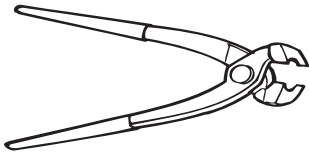

F01D174

APPLICATION

All models.

Pliers
P/N 295 000 054

Caillau

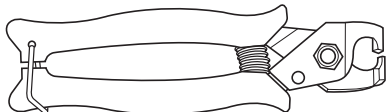

F01B1T4

APPLICATION

All models.

NOTE: This tool is also used for the propulsion system.

Fuel pressure gauge
P/N 529 035 591



F02B0B4

APPLICATION

787 RFI engine.

Fuel line disconnect tool
P/N 529 035 714

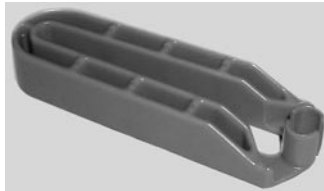

F12B0G4

APPLICATION

947 DI engine.

1. Fuel pressure gauge
P/N 529 035 709
2. Fuel pressure gauge T-fitting
P/N 529 035 710
3. Fuel pressure gauge pressure relief valve
P/N 529 035 711
4. Fuel pressure gauge air compressor adapter
P/N 529 035 712

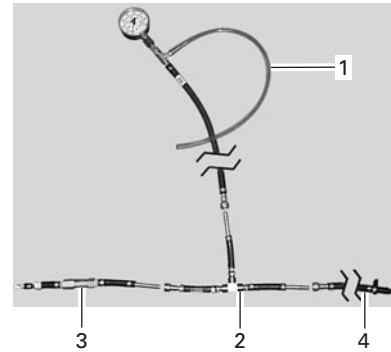

F12R014

APPLICATION

947 DI engine.

Section 01 SERVICE TOOLS AND PRODUCTS

Subsection 02 (MANDATORY SERVICE TOOLS)

PROPULSION SYSTEM

Impeller remover/installer
P/N 295 000 001

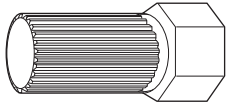

F01J0T4

APPLICATION

All models.

NOTE: This tool is also used for the PTO flywheel (on some models).

Bearing/seal installer
P/N 295 000 107

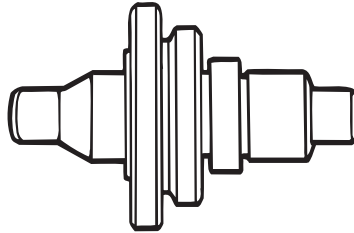

F01J4K4

APPLICATION

All models except GTX and XP.

Pliers
P/N 295 000 054

Caillau

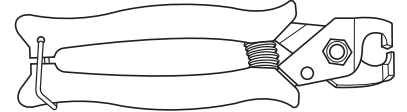

F01B1T4

APPLICATION

All models.

NOTE: This tool is also used for the fuel system.

Pliers
P/N 295 000 069

Oetiker 1090

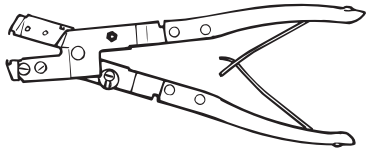

F01D184

APPLICATION

All models.

Inner seal installer
P/N 529 035 609



F08B014

APPLICATION

155.6 mm (6-1/8 in) jet pump.

VTS tool
P/N 295 000 133

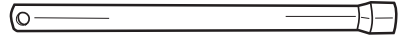

F01B2P4

APPLICATION

XP models.

Impeller shaft holder
P/N 295 000 082

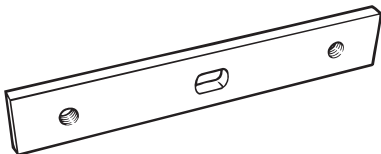

F01B0W4

APPLICATION

All models.

Drive shaft alignment tool
P/N 529 035 590



F08B024

APPLICATION

XP model.

Jet pump bearing remover
P/N 295 000 144



F01J114

APPLICATION

All models.

Impeller shaft guide
P/N 295 000 002

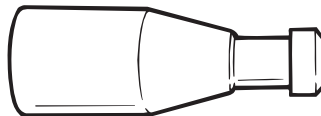

F01J104

APPLICATION

All models.

Section 01 SERVICE TOOLS AND PRODUCTS

Subsection 02 (MANDATORY SERVICE TOOLS)

NEW

OPAS cylinder nut wrench
P/N 529 035 840



F18B0A4

APPLICATION
GTI LE.

OPTIONAL SERVICE TOOLS

ENGINE

Coil centering tool
P/N 420 876 922

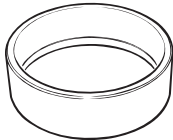

A01B1V4

APPLICATION
717 engine.

Cylinder aligning tool
P/N 420 876 904



A00B084

APPLICATION
717 engine.

Distance gauge

- A) P/N 529 034 800, 14 mm (.551 in)
- B) P/N 529 034 900, 15.4 mm (.606 in)
- C) P/N 529 035 100, 11.5 mm (.453 in)
- D) P/N 529 035 000, 7.5 mm (.295 in)

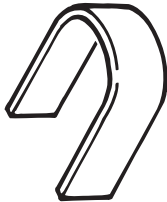

F01B0H4

APPLICATION
A) 717 engine.
B) 787 engine.
C) 947 and 947 DI engines (MAG).
D) 947 and 947 DI engines (PTO).

Stroboscopic timing light
P/N 529 031 900



A00B4F4

APPLICATION
All models.

- A) Four-pin magneto harness
P/N 295 000 131
- B) Six-pin magneto harness
P/N 295 000 136



F01B284

APPLICATION
A) 717 engine.
B) 787, 947 and 947 DI engines.

Dial indicator (TDC gauge)
P/N 295 000 143

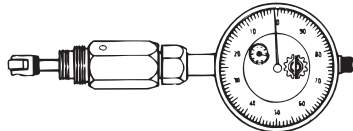

A00B4E4

APPLICATION
All models.

Digital/induction type tachometer
P/N 529 014 500

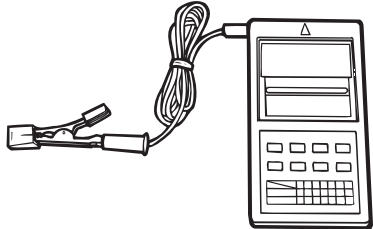

F01B1G4

APPLICATION
All models.

Timing mark pointer
P/N 295 000 130

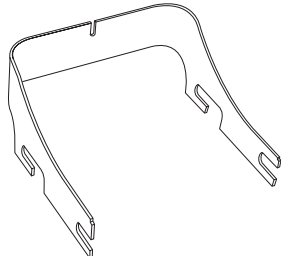

F01B2O4

APPLICATION
717 engine.

Timing mark pointer
P/N 295 000 135



F01H544

APPLICATION
787, 947 and 947 DI engines.

Section 01 SERVICE TOOLS AND PRODUCTS

Subsection 03 (OPTIONAL SERVICE TOOLS)

Crimping tool
P/N 295 100 164



F00B0E4

APPLICATION

Contacts of AMP plug connectors.

Terminal (Packard) remover
Not sold by Bombardier

Snap-on
TT 600-4

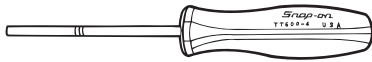

F01B1J4

APPLICATION

All models.

Joint connector tool
Not sold by Bombardier

Deutsch
114010



F12B0C4

APPLICATION

DI models.

Safety lanyard switch tool
P/N 529 034 600



F01B244

APPLICATION

All models.

Slide hammer puller
Not sold by Bombardier

Snap-on:
Handle: CJ93-1
Hammer: CJ125-6
Claws: CJ93-4

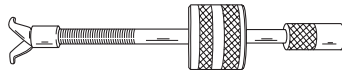

F01J0Z4

APPLICATION

717 and 787 engines.

NOTE: This tool is also used to pull out impeller shaft seal.

Protective mat
P/N 295 000 128



F02B0A4

APPLICATION

All models.

Gear/bearing puller
P/N 290 877 665

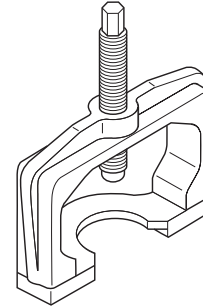

F04B034

APPLICATION

787 engine.

Exhaust outlet tool
P/N 295 000 132

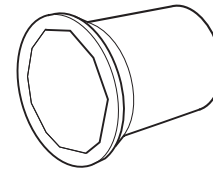

F01B2A4

APPLICATION

All models.

Engine lifting device

Not sold by Bombardier

Do it yourself

Refer to REMOVAL AND INSTALLATION section of engine.



F01D0A4

APPLICATION

717 engine and DI models.

Section 01 SERVICE TOOLS AND PRODUCTS

Subsection 03 (OPTIONAL SERVICE TOOLS)

Feeler gauge 45°
Not sold by Bombardier

Snap-on
FB 300 A

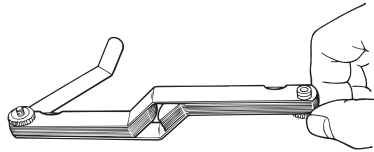

F01B1K4

APPLICATION

717 and 787 engines.

MPEM programmer
P/N 529 035 878



A01B5B4

APPLICATION

All models.

Steering cable tool
P/N 295 000 145

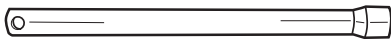

F01B2P4

APPLICATION

All models.

Rubber pad
P/N 295 000 101

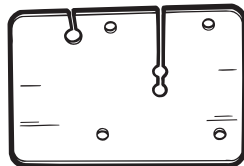

F01B0J4

APPLICATION

717 and 787 engines.

Rubber pad
P/N 290 877 032

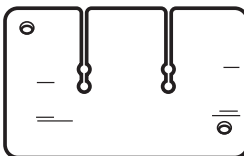

F06B064

APPLICATION

947 and 947 DI engines.

Piston ring compressor (2)
A) P/N 290 876 965 (88 mm)
B) P/N 290 876 979 (82 mm)

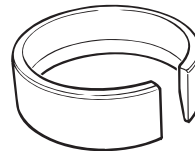

F01B1T4

APPLICATION

A) 947 and 947 DI engines.
B) 717 and 787 engines.

Digital multimeter
P/N 529 035 868



APPLICATION

All models.

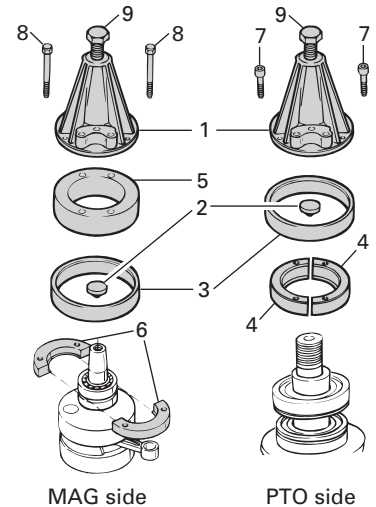

MAG side

PTO side

F01D885

- 1) Puller ass'y
P/N 420 877 635
- 2) Protective cap
P/N 420 876 557
P/N 290 877 414 (947 and 947 DI engines)
- 3) Ring (both ends)
P/N 420 977 490
P/N 420 977 480 (947 and 947 DI engines)
- 4) Ring halves (PTO)
P/N 420 977 475 (2)
P/N 420 876 330 (947 and 947 DI engines)
- 5) Distance ring (MAG)
P/N 420 876 569
- 6) Ring halves (MAG)
P/N 420 276 025 (2)
- 7) Screw M8 x 40
P/N 420 840 681 (2)
- 8) Screw M8 x 70
P/N 420 841 201 (2)
- 9) Puller bolt
P/N 420 940 755

APPLICATION

All engines.

Section 01 SERVICE TOOLS AND PRODUCTS

Subsection 03 (OPTIONAL SERVICE TOOLS)

COOLING/FUEL/OIL SYSTEMS

Pump gauge tester
P/N 295 000 114

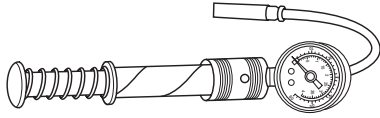

F01B0X4

APPLICATION

All models except RFI and DI models.

Lighted adjustable mirror
Not sold by Bombardier

Snap-on
50101



F01B114

APPLICATION

All models.

Hose pincher
P/N 529 032 500

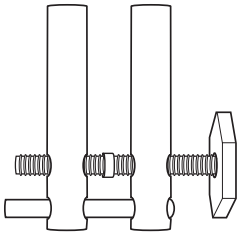

F01B234

APPLICATION

All models.

Spring compressor
P/N 529 035 504

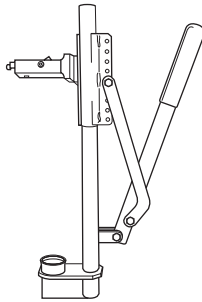

A01B404

APPLICATION

XP model.

Suspension adjustment wrench
P/N 529 012 200

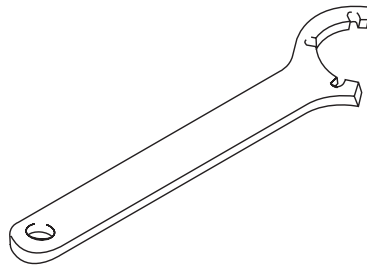

A25A014

APPLICATION

XP model.

Flexible spout (oil)
P/N 414 837 300

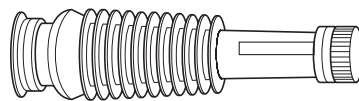

F04B044

APPLICATION

All models.

Flushing adapter
P/N 295 500 473



F00B104

APPLICATION

All models.
Use with coupler hose (P/N 295 500 258).

Hose pincher
P/N 295 000 076

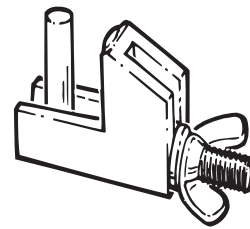

A01B214

APPLICATION

All models.

PROPULSION SYSTEM

Fitting
P/N 295 000 086

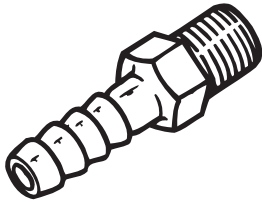

F01B0Z4

APPLICATION

All models.

Slide hammer puller
Not sold by Bombardier

Snap-on:
Handle: CJ93-1
Hammer: CJ125-6
Claws: CJ93-4

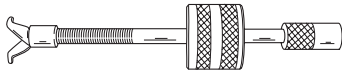

F01J0Z4

APPLICATION

All models.

NOTE: This tool is also used to remove rotary valve shaft bearing.

Hacksaw
Not sold by Bombardier

Snap-on
HS3



F01B1M4

APPLICATION

All models.

Section 01 SERVICE TOOLS AND PRODUCTS

Subsection 03 (OPTIONAL SERVICE TOOLS)

WATERCRAFT HANDLING

Dolly (with wheels)
P/N 295 000 126

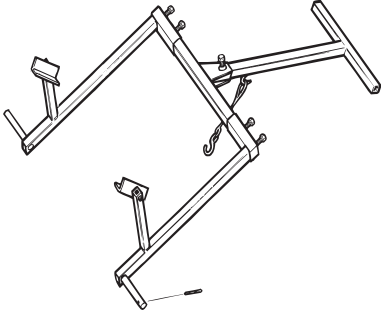

F01B014

Beach wheels (set of 2 wheels)
P/N 295 000 005

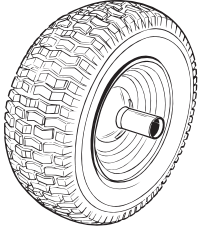

F01B074

APPLICATION
Dolly.

Tie-down with ratchet
3.60 m (12 ft) long
P/N 295 100 104

APPLICATION

All models.

Tie-down
1.50 m (5 ft) long
P/N 295 100 103

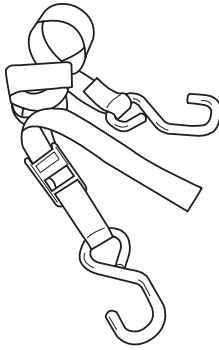

F00B014

APPLICATION

All models.



Download the full PDF manual instantly.

Our customer service e-mail:

aservicemanualpdf@yahoo.com