

**Official**

# **HONDA**

## **SHOP MANUAL ATC70**



**'73—'84**

## IMPORTANT SAFETY NOTICE

**WARNING**

*Indicates a strong possibility of severe personal injury or loss of life if instructions are not followed.*

**CAUTION**

*Indicates a possibility of personal injury or equipment damage if instructions are not followed.*

Detailed descriptions of standard workshop procedures, safety principles and service operations are not included. It is important to note that this manual contains *some* warnings and cautions against some specific service methods which could cause **PERSONAL INJURY** to service personnel or could damage a vehicle or render it unsafe. Please understand that those warnings could not cover all conceivable ways in which service, whether or not recommended by Honda might be done or of the possibly hazardous consequences of each conceivable way, nor could Honda investigate all such ways. Anyone using service procedures or tools, whether or not recommended by Honda *must satisfy himself thoroughly* that neither personal safety nor vehicle safety will be jeopardized by the service method or tools selected.



# HONDA ATC70

## HOW TO USE THIS MANUAL

This shop manual describes the technical features and servicing procedures for the Honda ATC70. Since this model uses the same basic engine as the CT70, this shop manual should be used with the ST50•70/CT70•70H manuals for complete information and procedures.

Refer to the Addendums beginning on page 35 for servicing of 1978 and later ATC70's. Note that addendums were not issued between 1979 and 1981.

ALL INFORMATION, ILLUSTRATIONS, DIRECTIONS AND SPECIFICATIONS INCLUDED IN THIS PUBLICATION ARE BASED ON THE LATEST PRODUCT INFORMATION AVAILABLE AT THE TIME OF APPROVAL FOR PRINTING. HONDA MOTOR CO., LTD. RESERVES THE RIGHT TO MAKE CHANGES AT ANY TIME WITHOUT NOTICE AND WITHOUT INCURRING ANY OBLIGATION WHATEVER.

NO PART OF THIS PUBLICATION MAY BE REPRODUCED WITHOUT WRITTEN PERMISSION.

HONDA MOTOR CO., LTD.  
Service Publications Office

## CONTENTS

I. SERVICE PRECAUTIONS . . . . .	1
II. INSPECTION AND ADJUSTMENT . . . . .	2
1. Tappet . . . . .	2
2. Contact breaker point gap and ignition timing. . . . .	3
3. Carburetor . . . . .	3
4. Clutch . . . . .	3
5. Cam chain . . . . .	4
6. Engine oil . . . . .	4
7. Brake . . . . .	5
8. Air cleaner . . . . .	5
9. Drive chain. . . . .	6
10. Drive chain lubrication . . . . .	6
11. Spark plug . . . . .	6
12. Throttle cable. . . . .	7
13. Fuel filter . . . . .	7
III. ENGINE . . . . .	8
1. Engine removal and installation . . . . .	8
2. Major difference between ATC70 and CT70 engines . . . . .	9
IV. FRAME. . . . .	10
1. Front wheel . . . . .	10
2. Rear wheel and brake. . . . .	13
3. Handlebar . . . . .	19
4. Front fork . . . . .	21
5. Frame body . . . . .	22
V. SERVICE DATA. . . . .	24
1. Special tools . . . . .	24
2. Wiring diagram . . . . .	24
3. Maintenance schedule. . . . .	25
4. Torque specifications . . . . .	26
5. Service data . . . . .	27
6. Troubleshooting . . . . .	28
7. Specifications . . . . .	30
VI. MAJOR MODIFIED POINTS OF ATC70K1. . . . .	32
1978 ADDENDUM . . . . .	35
1982 ADDENDUM . . . . .	47
1983—1984 ADDENDUM . . . . .	61

**I. SERVICE PRECAUTIONS**

1. Always use new gaskets, O-rings and cotter pins whenever reassembling.
2. When tightening bolts or nuts for which sequence is not specified, begin on center or larger diameter bolts, and tighten them in a criss-cross pattern to specified torque in two or more steps if necessary.
3. Use genuine HONDA PARTS and LUBRICANTS or those recommended by HONDA.
4. Use special service tool where use of such a tool is specified.
5. Clean engine parts in or with cleaning solvent upon disassembly. Apply lubricant to their sliding surfaces when reassembling.
6. Coat or fill parts with grease where specified as such.
7. Upon assembling, check every possible part for proper installation and movement or operation.
8. When working with others, try to give a signal or communicate for safety.

**NOTES :**

1. The procedures for reassembling the engine and frame parts are not described when these are performed by reversing the disassembling procedures.
2. All the service data for each component are compiled on the last pages of this manual.



## II. INSPECTION AND ADJUSTMENT

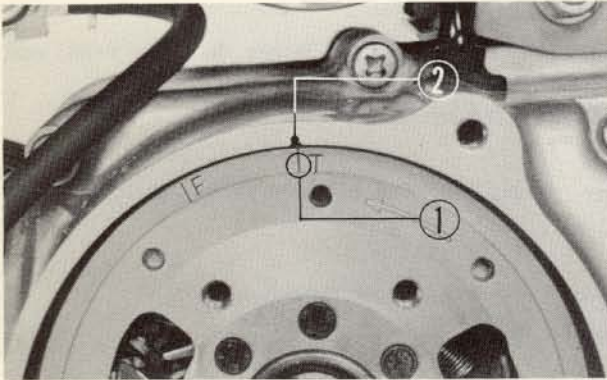

**Fig. 2-1**  
 ① "T" mark      ② Index mark

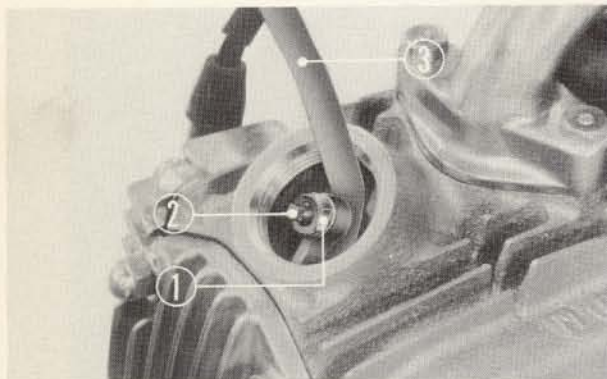

**Fig. 2-2**  
 ① Adjusting screw lock nut      ③ Feeler gauge  
 ② Adjusting screw

The services set forth in this section are those which are important of all listed in the MAINTENANCE SCHEDULE on page 25. Those not listed in the Schedule are covered in procedures under "INSPECTION" in each section.

### 1. TAPPET

The tappet clearance adjustment should be made while the engine is cold.

1. Remove the recoil starter and tappet adjusting hole caps.
2. Rotate the generator rotor counterclockwise until the mark "T" on the rotor aligns with the index mark on the stator.

In this position, the piston may either be on the compression or the exhaust stroke. The adjustment must be made when the piston is at the top dead center on its compression stroke when the intake and exhaust valves are closed.

This can be determined by moving the tappets with the fingers. If the tappets are free, it is an indication that the valves are closed and that the piston is on the compression stroke.

If the tappets are tight and the valves are open, rotate the generator rotor 360° and realign the "T" mark with the index mark.

3. Check the clearance of both valves by inserting the 0.05 mm (0.002 in.) gauge between the valve stem and the adjusting screw.

To adjust, loosen the adjusting screw lock nut and turn the adjusting screw either in or out to allow the gauge to pass through the clearance with slight resistance.

4. After completing the adjustment, tighten the lock nut firmly to secure the adjustment. Recheck the clearance to make sure that the adjustment has not been disturbed.

5. Install the tappet adjusting hole caps and recoil starter.

## 2. CONTACT BREAKER POINT GAP AND IGNITION TIMING

Ignition timing is adjusted by altering the contact breaker point gap.

1. Remove the recoil starter located on the left side of the engine.
2. Rotate the generator rotor counterclockwise until the mark "F" aligns with the index mark. Ignition timing is correct if the contact breaker points begins to open as the marks align.
3. If ignition timing is incorrect, loosen the contact breaker locking screw and adjust the gap to specification. Increasing the gap will advance timing. Decreasing the gap will retard the timing.
4. Retighten the contact breaker locking screw and recheck the ignition timing.

### NOTE:

Point gap must remain within limits of 0.3 to 0.4 mm (0.012 to 0.016 in.) after ignition timing has been set. If correct timing results in a point gap which is outside these limits, replace the breaker points.

## 3. CARBURETOR

The carburetor should be adjusted with the engine at operating temperature and the choke fully open.

1. Turn in the idle screw until the engine idles at approximately 1,500 rpm. Turn the idle screw in to increase engine speed and out to decrease engine speed.
2. Turn the air screw in until you hear engine missing or engine rpm begins to drop; then, turn it out until the engine again misses or decreases in speed.

Set the air screw midway between these two extreme positions. Turn this screw in to make the mixture richer or out to make it leaner. Correct setting will be usually obtained when the screw is turned out  $\frac{7}{8}$  to  $1\frac{1}{2}$  turns from its fully closed position.

3. If the idle speed changes after adjusting the mixture, readjust the idle screw as required.

## 4. CLUTCH

The automatic clutch should be adjusted with the engine stopped.

1. Remove the clutch adjuster rubber cap.
2. Loosen the lock nut and turn out the clutch adjuster until resistance is felt; turn in the adjuster  $\frac{1}{8}$  to  $\frac{1}{4}$  turn. Tighten the lock nut firmly to secure the adjustment.
3. After adjustment, start the engine and test ride the ATC70 to be sure that the clutch is operating properly.

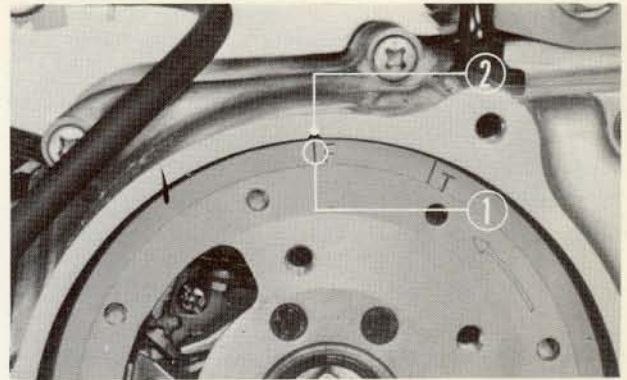

Fig. 2-3

① "F" mark      ② Index mark

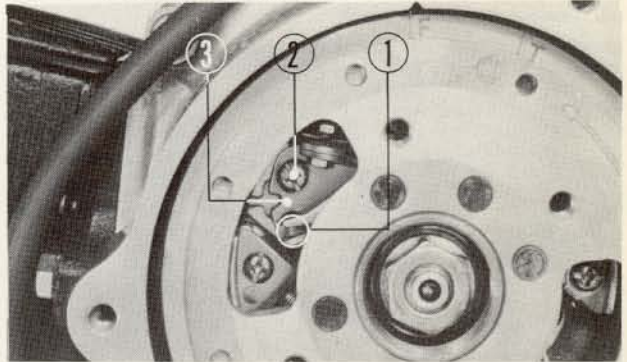

Fig. 2-4

① Contact breaker point      ③ Contact breaker point base  
 ② Contact breaker locking screw

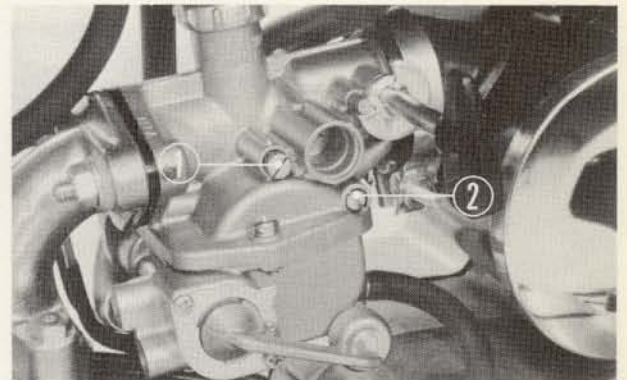

Fig. 2-5

① Idle screw      ② Air screw

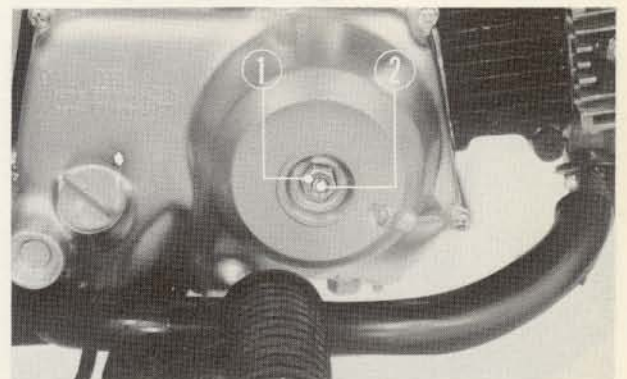

Fig. 2-6

① Lock nut      ② Clutch adjuster

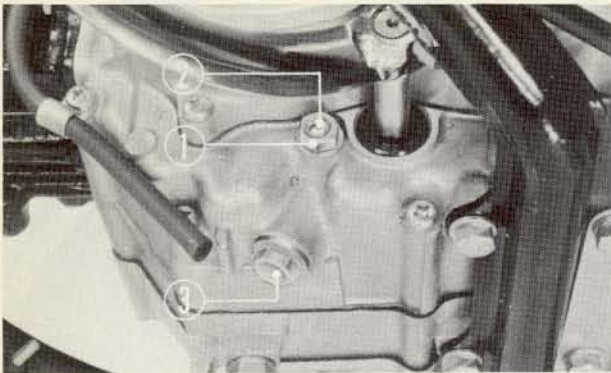

Fig. 2-7

- ① Lock nut
- ② Tensioner adjusting bolt
- ③ Sealing bolt

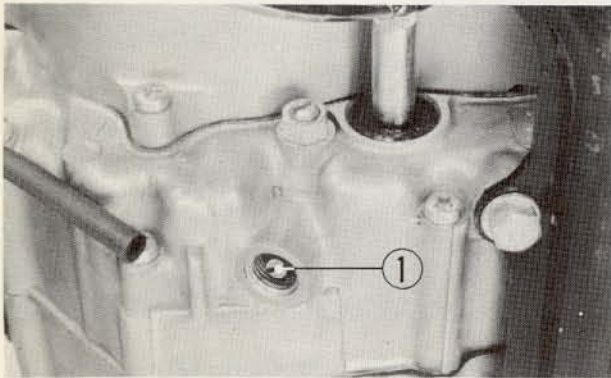

Fig. 2-8

- ① Tensioner bolt

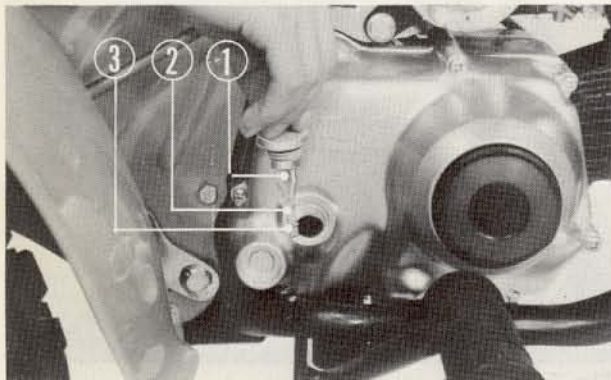

Fig. 2-9

- ① Dipstick
- ② Upper level mark
- ③ Lower level mark

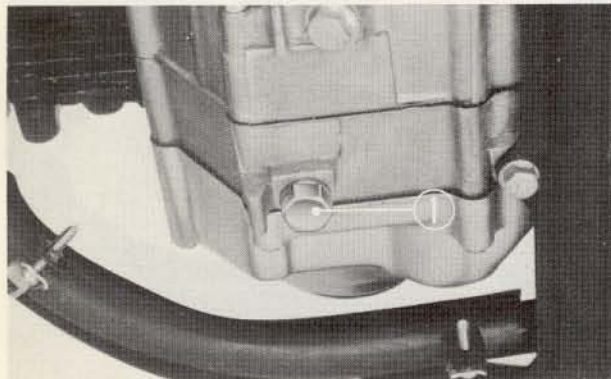

Fig. 2-10

- ① Drain plug

## 5. CAM CHAIN

Tension adjustment should be made while the engine is running at idle speed, if unusual noise is heard.

1. To adjust, with the lock nut loosened, turn out the tensioner adjusting bolt approximately one-half turn.
  
2. If the chain is still noisy even after the above adjustment, loosen off the 14 mm sealing bolt, and screw in the tensioner bolt gradually until noise is minimized. The sealing bolt will be found on the left bottom side of the engine crankcase.
  
3. After completing the adjustment, tighten the tension adjusting bolt, lock nut, and 14 mm sealing bolt securely.

## 6. ENGINE OIL

### Oil level check

1. Place the ATC70 on a level ground.
2. Insert the oil level gauge into the oil filler hole to check the oil level. (Do not screw it in.)  
Oil level should be anywhere between the upper and lower level marks on the dipstick.
3. If necessary, refill the crankcase with specified oil.

API classification : SE

Specified viscosity :

In all seasons                      SAE 10W-40 or SAE 10W-30

Above 15°C (59°F)	SAE 30
0°-15°C (32°-59°F)	SAE 20 or 20W
Below 0°C (32°F)	SAE 10W

### Oil change

1. Remove the oil filler cap from the right crankcase cover.
2. Place a drip pan under the engine to catch the oil, and then remove the drain plug.
3. After the oil stops draining from the crankcase, operate the recoil starter rope several times to drain any oil which may be left in the engine.
4. When the oil has been completely drained, reinstall the drain plug. Be sure the washer which seals the drain plug is in good condition.
5. Fill the crankcase through the oil filler opening with approximately 0.8 liter (0.8 U.S. qt.) of specified grade of motor oil. Make sure that the oil level is up to the upper level mark. If the level is low, add oil.

7. BRAKE

1. Correct free play is 15 to 20 mm (0.6 to 0.8 in.) as measured at the tip of the brake lever.
2. Free play can be adjusted by turning the adjusting nut on the brake rod. Turn this nut in direction A to decrease the play and in direction B to increase it.

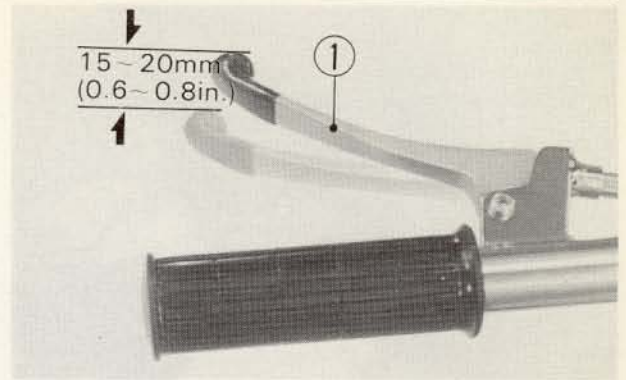

Fig. 2-11  
① Brake lever

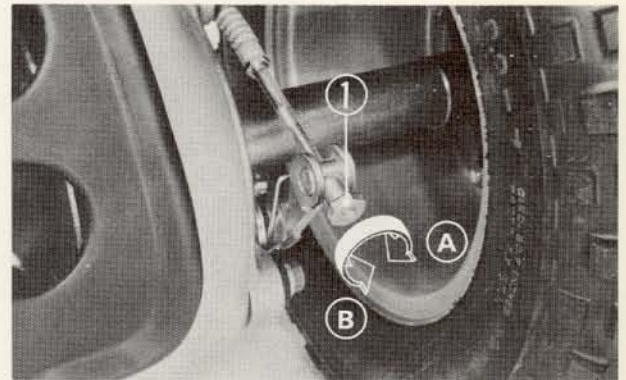

Fig. 2-12  
① Brake adjusting nut

8. AIR CLEANER

1. Remove the cap bolt and take out the cover from the case together with the gasket.
2. Pull out the element from the case; separate the set plate and inner pipe from the element.
3. Wash the element in clean stoddard solvent and allow to dry thoroughly.
4. Soak the element in clean gear oil (SAE 80-90) until saturated, then squeeze out excess oil.
5. Assemble the cleaner in the reverse order of the disassembly.

**WARNING:**  
Gasoline or low flash point solvents are highly flammable and must not be used to clean the element.

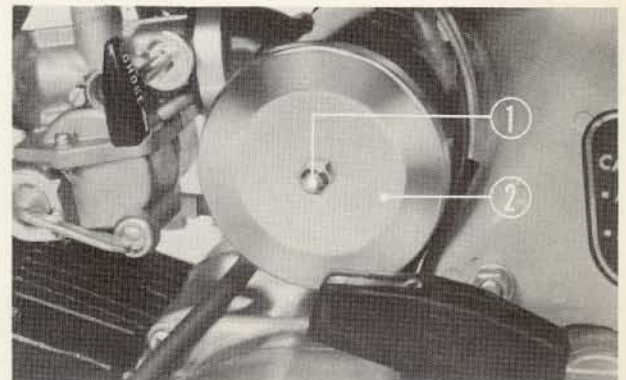

Fig. 2-13  
① Nut ② Air cleaner cover



Fig. 2-14  
① Filter element ② Set plate ③ Inner pipe



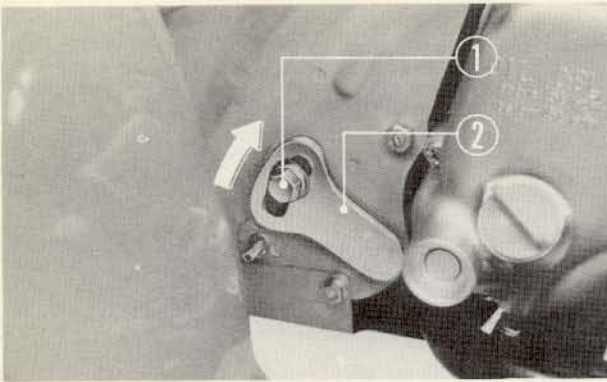

Fig. 2-15

① Lock bolt    ② Tensioner shaft

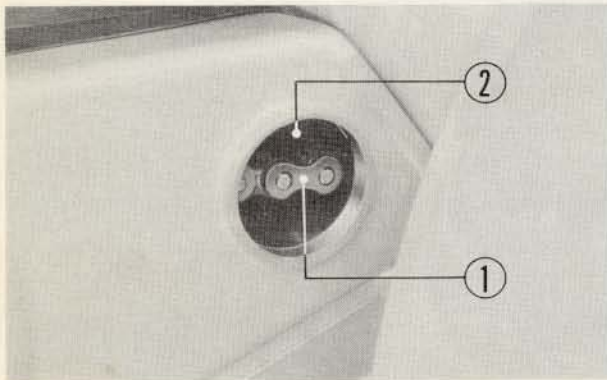

Fig. 2-16

① Drive chain    ② Inspection window

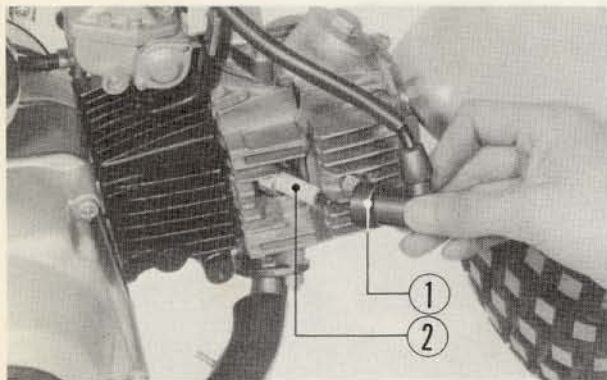

Fig. 2-17

① Spark plug cap    ② Spark plug

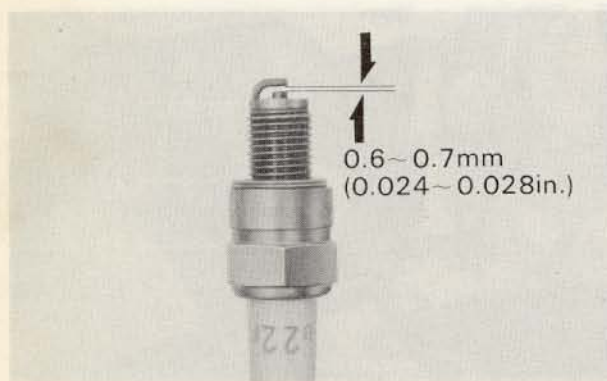

Fig. 2-18

Bending side electrode to adjust plug gap

## 9. DRIVE CHAIN

1. Loosen the tensioner lock bolt just enough to permit movement of the tensioner shaft.
2. Rotate the tensioner shaft all the way up by hand until it will no longer go; tighten the lock bolt.
3. Apply thumb pressure to the chain through the inspection window. Proper tension is obtained when the chain deflection is 10 to 20 mm (0.4-0.8 in.).

## 10. DRIVE CHAIN LUBRICATION

1. Remove the rubber cap from the drive chain inspection window.
2. Working through the window, lubricate the chain with clean engine oil.
3. After lubricating the chain, be sure to install the rubber cap.

## 11. SPARK PLUG

1. Remove the spark plug cap from the spark plug. Unscrew the plug, using spark plug wrench, and remove the plug.
2. Check the firing ends of the spark plug for deposits and electrode erosion. A fouled spark plug indicates too cold a plug, too rich a fuel mixture or otherwise excessive oil coming up into the combustion chamber.
3. A spark plug with burned electrodes and a glazed or blistered insulator nose indicates too hot a plug, too lean a fuel mixture or too early ignition timing.

### NOTE:

The use of spark plugs of incorrect size or heat range can cause serious damage to the engine.

4. Check to be sure that the gap is 0.6-0.7 mm (0.024-0.028 in.). If not, correct the gap by bending the side electrode only.

If the electrodes are pitted or roughened, clean and dress the electrodes with a file, keeping the surfaces of both center and side electrodes parallel.

5. Place a new gasket on the spark plug and screw the plug into the threaded hole in the cylinder head in two steps; first, finger tight, and then to the specified torque using a wrench. Install the spark plug cap on the spark plug.

**12. THROTTLE CABLE**

1. Examine the condition and operation of the throttle cable. The cable should not bind or impair smooth operation of the throttle lever in any steering position. Re-route the cable if it is improperly installed. Replace the cable if it has become worn or kinked.
2. Free play, measured at the tip of the throttle lever, should be maintained at **5 mm (0.2 in.)**.

The adjusting nut is located at the top of the carburetor against the end of the throttle cable sheath. Slide back the rubber sleeve to expose the throttle cable adjuster. Replace the sleeve after adjustment.

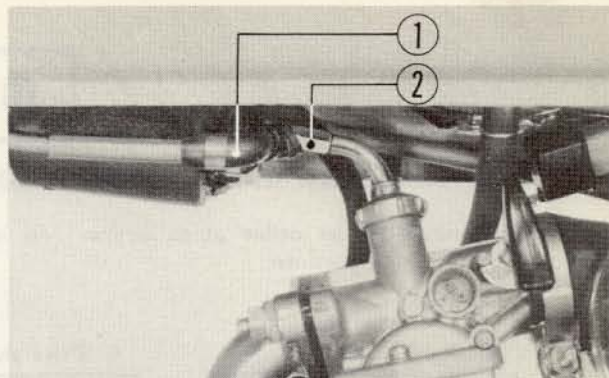

**Fig. 2-19**  
 ① Rubber sleeve    ② Throttle cable adjuster

**13. FUEL FILTER**

1. Turn the fuel valve to the "S" position.
2. Remove the two screws attaching fuel filter cover in place; remove the cover.
3. Remove the neoprene O-ring and the filter screen.
4. Wash the filter screen in solvent.
5. Reassemble by reversing the disassembly procedures.
6. Turn the fuel valve to the "ON" position, and check for leaks at the fuel filter cover.

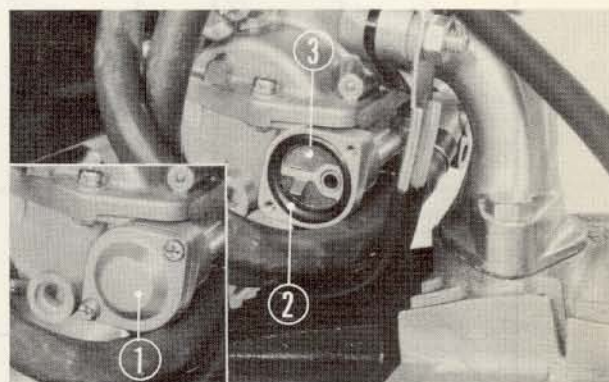

**Fig. 2-20**  
 ① Filter cover    ② O-ring    ③ Filter screen

**MEMO:**

### III. ENGINE

#### 1. ENGINE REMOVAL AND INSTALLATION

Remove the engine in the order given below. To install, reverse the removal procedure.

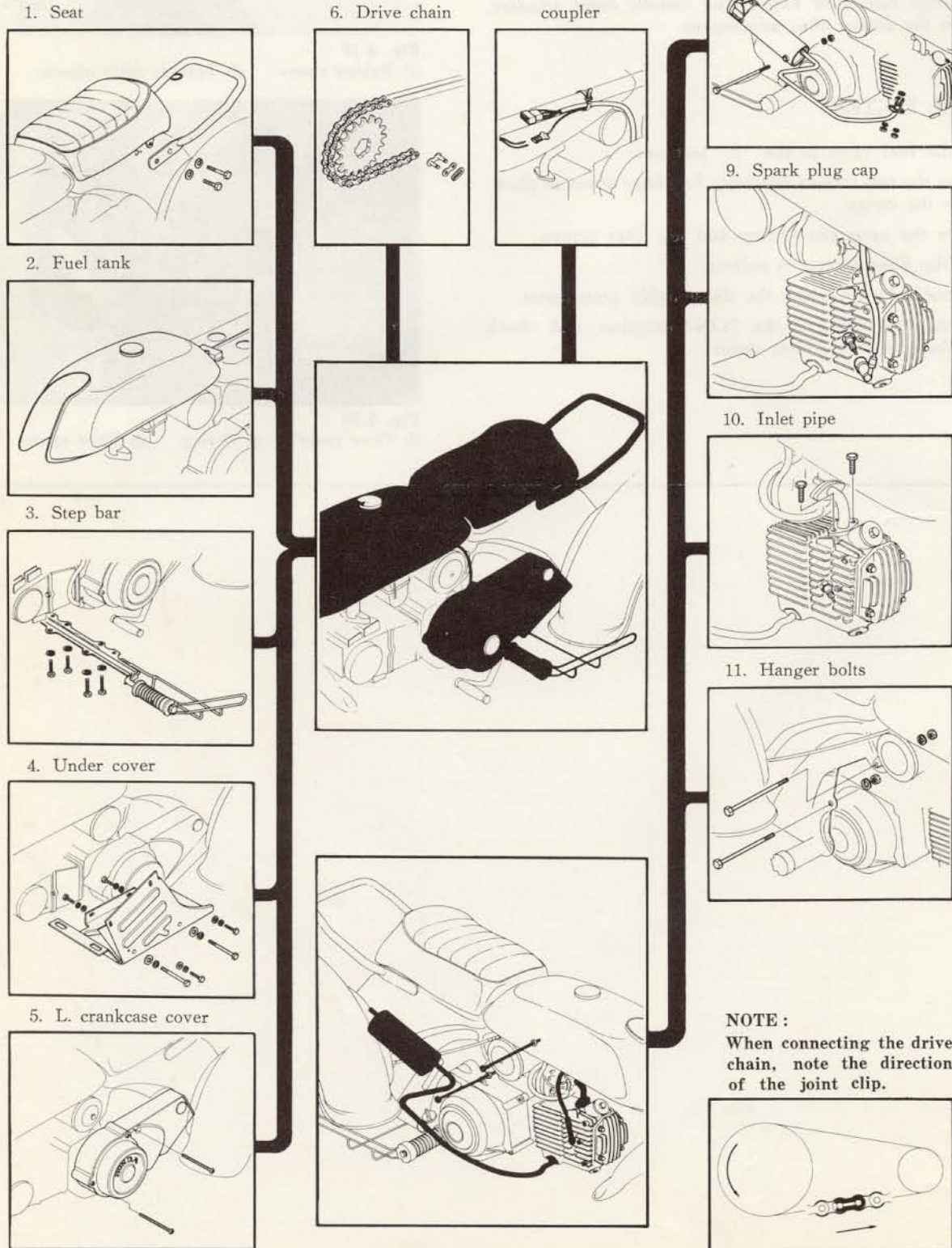

Fig. 3-1

**2. MAJOR DIFFERENCE BETWEEN ATC70 AND CT70 ENGINES**

ATC70 engines use a recoil starter in place of the kick starter.  
The carburetor is also new for ATC70 engines.

**Recoil starter**

Fig. 3-2

- ① E-ring
- ② Washer
- ③ Friction plate
- ④ Friction spring
- ⑤ Set spring
- ⑥ Washer
- ⑦ Starter ratchet
- ⑧ Recoil starter pulley
- ⑨ Starter return spring
- ⑩ Recoil starter rope
- ⑪ Recoil starter case
- ⑫ Starter knob
- ⑬ Rope stopper
- ⑭ Knob tape
- ⑮ Screw

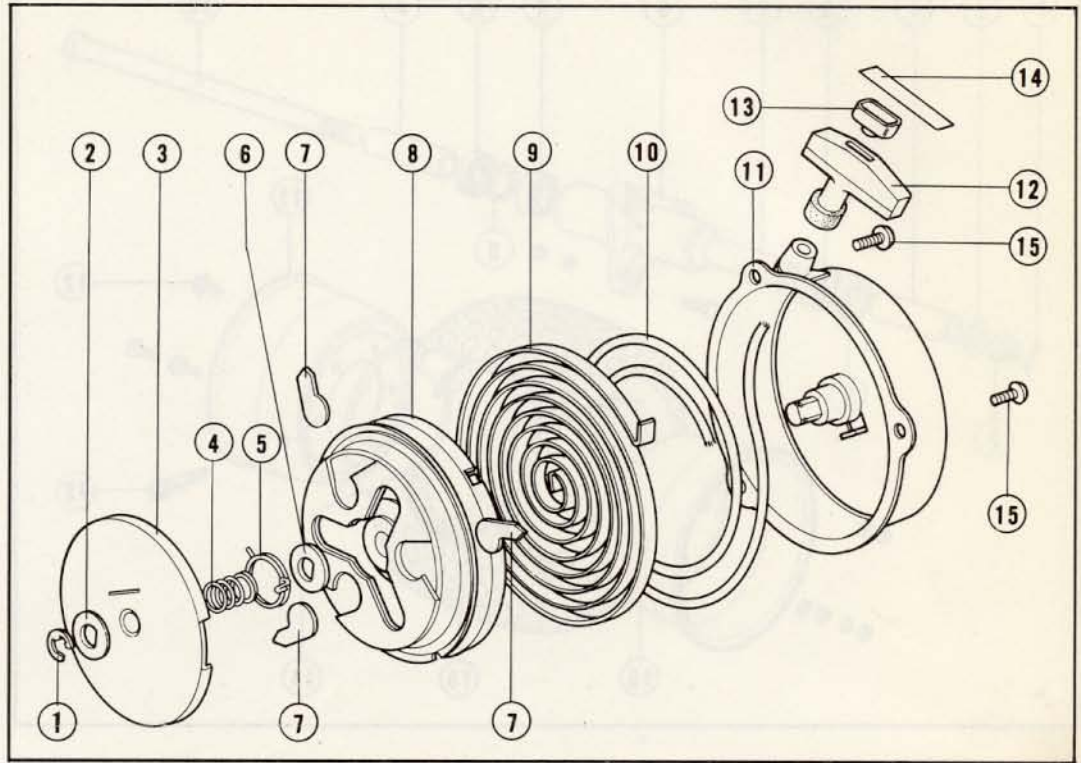

**Carburetor**

**Specifications**

Unit: mm

Main jet	# 60		AB1	0.9 dia. × 2
Air jet	# 150	Slow jet	AB2	# 35 0.9 dia. × 2
Air bleed	AB1	0.5 dia. × 4	AB3	0.9 dia. × 2
	AB2	0.5 dia. × 4	Valve seat	1.0 dia.
	AB3	0.5 dia. × 2	Pilot outlet	0.8 dia. P=5.7
	AB4	0.5 dia. × 2	Main bore	13 dia.
Needle jet	2.6 dia. × 3.8 dia.	Setting mark		695A
Air screw opening	1 1/8 ± 1/8	Fuel level		20
Cutaway	# 2.5 (width × depth) 2.0 × 0.2	Needle jet holder		5.0 dia.

## IV. FRAME

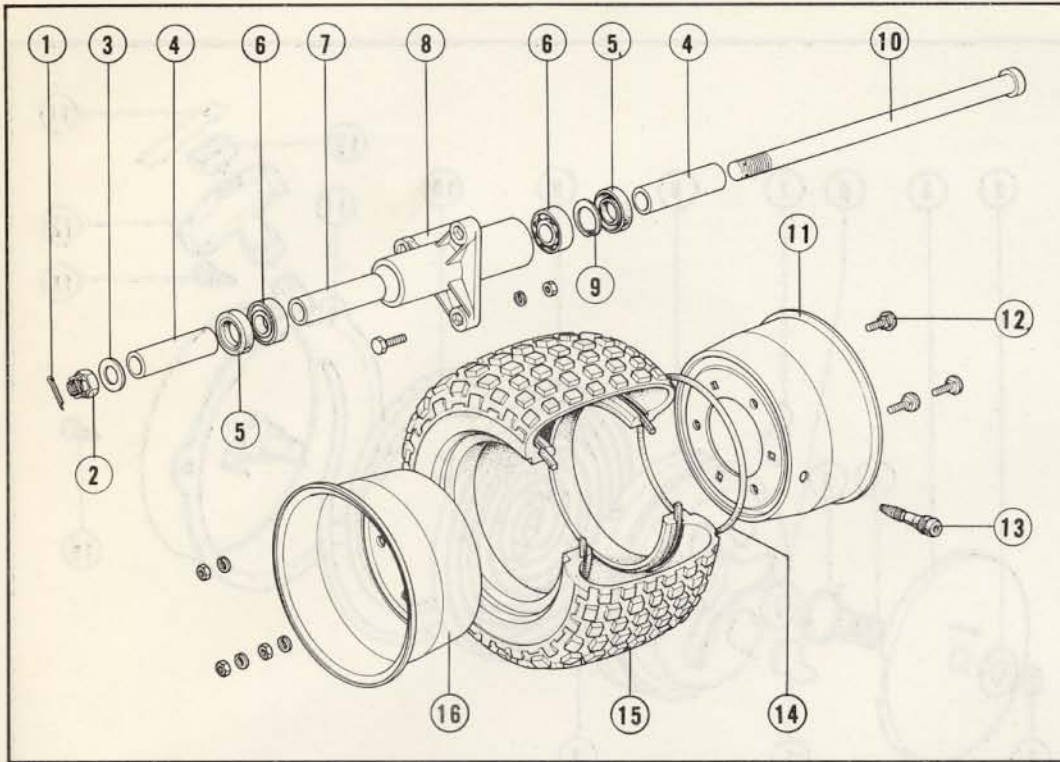

Fig. 4-1

- ① Cotter pin
- ② Castle nut
- ③ Plain washer
- ④ Front collar
- ⑤ Oil seal
- ⑥ Radial ball bearing
- ⑦ Front center collar
- ⑧ Front wheel hub
- ⑨ Snap ring
- ⑩ Front wheel axle
- ⑪ Outer rim
- ⑫ Wheel bolt
- ⑬ Rim valve
- ⑭ Wheel O-ring
- ⑮ Wheel tire (16×8.0-7)
- ⑯ Inner rim

## 1. FRONT WHEEL

## Disassembly

1. Raise the front wheel off the ground and position a suitable stand under the engine.
2. Remove the cotter pin from the castle nut and loosen off the nut from the front wheel axle.
3. Remove the front axle and take out the front wheel.
4. Take out the front collars from the wheel.

5. Remove the bolts securing the front wheel hub in position; take out the hub.
6. Remove the oil seals, snap ring, ball bearings and center collar from the wheel hub.

## NOTE:

Always replace the oil seal whenever removed.

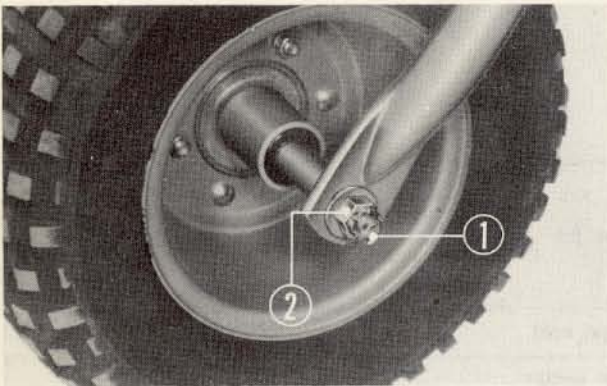

Fig. 4-2

- ① Cotter pin
- ② Castle nut



Fig. 4-3

- ① Front wheel hub

7. After complete deflation, break the tire beads loose from the inner and outer rim flanges by means of a tire tool as shown.

**NOTE:**

Do not use tire irons to force the beads away from the rim flanges; this could damage the rim seals on the beads and cause an air leak.

8. After the tire is loosened, remove the wheel bolts and then, remove the inner and outer rims from the tire.

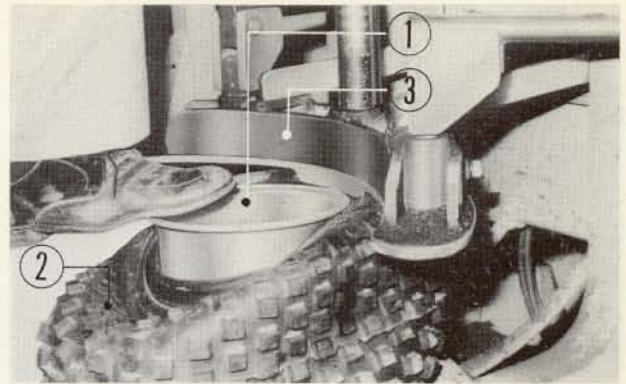
**Fig. 4-4**

① Rim    ② Tire    ③ Tire tool

**Inspection and repair**

1. Examine if the wheel axle is not bent.
2. Check the oil seal for worn or damaged sealing lip.
3. Check for signs of air leak through the rim valve.
4. Check if the rim and wheel O-ring is not deformed or damaged.
5. Check the tire pressure using a commercial tire pressure gauge. Correct tire pressure is  $0.2 \text{ kg/cm}^2$  (2.8 psi). If such a gauge is not immediately available, using a linen or steel tape, measure the length around the circumference and in the center of the tire. It should read 1,290–1,320 mm (50 to 52 in.). See Fig. 4-9.
6. Check the tire for cut, tear, wear or any other defects.
7. Puncture repair.
  - 1. First examine the tire tread carefully for nails or other puncturing objects.
  - 2. Remove the tire from the rims.
  - 3. Remove dirt and roughen the punctured area with sandpaper or wire brush. Clean the area with solvent.
  - 4. Apply rubber cement around the torn area and allow it dry. Remove the lining from the patch and center it over the injury. Press the patch against the injury, using a special roller as shown.

**Fig. 4-5**

① Sandpaper

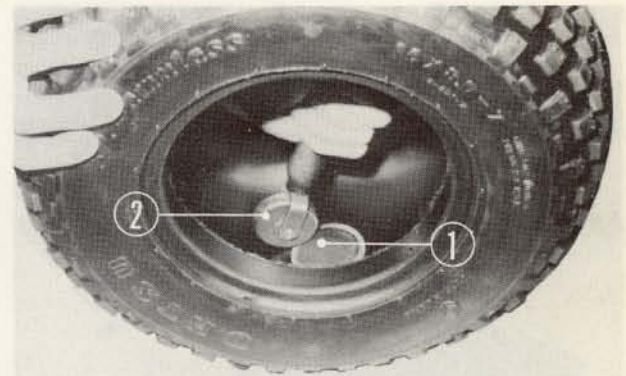
**Fig. 4-6**

① Patch    ② Roller

**NOTE:**

Apply the patch after rubber cement is dried sufficiently. Do not touch with dirty fingers after applying the rubber cement.

**Assembly****1. Tire**

- 1. Make sure that the beads are up on the bead seats and are uniformly seated all around.
- 2. Applying water on the rim flanges, bead seats and bead base makes the mounting procedure easier.

**NOTE:**

Use only clean water. Make sure that the seal surface of the rim flange is clean. If necessary, wipe it clean with a clean, lint-free cloth.

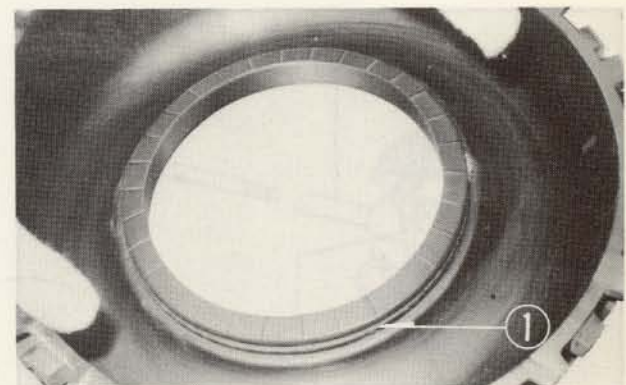
**Fig. 4-7**

① Bead



**Download the full PDF manual instantly.**

**Our customer service e-mail:**

**[aservicemanualpdf@yahoo.com](mailto:aservicemanualpdf@yahoo.com)**